



Operation, Maintenance and Service Information



DALE DISTRIBUTING LTD.
557 MINORU BLVD.
RICHMOND, B. C.

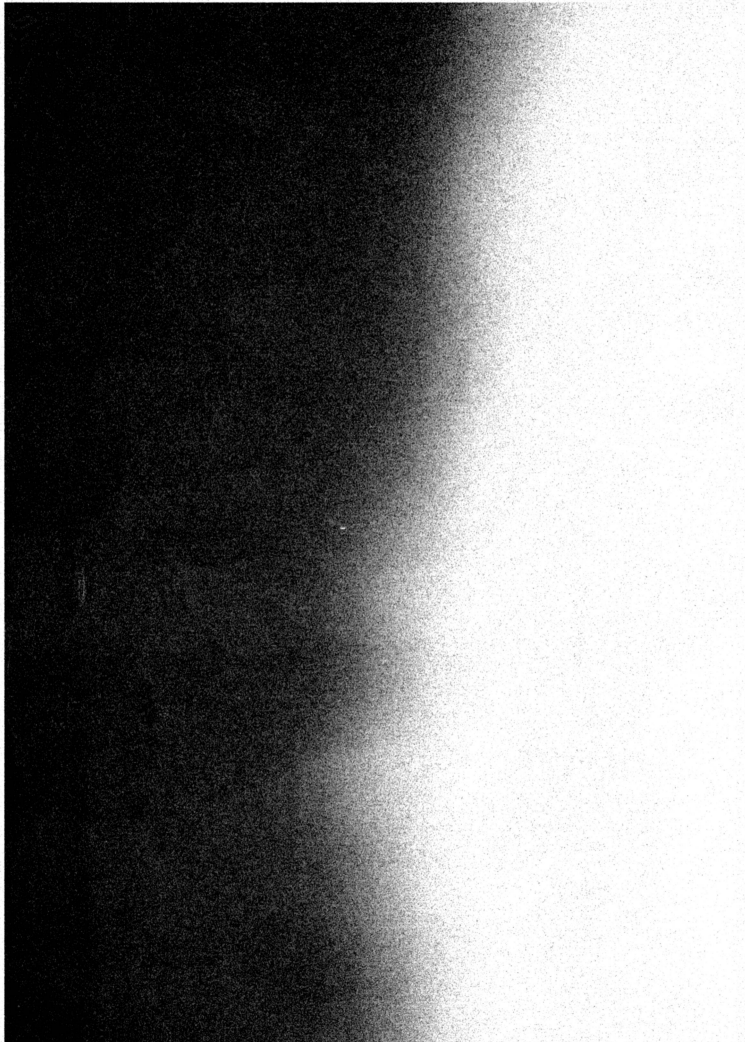

TABLE OF CONTENTS

<u>Sec.</u>	<u>Title</u>	<u>Page</u>
Section 1. General Maintenance Information		
1-1.	Introduction	1-1
1-2.	Warranty	1-1
1-3.	New Machine Setup Procedure	1-2
1-4.	Service Access	1-2
1-5.	New Machine Checkout	1-3
1-6.	TV Adjustment	1-3
1-7.	Coin Acceptor: Operation, Adjustment and Maintenance	1-5
1-8.	General Machine Maintenance	1-7
Section 2. Circuit Description		
2-1.	Play	2-1
2-2.	Circuits	2-2
	1. Sync	2-2
	2. Coin/start	2-2
	3. Planes	2-3
	4. Missiles	2-4
	5. Hit detection/score	2-4
	6. Launchers	2-5
	7. Angle/firing controls	2-5
	8. Sound	2-6
	9. Power supply	2-7
	10. Video mixing	2-7
2-3.	Setup Procedure	2-7
	1. Game time	2-7
	2. Volume control	2-7
Section 3. Customer Service Information		
3-1.	Test Equipment	3-1
3-2.	Required Equipment	3-1
3-3.	Optional Equipment	3-1
3-4.	Troubleshooting	3-2
3-5.	PCB Shipping	3-4
3-6.	Logic Type and Function List	3-4

1. GENERAL MAINTENANCE INFORMATION

1-1. INTRODUCTION

The Atari Anti-Aircraft II game consists of a cabinet, TV monitor, a printed circuit board (PCB) computer, interconnecting wiring, and various cabinet-mounted circuit components. Except for a schematic, no information about the TV monitor is presented in this manual. The TV monitor is a Motorola XM501 unit. TV circuit malfunctions can be solved using standard TV troubleshooting techniques. However, the PCB computer requires troubleshooting techniques that may be unfamiliar to the average technician. Therefore, the troubleshooting information in the manual is mainly devoted to the PCB computer and its associated cabinet circuitry.

1-2. WARRANTY

Be sure to return the enclosed warranty card immediately upon unpacking your Atari game, to ensure continued protection under the terms of the warranty.

This game has been designed with solid-state circuitry to be as maintenance-free as possible. However, as with all mechanical or electrical devices, there may be minor problems. If the PCB fails within the 90-day* warranty period, contact the distributor from whom the game was originally purchased for replacement or repair instructions. Any PCB repairs attempted by anyone other than authorized Atari Service Center personnel will void the warranty. If the PCB fails after the warranty period has expired, it will be repaired for a nominal parts and labor charge.

Atari, Inc. warrants the TV monitor for a period of 30 days commencing the day of shipment from the Atari factory. If the monitor fails within that period, immediately contact the distributor from whom the game was originally purchased for repair or replacement instructions. Any TV repairs (other than replacement of fuses or adjustments) attempted during the warranty period by anyone other than authorized Atari Service Center personnel will void the warranty.

*from date of shipment from the factory

If the TV monitor fails after the warranty period has expired, it may be returned to the distributor where it will be repaired for a nominal parts and labor charge, or it may be taken to any competent TV repair shop.

1-3. NEW MACHINE SETUP PROCEDURE

Before turning this machine on, inspect it carefully for any damage that may have occurred during shipment. Inspect both interior and exterior of the machine for any obvious damage to the cabinet or internal components. Check for cracked or broken cabinet parts, assemblies pulling loose, broken or disconnected wires, or foreign objects shorting electrical connections. After the machine has been plugged in and turned on, perform the checkout procedure.

1-4. SERVICE ACCESS

All servicing is performed at the rear of the machine through the rear door that provides access to all components, sub-assemblies, and adjustments except for the coin box. The coin door is located on the front of the machine underneath the control panel. To remove the coins, unlock the metal coin door with one of the two keys provided and open. This exposes the coin box.

To reach the interior of the machine, unlock and remove the rear door. Please note that an interlock switch is provided for this door so that the machine is completely turned off whenever this door is opened. These switches protect the operator from accidental shock and thus must ALWAYS be kept in perfect working order. If the machine is adjusted or tested with the rear door open, the interlock switch must be placed in the closed (or "on" position) by pulling out the white actuator shafts.

WARNING: The covered black terminal block carries full line voltage whenever the line plug is connected to a power outlet. This cover should be removed only with the line plug disconnected. Do not leave off the cover once it has been removed.

1-5. NEW MACHINE CHECKOUT

As each new machine leaves the factory, every component and subassembly is carefully checked for proper operation. However, since parts may have been damaged or adjustments changed during shipping, the following checkout procedure must be repeated prior to placing the machine on location:

1. Carefully inspect the interior of the machine to see that all solder joints, slip-on connectors and plug-in type connectors are firmly seated. Pay particular attention to the PCB edge connector, the fuses and any connectors to the potentiometers. Also check the connections to the coin switch, the TV monitor, the interlock switches and all the other Molex-type connectors.
2. Plug the machine in, and pull out the white actuator shafts of the interlock switches if the rear door is open. Inspect the cathode ray tube (CRT) image for a steady and sharp picture that exhibits the proper levels of brightness and contrast.
3. Insert several old and new coins into the coin acceptor. No genuine coin should be rejected and each coin insertion should advance the coin counter one digit. Depress the coin rejector button to make sure the linkage is operating smoothly.
4. Coin insertion should start the game. Check for proper game sequence, making sure that all aspects of the game are functioning correctly.
5. The door locks should turn to the locked and unlocked positions smoothly and the doors should open and close without binding.
6. The interlock switches must turn off the entire machine when the rear door is opened.

1-6. TV ADJUSTMENT

Monitor circuitry includes four stages of video amplification -- a two-stage audio amplifier, sync and deflection circuits, and a regulated power supply. An additional 5-volt supply is included to power the external logic system.

The adjustment of the TV monitor functions like that of a normal TV set. The only exception is that the TV's audio portion is not used. The volume control is located on the PCB. The CRT image is adjusted through the rear door.

1. Brightness: Adjust the brightness, then the contrast. Adjust so that the CRT background is as dark as possible.
2. Contrast: Adjust so that images displayed on the CRT are as bright and clear as possible without being blurred or smeared.
3. Vertical hold: Adjust the vertical hold only if the picture is rolling up or down the screen. Adjust for a centered picture by turning the control to the middle of the stable range.
4. Horizontal hold: If the picture is slightly off-center horizontally, if the images appear warped, or if the picture is broken into a series of diagonal lines, adjust the horizontal hold same as vertical hold.
5. Yoke: The yoke should never need adjustment unless the controls have been tampered with or the machine damaged. If yoke adjustment is necessary, adjust both yoke rings simultaneously for optimum centering of the image on the CRT. This adjustment is best handled by a qualified service person.
6. Five-volt supply: This is located on the power/audio PCB which is on the left side of the monitor behind the power transformer. There is a 1000-ohm trimpot to adjust the supply voltage. This measurement should be made on the logic PCB to allow for a voltage drop between monitor and PCB.
7. Regulator adjustment: Connect monitor to AC line supply. Adjust horizontal and vertical controls until display is synced. Connect a precision voltmeter to any of the 73-volt test points and adjust regulator control R74 on PCB for an output of 73 volts. CAUTION: Do not run the regulator control through its range or you may damage the monitor. Only a slight turn is necessary for proper adjustment. Both the 5-volt and 73-volt adjustments have been made at the factory and under normal conditions should not need readjustment.
8. AC voltage switch: Set this switch to the 115V position ("115" visible on the switch) if the machine is connected to a 115-volt source. Set it to the 230V position ("230" visible on the switch) if the machine is connected to a 230-volt source. The TV monitor will not function if this switch is misadjusted. NOTE: If the monitor of a 230-volt machine is set to 115 volts, it will blow the machine line-fuse repeatedly.

9. TV monitor fuse: One 6/10-amp, 250-volt fast-blow fuse protects the TV from electrical overload (for 155-volt operation, the TV fuse must be 1-amp fast-blow). Replace blown fuses ONLY with those which have the above rating. This fuse is located on the electronics mounting board inside the rear door. The fuse farthest from the door is the TV fuse, and the fuse nearest the door is the PCB fuse. The PCB fuse should be replaced ONLY with a one-amp, slow-blow, 250-volt fuse.

10. Monitor PCB removal:

(a) Power/audio PCB: Locate board on the left side of the monitor behind the power transformer. To remove, pull board up. To replace board, locate the slot between pins 3 and 4, and hold this side on your left; then insert board into the connector.

(b) Monitor PCB: To remove, use a screwdriver or similar object and slowly pry up off of the chassis until it clears the pins. Next, unplug the socket from the yoke and slide board out. To replace this board, follow the above steps in reverse order.

The monitor can be removed through the cabinet's rear access door. This door also provides access to the logic PCB, transformer assembly, and main harness connectors.

CAUTION: Any work performed on monitor chassis should be done only by qualified service personnel who are familiar with servicing procedures and precautions.

1-7. Q-530 COIN ACCEPTOR: OPERATION, ADJUSTMENT AND MAINTENANCE

All coin acceptors leave the factory adjusted for maximum performance. If, however, more critical adjustments are desired, or if the unit has been completely disassembled for service, the following adjustment procedure is suggested. If the coin acceptor has been removed from the machine, place it in a vertical position on a level surface. If the acceptor is still mounted on the coin door, place the coin door in a vertical position on a level surface. See exploded coin acceptor and mechanism drawings on page 1-8.

1. Kicker and separator

(a) Set the acceptor with the back of the unit facing you in the test position.

(b) Loosen the screws holding the kicker (1) and the separator (3) and move both the kicker (2) and the separator (4) as far to the right as they will go. Tighten the screws.

- (c) Insert several test coins (both old and new) and note that some are returned by striking the separator.
- (d) Loosen the separator screw and move the separator a slight amount to the left. Tighten the screw.
- (e) Insert the test coins again and, if some of them are still returned, repeat step (d) until all the coins are accepted.
- (f) Loosen the kicker screw and move the locker as far to the left as it will go. Tighten the screw.
- (g) Insert the test coins and note that some are returned.
- (h) Loosen the kicker screw and move the kicker a slight amount to the right. Tighten the screw.
- (i) Insert the coins again and, if some are still returned, repeat step (h) until all the coins are accepted.
- (j) Be sure that both screws are tight after the adjustments have been made.

2. Magnet gate

- (a) Set the acceptor with the front of the unit facing you in the test position.
- (b) Turn the magnet gate adjusting screw (2) out or counterclockwise until none of the coins will fit through.
- (c) With a coin resting in the acceptor, turn the adjuster in or clockwise until the coin barely passes through the magnet gate.
- (d) Test this adjustment using several other coins, both old and new, and if any of them fail to pass the magnet gate, repeat step (c) until all the coins are accepted.
- (e) Fix the magnet gate in this position with a drop of glue or LoctiteTM, if necessary.

3. Acceptor maintenance

Depending on the environment in which the acceptor is used, periodic preventive maintenance should be performed. The mainplate (5) may be cleaned with any household cleaner. Thorough rinsing and drying are necessary to remove deposits and/or film. Remove all metal particles from the magnet by guiding the point of a screwdriver or similar tool along the edges of the magnet. You will notice that the particles will cling to the point of the tool. Remove the transfer cradle (9)

and the undersize lever (10) and clean the bushings and the pivot pins. A pipe cleaner is an effective cleaning tool. Apply powdered graphite or pencil lead to the pivot pins and bushings and reassemble. Spray the entire unit lightly with WD-40[®], a silicone lubricant.

1-8. GENERAL MACHINE MAINTENANCE

Due to its solid-state circuitry, your machine will require very little maintenance other than periodic cleaning, lubrication and TV monitor adjustment. The cabinet and plexiglass screen may be cleaned with any non-abrasive household cleaner. The coin acceptor and the rejector linkage should be sprayed lightly once every three months with WD-40[®] or similar silicone lubricant. The potentiometer shafts must never be lubricated in any way. The TV monitor is adjusted only when the CRT picture is distorted, or if the contrast or brightness appear to be out of adjustment.

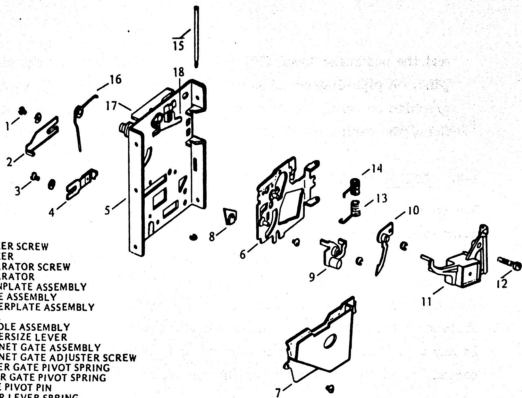

- 1 KICKER SCREW
- 2 KICKER
- 3 SEPARATOR SCREW
- 4 SEPARATOR
- 5 MAINPLATE ASSEMBLY
- 6 GATE ASSEMBLY
- 7 COVERPLATE ASSEMBLY
- 8 RAIL
- 9 CRADLE ASSEMBLY
- 10 UNDERSIZE LEVER
- 11 MAGNET GATE ASSEMBLY
- 12 MAGNET GATE ADJUSTER SCREW
- 13 LOWER GATE PIVOT SPRING
- 14 UPPER GATE PIVOT SPRING
- 15 GATE PIVOT PIN
- 16 WIPER LEVER SPRING
- 17 WIPER LEVER
- 18 WIPER

COIN ACCEPTOR - EXPLODED

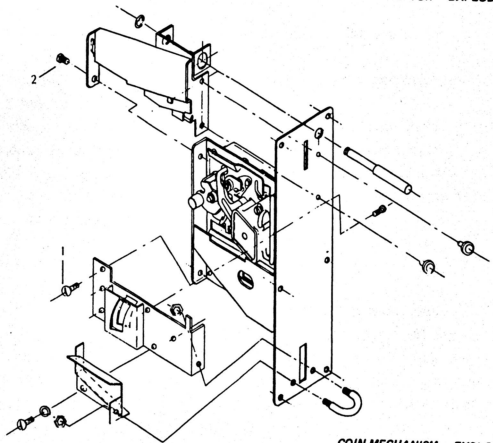

COIN MECHANISM - EXPLODED

2. CIRCUIT DESCRIPTION

2-1. PLAY

The picture below shows the normal game:

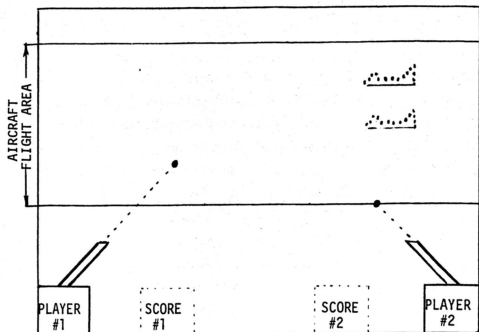

Attract: In the attract mode, the guns are locked in the center-aimed position, and are continuously firing. The aircraft fly over the guns either singly or in pairs, from the right or the left within the aircraft flight area. If an aircraft should be hit by a shell directly or by an exploding shell, it will disappear. During the attract mode, the score is disabled, as are the sound and player controls.

Play mode: Anti-Aircraft II is a two-player game that has an operator-selected option of one or two games for a quarter. The game incorporates a coin mechanism and a start button. Each player (#1 on the left and #2 on the right) has an anti-aircraft gun that positions itself in any of three positions and then fires when the proper control button is pushed. The object of the game is to shoot down more aircraft than your opponent does in the time allotted.

2-2. CIRCUITS

1. Sync

The sync circuit located at C- and D-8,7,6,5 on page 1 of the schematic is a semi-synchronous sync circuit. Its standard crystal is 14.318 MHz. The bits clock through 128H are fully synchronous; the rest of the bits are asynchronous. H sync is set by HRESET after 457H counts is 32H long. The vertical sync divide-by-260 section clocked by HRESET has a VSYNC of 8V.

2. Coin/start

The coin/start circuitry is located at C- and D-1,2,3,4 of schematic page 1 and includes devices F9, F8, E9, the electronic latch located at D-2, page 1, E8, D8, and D9. When the coin switch or coin mechanism external to the PCB is activated, a square wave pulse is proportional in length to the amount of time the coin used to activate the mechanism. The square wave pulse is present at the R-S flip flop, the latter being comprised of two inverters, F9 pin 4. This pulse is fed into the discriminator made up of two D-type flip flops (F8). This circuit determines whether or not the pulse was long enough to be a genuine coin pulse or just a switch bounce that can be induced by pounding on or near the coin mechanism. If the pulse is long enough, it is passed along and sets the electronic latch. At this point, F9-8 goes low enabling the credit light and F9-10 goes high (Q goes high) which releases the D-type flip flop D8-1, the timer D9, and the attract flip flop D8-10. Now when the start switch is depressed by a player, START (D8-5) goes high, ATTRACT (D8-9) goes low, and the timer is set. Depending on the PLAY TIME pot (1 meg, R36), the game will last between 30 seconds and three minutes, and at the control's center position will last approximately 90 seconds. At the end of the timing sequence, D9-5 will go low, transmitting a rising edge to D8-11, which clocks ATTRACT high. If the one-play/two-play switch (located D13, page 1) is in the one-play position when ATTRACT goes high, E9-8 will go low, dropping the electronic latch out and inhibiting the start circuitry. If, however, the switch is in the two-play position, ATTRACT will have to go high once more (at the end of the next game) in order to drop out the latch. Thus the start circuitry will not be inhibited and a push on the start switch will start game #2.

3. Planes

The plane motion circuitry and exact shape-generating systems are located near A- and B-3,4,5,6,7,8 of schematic page two.

The normal horizontal-motion circuit is comprised of counters H1 and F1 and flip flop F2 at the end of the counters. The horizontal speed and direction are determined by the speed code presented at pins 4,5, and 6 of counter H1. The code presented at these pins will make the count chain either two counts longer or shorter than the horizontal sync chain, meaning the horizontal window will move either two counts per frame to the right or to the left respectively. The direction then is determined by DIR. SEL (F2) being clocked by a random clock during plane reset, and the speed is fixed at two counts per frame. The horizontal window is 16 counts wide and is determined by AND gate H2-1 and -2; the horizontal window is present at H2-3.

The vertical motion circuit is unusual because it does not produce actual movement, but rather windows 8V wide. It produces two windows 8V wide at D3-6 displaced by 8V. These windows can be anywhere between 64V and $64 + 128 = 192V$, dictated by J2, an exclusive OR. These two windows are impressed upon D2-3 and D2-11 and if the other inputs to the respective gates are satisfied, a vertical window will be at D2-6 and another window displaced by 8V will be at D2-8. Each window will be 8V wide. The reasons for the other inputs not being satisfied would be if flip flop D1-6 came up high due to random clocking during plane reset, or if either plane were hit. Such a hit would cause a HIT DETECT pulse at C2-9 and C2-12 at the same time there is a high at C2-10 or C2-13 (depending on which window area the plane was hit in). In addition, this hit would cause a reset of the flip flop that controls that plane window.

The vertical and horizontal motion circuits are summed at H2-10 and -9 to produce one or two windows 8V high and 16H long at H2-8, called PLANE EN. The actual shape of the plane is contained in ROM K1 which is a programmed 82S23 PROM. The picture is brought out of the ROM one H line at a time (seen as a vertical line 1H wide and 8V tall on the screen), from either the left or right, depending on direction of plane, and therefore level with DIR. SELECT. This one line brought to the outputs of the ROM is strobed from top to bottom by the 9312 (L1). The PLANE is thus brought

out one H line at a time serially at L1-15 in correspondence with the PLANE EN window(s).

4. Missiles

The right and left missile circuits are exactly the same in construction; for the sake of simplicity we examine the right missile circuit located around B-1,2,3,4 of schematic page 1.

These two missile circuits are standard motion circuits. The horizontal motion count chain is made up of counters M8, M7, and F7 with some external gating. The NAND gate N8-3 keeps the circuit at reset until the right gun is fired or until N8-1 goes low while N8-2 is low (when the CRT is scanning the missile base). The speed of the missile is determined by the speed code present at counter M8, pins 4, 5, and 6. This speed code is in turn determined by RA and RB as shown by the external gating. The level of RA and RB is determined by the launcher's position at firing time as shown by the table at A-7 and -8 on schematic page 2.

In a similar fashion, the vertical-motion counting chain is made up of L7, L8 and external gating. The vertical speed code presented at L7-3, -4, and -5 is also dependent upon the position of the launcher at firing time and thus RA and RB. The circuit comprised of K7, H7, J2, L6, and H6 is used to display an exploding shell at the proper time.

5. Hit detection/score

This circuit is located on schematic page 2 and covers most of the page's upper half; the circuit starts in the C-7 and C-6 area and proceeds to the right and up. The two 9602s B1 control the explosion sequence. As shown by the gating directly before them, the right missile window comes in contact with the V plane window, A2-1 and -2 go high and thus H2-3 goes high, triggering 9602 B1-4 which initiates the explosion sequence. In a like manner, if the left missile window comes in contact with V plane window, the explosion sequence will be initiated. These are not necessarily aircraft hits but rather hits on the lowest plane window or closest to the guns. Such a hit will cause the shell to explode in the path of the lower aircraft.

If the aircraft is hit directly by a shell or flies into an exploding shell, it will be counted as a hit for the player who fired the shell. The hits are produced by the outputs of B2-8 and B2-11; the latter will go low if

the respective missile comes in contact with the plane window. This low produces a clock pulse at the appropriate score-counting chain, C4-14 or B4-14 (left score or right score respectively). These scores are multiplexed by the two 74153s, A4 and A5, and are brought into the 7448 BCD-to-seven-segment decoder A6 at the proper times for display on the screen. The outputs of the 7448 (A6) are fed into B6 and A7 that provide the actual shape of the individual seven-segment display. Part of the gating below the two 74153s, A4 and A5, is used to make the missile bases as shown by the composite output of B3-5 (score and missile bases).

6. Launchers

The launcher circuitry is located around A- and B-9,7,6,5 on page one of the schematic. The circuitry for the left and right launchers is essentially the same, so we will examine only the right launcher located near B7 and A7, including devices M5, L4, M4, and N5, and surrounding gating. Simply speaking, RA and RB were previously found to be related to the horizontal and vertical speeds of the missile and hence the angle of the missile. RA and RB are fed into the select lines of the two multiplexers M5 and L4. The inputs of the multiplexers are various H counts. When properly selected by RA and RB (depending on which control button is pushed), these H counts are transmitted via the outputs of the multiplexers and the comparator M4 (the 4-bit digital comparator 7485). At M4, these H counts are compared with V counts to produce a launcher barrel line of the appropriate angle for the motion of the missile. Note that V counts are inverted and thus reversed for the left launcher to provide an opposite angle or mirror image of the right one. These signals are then brought into a one-shot (9602) E1 for both launchers; the width of these lines is determined by the RC time constant of C25 and R39. Thus we have a thin line made into a barrel by E1.

7. Angle/firing controls

This circuit is located at B- and C-8,7,6,5 of the schematic's page one. SW1 through SW6 are the external controls used by the players to control the angle of the launchers and the firing of the missiles. The actual angle of the launcher and which launcher is being controlled are shown by the chart at C8, just above the switches. The multiplexer J9 is con-

tinuously being selected by 1H and 2H. The timing between these H counts and the outputs of J9 determines the levels of RA, Rb for the right player and LA and LB for the left player, as produced by the interconnecting flip flops K8 and K9. In turn, the outputs of J9 depend on the button pushed. If a button is not pushed, the angle of the launcher will remain the same; when a button is pushed, the angle will change, the missile will fire, and it remains at this new angle until a different button is pushed. Farther to the right on the schematic are the FIRE RIGHT and FIRE LEFT control flip flops. These flip flops are cleared when a fire button on the proper side is pushed. The complement output \bar{Q} of these flip flops disables the multiplexer J9 during the firing sequence to prevent changing the launcher angle during launch. The fire signal is clocked away; thus the multiplexer is released when the missile hits something (plane or V plane window) or when the missile goes off into blanking.

8. Sound

The sound circuit is located on page two of the schematic near B- and C-1,2,3. Q4 (2N3643) and surrounding resistors and capacitors R38, R36, S24, and C29 comprise a noise-generating circuit. Noise output should be around 100 MV. B10 is a band pass network with the second half of B10 used to amplify the desired frequency range.

The output at B10-10 is fed into B9-2. B9 is a NOR gate being used as a feedback amplifier. B9-1 is normally high and therefore the output B9-3 is normally at a low potential. When a low is placed on the cathode of D2 capacitor, C3 (1 mf) is discharged through R4 and brought to near ground potential. At this point B9-1 is low and the amplified sound of B9-2 is allowed to pass through the MOS gate. This gate can be thought of as an analog gate, since a normal NOR gate would not pass an analog signal. C3 immediately begins to charge up through R3 and the point B9-1 begins to rise in potential. The effect of B9-1 rising in potential is to diminish the amplitude of the output at B9-3 until B9-1 reaches a high enough level; at this time it causes a solid low at output of B9-3. This output is summed at the input of the LM380, A9, and is used as the distant explosion (no aircraft hit) sound. In a similar manner, the explosion (direct hit) is brought through B9-9 to B9-10 after one more stage of amplification. The control, however, is the same at B9-8 as it was at B9-1 for distant explosion.

The missile whistle is caused when the missile is fired. D9 is a free-running oscillator (555) whose output to C19 is a triangular wave with a period of 60 ms. This output is fed into the 566 (C9) pin 5. The oscillation of C9 depends on the RC time constant between R26 and C18. However, if the side of R26 labeled MISSILE WHISTLE is low, the oscillator will not function and there will be no output at C9-4. When a missile is fired and throughout its flight, MISSILE WHISTLE goes high enabling the 566 (C9). The output of this device is a triangular wave that starts out at a period of about .5 ms and extends to a period of about .9 ms at the end of the firing sequence.

9. Power supply

The power supply is a standard on-board full-wave rectifier using an LM323 voltage regulator for the 5 VDC power supply. The negative supply also uses a full-wave rectifier (D12 and D11) with a 5.6V zener across a 1000 μ f capacitor to provide -5.6V at 4 ma.

10. Video mixing

The video mixing network located at A4 and -5 on page 1 of the schematic resistively sums the different video wave forms to one common node and then passes them on to the video monitor through video cap.

2-3. SETUP PROCEDURE

1. Game time

The game time pot is located at D-9 on the PCB and is labeled "play time." Looking down the board toward the edge connector, the play time is increased by turning it clockwise. The normal game time should be between 90 and 100 seconds. This is achieved by turning the pot to its center position and timing the game. Then turn the pot in the correct direction until proper game time is achieved.

2. Volume control

The volume control pot is located at A-9 on the PCB. Looking down the board toward the edge connector, the volume is increased by turning the pot counterclockwise. Adjust volume to desired level.

The first part of the document discusses the importance of maintaining accurate records of all transactions. It emphasizes that every entry should be supported by a valid receipt or invoice. This ensures transparency and allows for easy verification of the data.

Secondly, the document highlights the need for regular audits. By conducting periodic reviews, any discrepancies or errors can be identified and corrected promptly. This proactive approach helps in maintaining the integrity of the financial data.

Furthermore, it is advised to use standardized accounting practices. This includes following established guidelines for recording and reporting financial information. Consistency in these practices is crucial for comparing data over time and across different departments.

The document also stresses the importance of data security. All financial records should be stored in a secure environment, protected from unauthorized access. Regular backups should be performed to prevent data loss in case of a system failure or disaster.

In conclusion, the document provides a comprehensive overview of the key principles for effective financial record-keeping. By adhering to these guidelines, organizations can ensure the accuracy and reliability of their financial data, which is essential for informed decision-making and long-term success.

3. CUSTOMER SERVICE INFORMATION

3-1. TEST EQUIPMENT

In order to test any Atari PCB, some items such as the logic probe are absolutely essential. Others are desirable and will make the test procedure easier but are not absolutely essential. Some of these instruments are available from the Atari Customer Service Department and are: the Kurz-Kasch 520 Logic Probe, the Atari Video Probe, and the Hewlett-Packard 10529A Logic Comparator. Other instruments that are very useful are the HP 10526T Logic Pulser and the Tektronix 465 Oscilloscope. These items are available through your local electronics supply house.

3-2. REQUIRED EQUIPMENT

The following items are essential to perform the test procedures presented in this manual:

1. Logic probe: This instrument is designed for checking the outputs of integrated circuits. The Kurz-Kasch Logic Probe, Model No. LP-520, which is available through the Atari Customer Service Department or most large electronics supply houses, is recommended. This logic probe indicates if a signal is a logic high, logic low, or changing from one state to another. Consult the operating instructions included with the probe for further details about its operation.

2. Video probe: This probe is a very simple but extremely useful device and consists of two test clips, a length of rubber-coated, test lead wire, and a 4.7K, $\frac{1}{4}$ -watt carbon resistor. Video probes may be obtained from the Atari Customer Service Department or, if necessary, they can be assembled from standard components available at all electronics supply houses.

3-3. OPTIONAL EQUIPMENT

It is possible to find 90% of the possible PCB computer malfunctions without the following items. However, if a complete set of troubleshooting equipment is desired, Atari recommends the following:

1. Hewlett-Packard 10529A Logic Comparator

This device is used to verify correct IC operation. It simply clips onto in-circuit ICs and instantly displays any logic state difference between the in-circuit test IC and the reference IC in the comparator. Logic differences for each pin of a 14 or 16 dual in-line package are indicated by a lamp on the comparator. If the logic comparator is purchased from the Atari Customer Service Department, it is shipped with 20 pre-programmed reference PCBs. If the device is purchased elsewhere, these PCBs must be specially programmed.

2. Hewlett-Packard 10526T Logic Pulser

This device is used to stimulate in-circuit ICs so that they are driven to their opposite states. This device is available from the Atari Customer Service Department or can be obtained from most large electronics supply houses.

3. Tektronix 465 Oscilloscope

This oscilloscope is used for viewing various wave forms and should be ordered from Tektronix. Consult the manufacturer's operating instructions for details on oscilloscope operation.

3-4. TROUBLESHOOTING

The first step in any troubleshooting procedure is to observe the characteristics of the malfunction. With these clues in mind, examine the areas of the machine that might cause these symptoms. For example, if there is no power, check the harness -- not the PCB. Likewise, if part of the playfield display is missing, check the PCB -- not the harness or TV.

Three major areas of the game can be isolated for troubleshooting purposes: the TV, the PCB, and the harness. The harness includes the fuses, the transformer, the interlock switches, the AC line filter, the start and coin switches, the antenna wire, the potentiometers, all plug-in type connectors, the PCB edge connector, and all the interconnecting wires.

1. Substitution: Substitution of parts is a legitimate and easy way to troubleshoot the machine. For instance, if you suspect a PCB malfunction, try substituting another known-to-be-good PCB. To check the TV monitor

by substitution, connect the malfunctioning game to a known-to-be-good monitor. Harnesses are checked by elimination. Substitute a good TV and PCB, and if the malfunction persists, the harness must be at fault.

2. Other troubleshooting tips: If you have only a TV raster* and you want to determine if the PCB or the TV is causing lack of video display, try the following test:

- (a) Disconnect the PCB edge connector;
- (b) Turn the brightness and contrast all the way up;
- (c) Touch video input to TV, pin 10 on PCB edge connector.

If your TV monitor is functioning correctly, you will see faint black bars or "hum bars" on the screen.

3. Troubleshooting by symptom:

- (a) No power: Check for correct line voltage. If correct, check fuses and interlock switches. If these are alright, check transformer primary, which should show line voltage. Then check transformer secondary (pins 3 and 21), which should be 10 VAC with respect to ground.
- (b) Game credit shuts off: Try cutting the antenna wire shorter in increments of 1-2 inches.
- (c) Game credit shuts off and/or TV picture shrinks: Check line voltage with VOM and be aware that a large motor nearby (such as an air conditioner) may drop line voltage when starting up.
- (d) No picture or raster: Check to see if TV connector is plugged in; check for line voltage at TV, and whether the latter's AC voltage switch is set to correct position. Check TV fuses and brightness control.
- (e) TV raster only: Check harness and especially the PCB edge connector. Check PCB and TV.
- (f) Picture rolls: Adjust TV vertical hold. Check or replace PCB.
- (g) Picture is wavy: Adjust TV horizontal hold. Replace transformer. Check harness, particularly grounds, 5-volt supply, and 73-volt regulator.
- (h) Picture is broken into diagonal lines: Adjust TV horizontal hold. Replace PCB.

*a TV raster is a blank but lighted TV screen with the brightness turned all the way up

- (i) Jerky plane motion: Replace appropriate potentiometer.
- (j) No game credit: Check coin mechanism and switch, and the harness. Replace PCB.
- (k) Game sequence incorrect or parts of playfield display missing, distorted or not functioning: Replace PCB.
- (l) No audio: Check volume control, speaker connections. Replace PCB.
- (m) White picture but no display: Check edge connector on logic PCB, 5-volt supply from monitor, and 12-pin Molex connector on monitor.
- (n) No firing: Check firing buttons and harness connections.

Note: If the above checks do not solve the problem, consult the appropriate theory of operation description of the logic PCB circuits.

3-5. PCB SHIPPING

Careful packing of PCBs and other parts being returned to the factory is recommended, as Atari cannot be liable for items damaged in transit. If possible, include a short statement describing the problem encountered with the game.

3-6. LOGIC TYPE AND FUNCTION

<u>TYPE</u>	<u>FUNCTION</u>
7400	quad 2-input NAND gate
7402	quad 2-input NOR gate
7404	hex inverter
74S04	hex inverter
7408	quad 2-input AND gate
7410	triple 3-input NAND gate
7413	dual NAND Schmitt trigger
7420	dual 4-input NAND gate
7425	dual 4-input NOR with strobe
7427	triple 3-input NOR gate
7430	single 8-input NAND gate
7448	BCD-to-7-segment decoder
7450	dual AND/OR gate (inverter/expander)
7474	dual-D flip flop
7483	4-bit full adder

(Logic type and function, cont.)

<u>TYPE</u>	<u>FUNCTION</u>
7486	quad exclusive OR gate
7490	decade counter
7492	divide-by-12 counter
7493	4-bit binary counter
74107	dual JK M/A flip flop
74153	dual 4-bit multiplexer
74157	quad 2-input data selector/multiplexer
74165	parallel-load 8-bit shift register
74192	synchronous decade up/down counter
74193	synchronous binary up/down counter
LM380	amplifier
NE555	timer
NE566	function generator
747	dual operational amplifier
RC4136D	quad operational amplifier
MFC6040	voltage-controlled operational amplifier
8098	hybrid
8103	hybrid
8099	hybrid
9311	one-of-sixteen decoder/demultiplexer
9312	8-input multiplexer
9314	quad latch
9316	4-bit binary counter
9321	dual one-of-four decoder
9602	dual monostable multivibrator
74186	ROM



ASSEMBLY TITLE / TOP ASSEMBLY ANTI-AIRCRAFT P/L 003026

PARTS LIST SPECIFICATION Page 1 of 2

Drawn _____
 Checked *P. J. O. M.* Mech. Eng. *J. J. O. M.*
 Proj. Eng. *J. J. O. M.* Elec. Eng. *J. J. O. M.*

REV. F

Rev.	Description	Date	Appr.	Rev.	Description	Date	Appr.
1	Prototype Rel						
A	Prod. Rel						
B	Rev Per ECN 1042	1-8-75	<i>J. J. O. M.</i>				
C	Rev Per ECN 1059	1-10-75	<i>J. J. O. M.</i>				
D	Rev per ECN 1090	1-15-75	<i>J. J. O. M.</i>				
E	Rev per ECN 1439	2-12-75	<i>J. J. O. M.</i>				
F	Rev per ECN 1461	5-15-75	<i>J. J. O. M.</i>				

Item	Part Number	Qty.	DESCRIPTION
1	A003027	1	Assy, Cabinet
2	A003046	1	Assy, Electronics Tray
3	A003048	1	Assy, Control Panel
4	A003637	1	Assy, Coin Door (Airtronics)
5	A001508	1	Illum. P.C. Board Assy.
6	A000951	1	P.C. Board Assy.
7	A003102	1	Assy, Florescent Light 18"
8	003053	1	Retainer, Upper Plex
9	001656	1	Bezel
10	003052	1	Plex Screen
11	92-006	1	T.V., Motorola (XM 501), 19"
12	71-2112	1	Lock, Mech., Barrel Cart.
13	74-3c20	4	Spacer 1.25"
14	002728	2	Panel Mtg. Bracket
15	003051	1	Retainer, Control Panel
16	000869	1	Grill, Speaker
17	48-004	1	Speaker, 5" Arkay#P50C5
18	73-77001	4	Pop Rivet
19	001141	1	Foam Pad (.75)
20	74-3608	1	Spacer, Tubular, (Non-Threaded), .50 Lg. Brass
21	82-8116B	3	Button Head Socket Cap Screw, 10-24 x 1" Lg. Black
22	72-5120	2	Screw, Machine, Hexagon Head, 10-24 x 1 1/4" Lg.
23	75-2824S	4	Screw, Mach, Phil, Rnd. Hd., #8-32 x 1.50" Lg.
24	75-048	4	Washer, Split Lock #8
25	75-918S	4	Nut, Hex, #8-32
26	75-018S	4	Washer, Flat #8
27	72-6628	4	Screw, Sht. Met., Pan Hd, Phil #6 x 1.75" Lg.
28	72-6616	1	Screw, Sht. Met., Pan Hd, Phil #6 x 1.00" Lg.
29	72-6812	6	Screw, Sht. Met., Pan Hd, Phil #8 x .75" Lg.
30	75-5520B	2	Bolt, Carriage # 1/4-20 x 1.25" Lg. Black
31	75-010S	10	Washer, Flat, #10
32	75-040	10	Washer, Split-Lock, #10
33	75-911S	8	Nut, Hex, #10-24
34	75-931	2	Nut, Wing, #10-24
35	75-5128B	6	Bolt Carriage #10-24 x 1.75" Lg. Black
36	* 70-304	1	18" Florescent Tube, F15T12
37	003054	1	Instruction Plate
38	75-015S	2	Washer, Flat, 1/4
39	75-045	2	Washer, Split Lock, 1/4
40	75-935	2	Nut, Wing 1/4-20

* 70-304 70-303.18" Fluorescent tube. F15T8 Can be used as an Alternative.



DATA

1957

PARTS LIST SPECIFICATION

Page 2 of 2

Item	Part Number	Qty.	DESCRIPTION
41	003753-01	1	CRT Decal - Right Side
42	003754-02	1	CRT Decal - Left Side
43	003903	1	Bezel Shim
44	72-6608	4	Screw, SM, Pan Head, Phil. #6 x .50 Lg.



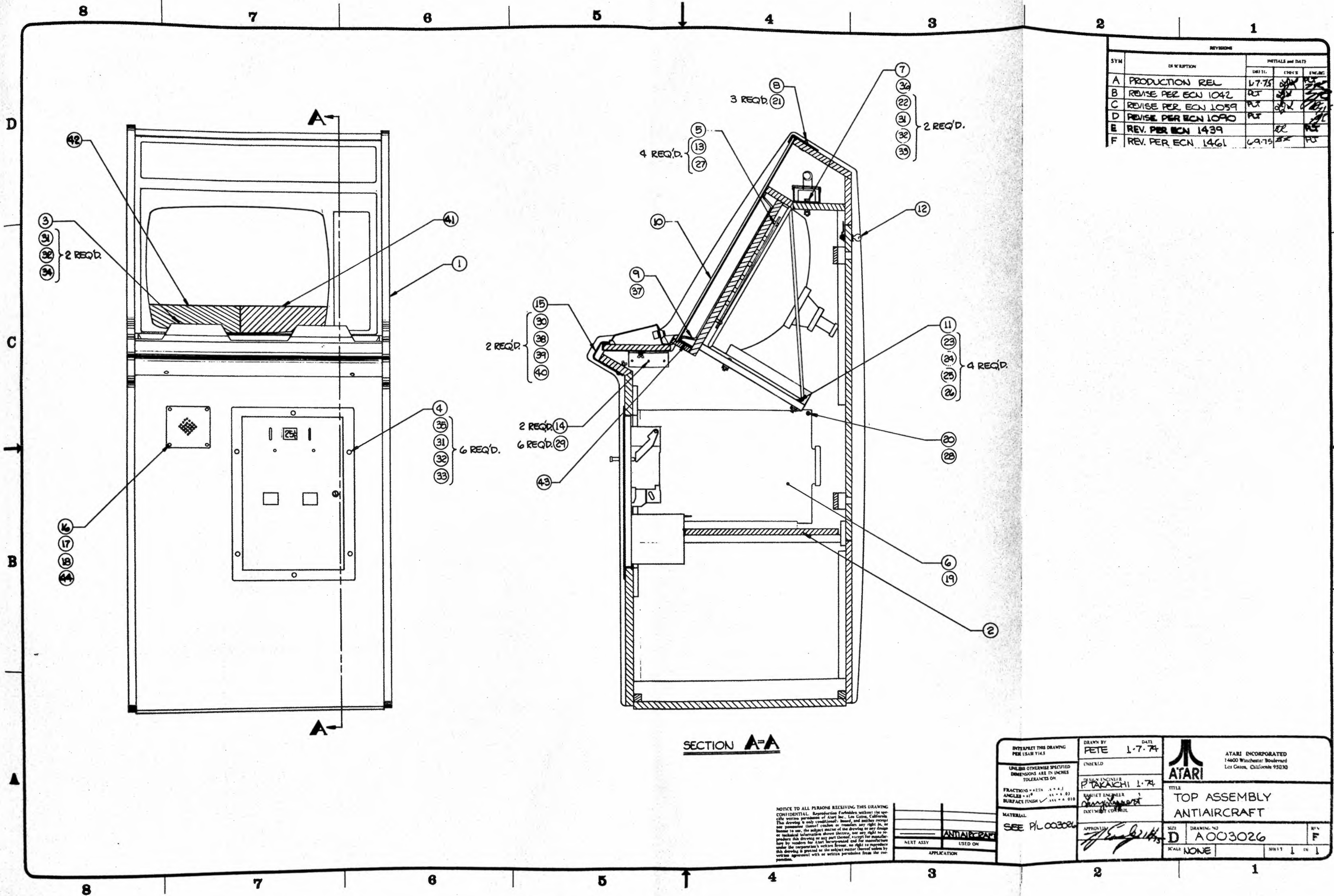

REVISIONS				
SYM	DESCRIPTION	DETAILS and DATE		
		DATE	BY	CHKD.
A	PRODUCTION REL	1-7-75	PL	PL
B	REVISE PER ECN 1042	PL	PL	PL
C	REVISE PER ECN 1059	PL	PL	PL
D	REVISE PER ECN 1090	PL	PL	PL
E	REV. PER ECN 1439	PL	PL	PL
F	REV. PER ECN 1461	1-9-75	PL	PL

SECTION A-A

NOTICE TO ALL PERSONS RECEIVING THIS DRAWING
 CONFIDENTIAL - Reproduction forbidden without the specific written permission of Atari Inc., Los Gatos, California. This drawing is only conditionally loaned, and neither drawings nor information thereon are to be distributed or used in any way without the express written permission of Atari Inc. All information contained herein is confidential and its disclosure to anyone other than those specifically named herein is strictly prohibited. Atari Inc. reserves the right to make changes in this drawing at any time without notice. No liability is assumed by Atari Inc. for any damage or loss of any kind resulting from the use of this drawing in any way without the express written permission of Atari Inc.

ANTIAIRCRAFT
NEXT ASSY USED ON
APPLICATION

INTERPRET THIS DRAWING PER ISIRI 1145	DRAWN BY PETE	DATE 1-7-74	 ATARI INCORPORATED 14600 Winchester Boulevard Los Gatos, California 95030
UNLESS OTHERWISE SPECIFIED DIMENSIONS ARE IN INCHES TOLERANCES ON	CHECKED	DESIGN ENGINEER P. TAKACHI 1-74	
FRACTIONS - 1/16, 1/8, 1/4, 1/2, 3/4, 1	SUBJECT ENGINEER C. J. JENSEN		TITLE TOP ASSEMBLY ANTIAIRCRAFT
MATERIAL SEE PL 0003026	APPROVED <i>[Signature]</i>	SIZE D	DRAWING NO. A003026
		SCALE NONE	SHEET 1 OF 1

DRAWING NUMBER
 A003026
 SHEET
 1 OF 1



ASSEMBLY TITLE / ANTI-AIRCRAFT ELECTRONICS TRAY ASSY P/L 003046

PARTS LIST SPECIFICATION

Page 1 of 1

Drawn
 Checked *S. L. Welch* Mech. Eng. *P. J. ...*
 Proj. Eng. *Larry Lappert* Elec. Eng. *T. ...* REV. C

Rev.	Description	Date	Apprv.	Rev.	Description	Date	Apprv.
1	Prototype Release						
A	Production Release						
B	Rev per ECN 1043	1-10-74					
C	Rev per ECN 1159	2/26/75					

Item	Part Number	Qty.	DESCRIPTION
1	003047	1	Tray, Electronics
2	A003093	1	Harness
3	001551	1	Transformer
4	79-3201	1	Fuse Holder
5	46-20110	1	Fuse
6	90-3001	1	Filter, Power Line
7	68-001	1	A.C. Power Interlock Switch
8	000268	1	Bracket, Switch mtg.
9	54-401	1	Power Cord, 8'
10	A001920	1	Harness, Voltage Selection
11	*A001921-01	1	Shorting Block, 95V
12	*A001921-02	1	Shorting Block, 110V
13	*A001921-03	1	Shorting Block, 220V H
14	78-25002	4	Screw Down, Tie Wrap
15	000622	1	Cover, Transformer
16	72-6608	22	Screw, SM, Pan Hd, Phil #6x1/2 lg.
17	002808-03	1	Int. Switch Harness
18	*A001921-04	1	Shorting Block, 220V L

* Install shorting block per voltage required

REVISIONS				
SYM	DESCRIPTION	DATE	CHKD	ENGR
A	PRODUCTION REL.	1-13-75	ES	PC
B	REV PER ECN 1043	1-14-75	ES	PC
C	REV PER ECN 1159	2-27-75	ES	PC

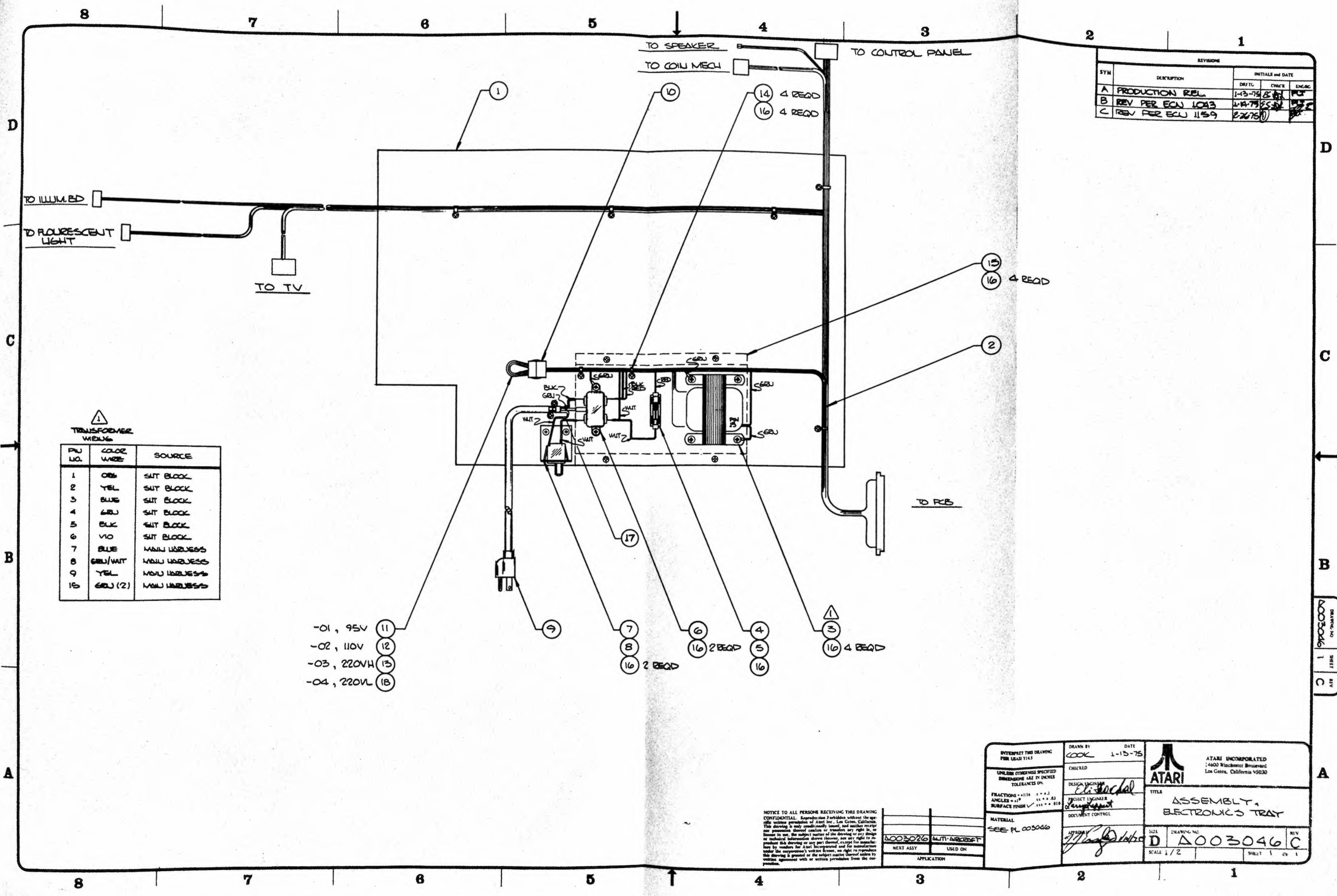

TRANSFORMER WIRING

PU NO.	COLOR WIRE	SOURCE
1	ORG	SUT BLOCK
2	YEL	SUT BLOCK
3	BLU	SUT BLOCK
4	GRN	SUT BLOCK
5	BLK	SUT BLOCK
6	VIO	SUT BLOCK
7	BLU	MAIN WIRELESS
8	GRN/WHT	MAIN WIRELESS
9	YEL	MAIN WIRELESS
15	GRN (2)	MAIN WIRELESS

- 01, 95V (11)
- 02, 110V (12)
- 03, 220VH (13)
- 04, 220V (18)
- (9)
- (7)
- (8)
- (16) 2 REQD
- (6)
- (16) 2 REQD
- (4)
- (5)
- (16) 4 REQD
- (3)
- (16) 4 REQD

NOTICE TO ALL PERSONS RECEIVING THIS DRAWING
 CONFIDENTIAL. Reproduction is prohibited without the written permission of Atari Inc., Los Gatos, California. This drawing is only conditionally issued, and neither conveys nor guarantees the nature or character of any design or mechanical information shown hereon, nor any right to reproduce this drawing or any part thereof, except the manufacturer by license for Atari Incorporated and the manufacturer under the company's written license, no right to reproduce this drawing is granted or the subject matter derived hereby by written agreement with or written permission from the corporation.

INTERPRET THIS DRAWING FOR LEAD 1144	DRWN BY: COOL	DATE: 1-13-75	 ATARI INCORPORATED 4403 Winchester Boulevard Los Gatos, California 95030		
UNLESS OTHERWISE SPECIFIED DIMENSIONS ARE IN INCHES TOLERANCES ARE:	CHECKED:	DESIGN ENGINEER: <i>Ed Stuchal</i>		TITLE: ASSEMBLY, ELECTRONICS TRAY	
FRACTIONS - 1/16 1/8 1/4 1/2 3/4 1	PROJECT ENGINEER: <i>Ed Stuchal</i>	DOCUMENT CONTROL:	SIZE: D		
ANGLES - 15° 30° 45° 60° 90° 120° 150° 180°	MATERIAL: SEE PL 003046	SCALE: 1/2	DRAWING NO: Δ003046		
APPLICATION: <table border="1"> <tr> <td>NEXT ASSY</td> <td>USED ON</td> </tr> </table>	NEXT ASSY	USED ON	REV: C SHEET: 1 of 1		
NEXT ASSY	USED ON				

Δ003046
 1
 C

REVISIONS		
SYM	DESCRIPTION	INITIALS and DATE
Δ	PROD DEL	DRFTG CHW 4/75
B	Rev Per ECR# 1473	6/9/75 ES

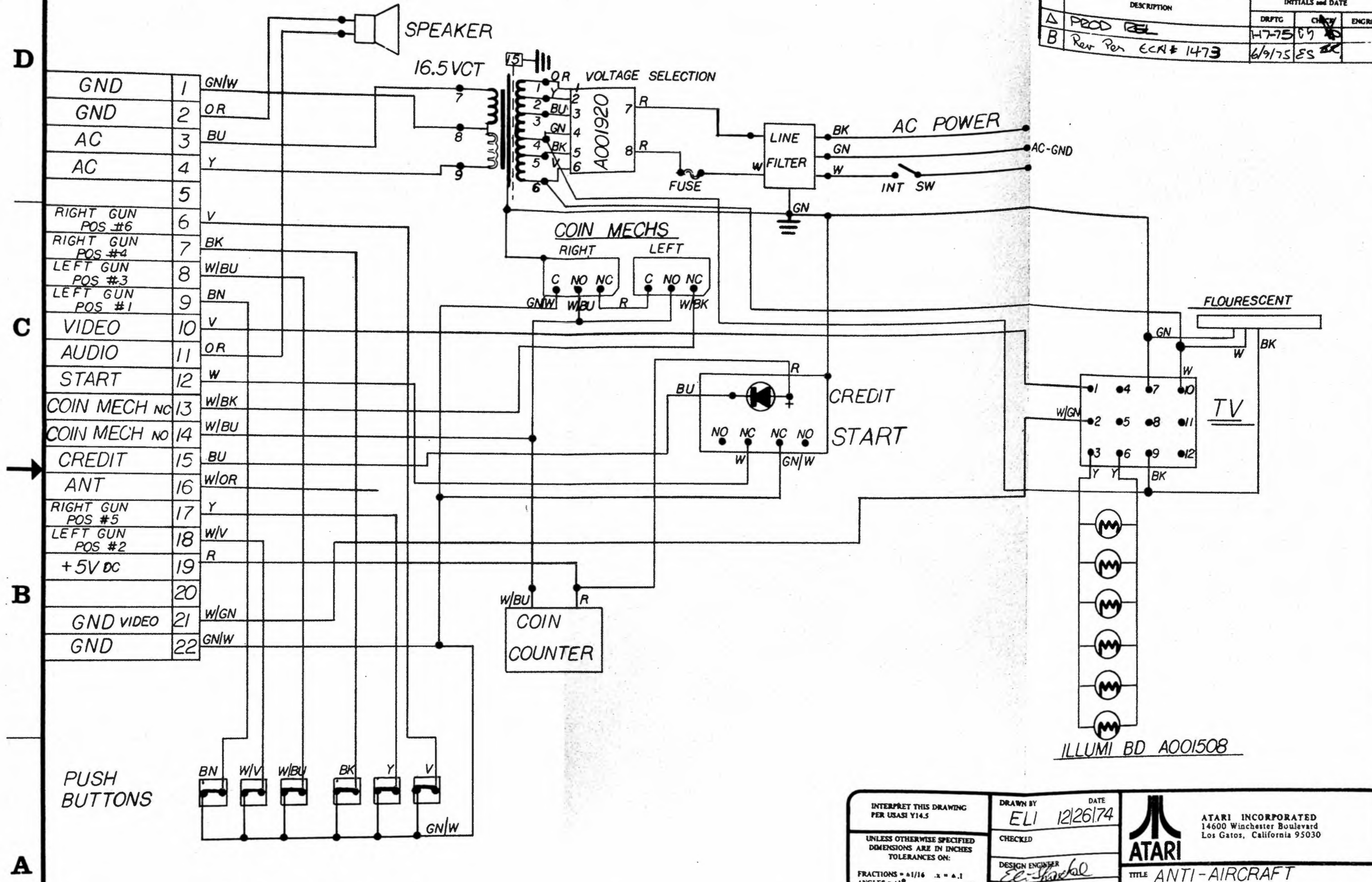

D
C
B
A

D
C
B
A

GND	1	GN/W
GND	2	OR
AC	3	BU
AC	4	Y
	5	
RIGHT GUN POS #6	6	V
RIGHT GUN POS #4	7	BK
LEFT GUN POS #3	8	W/BU
LEFT GUN POS #1	9	BN
VIDEO	10	V
AUDIO	11	OR
START	12	W
COIN MECH NO 13	13	W/BK
COIN MECH NO 14	14	W/BU
CREDIT	15	BU
ANT	16	W/OR
RIGHT GUN POS #5	17	Y
LEFT GUN POS #2	18	W/V
+5V DC	19	R
	20	
GND VIDEO	21	W/GN
GND	22	GN/W

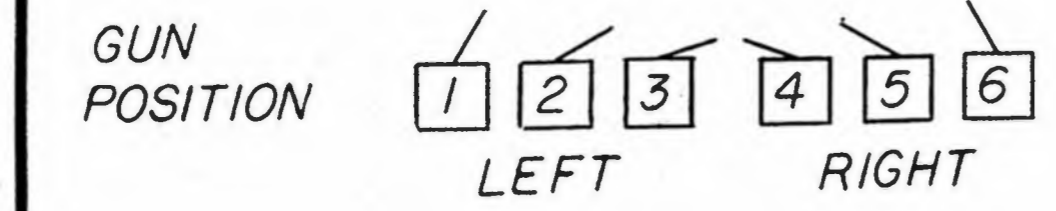
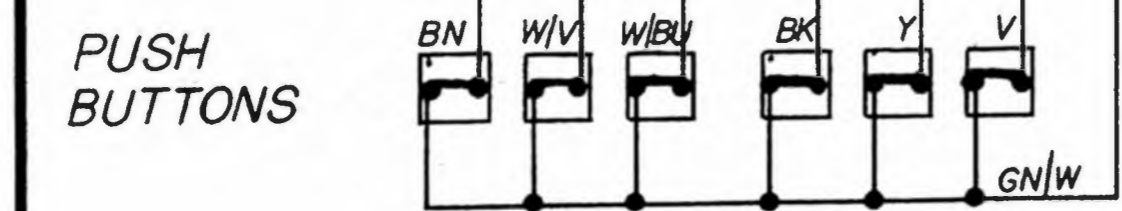

NOTICE TO ALL PERSONS RECEIVING THIS DRAWING
 CONFIDENTIAL: Reproduction Forbidden without the specific written permission of Atari Inc., Los Gatos, California. This drawing is only conditionally loaned, and neither receipt nor possession thereof confers or transfers any right in, or license to use, the subject matter of the drawing or any design or technical information shown thereon, nor any right to reproduce this drawing or any part thereof, except for manufacture by vendors for Atari Incorporated and for manufacture under the corporation's written license, no right to reproduce this drawing is granted or the subject matter loaned unless by written agreement with or written permission from the corporation.

APPLICATION	USED ON
	ANTI-AIRCRAFT
NEXT ASSY	

INTERPRET THIS DRAWING PER USAS1 Y14.5	DRAWN BY ELI	DATE 12/26/74	 ATARI INCORPORATED 14600 Winchester Boulevard Los Gatos, California 95030
UNLESS OTHERWISE SPECIFIED DIMENSIONS ARE IN INCHES TOLERANCES ON:	CHECKED		
FRACTIONS = ±1/16 .XX = ±.1	DESIGN ENGINEER <i>E. Shokal</i>	PROJECT ENGINEER	TITLE ANTI-AIRCRAFT ELECTRIC DWG
ANGLES = ±1° .XX = ±.03	DOCUMENT CONTROL		SIZE C
SURFACE FINISH ✓ .XXX = ±.010	APPROVED <i>Ben...</i>		DRAWING NO. 003001
MATERIAL:			REV B
			SCALE
			SHEET 1 OF 1

DRAWING NO.
003001
SHEET
1
REV
B



ASSEMBLY TITLE / ANTI-AIRCRAFT - MAIN HARNESS P/L A003093

PARTS LIST SPECIFICATION Page 1 of 1

Drawn
 Checked
 Proj. Eng. Mech. Eng. *[Signature]*
 Elec. Eng. *[Signature]* REV. C

Rev.	Description	Date	Apprv.	Rev.	Description	Date	Apprv.
△	PROD REI	1-13-75	<i>[Signature]</i>				
B	Rev per ECN 1074	1-17-75	<i>[Signature]</i>				
C	Rev Per ECN# 1478	6/9/75	<i>[Signature]</i>				

Item	Part Number	Qty.	DESCRIPTION
1	79-511122	1	Edge Connector, 22 pin
2	79-010	3	Solder Lug #10
3	79-07320V	2	Faston #187
4	78-24003	7	Tie Wrap, Screw Down Type (SSC2S-510)
5	79-511001	2	Connector Key
6	78-25001	A/R	Tie Wrap
7	78-28004	A/R	Flat Shrink Tubing
9	79-58028	2	Connector, 3 position (F), Molex #03-09-1033
10	79-58030	1	Connector, 6 position (F), Molex #03-09-1063
11	79-58036	1	Connector, 12 position (F), Molex #03-09-1122
12	79-58026	1	Connector, 12 position (M), Amp #1-480708-0
13	79-20214	7	Connector, Socket Amp #350550-1
14	79-20201	21	Connector, Socket Molex #02-09-1118
15	51-11844	A/R	Wire, 18 AWG, Yellow
16	51-11866	"	" " Blue
17	51-11859	"	" " Green/White
18	51-11800	"	" " Black
19	51-11899	"	" " White
20	51-11855	"	" " Green
21	51-12077	"	" 20 AWG Violet
22	51-12095	"	" " White/Green
23	51-12033	"	" " Orange
24	51-12044	"	" " Yellow
25	51-12096	"	" " White/Blue
26	51-12000	"	" " Black
27	51-12097	"	" " White/Violet
28	51-12055	"	" " Green
29	51-12099	"	" " White
30	51-12088	"	" " Grey
31	51-12090	"	" 20 AWG White/Black
32	51-12011	"	" " Brown
33	51-12022	"	" " Red
34	51-12093	"	" " White/Orange
35	51-12066	"	" " Blue

- NOTES:
1. DIMENSIONS ARE REFERENCED FROM DOT TO DOT OR DOT TO END OF TERMINATION POINT.
 2. INSTALL SCREW DOWN TIE WRAPS EXACTLY AS SHOWN.

SYM	DESCRIPTION	DETAILS and DATE		
		DRFTG	CHKD	ENGR
A	PROD REL	1-14-75	E.S.	AK
B	REV PER ECU 1074	1-17-75	E.S.	AK
C	REV PER ECU # 1478	6/1/75	E.S.	AK

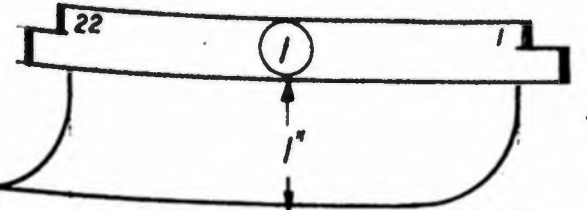

22 PIN EDGE COLLECTOR KEYS BETWEEN PINS 16 & 17, 18 & 19.

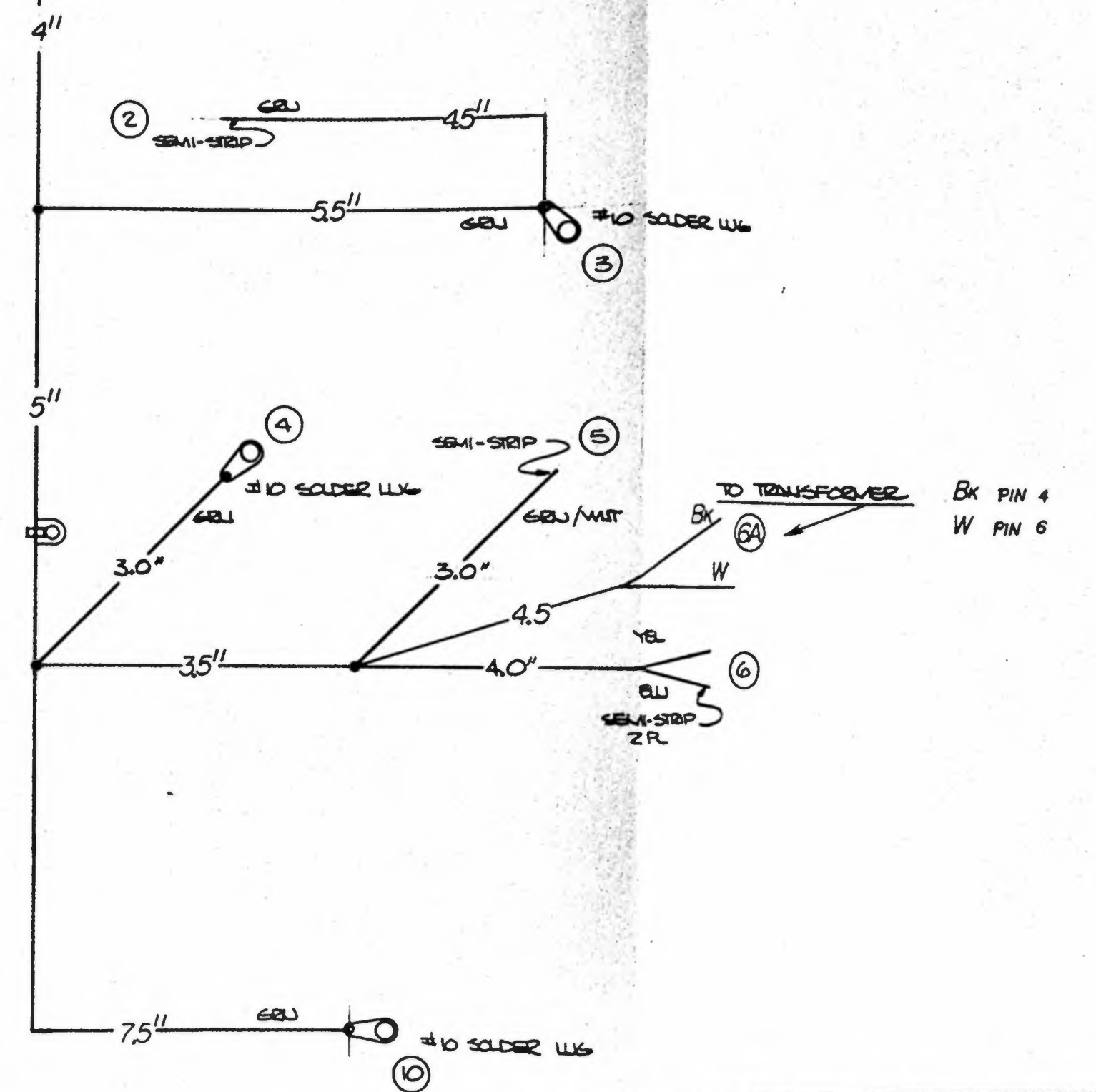
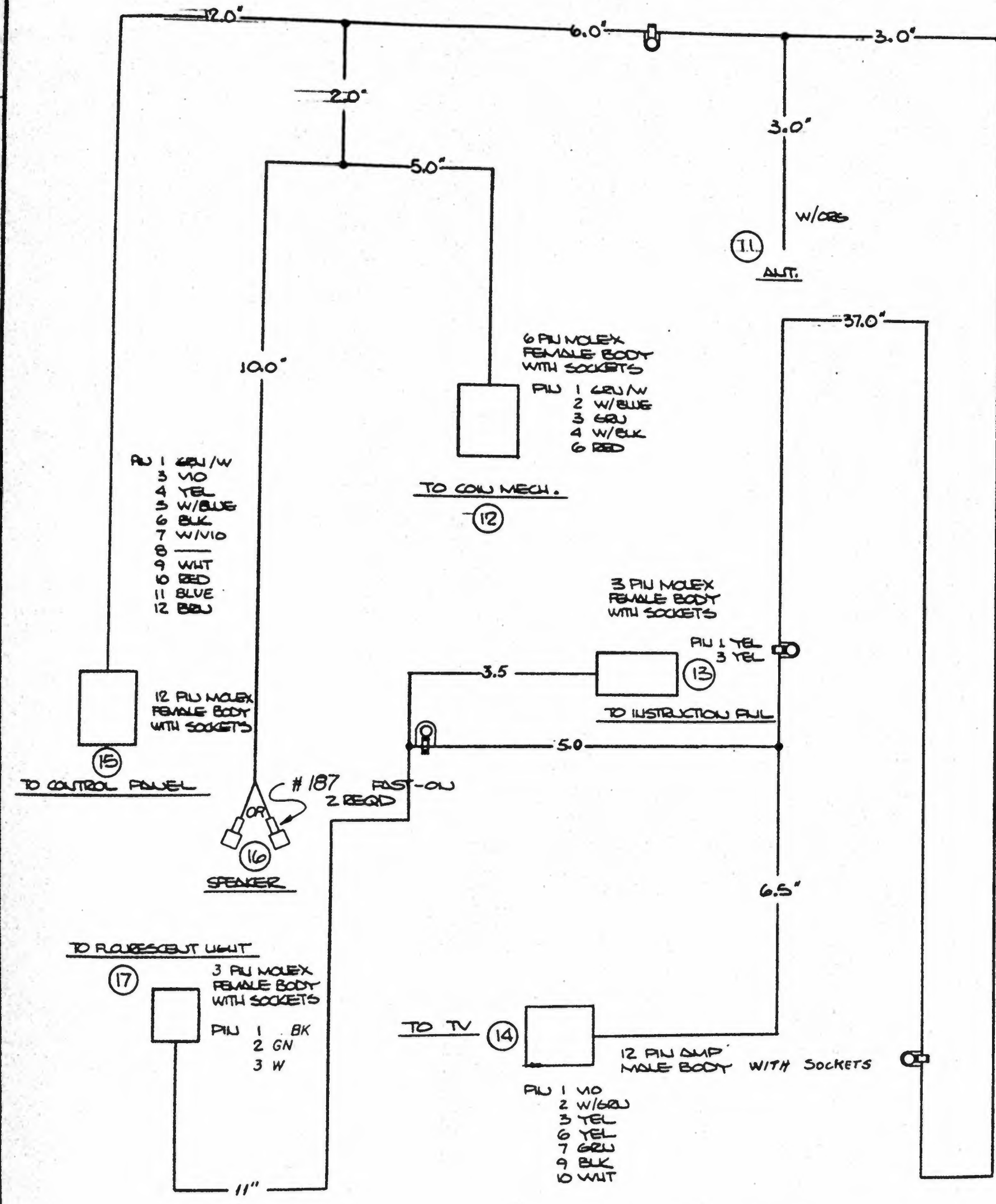

NOTICE TO ALL PERSONS RECEIVING THIS DRAWING: CONFIDENTIAL. Reproduction forbidden without the specific written permission of Atari Inc., Los Gatos, California. This drawing is only conditionally loaned, and neither receipt nor possession thereof confers to transferee any right in, or license to use, the subject matter of the drawing or any design or technical information shown therein, nor any right to reproduce this drawing or any part thereof, except for maintenance use by vendor for Atari Incorporated and the manufacturer under the corporation's written license, no right to reproduce this drawing is granted as the subject matter thereof unless by written agreement with or written permission from the corporation.

INTERPRET THIS DRAWING FOR US (11)	DATE
ENGINEER	1-7-75
DESIGN ENGINEER	
PROJECT ENGINEER	
DOCUMENT CONTROL	
MATERIAL	
SEE P. 003093	
ALTI-AIRCRAFT	
USED ON	
APPLICATION	

ATARI INCORPORATED 14000 Winchester Boulevard Los Gatos, California 95030	TITLE ANTI-AIRCRAFT MAIN HARNESS ASSY	SIZE D	DRAWING NO. AC03093	REV. C
SCALE FULL	DATE 1-7-75	BY COOK	CHKD AK	ENGR E.S.

5605000
1
LENS
C
A



ASSEMBLY TITLE / ASSY, CONTROL PANEL
ANTI-AIRCRAFT

P/L 003048

PARTS LIST SPECIFICATION

Page 1 of 1

Drawn

Checked

Proj. Eng

Mech. Eng. *P. TAKAICHI*

Elec. Eng. *J. [Signature]*

REV.
B

Rev.	Description	Date	Apprv.	Rev.	Description	Date	Apprv.
1	Prototype Rel						
A	PROD REL						
B	Rev per ECN 1266	1-9-75	<i>[Signature]</i>				
		3-23-75	<i>[Signature]</i>				

Item	Part Number	Qty.	DESCRIPTION
1	003049	1	Panel, Control
2	62-009	6	Switch, Push Button, Licon 76-7151
3	001856	7	Bushing, Switch
4	62-002	1	Switch, Push Button, Panel, MTG., LED Illum.
5	003050	1	Board, Control
6	A003100-02	1	Assy, Harness, Control Panel
7	72-6608	3	Screw, Sht. Met., Pan Hd, Phil, #6 x 1/2 Lg.
8	75-5124B	2	Bolt, Carriage, #10-24 x 1 1/2 Lg., Black
9	75-030S	2	Washer, Flat, Wide Pattern, #10
10	75-911S	2	Nut, Hex, #10-24



ASSEMBLY TITLE / ANTI-AIRCRAFT II PCB P/L000951

PARTS LIST SPECIFICATION Page 1 of 2

Drawn L LEPPERT
 Checked *Waters M. 2/21* Mech. Eng.
 Proj. Eng. *Larry Leppert* Elec. Eng

REV. B

Rev.	Description	Date	Apprv.	Rev.	Description	Date	Apprv.
A	Production Release	1-13-75	<i>Waters</i>				
B	REV. PER ECN 1145	2/21/75	<i>L. Leppert</i>				

Item	Part Number	Qty.	DESCRIPTION
1	10-0101	3	Resistor, Carbon Comp, 100 ohm, 1/4W, 10%
2	10-0102	22	" " 1K ohm " "
3	10-0103	4	" " 10K ohm " "
4	10-0105	3	" " 1 Meg " "
5	10-0153	2	" " 15K " "
6	10-0154	1	" " 150K " "
7	10-0181	1	" " 180 ohm " "
8	10-0184	1	" " 180K " "
9	10-0221	2	" " 220 ohm, " "
10	10-0223	1	" " 22K ohm, " "
11	10-0224	2	" " 220K ohm, " "
12	10-0274	1	" " 270K ohm, " "
13	10-0331	8	" " 330 ohm, " "
14	10-0333	4	" " 33K ohm, " "
15	10-0392	2	" " 3.9K ohm, " "
16	10-0472	1	" " 4.7K ohm, " "
17	10-0473	1	" " 47K ohm, " "
18	10-0474	2	" " 470K ohm, " "
19	10-0563	1	" " 56K " "
20	10-0564	1	" " 560K " "
21	10-52p7	1	" " 2.7 ohm, " 5%
22	10-5912	2	" " 9.1K " "
23	19-311103	1	Trim Pot, 10K ohm
24	19-311105	1	Trim Pot, 1 Meg
25	19-808W4PO	1	Resistor, Wire Wound, 4 ohm, 10W
26	21-101104	3	Capacitor, Mylar, .1mfd
27	21-101224	1	Capacitor, Mylar, .22mfd
28	24-060227	1	Capacitor, Electrolytic, 220mfd, 6V
29	24-100105	4	" " 1mfd
30	24-100106	3	" " 10mfd, 10V
31	24-100107	1	" " 100mfd, 10V
32	24-100225	1	" " 2.2mfd
33	24-100226	1	" " 22mfd
34	24-100475	2	" " 4.7mfd
35	24-100476	1	" " 47mfd
36	24-160108	1	" " 1000mfd, 16V
37	24-160477	1	" " 470mfd, 16V
38	24-160808	1	" " 8000mfd, 16V
39	27-101102	1	Capacitor, Ceramic, .001mfd

PARTS LIST SPECIFICATION

Item	Part Number	Qty.	DESCRIPTION
40	27-101103	2	Capacitor, Ceramic, .01mfd
41	27-120104	18	Capacitor, Ceramic Bypass, .1mfd
42	28-101101	2	Capacitor, Dipped Mica, 100pfd
43	29-013	2	Capacitor, Tantalum, 100mfd, 10%, 10V
44	31-414F	2	Diode, 414F
45	31-1N914	8	Diode, 1N914
46	31-1N4001	3	Diode, 1N4001
47	31-1N752A	1	Diode, 1N752A Zener
48	34-2N3643	4	Transistor, 2N3643
49	33-2N3644	1	Transistor, 2N3644
50	37-7400	10	Integrated Circuit, 7400
51	37-7402	10	" " 7402
52	37-7404	5	" " 7404
53	37-7408	6	" " 7408
54	37-7410	2	" " 7410
55	37-7413	1	" " 7413
56	37-7420	2	" " 7420
57	37-7427	1	" " 7427
58	37-7432	1	" " 7432
59	37-7448	1	" " 7448
60	37-7450	1	" " 7450
61	37-7474	12	" " 7474
62	37-7485	2	" " 7485
63	37-7486	5	" " 7486
64	37-7490	4	" " 7490
65	37-7493	3	" " 7493
66	37-74107	3	" " 74107
67	37-74153	7	" " 74153
68	37-9312	3	" " 9312
69	37-9316	13	" " 9316
70	37-9602	3	" " 9602
71	37-556	1	" " 556
72	37-566	1	" " 566
73	37-LM380	1	" " LM380
74	37-747	1	" " 747
75	37-4001	1	" " 4001
76			
77	37-LM323	1	Voltage Regulator, LM323
78	69-001	1	Switch, Slide, PC Mount, DPDT
79	90-101	1	Crystal, 14 MHZ
80	24-100505	2	Capacitor, Electrolytic, 5mfd
81	10-0273	2	Resistor, 27K, 1/4W, 10%
82	003127	1	Program, Anti-Aircraft Target
83	002092	1	P.C. BOARD

REVISIONS			
SYM	DESCRIPTION	INITIALS	DATE
A	PRODUCTION RELEASE		1/16/75
B	REVISED PER ECN 1148		1/16/75

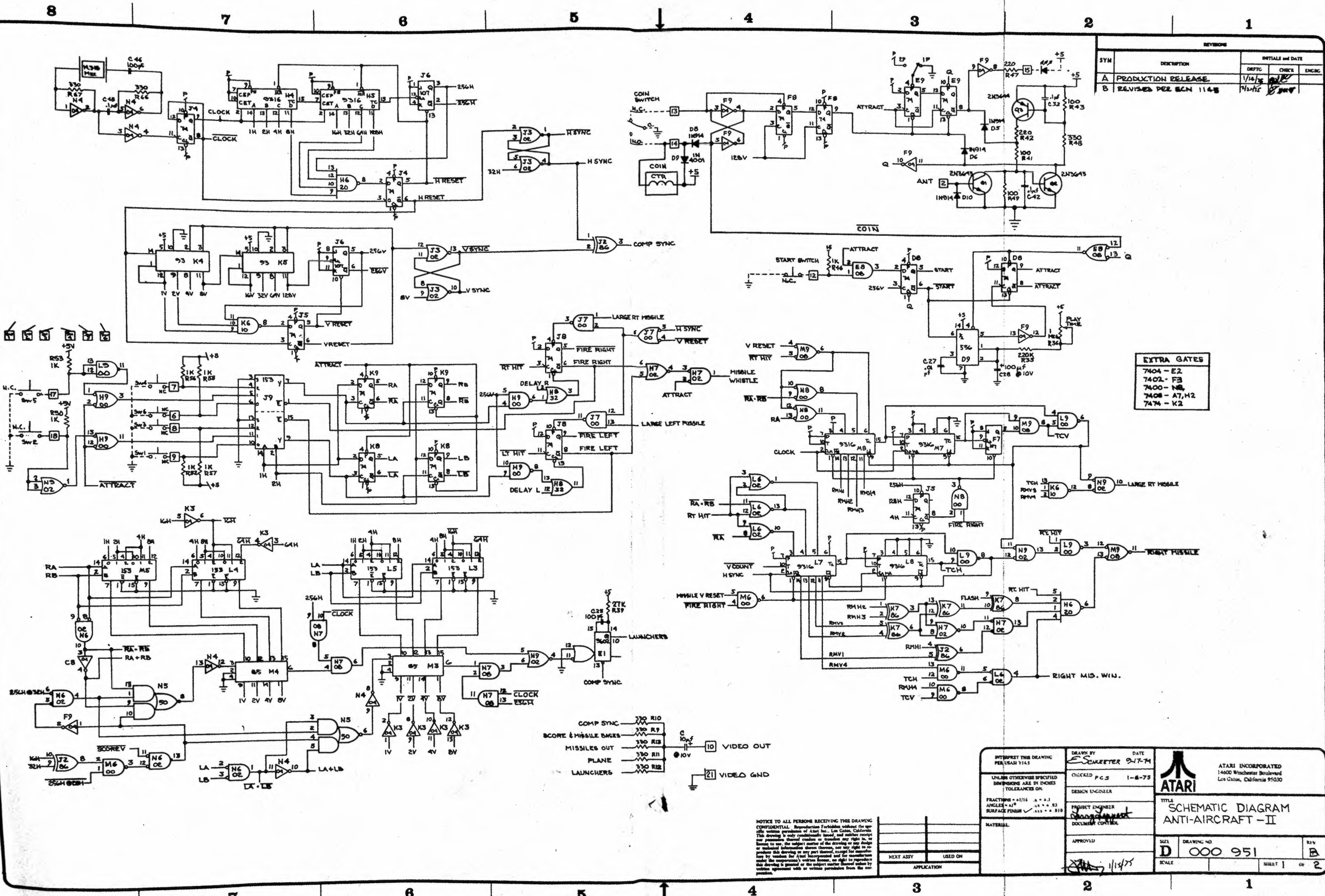

EXTRA GATES
 7404 - E2
 7402 - F3
 7400 - N8
 7408 - A7, H2
 7474 - K2

- COMP SYNC 330 R10
- SCORE & MISSILE BORG 330 R9
- MISSILES OUT 330 R8
- PLANE 330 R11
- LAUNCHERS 330 R12

NOTICE TO ALL PERSONS RECEIVING THIS DRAWING
 CONFIDENTIAL. Reproduction forbidden without the explicit written permission of Atari Inc., Los Gatos, California. This drawing is to be controlled, stored, and otherwise handled as a restricted document. No part of this drawing is to be reproduced, stored in a retrieval system, or transmitted in any form or by any means, electronic, mechanical, photocopying, recording, or by any information storage and retrieval system, without the prior written permission of Atari Inc., Los Gatos, California. All rights reserved.

INTEREST THIS DRAWING PER US 7143	DRAWN BY SCHREYER 917-74	DATE 1-8-75	 ATARI INCORPORATED 1400 Winchester Boulevard Los Gatos, California 95030
UNLESS OTHERWISE SPECIFIED DIMENSIONS ARE IN INCHES TOLERANCES ON:	CHECKED PCS	DESIGN ENGINEER	
FRACTIONS = 1/16 3/32 ANGLES = 15° 30° 45° 60° 90° 120° 135° 180°	PROJECT ENGINEER SCHREYER	DOCUMENT CONTROL	TITLE SCHEMATIC DIAGRAM ANTI-AIRCRAFT - II
MATERIAL	APPROVAL	SCALE	SIZE D
	NEXT ASSY	USED ON	DRAWING NO 000 951
	APPLICATION		REV B

156,000
 1
 B

Handwritten note: "High Counter"

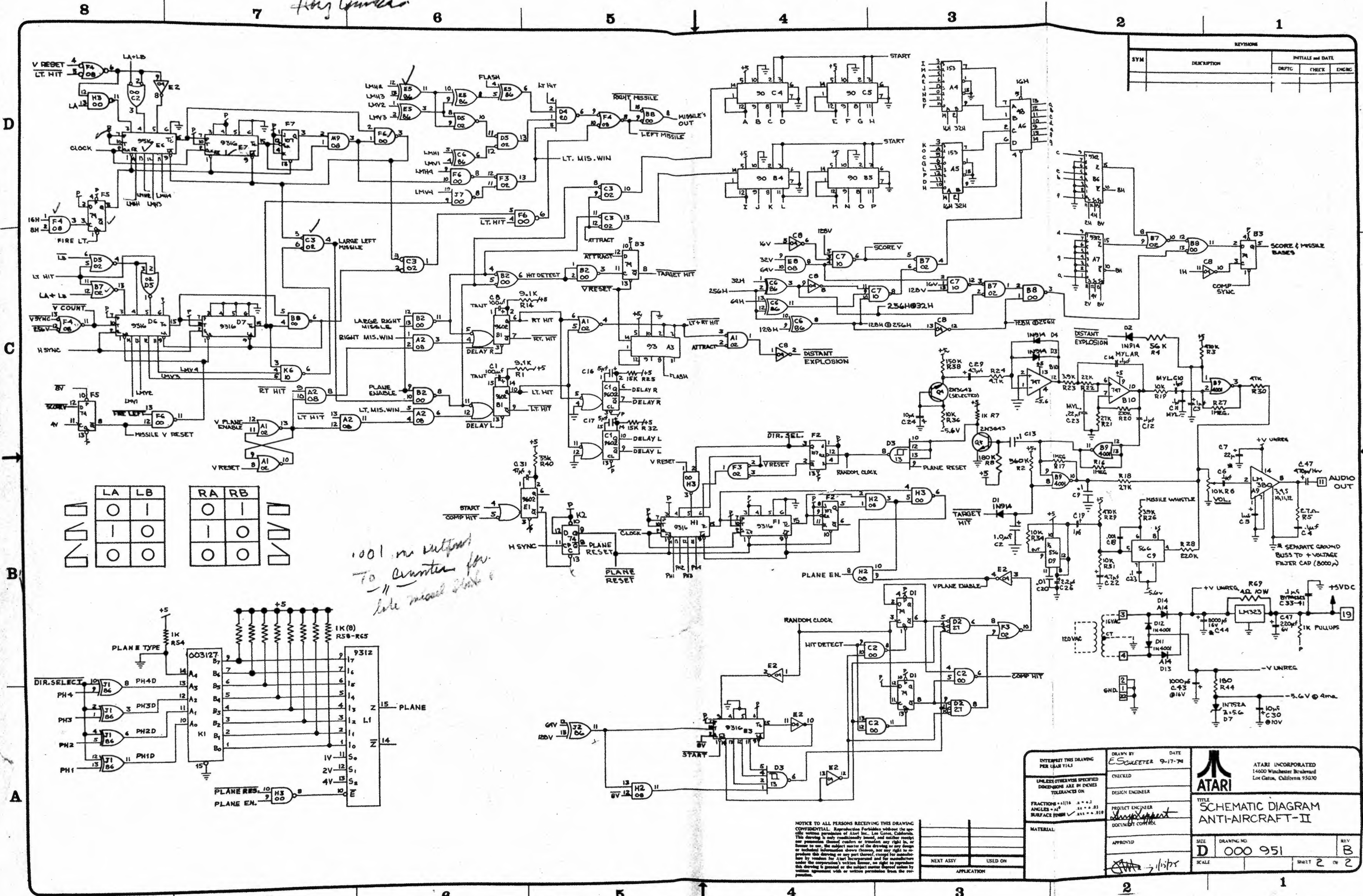

KEYWORDS			
SYM	DESCRIPTION	INITIALS AND DATE	
		DRFTC	CHECK
			ENGRG

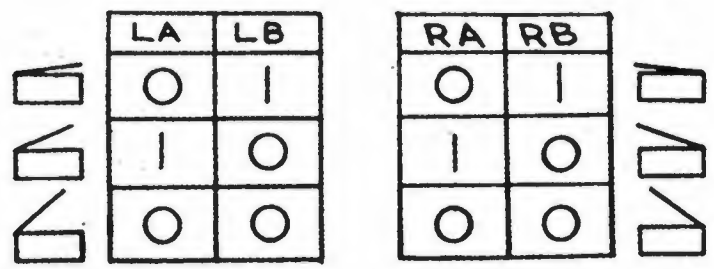

Handwritten note: "1001 no output to counter for late missile shot"

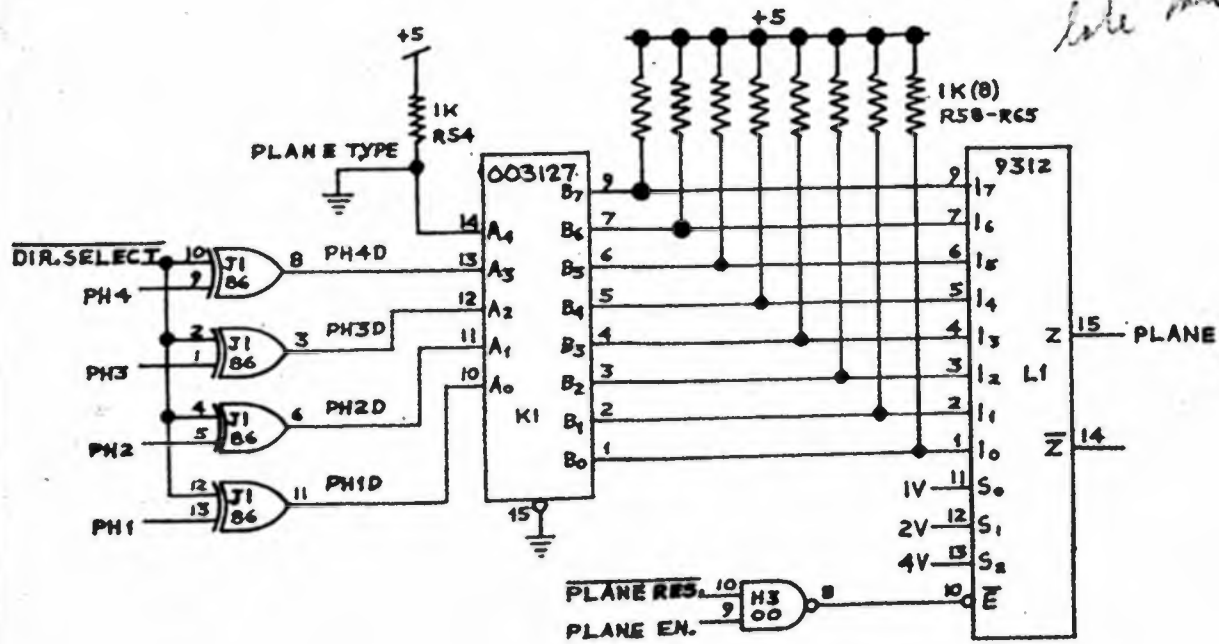

NOTICE TO ALL PERSONS RECEIVING THIS DRAWING
 CONFIDENTIAL. Reproduction forbidden without the specific written permission of Atari Inc., Los Gatos, California. This drawing is only conditionally loaned, and neither it nor any part of its contents are to be distributed, copied, or otherwise used in any way without the express written consent of Atari Inc. Atari Inc. reserves the right to modify this drawing or any part thereof, without notice, and without obligation to provide any such notice. Atari Inc. and its subsidiaries are not responsible for any damage or loss of any kind, including consequential damages, arising from the use of this drawing or any part thereof, or from the use of any information derived therefrom. Atari Inc. and its subsidiaries are not responsible for any damage or loss of any kind, including consequential damages, arising from the use of this drawing or any part thereof, or from the use of any information derived therefrom.

INTERPRET THIS DRAWING PER IASR 7143	DRAWN BY E. SCHRETER	DATE 9-17-74	 ATARI INCORPORATED 14500 Washington Boulevard Los Gatos, California 95030
UNLESS OTHERWISE SPECIFIED DIMENSIONS ARE IN INCHES TOLERANCES ON	CHECKED	DESIGN ENGINEER	
FRACTIONS = 1/16 3/32 1/8 1/4 3/8 1/2 5/8 3/4 7/8 1 1 1/4 1 1/2 1 3/4 2 2 1/4 2 1/2 3 3 1/4 3 1/2 3 3/4 4 4 1/4 4 1/2 4 3/4 5 5 1/4 5 1/2 5 3/4 6 6 1/4 6 1/2 6 3/4 7 7 1/4 7 1/2 7 3/4 8 8 1/4 8 1/2 8 3/4 9 9 1/4 9 1/2 9 3/4 10 10 1/4 10 1/2 10 3/4 11 11 1/4 11 1/2 11 3/4 12 12 1/4 12 1/2 12 3/4 13 13 1/4 13 1/2 13 3/4 14 14 1/4 14 1/2 14 3/4 15 15 1/4 15 1/2 15 3/4	PROJECT ENGINEER [Signature]	DOCUMENT CONTROL	 TITLE SCHEMATIC DIAGRAM ANTI-AIRCRAFT-II
MATERIAL	APPROVED	[Signature]	SIZE D DRAWING NO. 000 951 SCALE SHEET 2 OF 2
NEXT ASSY	USED ON	APPLICATION	REV B



ASSEMBLY TITLE AA FLOURESCENT LIGHT HARNESS P/L A003100-01

PARTS LIST SPECIFICATION Page 1 of 1

Drawn
 Checked *M.P. 3/24/75* Mech. Eng.
 Proj. Eng. Elec. Eng *Ch. Shochol* REV. B

Rev.	Description	Date	Apprv.	Rev.	Description	Date	Apprv.
△	PROD. #		SE				
B	Rev per ECN 1267	3-24-75	ES				

Item	Part Number	Qty.	DESCRIPTION
1	79-58043	1	Connector, 2 position, (M) body Molex #03-09-2022
2	79-58027	2	Connector Pins, Molex #02-09-2118
3	51-11800	A/R	Wire, 18 AWG, Black
4	51-11899	A/R	Wire, 18 AWG, White
5	78-25001	A/R	Tie Wraps



ASSEMBLY TITLE

ANTIAIRCRAFT CONTROL PANEL
HARNES

P/L A003100-02

PARTS LIST SPECIFICATION

Page 1 of 1

Drawn

Checked

M. J. 3/26/75

Mech. Eng.

Proj. Eng.

Elec. Eng.

El. Shueh

REV.

B

Rev.	Description	Date	Apprv.	Rev.	Description	Date	Apprv.
△	PROD REL		<i>R. Se</i>				
B	Rev per ECN 1267	3-24-75	<i>-S. J.</i>				

Item	Part Number	Qty.	DESCRIPTION
1	79-58037	1	Connector, 12 position, (M) body Molex #03-09-2121
2	79-58027	10	Connector pins Molex #02-09-2118
3			
4	79-07220V	16	Faston #110x20 Female
5	78-28004	A/R	Shrink Tubing
6	78-25001	A/R	Tie Wraps
7	78-24003	3	Screw down tie wrap (SSC2S-S10)
8	51-11859	A/R	Wire, 18 AWG, GN/W
9	51-12077	"	" " 20 AWG, Violet
10	51-12044	"	Wire " " Yellow
11	51-12096	"	" " " White/Blue
12	51-12000	"	" " " Black
13	51-12097	"	" " " White/Violet
14	51-12099	"	" " " White
15	51-12022	"	" " " Red
16	51-12066	"	" " " Blue
17	51-12011	"	" " " Brown



ASSEMBLY TITLE / ILLUMINUM BOARD HARNESS AA P/LA003100-03

PARTS LIST SPECIFICATION Page 1 of 1

Drawn
 Checked *M.J. 3/26/75* Mech. Eng.
 Proj. Eng. Elec. Eng. *E. Shueh* REV. B

Rev.	Description	Date	Apprv.	Rev.	Description	Date	Apprv.
	PROD REL						
B	Rev per ECN 1267	3-24-75	<i>ES</i>				

Item	Part Number	Qty.	DESCRIPTION
1	79-58027	1	Connector, 3 position (M) Body #03-09-2032
2	79-58027	2	Connector pins Molex #02-09-2118
3	51-12044	A/R	Wire, 20 AWG, Yellow
4	78-25001	A/R	Tie Wraps

8

7

6

5

4

3

2

1

REVISIONS				
SYM	DESCRIPTION	INITIALS and DATE		
		DRY TC	CHK	ENGR
A	PROD REL	1-18-75	ES	
B	REV PER ECU 1267	2-27-75	ES	B.P.

CONTROL FUEL HARNESS A003100-02

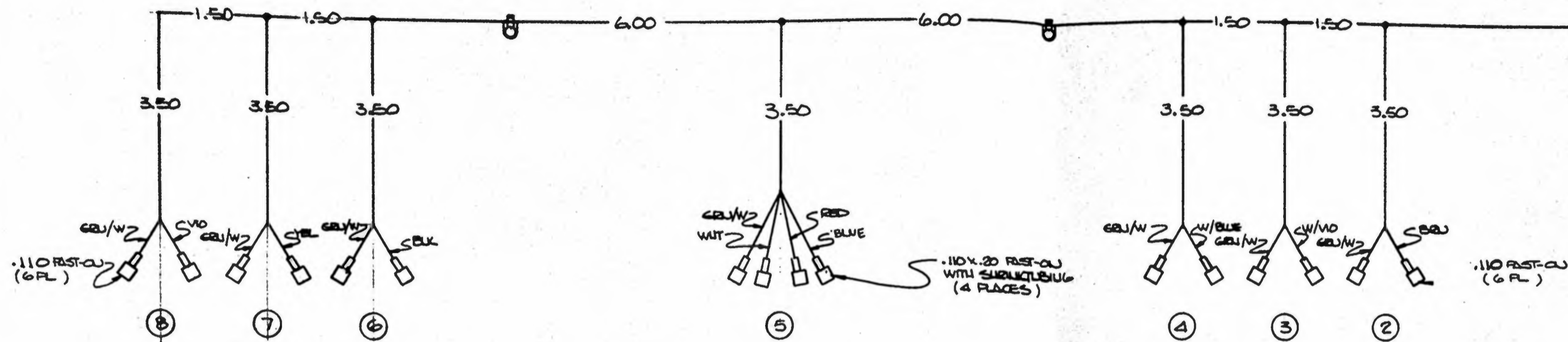

FLUORESCENT LIGHT HARNESS A003100-01

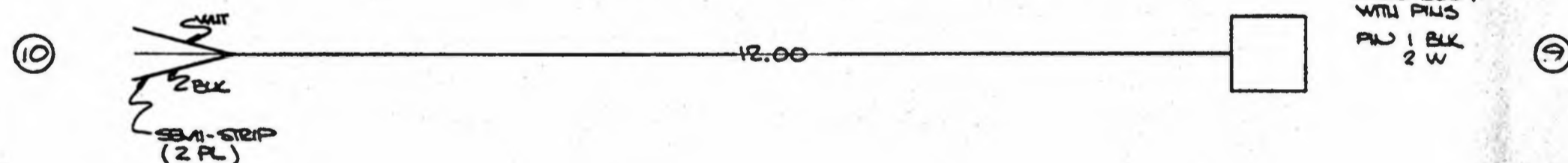

ILLUM. BD HARNESS A003100-03

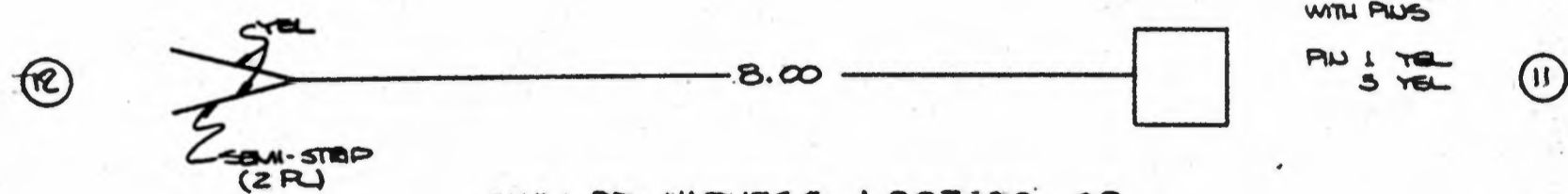

- NOTES:
1. DIMENSIONS ARE REFERENCED FROM DOT TO DOT OR DOT TO END OF TERMINATION POINT.
 2. INSTALL SCREW DOWN TIE WRAP EXACTLY AS SHOWN.

NOTICE TO ALL PERSONS RECEIVING THIS DRAWING
 CONFIDENTIAL. Reproduction Forbidden without the specific written permission of Atari Inc., Los Gatos, California. This drawing is only conditionally loaned, and neither receipt nor possession thereof confers or warrants any right in, or license to use, the subject matter of the drawing or any design or technical information shown therein, nor any right to reproduce this drawing or any part thereof, except for manufacture by contract for Atari Incorporated and for maintenance under the supervisor's written license, and right to reproduce this drawing is granted to the subject matter thereof unless by written agreement with or without permission from the corporation.

APPROVED	DATE
DATE	DATE
DATE	DATE
DATE	DATE

INTERPRET THIS DRAWING PER USAN 1141	DRAWN BY COOL	DATE 1-9-75	ATARI INCORPORATED 14600 Winchester Boulevard Los Gatos, California 95030
UNLESS OTHERWISE SPECIFIED DIMENSIONS ARE IN INCHES TOLERANCES ON:	CHECKED	DESIGN ENGINEER E. Vachal	
FRACTIONS = 1/16 1/8 1/4 1/2 1	PROJECT ENGINEER	DOCUMENT CONTROL M?	SIZE D
ANGLES = 15° 30° 45° 60° 90° 120° 150° 180°	APPROVED	SCALE FULL	DRAWING NO. A003100-XX
SURFACE FINISH = 321 - A 312	MATERIAL SEE P. A003100	REVISIONS	REV B
	APPLICATION	SCALE FULL	SHEET 1 OF 1

DRAWING NO. A003100-XX
 SHEET 1 OF 1