

CHECK OIL & DRAIN COMPRESSOR WEEKLY

BOLWELL FLIGHT SIMULATORS Series III

SERVICE MANUAL

FunTecnic, Inc.

Airport Plaza, 7370 N.W. 36th St.
Miami, FL 33166

Phone: (305) 592-5932 • Fax: (305) 592-6041



Service Direct Line
Phone: (313) 287-2510
Fax: (313) 287-2204

INDEX

	Page
Introduction	3
Specifications	3
Setup & Predelivery	4
Site Location	5
Preventive Maintenance	6
Removal & Refit of Subassemblies	8
Rectification of Basic Faults	9
Compressor of Basic Faults	11
Parts Listing	
Guide to Part Number System	15
Parts List	16
Electronic Schematics	20

1. INTRODUCTION

Bolwell flight simulators represent a significant breakthrough in children's amusement rides. Through exciting design and unique operating control they allow the rider to simulate flight, complete with dives, climbs and banks. Sound and light effects add to the atmosphere.

Because our flight simulators are more sophisticated in both appearance and operation, older kids ride them repeatedly. Indeed, instead of being limited to an age range of 2 to 6, flight simulators attract children up to 12 and beyond. Even adults will be seen flying these machines!

When a ride is started, the simulator automatically rises from the launch pad. Once at it's full height, the capsule can be banked to the left, right, forward (dive) or backward (climb) by moving the joystick. The trigger on the joystick controls the illuminated ranging pattern in the display panel located in front of the rider and produces a firing sound effect through the rear speaker (or in the case of the Turbochopper, a siren effect). The throttle control lever on the right hand side of the capsule controls the thrust sound effects and illuminated speed indicator.

An automatic pilot facility is available for younger children. Pressing the "AUTO" switch overrides the manual control and the craft simulates flight automatically.

2. SPECIFICATIONS (subject to change without notice)

	STARFIGHTER	TURBOCHOPPER
Model No:	BS-1	BS-2
Theme:	Earth Module	Search & Rescue
Weight:	140kg (310lb)	135kg (300lb)
Height:	1240mm (48")	1520mm (60")
Length:	1960mm (77")	2120mm (84")
Width:	1110mm (44")	1000mm (39")
	SKYHAWK RAIDER	STEALTH
Model No:	BS-3	BS-4
Theme:	Interceptor	Penetrator
Weight:	135kg (300lb)	135 Kg (300 lb)
Height:	1430mm (56")	1170mm (46")
Length:	2250mm (89")	2110mm (83")
Width:	1090mm (43")	1420mm (56")
AC Supply:	110/220 volts, 50/60 Hz to transformer	
AC Protection:	Earth leakage/ground fault detector	
Power Consumption:	1140 Watts (3.75 AMP @ 220 VAC) (7.5 AMP @ 110 VAC)	
Environmental Temperature:	0 - 45°C (32 - 120° F)	
Humidity:	Not more than 80% relative	
Actuation:	Pneumatic	
Compressor Protection:	1. Pressure relief valve 2. Heat sensitive cutout	
Lift Capacity:	Gross 340kg (750lb) Nett 290kg (640lb)	
Construction:	Low maintenance fiberglass capsule and base Fully molded interior Corrosion protected metal components Heavy duty mechanical components Modular, solid state electronics	

Coin Acceptor:	Adjustable, with washer check, or provision for electronic mechanism
Coin Counter:	Adjustable, 1 to 8 coins or tokens
Audit Meter:	Concealed, non-resettable, hard wired
Ride Length:	Adjustable, 30 seconds to 4.5 minutes
Speakers:	8 OHM 0.25 Watt, 1 internal, 1 external, variable balance

3. SETUP & PREDELIVERY

Each model requires a different procedure to make ready for predelivery.

- 3.1. BS1 Ready as delivered.
- 3.2. BS2 Requires fitment of jetpods, tail assembly and wheels
 - 3.2.1. Unpack jetpods and tail.
 - 3.2.2. Remove inner headrest panel.
 - 3.2.3. Remove the 3 location nuts from the tail strut bolts.
 - 3.2.4. Place tail onto the rear of the capsule and screw on the nuts from the inside (ensure that the large washers supplied are fitted between the nut and the inside fiberglass).
 - 3.2.5. Remove bolts from the jetpods.
 - 3.2.6. Position first jetpod and bolt into position. For security, sockethead bolts are used. Ensure that the large washers supplied are fitted inside under the nuts.
 - 3.2.7. Repeat for second jetpod.
 - 3.2.8. Tighten all bolts.
 - 3.2.9. Replace inner headrest panel.
 - 3.2.10. Bolt on wheels (fit silver plate on the inside of the base, black bracket on the outside).
- 3.3 BS3 Requires fitment of tail molding.
 - 3.3.1. Place tail on attachment land on top of capsule.
 - 3.3.2. Insert rivets.
 - 3.3.3. Pull up rivets.
- 3.4 BS4 Requires fitment of wing tips
 - 3.4.1. Place wings on attachment lands
 - 3.4.2. Insert rivets
 - 3.4.3. Pull up rivets

All machines are now ready for predelivery and test. Together with this manual is one tamper proof bolt tool, one bottle of compressor oil, one pair of coin mechanism keys and the warranty card. This card must be completed and returned without delay to the address indicated. This is essential to enable unit and component tracking and the processing of any claim under warranty; it will become part of the permanent records.

Prior to shipment from the factory, each simulator undergoes a detailed inspection program. Both cabinet and electronic components are checked for appearance and operation and each unit undergoes extended test. However, on receipt examine each simulator for any transport damage to the capsule, controls, light fittings or display panels. If any damage does exist, immediately claim on the carrier and notify your distributor.

After the external check has been completed, internal inspection is required. Lift the machine up from the front to expose the underside. Check the following items:

1. That all electronic components and connecting plugs are secure.
2. That all air lines and pneumatic fittings are secure.
3. That the coin selection switch located on the main power supply board is set to your requirements. NOTE: to reset this switch it is important to first switch all levers OFF, then turn ON only the desired lever. If more than one lever is set in the ON position, damage may result.

Lower the machine back to normal position.

1. Open the coin door and record the opening meter reading onto your warranty card. Mail card immediately.
2. Open the flap on the protective skirt. On the upper right side of the compressor is a transportation cap sealing the AIR INTAKE TUBE and holding a small plastic bag. Remove the cap and replace it with the AIR INTAKE FILTER from the bag. Retain cap for future use during transportation. (Some deliveries are made with the air filter in the cash box.)
3. Remove the STOP decal from the main circuit breaker and switch on.
4. Connect lead to power supply and turn on. Machine is now operating but will take a few minutes to reach operating pressure.
5. Check the regulated pressure guage and ensure that this is set at 30-35 PSI, (2 bar) maximum.
Under no circumstance can this be allowed to exceed 50 PSI (3.5 bar).
6. Check air system for leaks.
7. Close protective skirt.

Using the following check list, all functions can now be tested.

FUNCTION	CHECKED
Machine Turned On	
External attract lights working	[]
Auto switch light on	[]
Ride Activated	
Auto switch light off	[]
Joystick operation	[]
Ram operation	[]
Dash display operation	[]
Joystick trigger, display	[]
Joystick trigger, score accumulator	[]
Joystick trigger, sound	[]
Throttle, display	[]
Throttle, sound	[]
Base/pilot commentary, internal	[]
Base/pilot commentary, external	[]
Correct ride price, coin acceptance	[]

During this predelivery sequence the simulator should also be tested and reset as required for:

- a) Ride length (potentiometer VR1 on main power PCB)
- b) Internal and external commentary volume (potentiometer VR3 on main power PCB)
NOTE: sound speed can be adjusted using VR2 on main power PCB.
- c) Press AUTO switch. Switch should light up, and ride become automatic.

Note: For display purposes or prolonged testing, an override automatic switch is mounted on the main PCB. When activated, the craft will operate non-stop.

4. SITE LOCATION

Position the simulator in a protected area under cover and on a solid surface. Allow sufficient space around it for the circulation of customers, remembering that the capsule tilts sideways when in operation. Arrange the main power lead to avoid interference with the movement of people around the simulator. If possible, use a screw-on type electrical plug to avoid accidental disconnection. When selecting a location be aware that various city ordinances may apply; meet these to ensure compliance.

A well-kept, well maintained unit is far more attractive to potential riders (and their parents) than a unit which is allowed to deteriorate. Poor performance life and subsequently lower profits can be avoided by attention to the following:

1. Scheduled, regular cleaning, inside and out.
2. Maintain safety skirt in good condition.
3. Replace deteriorating decals.
4. Avoid rough handling.
5. Avoid locations which are excessively dusty or humid.
6. Avoid locations in direct sunlight.
7. Arrange a rapid response to service calls in the event of breakdown.

For the safety of riders and personnel, do not install any flight simulators where they will hamper or prevent the use of emergency equipment or building exits.

5. PREVENTATIVE MAINTENANCE

Bolwell flight simulators are very simple to maintain and offer many years of service. In addition to regular cleaning, it is important to observe the following simple instructions to maximize your service life. Note that provided these operational instructions are carried out your flight simulator is warranted against faulty material or workmanship for 12 months/50,000 rides. The warranty does not cover damage caused by violence, misuse, incorrect repairs or use of wrong oil and non-original spare parts.

MOST IMPORTANT:

ENSURE THAT THE PROTECTIVE SKIRT IS KEPT CLOSED WHENEVER CRAFT IS OPERATIONAL.

	1	2	3
Check compressor oil level. Correct level is between maximum and minimum levels of sight glass during standstill. Use only genuine SJ-27 synthetic oil. Do not overfill.	•		
Blow down air receiver (at a maximum pressure of 30 PSI) to drain moisture.	•		
Check compressor and air lines for leaks.		•	
Inspect and clean or replace air filter.		•	
Check for tightness all fasteners which are accessible to users.		•	
Check compressor visually and wipe with soft rag. If necessary, use paraffin on rag to remove sticky adhesions. Dust and dirt prevent cooling.		•	
Change oil (only necessary if oil appears dark and dirty in sight glass)			•
Operate safety valve by gently pulling protruding rod.			•
Thoroughly check ALL fasteners for tightness.			•
MAINTENANCE SCHEDULE:	1. WEEKLY	2. MONTHLY	3. ANNUALLY

CAUTION: AVOID ELECTRONIC DAMAGE!

Always ensure that electrical power is off before connection or disconnection of harnesses and/or PCB's.

Allow 1 minute after switch off for capacitors to discharge.

Despite having circuit protection, no IC's should be touched.

Handle PCB's carefully to avoid damage to components.

All PCB's are coated with silicone spray to protect against high humidity, condensation and contamination. Should rework be required, this coating will be cut through at normal soldering temperatures (above 130° C).

On completion this area should be resprayed.

Spare PCB's are shipped in anti-static material.

Do not unwrap until unit is required for use.

6. REMOVAL AND REFIT OF SUBASSEMBLIES

6.1. POWER SUPPLY PCB

- 6.1.1. Disconnect power supply cord.
- 6.1.2. Stand machine into vertical position.
- 6.1.3. Disconnect harnesses.
- 6.1.4. Remove four mounting bolts.

Reverse procedure to replace.

6.2. JOYSTICK

- 6.2.1. Disconnect power supply cord.
- 6.2.2. Stand machine into vertical position.
- 6.2.3. Disconnect harness from joystick.
- 6.2.4. Undo nyloc nuts.
- 6.2.5. Remove joystick assembly.

Reverse procedure to replace.

6.3. RAM

- 6.3.1. Disconnect power supply cord.
- 6.3.2. Remove protective skirt (Note: a slip tie is used to secure the band, which can be reused; see page 8.)
- 6.3.3. If a rear ram, remove upper retaining bolts through rear access holes.
- 6.3.4. Stand machine vertically. For front ram, remove upper retaining bolts through joystick access hole.
- 6.3.5. Disconnect air line from base of ram. This is a quick-connect fitting. Depress ring flange around air line and withdraw air line.
- 6.3.6. Undo lower retaining bolts & remove ram.

Reverse procedure to replace.

6.4. DISPLAY PCB

- 6.4.1. Stand machine vertically.
- 6.4.2. Disconnect display PCB harness at main PCB.
- 6.4.3. Lower machine to horizontal position.
- 6.4.4. Remove acrylic cover (in BS2, remove with bezel).
- 6.4.5. Remove display PCB with harness.

Reverse procedure to replace.

6.5 . SAFETY SKIRT (Refer to diagrams on next page)

- 6.5.1. Remove old skirt.
- 6.5.2. Fit skirt around unit.
- 6.5.3. Starting with top band, and with buckle held with legs pointing downwards and towards yourself (Figure 1) pass left hand end through buckle as shown in Figure 2.
- 6.5.4. Repeat this for the right hand side. Note that band can be fitted to allow easy removal and refitting if looped as per right hand side in Figure 3.
- 6.5.5. Tighten band, checking that the skirt is seated correctly. Do not pull very tight at this stage.
- 6.5.6. Repeat steps 2 through 4 with lower band.
- 6.5.7. To tension each band, press the band hard against the fiberglass on the right hand side rear corner and pull hard on the loop marked with an arrow in Figure 3.

Tying Safety Skirt Buckle

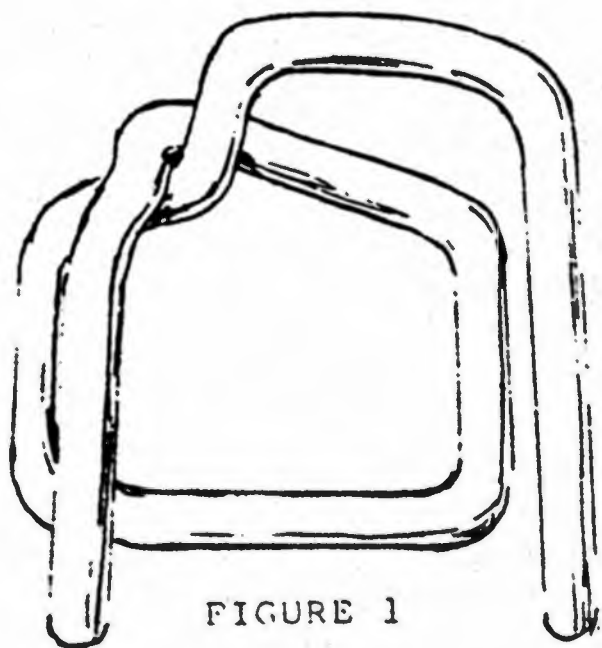

FIGURE 1

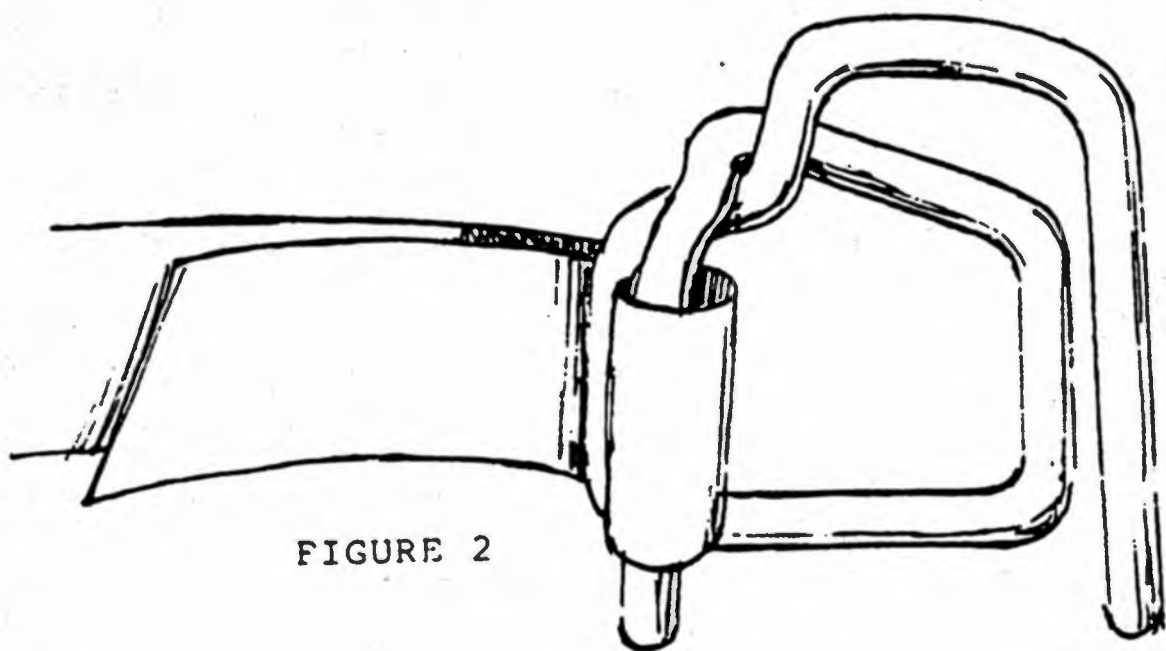

FIGURE 2

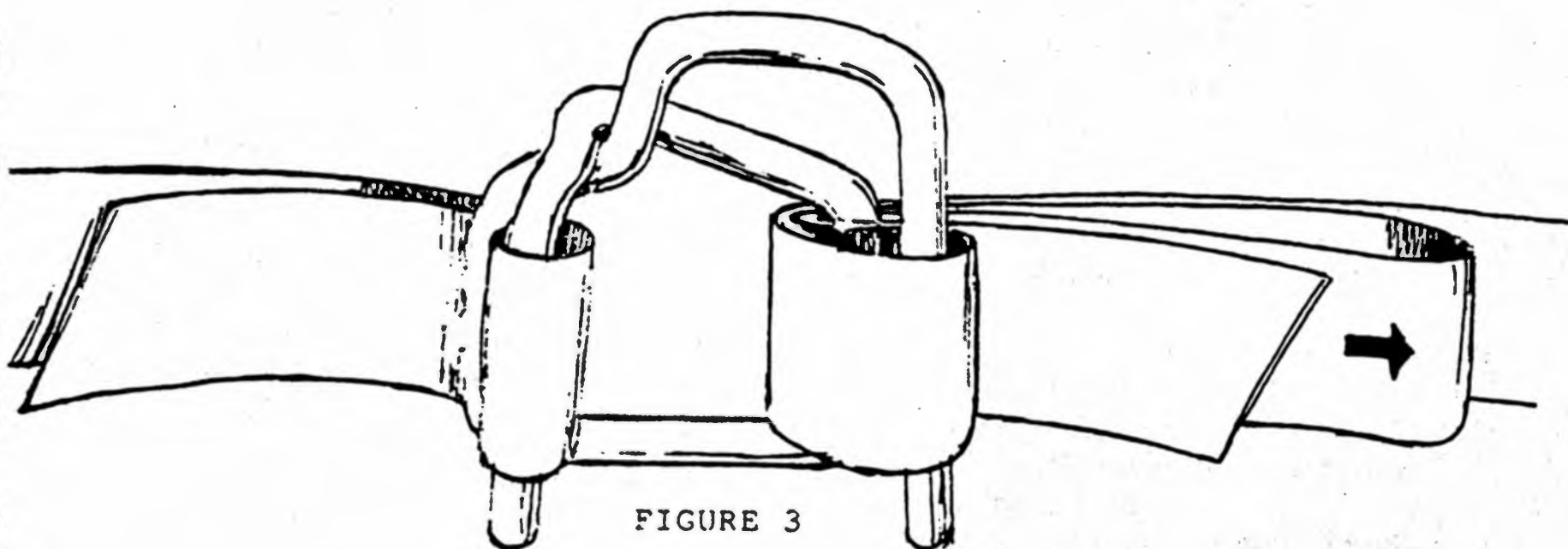

FIGURE 3

7. RECTIFICATION OF BASIC FAULTS

Fault

- * Ride will not run,
no external lights,
no auto switch light
- * Ride will run but external
attract lights do not work

Possible Cause

- * Turned off at plug
- * Power lead not plugged in
- * Circuit breaker tripped
- * Main building supply fuse blown
- * Harness plugs not connected
properly
- * Blown bulbs(s)
- * Blown fuse main PCB
- * Faulty triacs on main PCB

- * External attract lights work but ride will not start
 - * Harness plugs not connected properly
 - * Faulty coin credit on main PCB: check logic
 - * Faulty timer I.C. :- check logic
 - * Faulty switch on coin acceptor: check function with override switch button on main PCB
- * Coin lockout will not open, attract lights on
 - * Harness plugs not connected properly
 - * Blockage in coin acceptor
 - * Faulty lockout coil on coin acceptor
- * One or more rams will not work or one is noticeably slow
 - * Joystick harness not connected
 - * Joystick switch faulty
 - * Solenoid harness not connected properly
 - * Solenoid switch faulty
 - * Air leak
- * Earth leakage/ground fault detector trips regularly
 - * Short circuit in AC
 - * Faulty transformer(s)
 - * Unusual or irregular power supply characteristics
 - * Faulty circuit breaker
- * Money is inserted but machine not activated
 - * Faulty coin mech switch: remove and replace
 - * Faulty coin mech switch wiring
 - * Faulty main PCB: check logic
- * No base/pilot commentary
 - * Harness plugs not connected properly
 - * Volume control turned too low
 - * Faulty speaker
 - * Faulty power supply: test logic on main PCB
 - * Sound chip(s) not fitted correctly
- * No electronic sound effects: Joystick trigger
 - * Harness plugs not connected properly
 - * Faulty trigger switch on joystick (ranging display would not work either)
 - * Faulty display PCB: check logic
 - * Faulty speaker
- * Throttle
 - * Harness plugs not connected properly
 - * Faulty potentiometer on throttle control (speedo display would not work either)
 - * Faulty display PCB: check logic
 - * Faulty speaker
- * No electronic sound effects or visual displays (both functions)
 - * Harness plugs not connected properly
 - * Faulty display board: check logic

8. COMPRESSOR FAULT FINDING & REPAIR**IMPORTANT!**

1. SWITCH OFF CURRENT BEFORE REMOVING ANY PARTS FROM COMPRESSOR.
2. EMPTY AIR RECEIVER OF AIR BEFORE DISMANTLING ANY PART OF COMPRESSOR PRESSURE SYSTEM

8.1 Compressor does not start (no sound):

- a) No power from mains, check fuses and plug.
- b) Broken or loose electrical connections; test for continuity as per wiring diagram.
- c) Pressure in air-receiver too high for activation of pressure switch; empty receiver. The pressure switch makes a circuit only when the pressure has dropped to the preset start pressure.

8.2 Compressor does not start, but makes a buzzing sound followed by clicking noise:

- a) Voltage from mains too low. Compressor will work only at nominal voltage plus 115% minus 10%.
- b) Oil level incorrect. Motor cannot start if overfilled.
- c) Damaged top bearing (no. 45290). Replace bearing after having ground crankshaft with fine emery cloth. Clean thoroughly.
- d) Carbonizing. See points 8.5 c, d, e.
- e) Leaky non-return valve. Take off the flexible pressure pipe and check to see if air leaks from the valve. If so, clean or replace.

8.3 Compressor starts as usual, but switches off shortly afterwards (clicking noise):

- a) Voltage from mains too low; see point 8.2 a.
- b) Starting relay may be defective and does not switch off the start windings of the stator.
- c) Seized bearing or blockage of piston. See point 8.2 c. Ensure that rotor and connecting rod return freely.
- d) Ambient temperature is below freezing point. The thermal overload will switch off and on for a few minutes until all parts are properly lubricated.
- e) If the unit has been unused for a long time the thermal overload will switch off and on a few times, until all parts are properly lubricated (see point 8.3 d).

8.4 Compressor revolving slowly:

May be due to faulty starting relay, starting capacitor or stator.
See "Testing the Electrical Components".

8.5 Compressor works, but pressure does not increase in tank (or increases too slowly):

- a) The transportation cap has not been removed at the air intake tube and replaced with the air intake filter.
- b) Air filter clogged; clean or replace. On rare occasions, the filter pad may be sucked into the motor intake tube (if the pad has become oil soaked.)
- c) Valve plate defective, dirty, rusty, carbonized or broken. Replace and renew gaskets also.
- d) Internal pressure pipe carbonized or clogged. Clean thoroughly by strong compressed air blast or replace.

- e) Failure in non-return valve which is creating a flow restriction.
- f) Leaks in fittings, hoses or pneumatic equipment. Check with soapy water or by letting unit stay overnight disconnected from main power.

8.6 Loud noise from compressor:

- a) Most likely broken motor suspension spring(s). Replace spring and ensure that motor position is horizontal.
- b) Dirt in or failure of non-return valve; clean or replace.
- c) Internal pressure pipe (no. 45470) touches rib cover or cylinder block. Bend away.

8.7 Permanent air blow from pressure switch (115v models only):

- a) Leaky non-return-valve. See point 8.2 e.
- b) Unloader valve (release valve) on pressure switch defective

8.8 Compressor gets very hot and/or uses much oil:

- a) Oil level incorrect. The level must appear in the oil level glass.
- b) Wrong oil has been used in the compressor. Use only SJ-27 synthetic lubricant, which has the correct viscosity.
- c) Piston and cylinder worn.
- d) Air leaks; see point 8.5 f.
- e) Clogged intake filter; see point 8.5 b.
- f) Too high ambient temperature.

8.9 Compressor starts when no air is being tapped: Leaks; see point 8.5 f.

8.10 Compressor starts and stops more frequently than usual:

- a) Large amount of condensate in air-receiver.
- b) Leaks; see point 8.5 f.

8.11 Compressor does not switch on against pressure or does not switch off at max. pressure:

Defective pressure switch. Replace.

Adjustment of Pressure Switch:

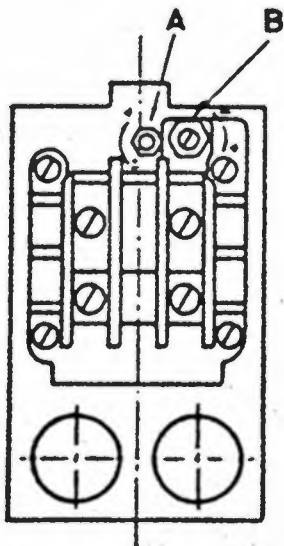

A: Max. pressure adjustment (cut-out)

B: Differential adjustment (cut-in)

The cut-out pressure is set by means of screw A. Turn clockwise to increase the switch-off pressure and counterwise to reduce it.

The cut-in pressure is set by means of the differential screw B (cut-out pressure + differential = cut-in pressure).

Turn clockwise to increase the differential.

Testing the Electrical Components:

In General:

Use an Ohm-meter (multimeter), which must be zero-positioned, before any measurements are made.

Starting Relay:

Test on the female sockets of the relay. A faultless relay will give no deflection on the scale of the instrument; a defective protector will give full deflection.

Overload Protector:

Test on the two poles of the protector. A faultless protector will give a full deflection on the scale; a defective protector will give no deflection.

Start-Capacitor:

Disconnect from mains before testing this. Short-circuit the two poles with an insulated screwdriver (or similar). A strong spark indicates that capacitor is all right.

For more precise examination test with the meter. A faultless capacitor gives a full deflection, which at once starts falling, due to capacitor being charged. Therefore, do not test for long as this will drain the batteries in the meter. If capacitor is more or less burnt out, there will be little or deflection.

Stator:

Test can be made on the internal AMP terminal or directly on the terminal plug on outside motor-casing (illustrated at bottom).

The following, average values apply to a faultless stator:

Cluster terminal wiring:	220 Volt	115 Volt
White-red	18.3 Ohms	5.2 Ohms
White-black	13.1 -	4.0 -
Black-red	5.2 -	1.2 -

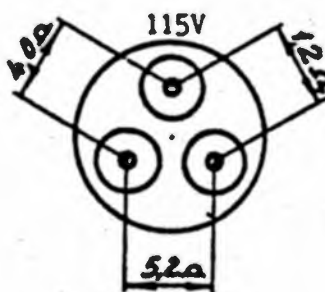
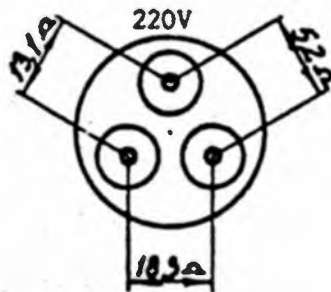

Wiring diagram Jun-Air compressor

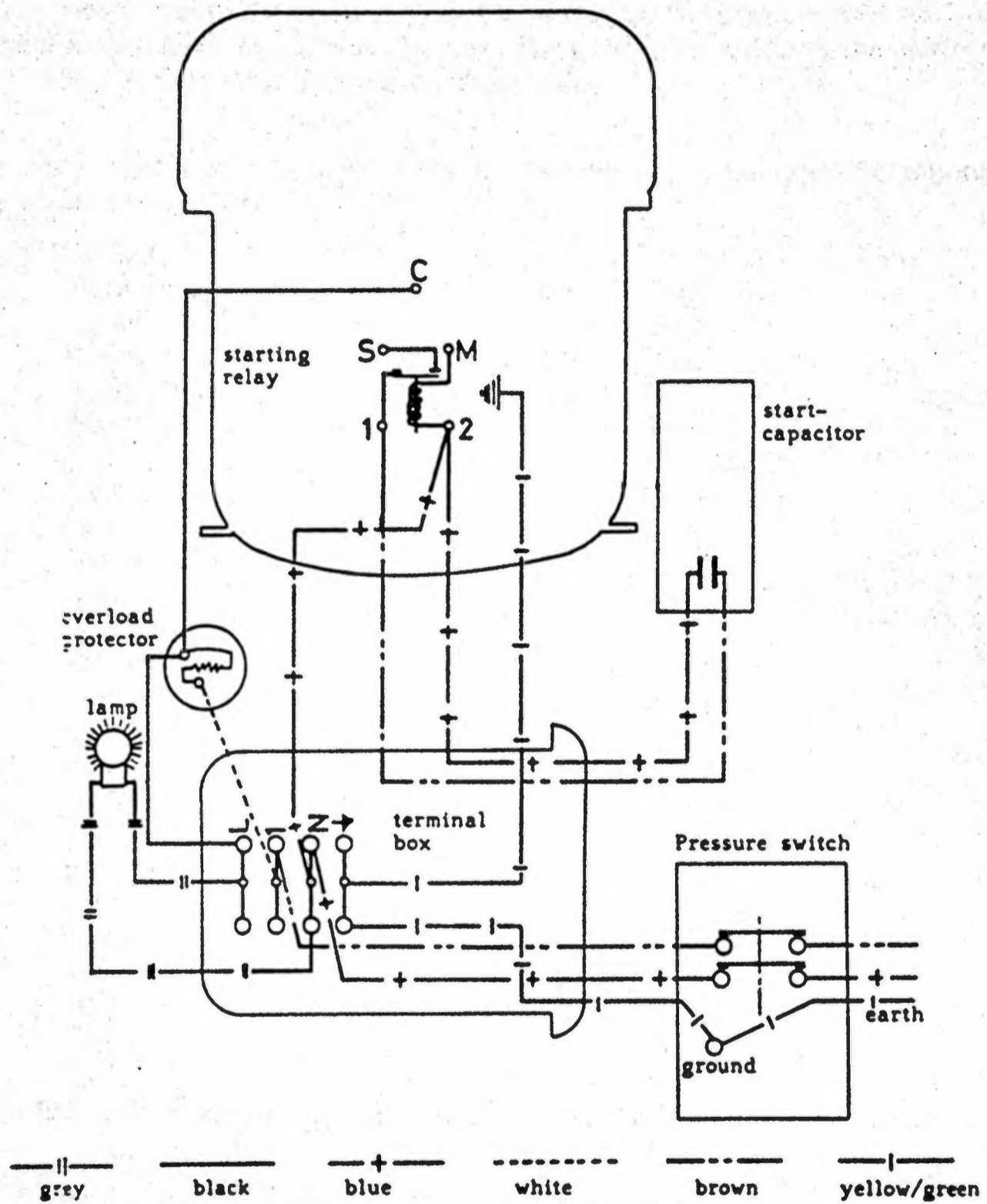

9. PARTS LISTING**Guide To Part Number System**

Part numbers are made up in the following manner.

BSX	04	003	B
Prefix	Type	Number	Suffix

1. Prefix

The first two letters of the prefix are used internally by the manufacturer and are not essential for the field recognition of a part. The third letter indicates the model number. If this is X, the part is common to all models.

2. Type

These are numbers from 01 to 99. Each number represents one type of component. They are listed as follows.

Part Description Code

02	Harness	03	Plug
04	Cable	05	Tube
07	Cover	08	Pad
09	Bush	10	Ram
12	Plate	13	Spacer
14	Rod	15	Molding
16	Handle	17	Coin Mech
18	PCB	20	Lock
22	Transformer	24	Relay
25	Clip	27	Meter
28	Coin Box	30	Bolt
33	Skirt	35	Switch
36	Bracket	37	Wheel
38	Joystick	39	Decal
41	Bulb	42	Panel
43	Dish	44	Speaker
45	Rivet	48	Potentiometer
50	Washer	52	Connector
53	Fuse	54	Grommet
55	Motor	61	Tank
66	Valve	68	Capacitor
69	Filter	70	Lubricant
71	Gasket	75	Fan
98	Tool		

NOTE: This is an essential group of numbers for the recognition of a part.

3. Number

These are numbers from 001 to 999 and are given numerically to parts within each type category.

NOTE: This is an essential group of numbers for the recognition of a part.

4. Suffix

This is a single letter and will only appear on the part number in the following circumstances:

- a) If a part has been revised but is essentially the same part and type of part, the suffix will reflect the revision to its specifications. All parts commence to specification A, which remains silent. If a revision is introduced to these specifications then the B suffix is used. If a further revision is required the suffix becomes C, and so on.
- b) If a part is obsolete it will have the suffix X.

PARTS LIST

Part No.	Description
BS1 02 006	Harness - flashing lights
BS2 02 007	Harness - flashing lights
BS3 02 008	Harness - flashing lights
BS4 02 009	Harness - flashing lights
BSX 02 012C	Harness - speakers
BSX 02 014D	Harness - coin mechanism
BSX 02 015C	Harness - throttle
BSX 02 017B	Harness - joystick
BSX 02 022	Harness - autoride switch
BSX 02 023	Harness - main supply
BSX 02 024	Harness - hivolt, compressor/cutout
BSX 02 028	Harness - ELCB/cutout
BSX 02 029	Harness - ribbon display
BSX 02 030	Harness - fan
BSX 02 031	Harness - coin mechanism, electronic
BCX 03 005	Plug - oil fill
BCX 03 006	Plug - air intake, transport
BSX 04 001	Cable - 10 AMP, 2.25 m w/110V Plug
BSX 04 002	Cable - 10 AMP, 2.25 m
BSX 05 009	Tube - Air, Tank/Solenoid
BSX 05 010	Tube - Air, Solenoid/Ram
BCX 05 011	Tube - braided, compressor/tank 135 mm
BSX 05 012	Tube - braided, tank/cut out 525 mm (110V)
BSX 05 013	Tube - flexible, coin 40 x 500 mm
BSX 05 014	Tube - flexible, coin 50 x 375 mm
BSX 05 017	Tube - coin reducer
BSX 05 018	Tube - coin flange, lower
BSX 07 002B	Cover - A/C Circuit
BCX 07 004	Cover - glass, pressure guage
BCX 07 005	Cover - glass, oil level
BSX 08 001	Pad - Base mounting
BSX 08 006	Pad - Nonskid 100 x 280
BS1 08 009	Pad - Nonskid 50 x 140
BSX 09 003	Bush - Locating rod
BCX 09 004	Bush - Joystick
BSX 10 002	Ram - Air
BSX 12 002C	Plate - Identification
BSX 12 003	Plate - 60C, 3 x 20C
BSX 12 004	Plate - 40C, 2 x 20C
BSX 12 006	Plate - 50C, Use Quarters Only
BSX 12 007	Plate - \$3, 3 x \$1
BSX 12 008	Plate - \$2, 2 x \$1
BSX 12 009	Plate - 75C, Use Quarters Only
BSX 12 010	Plate - 50C, 1 x 50C
BSX 12 012	Plate - Warning, High Voltage
BSX 12 015	Plate - 25C, Use Quarters Only
BSX 12 018	Plate - Coin mech locking
BSX 12 020	Plate - throttle

PARTS LIST

Part No.	Description
BSX 13 007	Spacer - Joystick, Convolved
BSX 14 001	Rod - Locating, short
BSX 14 002	Rod - Locating, long
BS1 15 001B	Molding - Capsule
BS2 15 002B	Molding - Capsule
BS3 15 003B	Molding - Capsule
BS2 15 015	Molding - Jetpod
BS2 15 016B	Molding - Tail LHS
BS2 15 017B	Molding - Tail RHS
BC2 15 018	Molding - Headrest
BC2 15 020	Molding - Dash, pod
BC2 15 021	Molding - Dash, backplate
BC2 15 022	Molding - Dash, bezel
BSX 15 029	Molding - Base, Air
BS3 15 030	Molding - Tail
BS4 15 031	Molding - Capsule
BSX 15 032	Molding - Tray
BS4 15 033	Molding - Wing LHS
BS4 15 034	Molding - Wing RHS
BSX 15 035	Molding - Coin shute
BS4 15 039	Molding - Dash display
BS4 15 040	Molding - Rear LHS
BS4 15 041	Molding - Rear RHS
BS4 15 042	Molding - Rear
BCX 16 001B	Handle - Throttle
BCX 16 002	Handle - Joystick, assembly
BCX 16 003	Handle - Joystick, moldings only (pair)
BSX 17 001B	Coin Mech - Locking, U.S.A. 25C
BCX 17 002B	Coin Mech - Locking, N.Z. 50C
BCX 17 003B	Coin Mech - Locking, H.K. \$1
BCX 17 004B	Coin Mech - Locking, Canada 25C
BCX 17 005B	Coin Mech - Australia 20C
BS1 18 004C	PCB - BS1 Display
BS2 18 005C	PCB - BS2 Display
BS3 18 006C	PCB - BS3 Display
BSX 18 009B	PCB - Main Supply
BCX 20 001	Lock - Coin Door
BCX 20 002	Lock - Coin Mech
BSX 22 003C	Transformer - 25V 5 amp
BCX 24 002	Relay - Display board
BCX 24 004	Relay - Starting, 220V
BCX 24 005	Relay - Starting, 110V
BSX 25 012	Clip - Safety skirt
BSX 27 001	Meter - 12V DC
BSX 27 003	Meter - Air pressure
BSX 28 005	Coin box
BSX 30 004	Bolt - Tamper proof, M4 x 25
BSX 33 013	Skirt - Safety

PARTS LIST

Part No.	Description
BCX 35 002	Switch - Micro, coin selector
BCX 35 003	Switch - Joystick trigger, leaf
BCX 35 004	Switch - Circuit Breaker/ Ground Fault Detect
BSX 35 009	Switch - Autotide
BCX 35 010	Switch - Solenoid valve & Coil
BCX 35 011	Switch - Overload protect, 220V
BCX 35 012	Switch - Overload protect, 110V
BCX 35 013	Switch - Pressure, complete, 220V
BCX 35 014	Switch - Pressure, complete, 110V
BCX 35 015	Switch, Joystick leaf
BCX 35 016	Switch, Joystick trigger, button
BSX 36 002	Bracket - Bulb holder
BSX 36 005	Bracket - Castor
BSX 37 001	Wheel - Castor
BSX 38 001	Joystick
BS1 39 001	Decal - Starfighter
BS1 39 002	Decal - BS1, Earth Module
BS1 39 004	Decal - Flight Simulator
BSX 39 005	Decal - Flag, Australia
BSX 39 006	Decal - Max. Thrust
BSX 39 007	Decal - Step
BSX 39 009	Decal - Line 1
BSX 39 011	Decal - Line 2
BSX 39 015	Decal - Stand Clear
BSX 39 016B	Decal - Operating Instructions
BS2 39 018	Decal - Turbochopper
BS2 39 019	Decal - BS2 Search & Rescue
BS2 39 020	Decal - BS2
BS3 39 023	Decal - Skyhawk Raider
BS3 39 024	Decal - BS3
BS3 39 025	Decal - BS3 Interceptor
BSX 39 029	Decal - Flag, U.S.A.
BSX 39 030	Decal - Flag, Canada
BSX 39 031	Decal - Flag, Hong Kong
BSX 39 032	Decal - Flag, New Zealand
BSX 39 035	Decal - Flag, Saudi Arabia
BSX 39 036	Decal - Flag, Taiwan
BSX 39 041	Decal - Base, Front
BSX 39 043	Decal - Stop
BS4 39 050	Decal - BS4 Penetrator
BS4 39 051	Decal - Stealth
BS4 39 052	Decal - Flight Simulator
BS4 39 053	Decal - 21943
BS1 41 002	Bulb - Festoon, 24 V 18 W
BSX 41 003	Bulb - Festoon, 24 V 10W
BCX 41 007	Bulb - Push Button 14V
BCX 41 008	Bulb - Power Indicate, 220V
BCX 41 009	Bulb - Power Indicate, 110V
BS1 42 002	Panel - Acrylic Dash, Printed

PARTS LIST

Part No.			Description
BS1	42	003	Panel - Acrylic Front, Yellow
BS1	42	004	Panel - Acrylic Side, Yellow
BS1	42	005	Panel - Acrylic Rear, Red Small, printed
BS1	42	006	Panel - Acrylic Rear, Red Large, printed
BS2	42	008	Panel - Acrylic Dash, Printed
BS2	42	009	Panel - Acrylic Front, Yellow
BS2	42	010	Panel - Acrylic Rear, Yellow
BS3	42	012	Panel - Acrylic Dash, Clear
BS3	42	013	Panel - Acrylic Dash, Printed
BS3	42	014	Panel - Acrylic Front, Orange
BS3	42	015	Panel - Acrylic Rear, Red
BS4	42	016	Panel - Acrylic Dash, printed
BS4	42	017	Panel - Acrylic Front, Orange
BS4	42	018	Panel - Acrylic Rear, Orange, printed
BSX	43	001	Dish - Spun, Small
BS1	43	002	Dish - Spun, Large
BSX	44	001	Speaker - 2"
BSX	44	004	Speaker - 3"
BSX	45	003	Rivet - Nutsert, Rubber 4mm
BSX	48	002	Potentiometer - Rotary Dual
BSX	50	007	Washer - Plastic cup
BSX	50	011	Washer - Bush Retaining
BSX	52	001	Connector - Junction Box
BCX	53	002	Fuse - 10 AMP
BSX	54	002B	Grommet - Power Supply Lead
BCX	54	003	Grommet - Compressor Mount
BCX	55	002	Motor - Compressor Assembly, 220V
BCX	55	003	Motor - Compressor Assembly, 110V
BSX	56	003	Tie - Skirt Retaining
BSX	61	001	Tank - Air Receiving
BSX	63	001	Door, Coin Sonusco
BSX	66	002	Valve - Air Exhaust & Silencer
BCX	66	003	Valve - Safety, Air
BCX	66	004	Valve - Air Tank Drain
BCX	66	005	Valve - Air Tank One Way
BCX	68	001	Capacitor - Start, 220V
BCX	68	002	Capacitor - Start, 110V
BCX	69	001	Filter - Air Intake
BCX	70	001	Lubricant - SJ-27 Oil, Bottle
BCX	70	002	Lubricant - SJ-27 Oil, 5 litre
BCX	71	001	Gasket - Oil Fill Plug
BSX	75	001	Fan - 220 volt
BSX	75	002	Fan - 110 volt
BSX	98	002	Tool - Tamper Proof Bolt Key

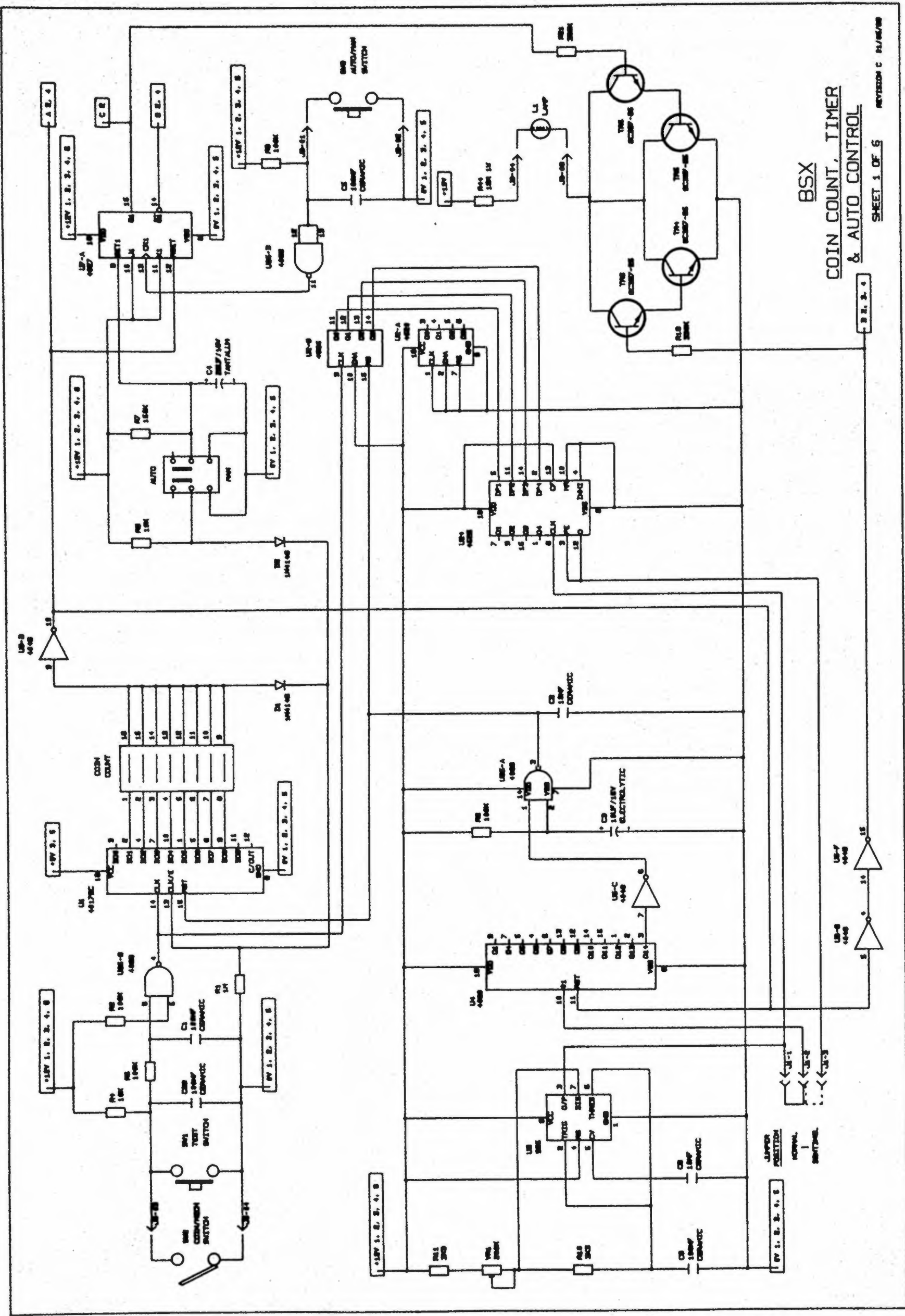

BSX
 COIN COUNT, TIMER
 & AUTO CONTROL

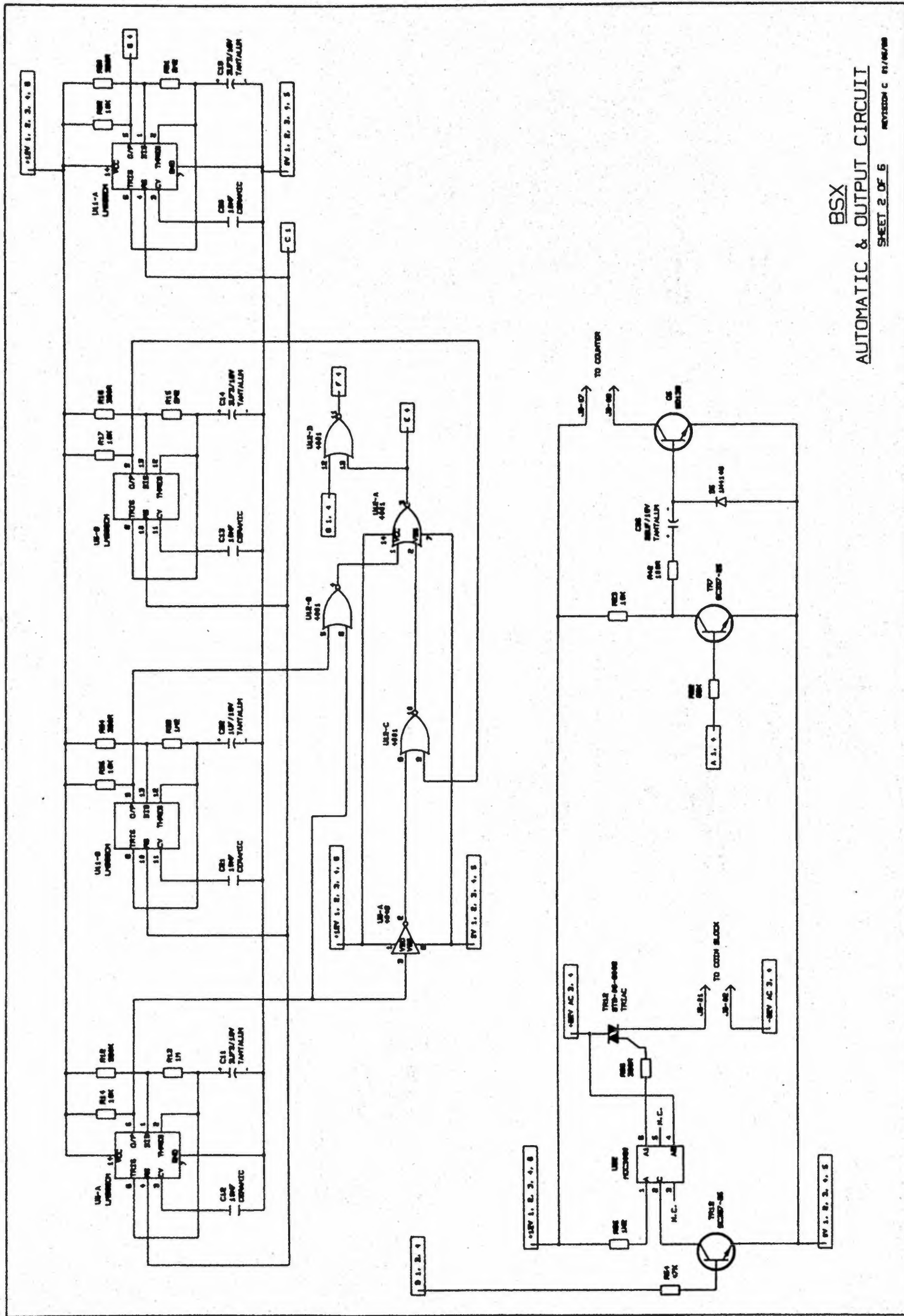

BSX
AUTOMATIC & OUTPUT CIRCUIT II

SHEET 2 OF 6

REVISION C 01/06/00

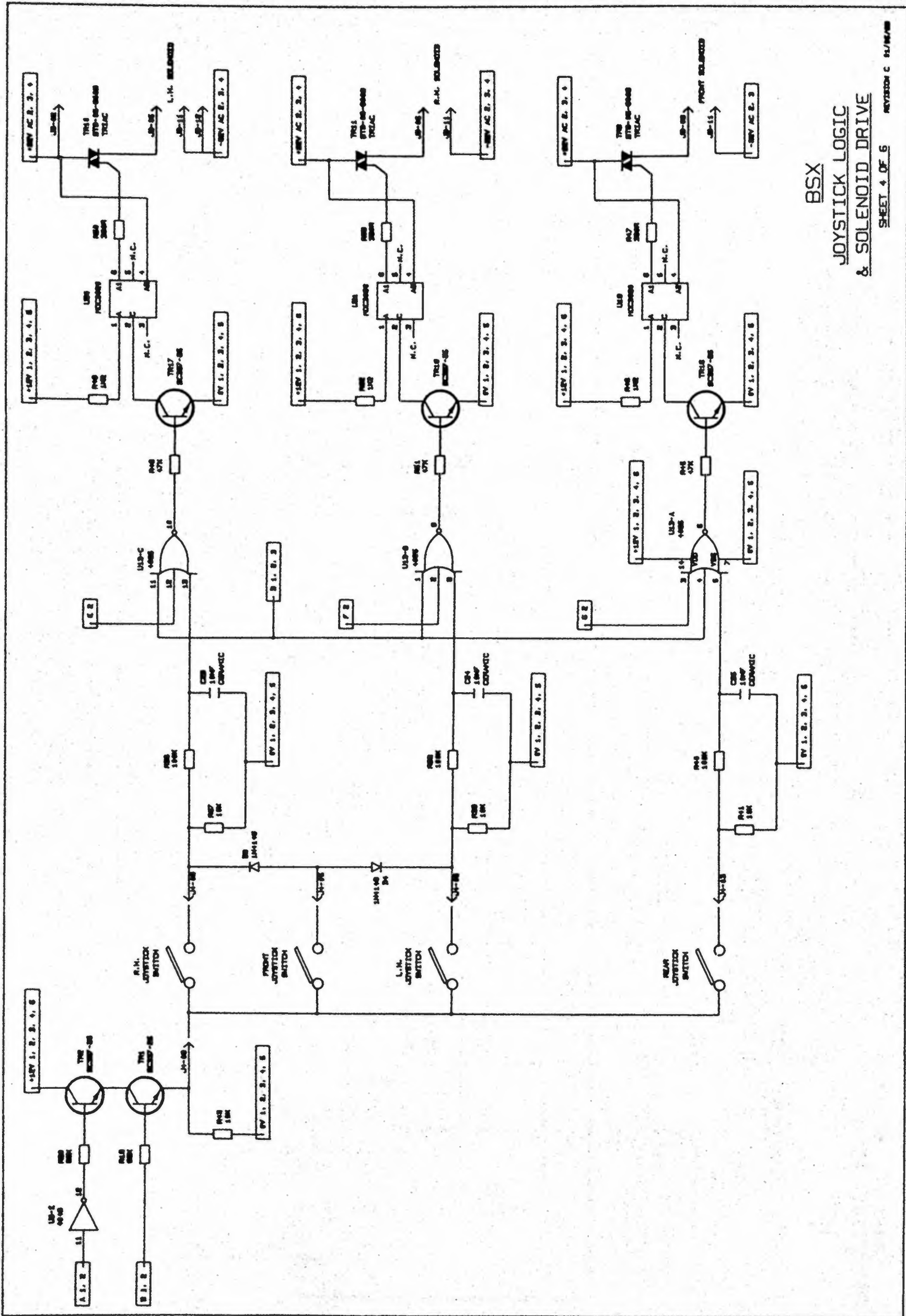

BSX
JOYSTICK LOGIC
& SOLENOID DRIVE

SHEET 4 OF 6

REVISION C 91/10/10

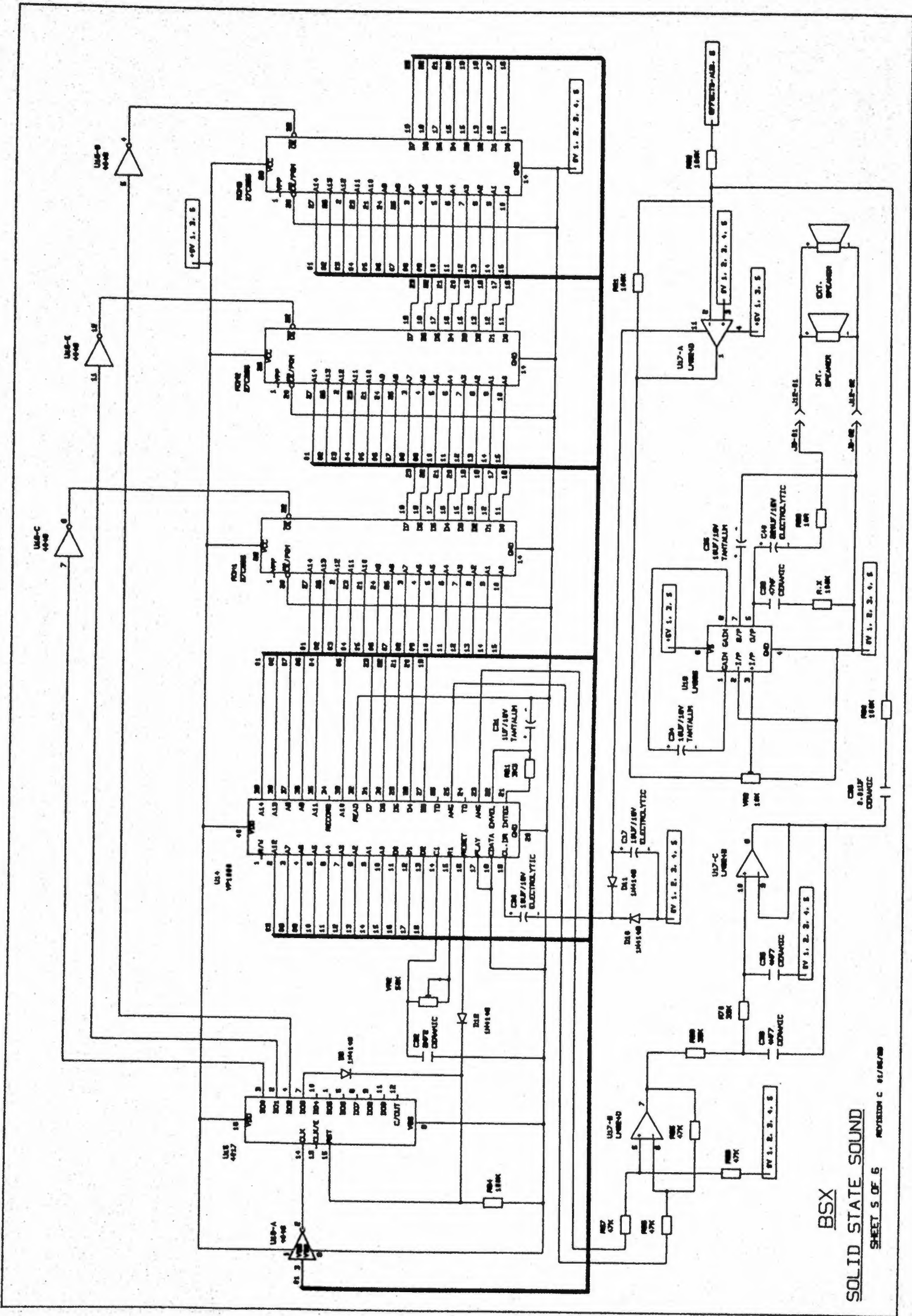

BSX
 SOLID STATE SOUND
 SHEET 5 OF 6 REVISION C 01/06/80

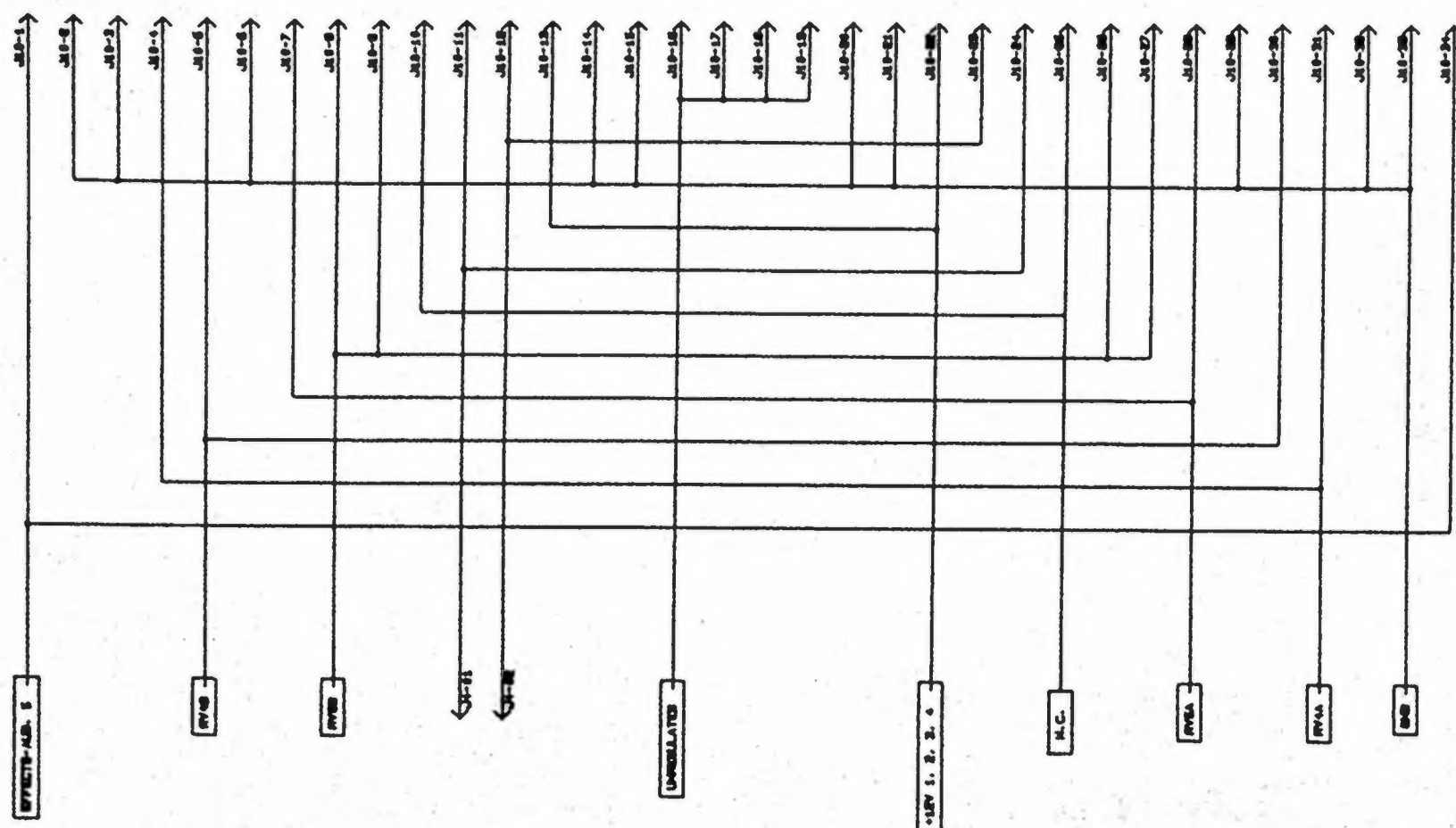

BSX
CONTROL BOARD CONNECTOR

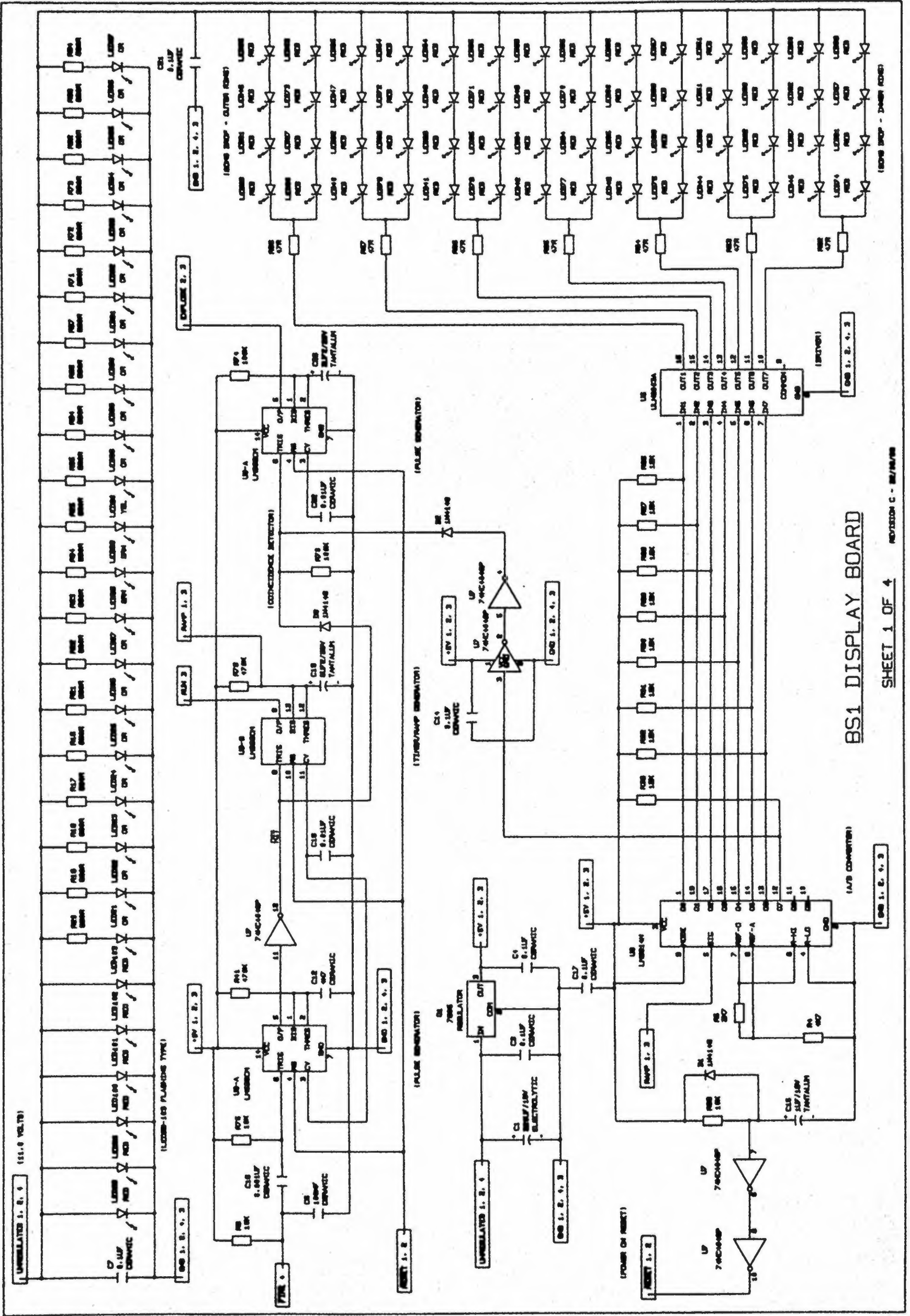

BS1 DISPLAY BOARD

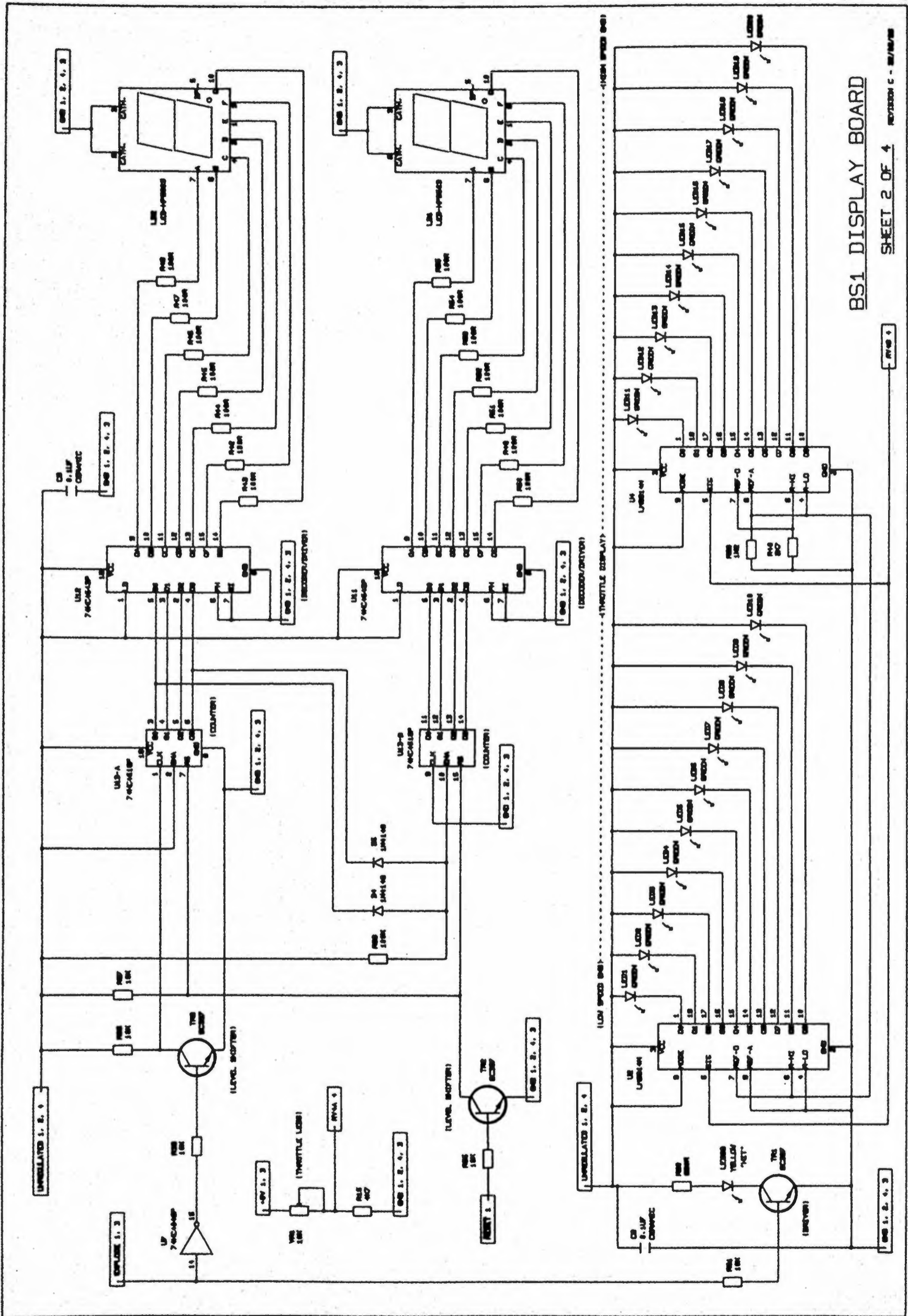

BS1 DISPLAY BOARD

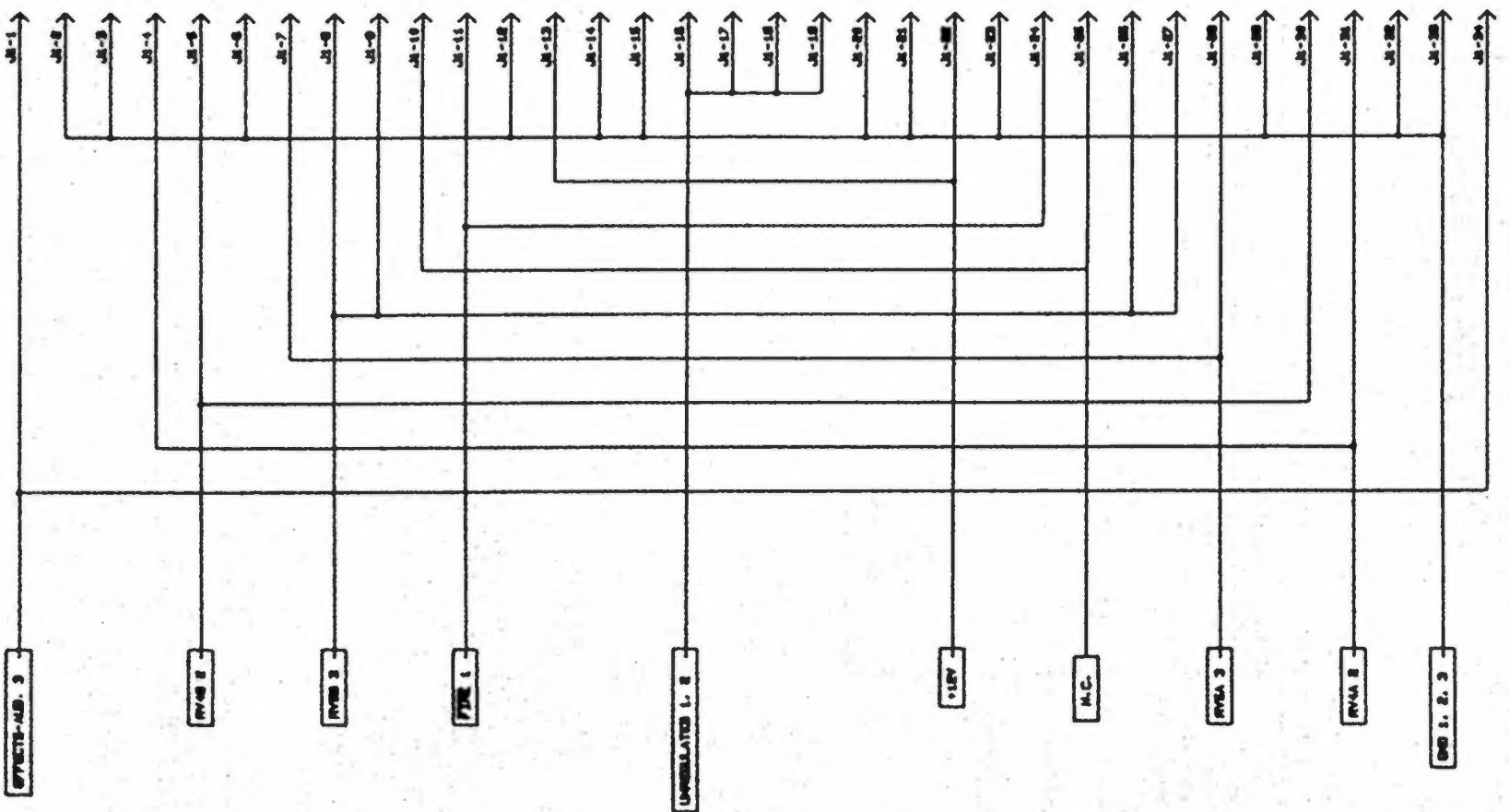

BS1 DISPLAY CONNECTOR

SHEET 4 OF 4 REVISION C - 02/10/88

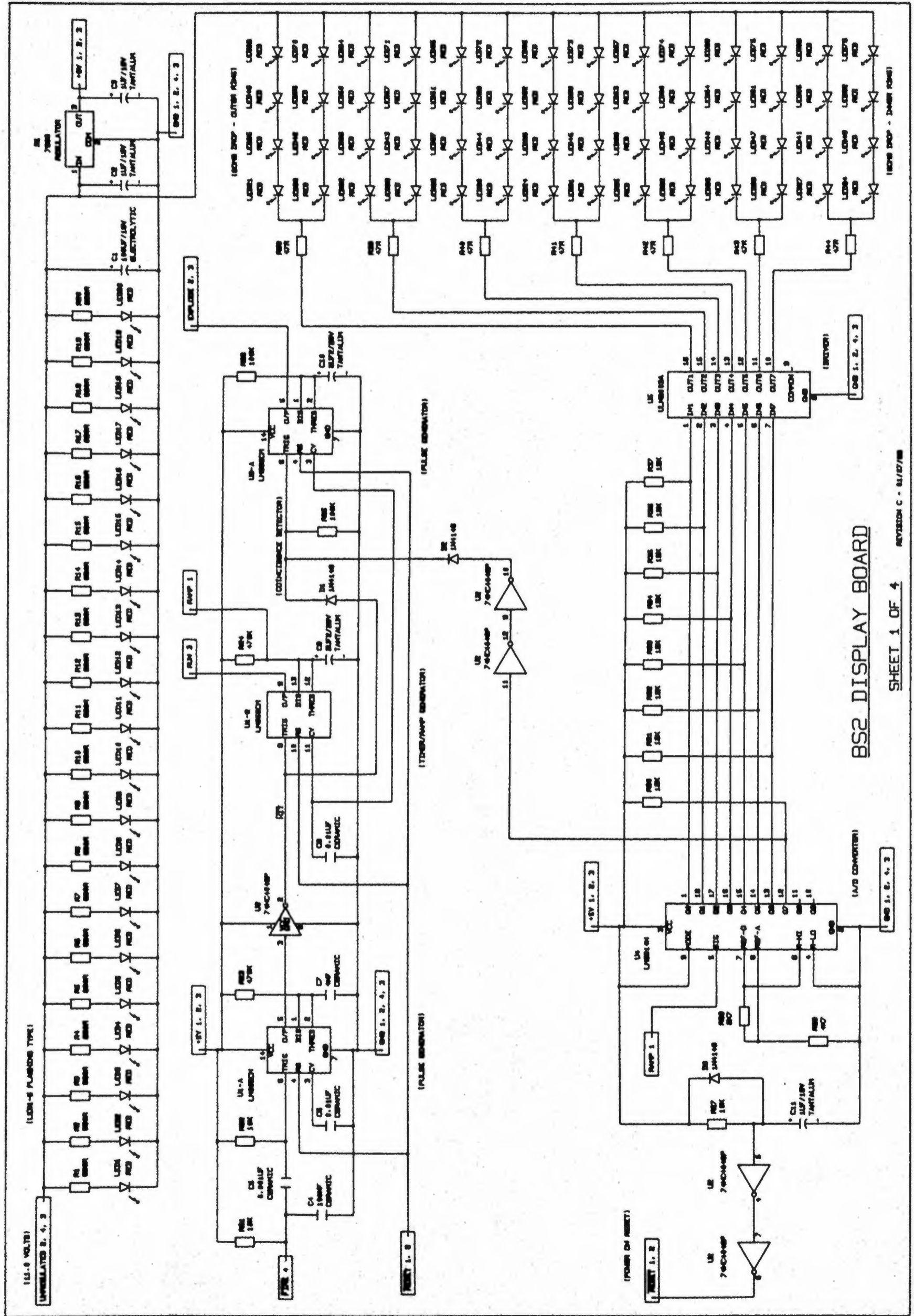

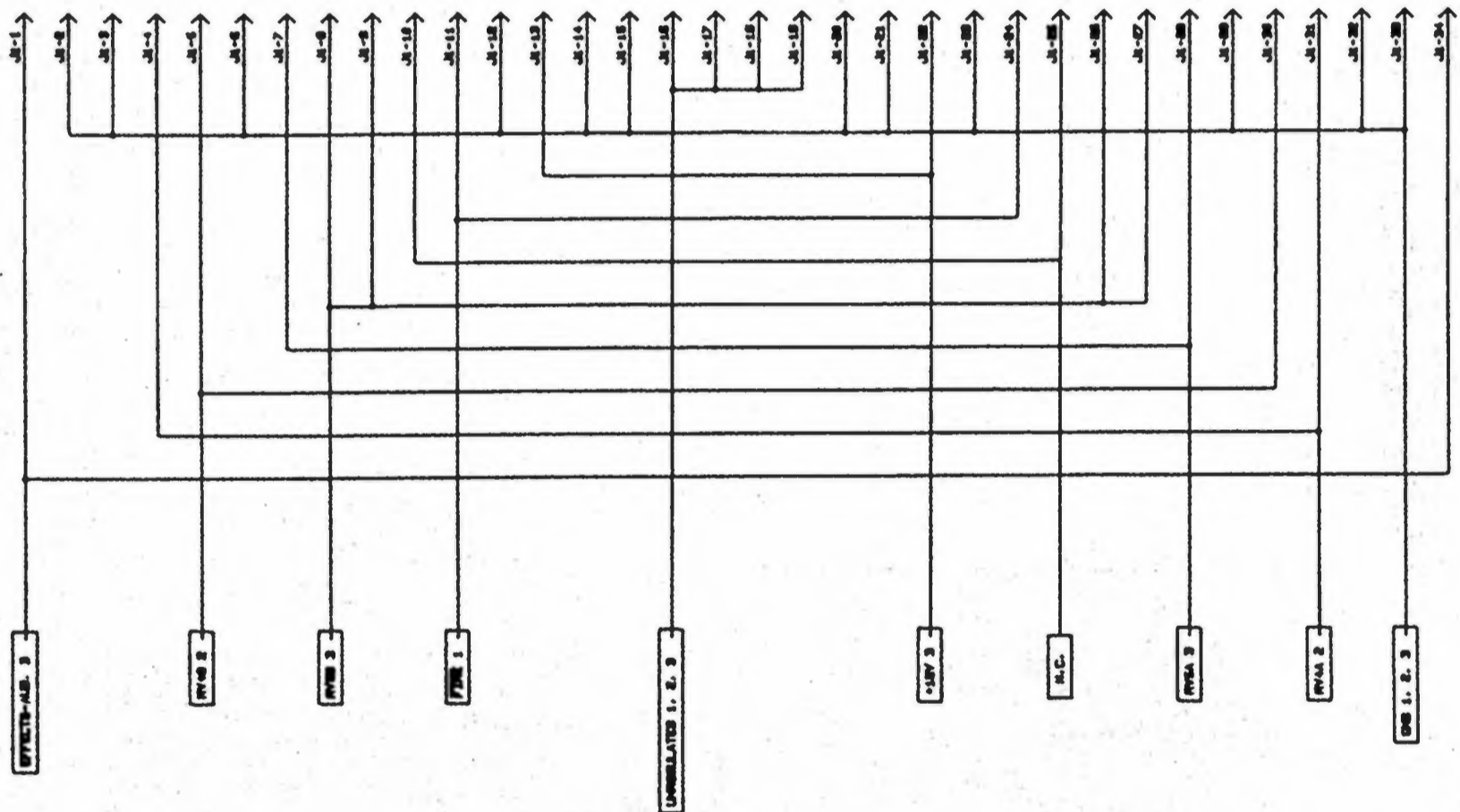

BS2 DISPLAY CONNECTOR

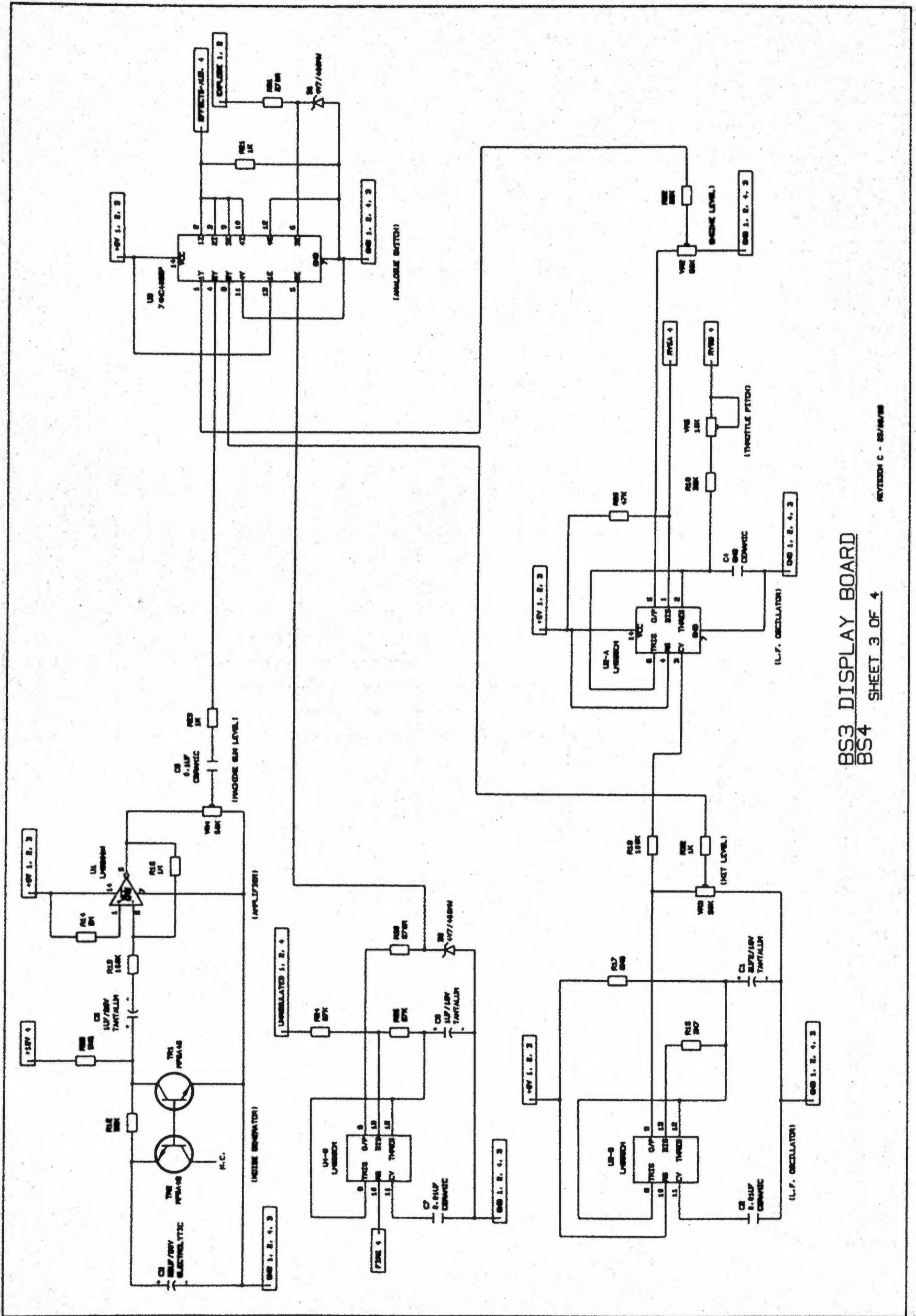

BS3 DISPLAY BOARD
BS4

SHEET 3 OF 4

REVISION C - 05/16/78

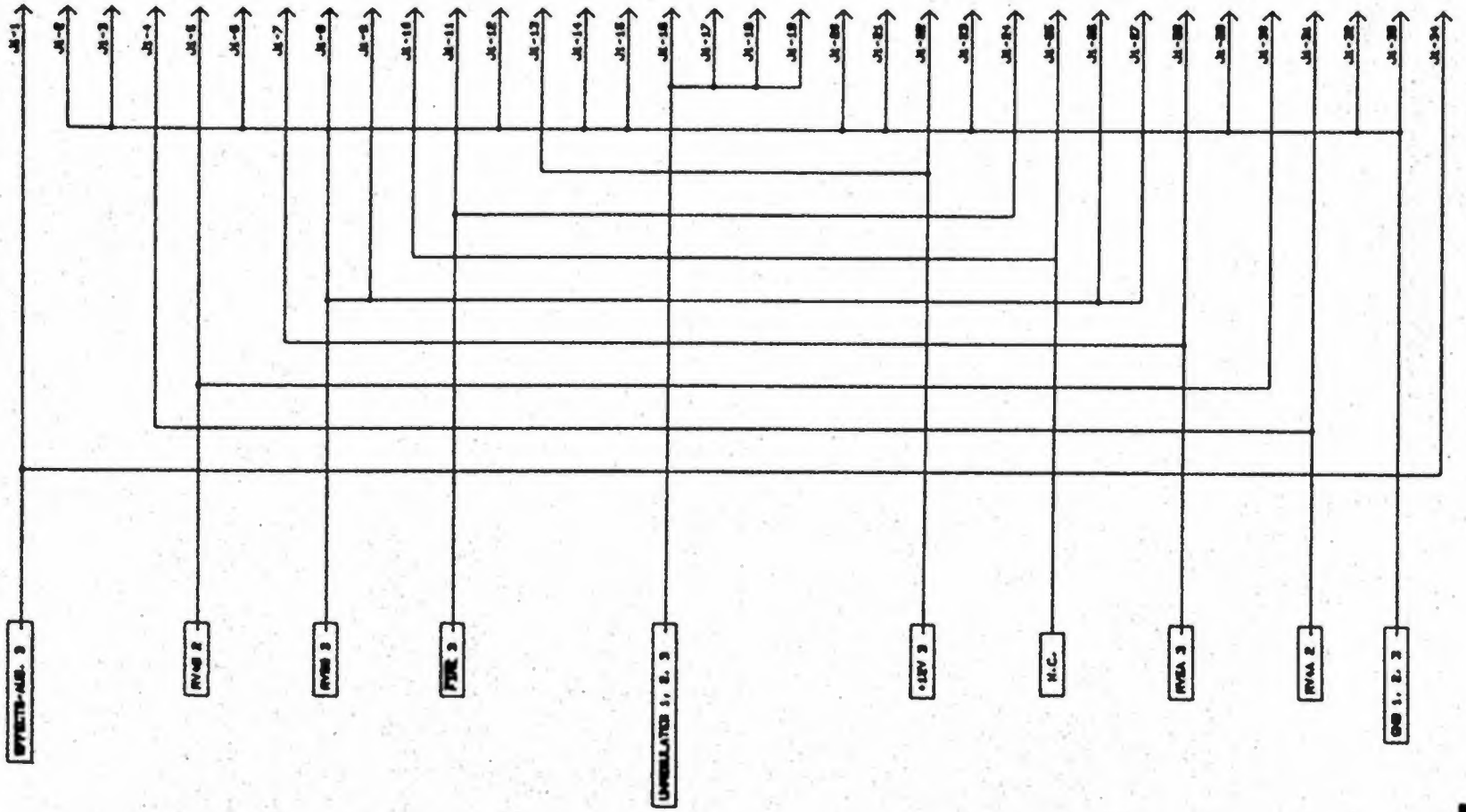

BS3 DISPLAY CONNECTOR

BS4 SHEET 4 OF 4

REVISION C - 02/04/00

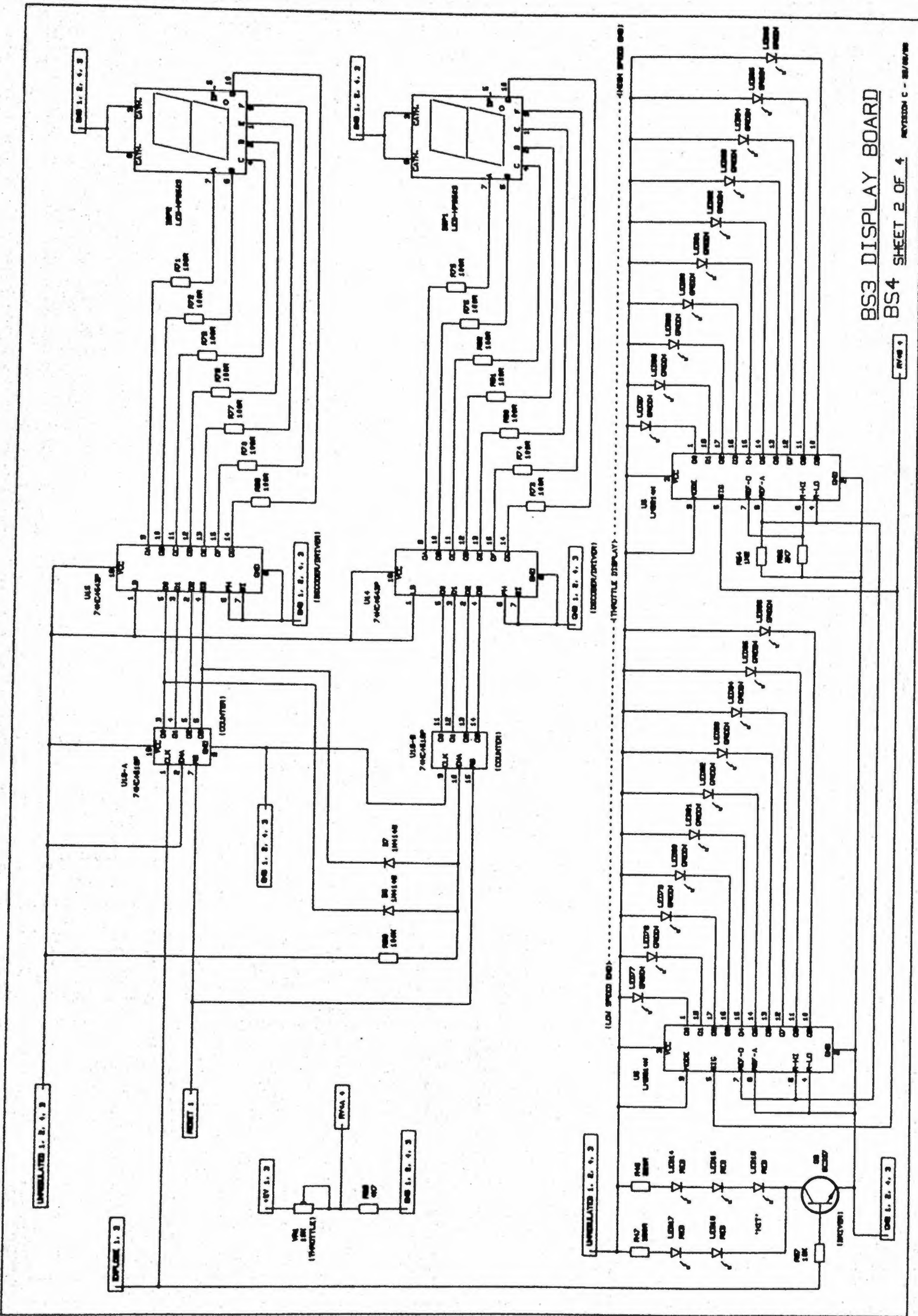

BS3 DISPLAY BOARD
 BS4 SHEET 2 OF 4

REVISION C - 08/08/88

REV 0

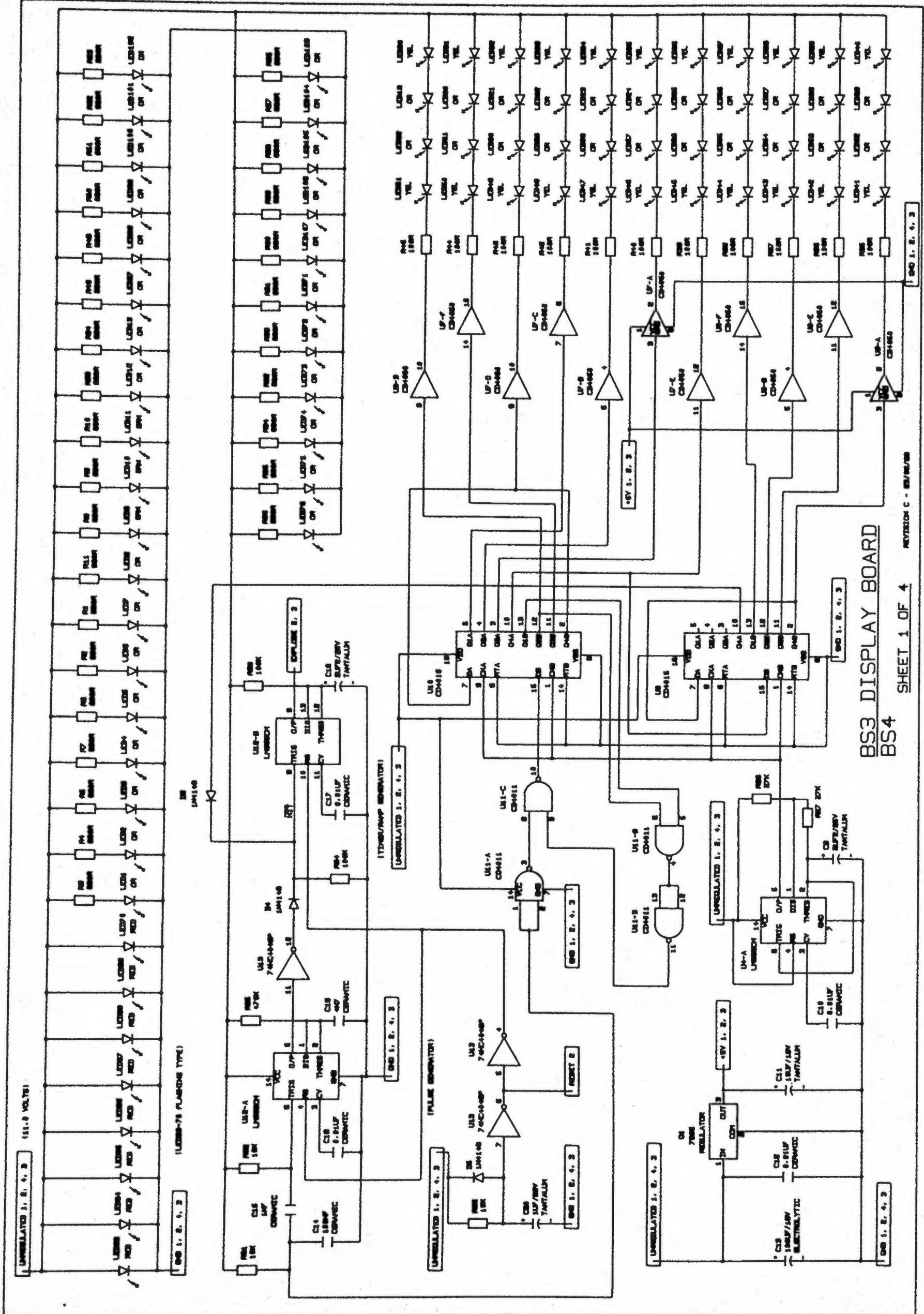

BS3 DISPLAY BOARD
BS4

SHEET 1 OF 4 REVISION C - 03/80/MS