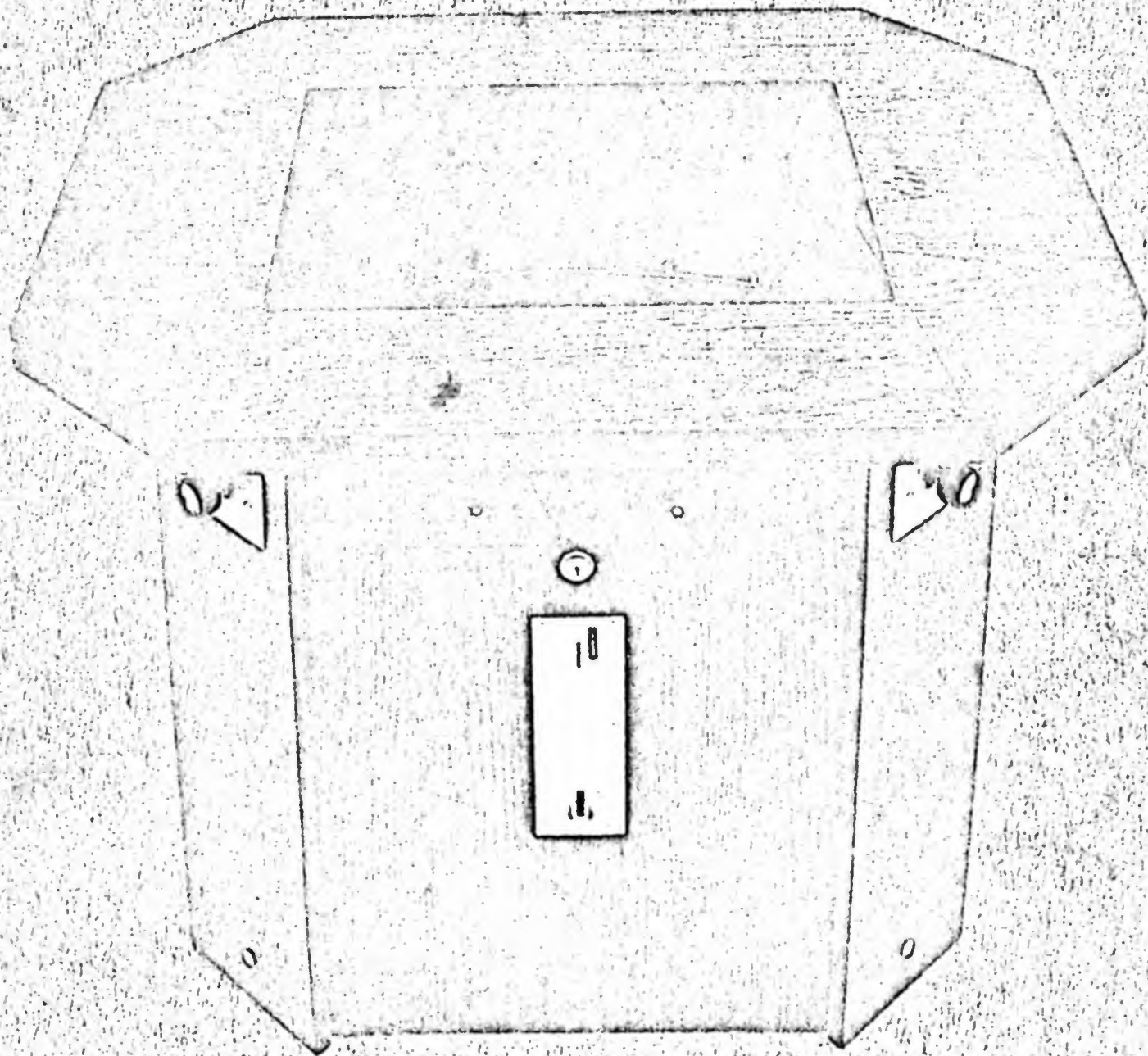


# MODEL 474

## COCKTAIL TABLE VIDEO GAME

"DIGITAL" CHALLENGER



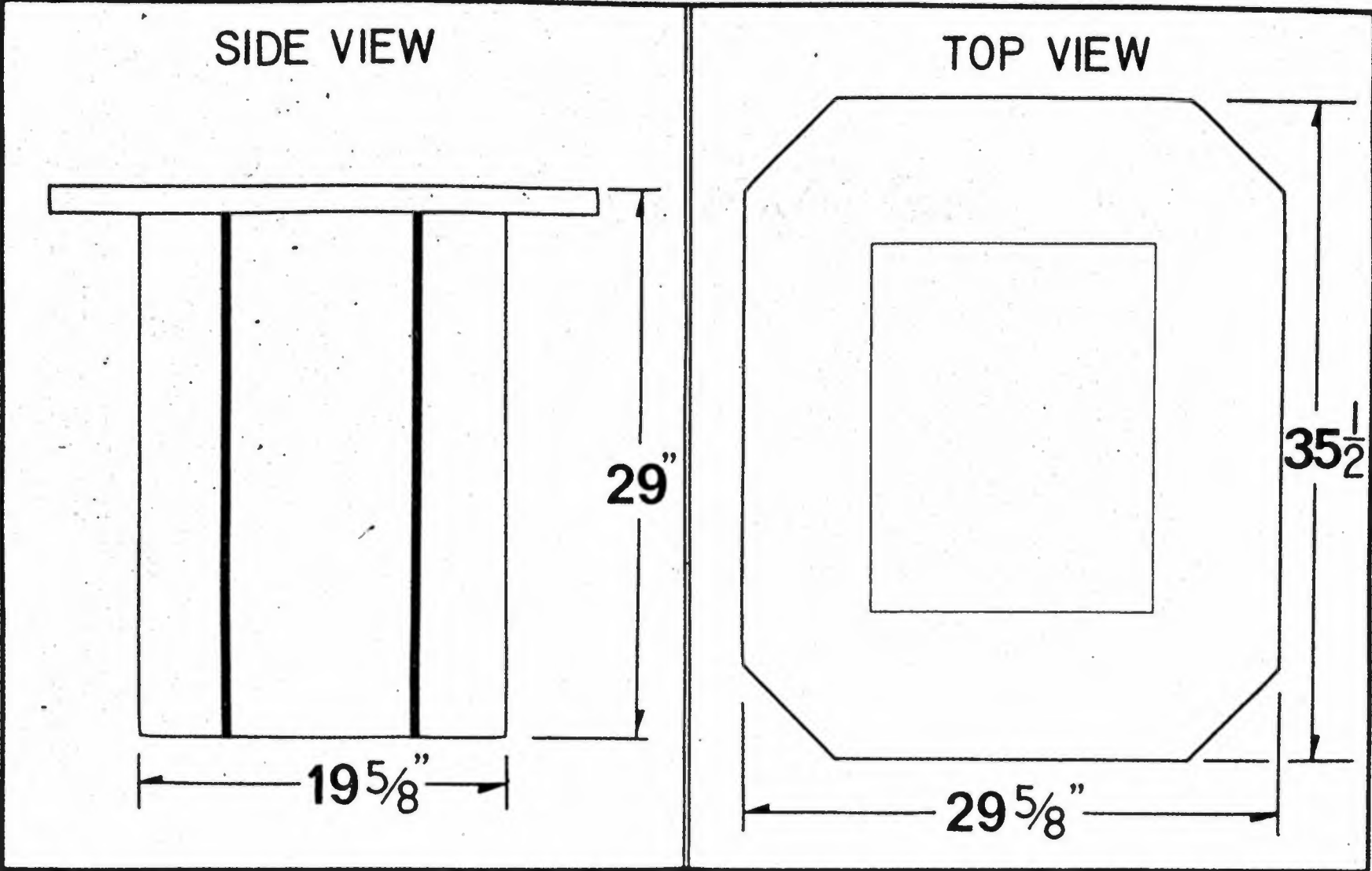
- 1-2-4 PLAYER
- FREE GAME OPTION
- ONE PIECE LOGIC BOARD
- 19" SOLID STATE MONITOR
- PLAY METER (Coin Meter)

- FULL FACTORY WARRANTY
- ILLUMINATED COIN SWITCH
- SIDE MOUNTED KNOBS
- \$500 LOCKING COIN VAULT
- 25/50 CENT PLAY

**Digital Games  
Incorporated**



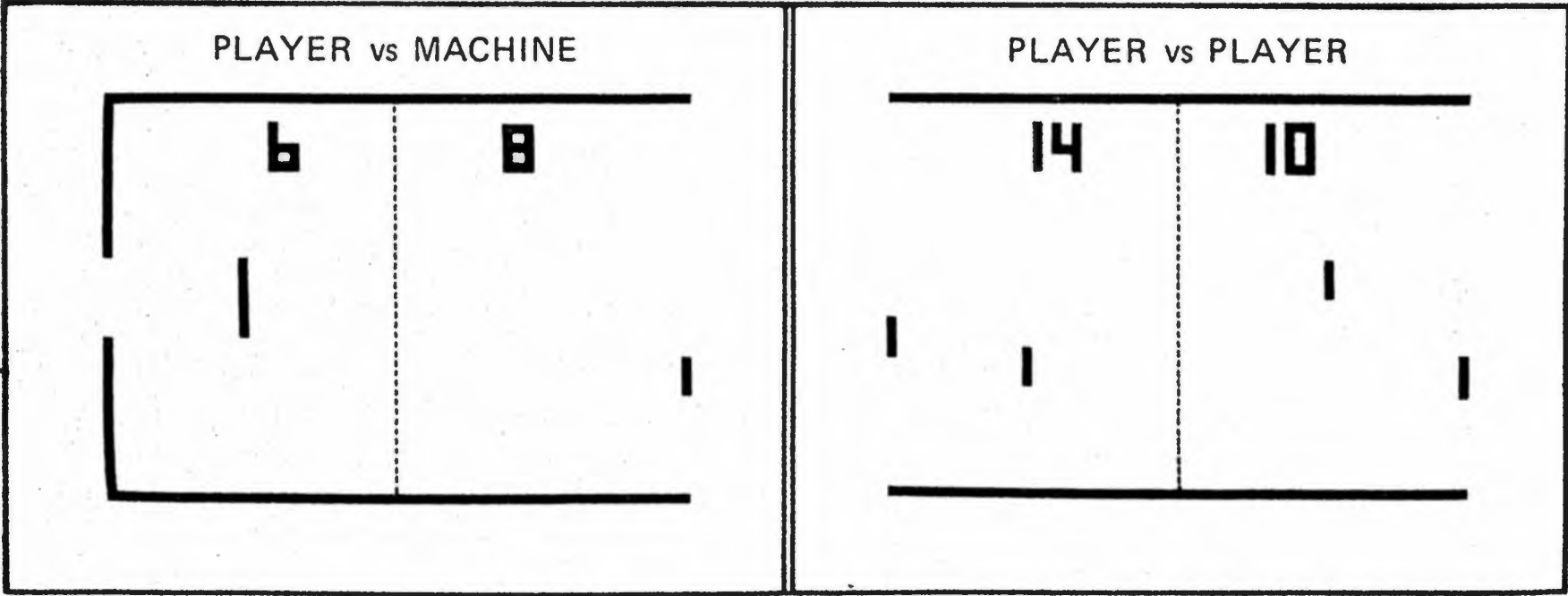
For Further Information Contact:  
DIGITAL GAMES, INC.  
545 Terrace Drive, San Dimas, Ca. 91773



POWER REQUIREMENTS:  
115 VAC 60 CYCLE SINGLE PHASE 100 WATTS  
3 WIRE PLUG

SHIPPING WEIGHT: 160 LBS.  
SHIPPING SIZE: 30" x 36" x 30"

**PLAY FIELD - PLAYER OPTION**



DISTRIBUTED BY:

## TABLE OF CONTENTS

	Page
I. Introduction	1
What the Heck Is a Video Game?	1
What To Do When You Receive Your New Video Game	1
Cleaning and Maintenance	2
Vandalism	2
II. Theory of Operation	2
Operator's Option	3
III. Integrated Circuit Information	3
Socket Mounted I.C.'s	3
Finding an I.C.	3
I.C. Diagram figure I	3
I.C. Descriptions	4
IV. Circuit Descriptions	4
Oscillator and Sync Circuit	4
Ball Generator	5
Paddle Generator	5
Score Generator	5
Executive Circuit	6
Horizontal and Vertical Decoder	6
Audio Circuit	7
V. Schematics	
474 Schematic figure II	
474 Cable Harness figure III	
Oscillator and Sync Circuit figure IV	
Ball Generator figure V	
Paddle Generator figure VI	
Score Generator figure VII	
Executive Circuit figure VIII	
Horizontal and Vertical Decode figure IX	
Audio Circuit figure X	
Wave Forms and Sync Signals XI	
VI. Troubleshooting	7
General Troubleshooting	7
Troubleshooting	8
I.C. Locations	8
Troubleshooting Guide	10
Oscillator and Sync Circuit	10
Ball Generator	10
Paddle Generator	10
Score Generator	10
Executive Circuit	10
Horizontal and Vertical Decoder	9
Audio Circuit	10

## WHAT THE HECK IS THIS HANDBOOK ABOUT?

This handbook is meant to tell you why Digital Games, Inc. is alive and well in San Dimas, California. It would be unwise to divulge our many secrets of success but we will reveal one. It is our concern about the product that is sold to our customers. Hopefully, this handbook will reflect DGI's desire to see its customers achieve the most efficient operation out of their machines.

There will be sections dealing with the "brain" of these machines, the logic board, and how to perform "brain surgery" if something should go wrong.

The monitor, or television, will be given attention as to its workings. It is suggested that service of these are best left to a trained technician. Monitors can store up large amounts of voltage and it would sadden us greatly if someone got a charge out of our game without playing it.

We will even endeavor to tell you everything you've always wanted to know about integrated circuits but didn't care about until you got a video game.

So that you will know exactly what your machine is supposed to do, a colorfully written section on its playing procedure is also included. If your machine doesn't do what is described, you will know that something is wrong. If your machine does more than what is described, please tell us; you may have discovered a new game.

Keep in mind that the repair sections of this booklet will not train you for a PhD in video game maintenance. If you are relatively inexperienced with electronics, please do not attempt to repair your logic board armed only with the information presented in this booklet. However, if you have had some background in this area, by all means go after that problem board. The information is presented somewhat simply in an attempt to reduce the number of confused operators. Even the learned repairman may be enlightened by a quick review of basics.

The preceding paragraphs have attempted to capsulize the purpose of this booklet. If we are successful, you will be entertained, informed, and excited all in one painless treatment. At this point it would be appropriate to close with our company slogan. Unfortunately, we don't have a company slogan.

## WHAT THE HECK IS A VIDEO GAME?

First let's clarify what video games are not. They are not a necessity of life and man could probably manage without them. He could continue to use computer technology as a means of solving calculus problems, keeping a statistical tally of the number of chicken farms in Iowa, and other vital scientific functions. Video games can do none of these things. In fact, even though the game is transmitted onto what is basically a television screen, you cannot receive television broadcasts on it. So what it all boils down to is that video games are sheer entertainment devices, extremely clever and somewhat complicated . . . and so much fun we can hardly stand it.

\*"All right," you may say, "so they're fun. Are they financially rewarding?" It seems that most people are attracted to video games. Their attention is caught by (using the Knockout game as an example) a ball bouncing about in a random pattern and they are intrigued by what electronic mysteries are to be discovered. All it takes is a mere pittance of change; a relatively paltry sum for the delights that await them. Ah ha! But it doesn't stop there. Once they have gotten a taste of video gaming, it becomes necessary to try it again since they now believe they understand how to play it. You can expect an occasional group of interested spectators to crowd around the player/players and await their turn or just cheer and groan the player's efforts.

## WHAT TO DO WHEN YOUR NEW VIDEO GAME ARRIVES

Unforeseen mishaps may have happened to your game on its long journey from our factory to you. We realize that the temptation to hastily plug in the machine and try your video game expertise is overwhelming. However, abstain from the urge and take a long, leisurely look at your machine.

Damage to the cabinet is bound to be the most obvious place shipping damage would be incurred. With your eagle-eye, inspect the interior and exterior for cracked, broken, or warped parts. It might be appropriate to put on your white gloves now. Dangling wires without a proper home and foreign objects inside the cabinet can wreak havoc. While you're admiring our orderly arrangement and quality workmanship in there, check the connectors to the coin switch, TV monitor, interlock switch, and potentiometers. Is everything in order? Good. Now it is very important that you make sure that the connectors that lead to the PCB board are plugged in tightly. These are usually troublemakers.

At long last you can plug the machine in and see if the image on the screen is crisp, clear, and generally pleasing to the eye. Open the door at the back again and . . . surprise! . . . the power is cut off. Everything is still rosey because this only means that the interlock switch (your personal guard against electrical shocks) is functioning properly. If the machine must be on while the door is open, simply pull the white actuator shaft out and proceed with extreme caution.

With the machine on, gather together some coins and begin inserting them in the coin acceptor. Check to see if you receive a game each time a coin is inserted and that the coin counter is working. Give the coin rejector a number of tries too. You may find this clever device so entertaining that some time may be spent marvelling at it.

One last trivial thing before we move into actually playing the game. Check to see if the doors open and close without a struggle and that the locks are doing their job.

## CLEANING AND MAINTENANCE

You will find that DGI's games are rather devoid of any need for continual maintenance. However, machines do get dirty and a tidy-looking game will attract more customers. When cleaning the cabinet don't use harsh detergents but give it a few wipes with a damp cloth and occasionally apply furniture polish to give it a sparkling look. The plexiglass screen may be cleaned with any number of non-abrasive cleansers. On the cocktail table models, you can add a touch of class by providing ash trays and coasters.

The mechanical parts of the coin acceptor would be all the better if the operator could spray some sort of silicone lubricant on them every three months or so. Do not get too carried away in lubricating as to lube the potentiometer shafts. This is a no-no. It may be necessary to occasionally adjust the TV monitor. Do this only when the image is distorted or if a brightness or contrast adjustment needs to be made.

## VANDALISM

The sad facts of life are that people enjoy being destructive as well as constructive. Some may choose to exercise their lack of self-control on our machines. That results in vandalism. The best way to avoid vandalism is to select a location for your machine carefully. Avoid unusually run-down areas. Even though a complete personality test is impractical, try to find a somewhat virtuous operator. If possible, arrange to have the machine placed in an easily viewed spot. Generally, most people respect another person's property but it doesn't hurt to exercise a little care in the placement of your machine. Note: If you notice a large man wearing a black overcoat, white tennis shoes and a crazed expression lumber towards your machine armed with a baseball bat . . . be suspicious.

474

## THEORY OF OPERATION

By now you have probably twisted knobs, pushed buttons and opened doors in a vain attempt to figure out the playing procedure of this machine. Initially, the power cord must be plugged into a three-pronged grounded outlet. Without this first step the game is no fun to play at all. Be patient for a couple of minutes as the machine warms up. When the picture appears on the screen it will be in the ever-popular "attract" mode. In this state, one ball can be seen silently hurling itself against the walls and returning from empty space. This is indeed entertaining, watching the ball traverse the playing area. Back and forth, up and down, over and across . . . but there is more to this game. If you wish, while your customers are in a mild state of hypnosis from the ball's movement, you may quietly repeat, "You will put money in this game. You will put money in this game." It might be worth a try.

Video games thrive on money and ours will voraciously gobble down the coin that is required to move it into the "ready" mode. At this point, the ball runs off and hides, an occasional deep-throated buzz can be heard and the paddles appear. It is now necessary to choose the game you wish to play. When the coin is dropped, the machine will randomly be in either of the two games. Let us suppose that you wish to play against an opponent. First you would need an opponent. Next you would press the player vs player button. This results in two paddles; one each on the left and the right. By turning the knob (potentiometer for the electrically-minded) you have complete control of where to hit the ball. They are capable of moving vertically across the screen and provide the player with a variety of shotmaking possibilities. The top four lines hit the ball up, the bottom four lines hit the ball down and the middle eight lines hit the ball straight. The bottom four lines are endowed with a special ability. After a few hits, the ball will suddenly speed up and add that unexpected offensive move. However, you may have created a monster because once the ball speeds up, only a miss will slow it down.

To coax the ball out of its hiding place, press the "start" button and the game will begin. The ball makes its surprise appearance by serving to either one of the competitors. The buzzing ceases and the ball charges headlong to reach the empty space behind the paddle. The player will attempt to block its escape by positioning his paddle in front of it.

The game is in progress. Each player's muscles are tensed as the ball is bounced rapidly across the net. Accompanying the ball's rebound off the paddles is an impressive electronic "ponk" and a similar sound is heard as the ball strikes the walls. Neither person admits that they will miss and a stubborn determination sets in. This cannot continue for much longer. Sooner or later one will yield to the pressure and the ball will get by them. After the ball disappears into the black void, a buzz is heard and the score is flashed on the screen for all the world to see. As an extra insult, the machine utters another buzz. Very rude. The score then vanishes and the ball is served to the unfortunate player who just missed.

Now let us say that the game has progressed so that only one point is necessary for a player to win. Fatigue is etched in their faces and beads of perspiration have formed on the losing player's forehead. At last the fateful moment arrives. The ball is missed; the final point has been scored. Instantly, the paddles disintegrate, the sound stops and the ball resumes its pointless roaming of the open spaces. One reminder of the game lingers on; the score is still displayed. Hopefully, the player who lost will want to remove this electronic monument to his defeat. If so, another coin, please.

The Challenger game is not confined to two people. If you know three other people (and have two coins) a four-player version can be played. After the money has been inserted, press the player vs player button. In addition to the two-player paddles will appear their twin brothers, located a little ways in front. Each team controls their own paddle and teamwork takes on a new meaning. A bit of razzle-dazzle can be employed by bouncing the ball off the back paddle and through your partner's front paddle. As the ball emerges from the front of his paddle, the ball will speed up and, depending on where the ball entered his paddle, careen off at an angle. All is fair in love and video games.

Are you all alone tonight? No one to challenge in Challenger? Is that what's bugging you, buddy? Then step right up, deposit a coin and press the player vs machine button. Right before your very eyes a wall running the full length of the screen will appear at one end and that familiar paddle at the other. A small space is missing from the center of the wall and it is your mission to bounce the ball through that opening. To complicate matters somewhat, a small barrier stands guard a short distance away from the hole. The player is required to call upon his skills to carom the ball off the walls and through the opening. It is even possible to score a point without any rebound. At the same time the player is trying to accomplish this, he must be alert to return a misguided shot that bounces back towards him.

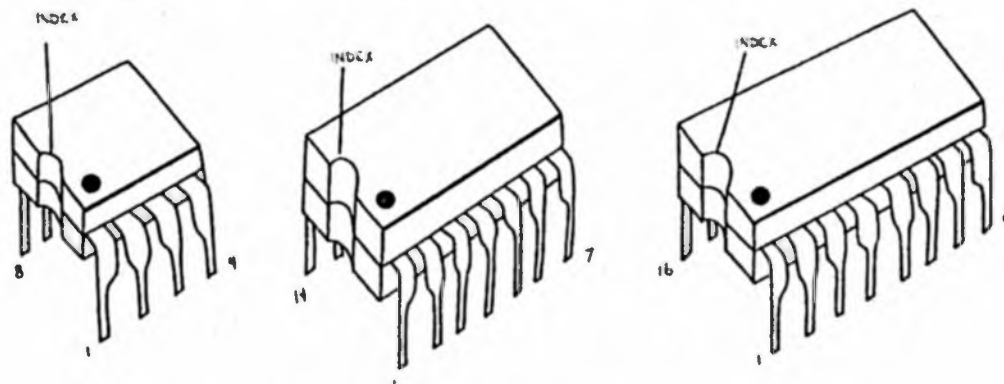
If you manage to beat the machine, you are rewarded with a free game. If this occurs, a tiny light will illuminate to signify your accomplishment and the game will reset to the "ready" mode, waiting for you to press the "start" button. There is no deafening applause or joyous music. The machine hates to be beaten.

Taking into account the difficulty of beating the machine, there is another way that you can escape defeat. For two coins, two players can join together and battle the computerized foe. This makes winning a free game much easier and total frustration can be avoided. With the two individually controlled paddles, more angles to the hole are available. The dueling duo can also share the burden if they lose.

474

### OPERATOR'S OPTION

To give a free game or not to give a free game; that is your option. Whether the reason 'tis a law prohibiting them or just because you are basically a mean person, must give us pause. The choice is in your hands. Deftly lift pins 9 and 10 on 7H (7400) and the deed is done. Henceforth, the player will be unable to earn a free game.



### SOCKET-MOUNTED I.C.'s

There is an extra expense involved in manufacturing our PC boards with sockets for each I.C. DGI feels that they more than make up for its higher production price in the long run. Anyone who has removed an I.C. from a PC board that has been soldered in will attest to the fact that it is a pain in the amps. It is a time consuming and a difficult task. The electrical technician would equate it with latrine duty in the armed forces.

Once your board goes out of warranty, you can no longer send it back to DGI for a free repair so socket-mounted I.C.'s are a blessing to the operator/repairman. They are rather simple to replace, especially using the I.C. insertion tool and if you find that the I.C. you just took out was not bad, it can usually be used again.

Problems associated with an I.C. loosely fitted into a socket are easily eliminated if the operator will pause a minute before reinserting his board into the machine to visually check for an insecure (not emotionally) I.C.

## FINDING AN I.C.

The I.C.'s are labeled throughout the manual according to their actual grid number on the board. Pin numbers are listed according to their actual position on the I.C. For example: 2G pin 3. Look for the number "2" at the bottom of the board and the letter "G" on the side. Where the two numbers come together is the spot you've been looking for. Now that you've found the I.C., look at the diagram below and count the pins starting at pin 1, 1, 2, 3, now you have found 2G pin 3.

When replacing I.C.'s make certain that they are right side up. If the pin locating key points toward the letters, everything is fine. If not, adverse effects will result. One final word, please . . . please use the I.C. insertion tool to replace I.C.'s.

474

555 —Timer

7400 —Quad 2-Input NAND Gate

7402 —Quad 2-Input NOR Gate

7410 —Triple 3-Input NAND Gate

7412 —Triple 3-Input NAND Gate (Open Collector)

7420 (0024)—Dual 4-Input NAND Gate

7425 —Dual 4-Input NOR Gate w/strobe

7432 —Quad 2-Input OR Gate

7442 —BCD to Decimal Decoder/Driver

7448 —BCD to 7-Segment Decoder

7473 —Dual JK M/S Flip-Flop

7474 —Dual D Flip-Flop

7476 —Dual JK M/S Flip-Flop

7486 —Quad Exclusive OR Gate

7490 —Decoder Counter

74193—Up/Down Binary Counter

74195—4-Bit Universal Shift Register

9316 —4-Bit Binary Counter

9321 —Dual 1-of-4 Decoder

9322 —Quad 2-Input Multiplexer

## OSCILLATOR AND SYNC CIRCUIT

This circuit consists of a crystal controlled oscillator, buffer driver 1A pins 1,2,3,4,5 and 6, two horizontal counters 1B and 1C, two vertical counters 1F and 1G, a dual JK master slave flip-flop and nand gates 1A and 1D.

The crystal used in the oscillator is a 5 megacycle, low impedance, series resonant type. The output of the oscillator is sent to the buffer driver 1A pin 4 and sent to the horizontal counters 1B,1C and 1E. These are synchronous four-bit presettable counters capable of counting to 512 H. Since all we need is 317 horizontal clock pulses we preset the counters to 195 H. When the counters are enabled pin 12 of 1E will go high at the count of 256 H. The counters are preset through 1D and continue to count to 317 H. Pin 15 goes high and pin 12 is already high so the output of 1D pin 11 resets the horizontal counter for the new count.

Clocking for the vertical sync is generated from 1D pin 11. This pulse is inverted through 1D pin 6 thus enabling the vertical counters. The vertical counters work in the same way as the horizontal except they only count to 262 V. At that time 1E pins 5 and 9 go high resetting both vertical counters.

## BALL GENERATOR

The ball generator consists of both horizontal and vertical information.

The horizontal circuit is made up of two up-down counters (74193) 2A and 2E tied in series. Its outputs are fed into comparitors 2B and 2D. The open inputs of the comparitors are connected to the Q outputs of the horizontal sync circuit 1B pins 11,12,13,14 and 1C pins 11,12,13, and 14.

The vertical circuit is the same as the horizontal except the information is received from 1G and 1H, the vertical part of the sync circuit.

When the numbers in the horizontal sync (74161) and horizontal ball counters (74193) are the same, all outputs in 2B and 2D will be low and 2C then goes high. The high pulse is fed through a nand gate 3D pins 12 and 13 then sends a negative pulse to the shift register 3F pins 2 and 3. The shift register puts out a pulse three clocks wide. This pulse is fed through nand gates 3D pins 9 and 10, 3E pins 1,2,4 and 5 and 4D pins 9 and 11. This tells us the ball is now three clocks wide. The vertical information comes through 4D pins 10 and 11. This tells us the ball is four lines tall.

Ball direction and speed consists of a left-right latch 3A pins 8 and 11; the up-down latch 5E pins 8 and 12 and stop-go latch 5F pins 6 and 12. All above latches are controlled by the paddle circuit or top and bottom wall.

Horizontal ball speed is regulated by the lower middle lines of each paddle. When the ball and paddle coincide a pulse is sent to latch 6C pin 9 which in turn sends a pulse to pin 1 of 6A. 6A is a dual JK flip-flop (7473).

The vertical ball direction is associated with the top and bottom wall. The top wall 6E pin 9 and bottom wall 6E pin 13 combined with the ball 4D pin 6 tells the ball that anytime it and either wall coincide, reverse direction. For example: If the ball and the top wall coincide when the ball is at fast speed 6E pin 8 goes high, slowing the vertical speed, 5E pin 8 goes high enabling 4E pin 11 and tells the ball to move in a downward direction. At this time 1H pin 5 is enabled, generating sound from the top wall.

## PADDLE GENERATOR

The paddles are controlled by four rotary potentiometers mounted on the sides of the machine and used by the players to position the paddles appearing on the screen.

The paddle circuit is made up of four 555 timers used as one-shots, four 74161 counters 7A,7C,7E, and 7G: counter enables which are nor gates 8F pins 10 and 13; nand gates 8G pins 8 and 11 also 8D pins 8 and 11 used to combine horizontal and vertical information; nor gates 8B pins 1 and 4 and 8F pins 1 and 4 used as inverters; nand gates 8D pins 3 and 6 and 8G pins 3 and 6 used as ball and paddle coincidence and enables the one of four decoders 7B and 7F; 7B pins 5 and 11 and 7F pins 4 and 12 tell the ball to move up. 7B pins 5 and 11 and 7F pins 5 and 11 tell the ball to move down. Nor gates 4K and 3M regulate the player vs. machine mode.

1E pin 9 is the vertical pulse that triggers pin 2 on each 555 once every vertical frame (16 ms.). A .47 capacitor is charged by pins 5 and 6 on the 555. The rate of charge is determined by the position of the paddles on the screen. Pin 4 is the bottom limit trigger. This says if a paddle does not appear yet on the screen, appear now. Pin 3 is the output sent to nor gate 8F pin 9, its output on pin 10 enables the paddle counter (74161) 7G. When it has counted 16 lines pin 15 goes high disabling 8F and turning the counter off until the next vertical frame when the counter is reset. Nand gate 8G combines horizontal and vertical information through 8F, a nor gate used as an inverter. This is sent on to 8G pin 5 (paddle coincidence). The ball hits the paddle, pin 4 of 8G goes high, pin 5, already high goes low enabling 7F, a one of four decoders which goes up to the left-right latch at 5A pin 13 and reverses the ball direction. The output of 7F divides the paddle into four segments, the outputs tell the ball to go up, go straight, go straight and speed up, go down. All this information is sent to the ball control circuit which gives its commands.

In the player vs. machine mode, nor gates 4K and 3M are used to decode the left wall and paddle.

## SCORE GENERATOR

The score circuit consists of a right score wall 5D pins 3,4, and 5; left score wall 5C pin 13 and 5D pin 11; left score latch 6G pins 8 and 11; ball blanking latch 5H; ball and score blanking 6H pins 3 and 6; score pulse gate 5G pin 4; counters 6J and 6K; score 10 counter 7L; score multiplexer 6L; seven segment decoder 6M; number segment generators 5L, 5K, and 5J; and the 1 gate 7M.

When a player receives a score on the right side 5D pin 3 goes high enabling 5D pin 6 which reverses the ball

direction and enables score latch 6G pin 3, this sends a pulse through nor gate 5G at pin 1 enabling the ball blanking gate 6H at pins 3 and 6 to blank the ball until the next serve. While the ball is blanked the score is disabled by pin 4 at 5G.

Anytime a score pulse is received at 6K (7490) the information is sent to 6L for multiplexing and then transferred to 6M, a seven segment decoder driver. 6M enables the correct segments to be displayed in the score.

Whenever a player reaches a score of 11 or 15, 6L pin sends a pulse to 7J pins 2 and 3 the pulse is inverted through pins 5 and 6 of 7M then goes to pin 11 of 7K, the game over pulse. When the score is set to 15 the game over pulse is sent to pin 12 of 6L and fed through or gate 5M at pin 12.

### EXECUTIVE CIRCUIT

The executive circuit is comprised of a coin input gate located at 8L pin 11; two serve button gates 8L pin 3 6; game over latch 8K pins 8 and 12; four player latch 8J pins 3 and 6; win latch 8H pins 8 and 12; won latch 7H pins 3 and 6; a game over decoder 7J pins 6 and 12; player vs. player latch 8J pin 8 and 8H pin 6; free game light and L.E.D. driver 7H pin 11.

When a coin is deposited into the game all latches are reset to a positive game condition. The serve latch 8L pin 8 sends a pulse to the ball blanking circuit at 5H pin 2, the ball appears on the screen and the game is now in play.

### HORIZONTAL AND VERTICAL DECODER

The decoding circuit consists of two horizontal and two vertical decoders 3B,3C,3J,3H. These decode all the information on the screen through nor gates 4C,5C,4B,5B,3K,3L,4F,4G,4H and 4J; or gate 3L.

The 7442 is a BCD-to-decimal decoder. This device decodes a four-bit BCD number to one of ten outputs. It counts 317 horizontal clocks and 256 vertical clocks. The outputs of each decoder go through all the previously listed gates and decode all horizontal and vertical position such as walls, paddles etc . . .

### GATE LOCATIONS AND FUNCTIONS OF DECODER

#### Horizontal Positions:

- 5C-13 Right Score Wall
- 4C-10 Left Horizontal Blanking
- 4C-13 Right Horizontal Blanking
- 5 5C-4 Net
- 5C-10 E and F Score Segment
- 4B-10 A,D and G Right Number Segment, Left Score
- 4C-1 B and C Number Segments
- 4B-4 F and E Number Segment
- 5B-13 Left Front Paddle
- 4B-1 Right Front Paddle
- 5B-10 Horizontal Right Back Paddle
- 4C-10 Machine Paddles
- 5B-4 Left Number Segments B and C
- 5B-1 Right Number Segments B and C
- 5C-1 Left Score Wall

#### Vertical Positions:

- 4H-10 D Number Segment
- 4J-1 E Number Segment
- 4J-13 G Number Segment
- 3L-8 C and E Number Segment
- 4H-4 B and F Number Segment
- 4H-1 A Number Segment
- 4G-1 Ball Speed Clock
- 3K-10 Machine Back Wall
- 3K-10 Machine Paddle
- 4H-13 Top Wall
- 4G-13 Ball Speed Clock
- 4F-1 Top Limit Trigger
- 4G-4 Bottom Limit Trigger
- 4G-10 Bottom Wall

## **AUDIO CIRCUIT**

This circuit consists of three enable latches 1K pins 3,6,8 and 11 and 1L pins 8 and 11. Their outputs feed the sound gates 1H pins 1,9, and 12. The open inputs of 1H pin 2,10 and 13 are different frequencies received from the vertical part of the sync circuit. The lowest frequency being 1G pin 11 and the highest 1F pin 12.

The audio output is 1J pin 8. Its output pulse is sent to the sound counter 2L (7490) which gives us the length of sound. The sound counter's output at pin 11 is sent to 1L pins 4 and 5 (used as an inverter) and resets all latches for the next command.

## **GENERAL TROUBLESHOOTING APPROACH**

Troubleshooting one of these mysterious printed circuit boards can be a nightmare for someone who is unfamiliar with the way they work. It might help to remember that these boards are also called "logic boards". Unlike many people, the boards work strictly on the principal of logic. If an electrical stimulus is given to one area, it will cause another event to take place, and then another and so forth. Each section of the board is assigned its own special responsibilities. Suppose that the sound system contracts laryngitis. To cure this you would look among the sound circuit and, using the successful combination of schematics, test equipment, and a razor-sharp mind, smoke out the problem.

## TROUBLESHOOTING

Let us say that you have a sick printed circuit board (PCB). Before you call on DGI to make a house call or ship the patient back to us, let's go through the concept of troubleshooting. Basically, you have to relate the problems you see or hear to one or more of the circuits of the computer. If you have a scoring problem, look in the scoring circuit. If it's a paddle problem, look in the paddle circuit. If you can't get channel 7, go back to the introduction and read it again. Once you know the problem area, you can use the recommended test equipment and follow the schematics provided to nail down the problem.

LOCATION	TYPE	FUNCTION
1A	7400	Oscillator, Buffer
1B	74161	First Horizontal Counter
1C	74161	Second Horizontal Counter
1O	7400	Preset Collector
1E	7473	Final Horizontal and Vertical Counter
1F	74161	First Vertical Counter
1G	74161	Second Vertical Counter
1H	7400	Sound Gates
1J	7420	Sound Output
1K	7400	Sound Latch
1L	7400	Sound Latch
2A	74193	Horizontal Ball Counter
2B	7486	Horizontal Ball Comparitor
2C	7425	Horizontal Ball Collector
2D	7486	Horizontal Ball Comparitor
2E	74193	Horizontal Ball Counter
2F	74193	Vertical Ball Counter
2G	7486	Vertical Ball Comparitor
2H	7425	Vertical Ball Collector
2J	7486	Vertical Ball Comparitor
2K	74193	Vertical Ball Counter
2L	7490	Sound Counter
3A	7400	Left-Right Latch
3B	7442	Horizontal Decode
3C	7442	Horizontal Decode
3D	7400	Ball Shape
3E	7420	Ball Shape
3F	74195	Ball Shape
3G	74195	Ball Shape
3H	7442	Horizontal Decode
3J	7442	Horizontal Decode
3K	7402	Number Decode
3L	7432	Number Decode
3M	7402	Sync. Mixer
4A	7402	Right-Left Pulse Gate
4B	7402	Horizontal Decode
4C	7402	Horizontal Decode
4D	7410	Ball Combining
4F	7402	Vertical Speed Control
4E	7400	Ball Speed Gate
4G	7402	Vertical Decoding
4H	7402	Vertical Decoding
4J	7402	Vertical Decoding
4K	7402	Paddle Logic
4L	7420	Video Amp.
4M	7474	Sync. & Video Adder

LOCATION	TYPE	FUNCTION
5B	7432	Horizontal Decoding
5C	7402	Horizontal Decoding
5D	7400	Score Pulse
5E	7410	Vertical Speed Control
5F	7410	Vertical Stop-Go Latch
5G	7402	Score Pulse Gate
5H	7476	Ball Blanking Latch
5J	7403	Number Segment Generator
5K	7403	Number Segment Generator
5L	7403	Number Segment Generator
5M	7432	Game Over Decode
6A		
6B	7420	Horizontal Speed Pulse Gate
6C	7402	Speed Pulse Latch
6D	7402	Horizontal No Decode
6E	7400	Vertical Ball Pulse Gate
6F	7400	Vertical Ball Pulse Gate
6G	7400	Right & Left Score Latch
6H	7400	Ball Blanking Gate
6J	7400	Left Counter
6K	7490	Right Counter
6L	74157	Score Multiplexer
6M	7448	Seven Segment Decoder
7A	74161	Left-Back Paddle Counter
7B	9321	Left Paddle Decoder
7C	74161	Left-Front Paddle Counter
7D	7400	Paddle Pulse Gate
7E	74161	Right-Front Paddle Counter
7F	9321	Right Paddle Decoder
7G	74161	Right-Back Paddle Counter
7H	7400	Win Game Latch
7J	7410	Game Over Decoder
7K	7402	Game Over Pulse Gate
7M	7402	Score 10 Counter
7L	7473	"One" Gate
8A	2 ca.555	Left Paddle Generator
8B	7402	Left Paddle On Gate
8C	7432	Paddle Video Collector
8D	7400	Left Paddle Mixer
8E	2 ca.555	Right Paddle Generator
8F	7402	Right Paddle On Gate
8G	7400	Right Paddle Mixer
8H	7410	Game Over Latch
8J	7400	4 Player Latch
8K	7410	Game Over Latch
8L	7400	Input Inverter

(474)

No top Wall 3-H, 3-J, 4-H, 6-E  
Bottom 3-H, 3-J, 4-G, 6-E  
Walls extend too far 3-B, 3-C, 3-H, 3-J, 4-C, 6-C  
Too many nets 3-B, 3-C, 3-D, 3-H, 5-C, 5-L  
No top wall 3-H, 3-K, 3-J, 5-J, 5-L  
Bottom 3-H, 3-J, 3-K, 5-J, 5-L  
Wall extends too far 3-H, 3-J, 5-K

**(474) PADDLE CIRCUITS**

No 2nd set of paddles 8-J  
No paddles 4-G, 7-K, 8-J, 8-K  
No right (#4) pad 7-G, 7-M, 8-C, 8-G, 8-F, 8EB  
No middle (#3) pad 7-E, 7-M, 8-C, 8-D, 8-F, 8-G, 8ET  
No left (#1) pad 8AT, 3-K, 3-M, 7-M, 7-A, 8-B, 8-C  
No left middle (#2) pad 3-K, 3-M, 7-A, 7-M, 8-B, 8-C, 8-D, 8-A  
No paddle movement 4-G, 4-K, 8ATB, 8-ETB  
Paddle at top wall only 4-G, 4-K, 8-ATB, 8-ETB

**SCORE 474**

No score left player 6-G, 6-H, 6-J, 6-L  
No score right player 6-H, 6-G, 6-K, 6-L  
Score missing a segment 5-J, 5-K, 5-L, 6-M  
Counts in even or odd numbers 6-H, 6-J, 6-K, 6-L  
No tens count 5-M, 6-L, 7-J, 7-L  
Counts to nineteen 7-H, 7-J, 7-K, 7-M  
Score is erratic 6-J, 6-K, 6-L, 6-M  
Score does not count 5-G, 6-G, 6-H, 6-J, 6-K, 6-L, 6-M  
Score on left side only 6-K, 6-L, 6-M  
Score on right side only 6-K, 6-L, 6-M  
Score does not blank during game 5-G, 5-H, 6-H, 6-K

**EXECUTIVE CIRCUIT (474)**

No game start 7-K, 8-H, 8-J  
No game over 7-H, 8-J  
No player Vs machine 7-H, 7-J, 7-K, 8-J, 8-L  
No free game 7-H, 7-J, 7-K, 7-M  
No game credit 7-H, 7-J, 7-K, 7-M

**AUDIO (474)**

No sound 1-H, 1-J, 1-L, 2-L, 7-K  
Sound all the time 1-C, 1-J, 1-H, 1-K, 2-L, 4-A, 7-B, 7-F  
No missed sound 1-H, 1-J, 1-K, 4-A  
No wall sound 1-H, 1-J, 1-L, 5-H  
No paddle sound 1-H, 1-J, 1-K, 4-A  
Too many nets 3-C, 3-D, 4-D, 5-C, 5-D

**SYNC (474)**

No clock 1-A, 1-B, 1-C  
No video 1-A, 1-B, 1-C, 1-D, 1-E, 1-F, 1-G, 3-B, 3-C, 3-H, 3-J, 4-C, 4-F, 4-G, 4-H, 4-L, 4-M, 6-C  
No horizontal sync 1-E, 3-M, 4-M  
Distorted video (Picture rolls) 1-E, 3-C, 3-M, 4-M  
No vertical sync 1-E, 3-M, 3-M  
Ball doesn't blank after score 5-G, 5-H, 6-H  
Ball has no horizontal movement 2-A, 2-E, 3-A, 4-A, 5-A, 6-A, 6-B  
Ball has only horizontal movement 2-F, 2-K, 4-E, 5-E, 5-F  
No reverse command 3-A, 4-A, 5-A, 5-D  
No up command 4-E, 5-E, 6-F, 7-B, 7-F, 7-D, 6-E  
No down command 4-E, 5-E, 6-E, 6-F, 7-B, 7-D, 7-F

**(474) BALL GENERATOR**

No ball 2-F, 2-G, 2-K, 2-A, 2-B, 2-D, 2-J, 2-H, 2-L, 3-D, 3-E, 3-F, 3-G, 4-D  
No paddle coincidence 6-F, 8-D, 8-G  
Ball shaped wrong 3-D, 3-E, 3-F, 3-G, 4-D  
Series of Balls 2-A, 2-B, 2-C, 2-E, 3-D, 3-E, 3-F  
Ball will not speed up 4-A, 5-A, 6-A, 6-B, 6-C, 6-D  
No serve 5-G, 5-H, 6-F, 6-H



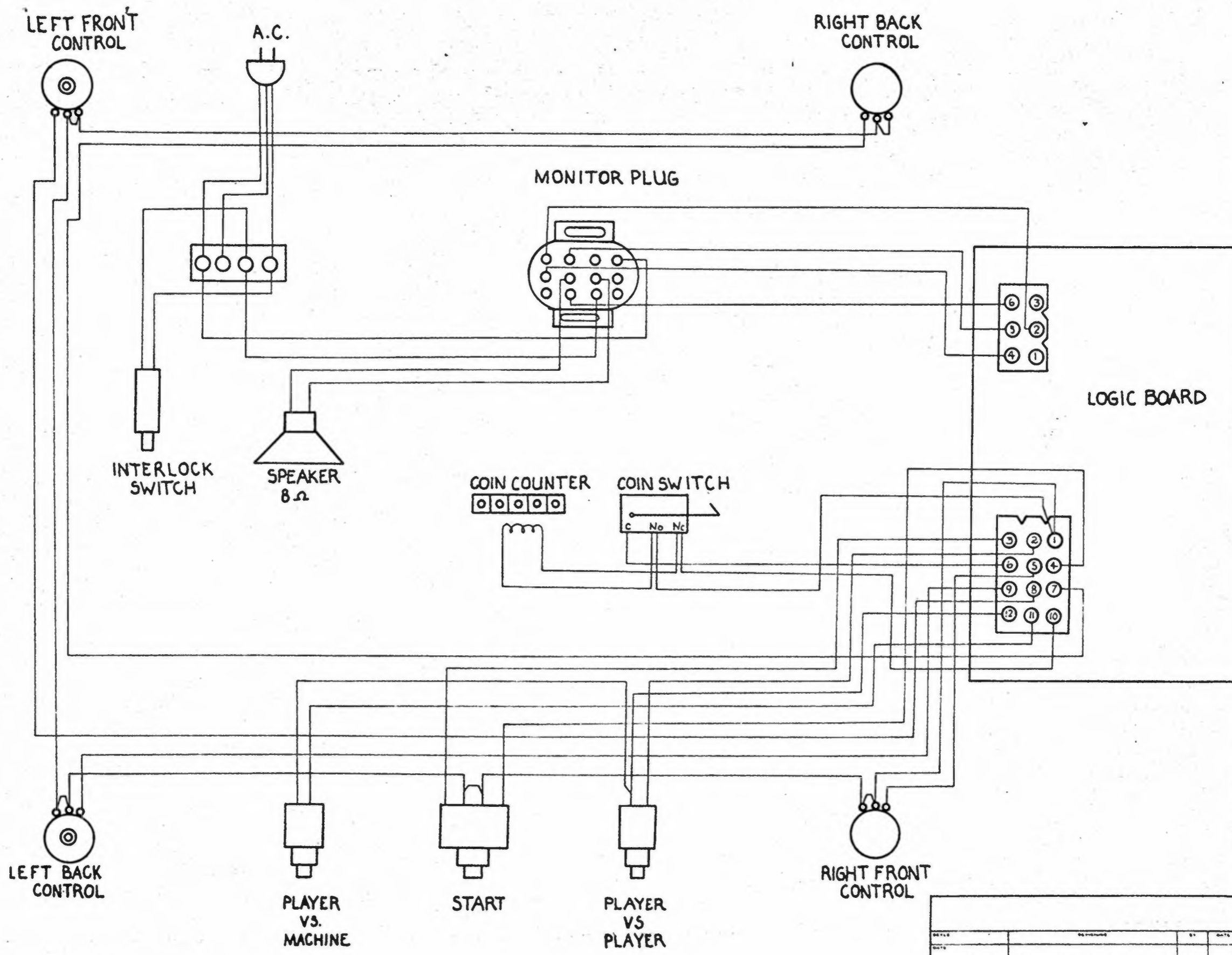
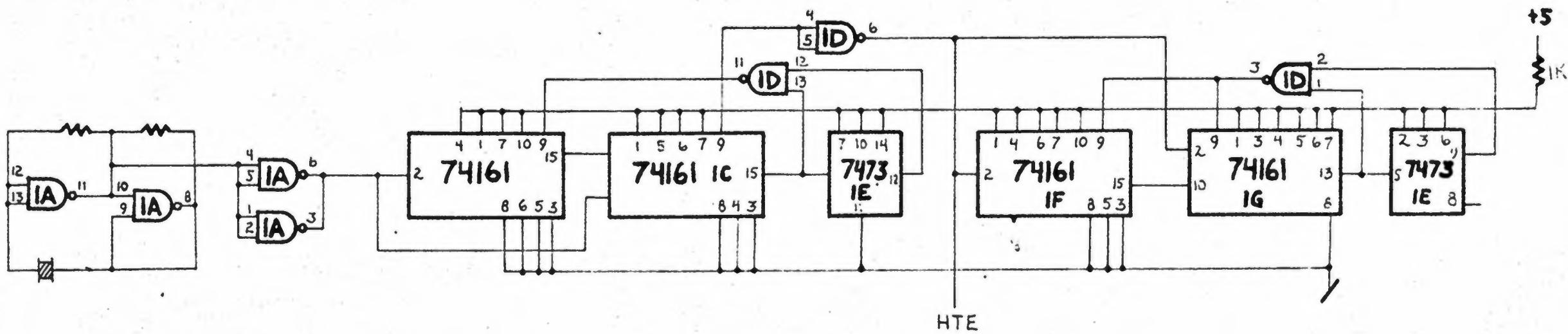


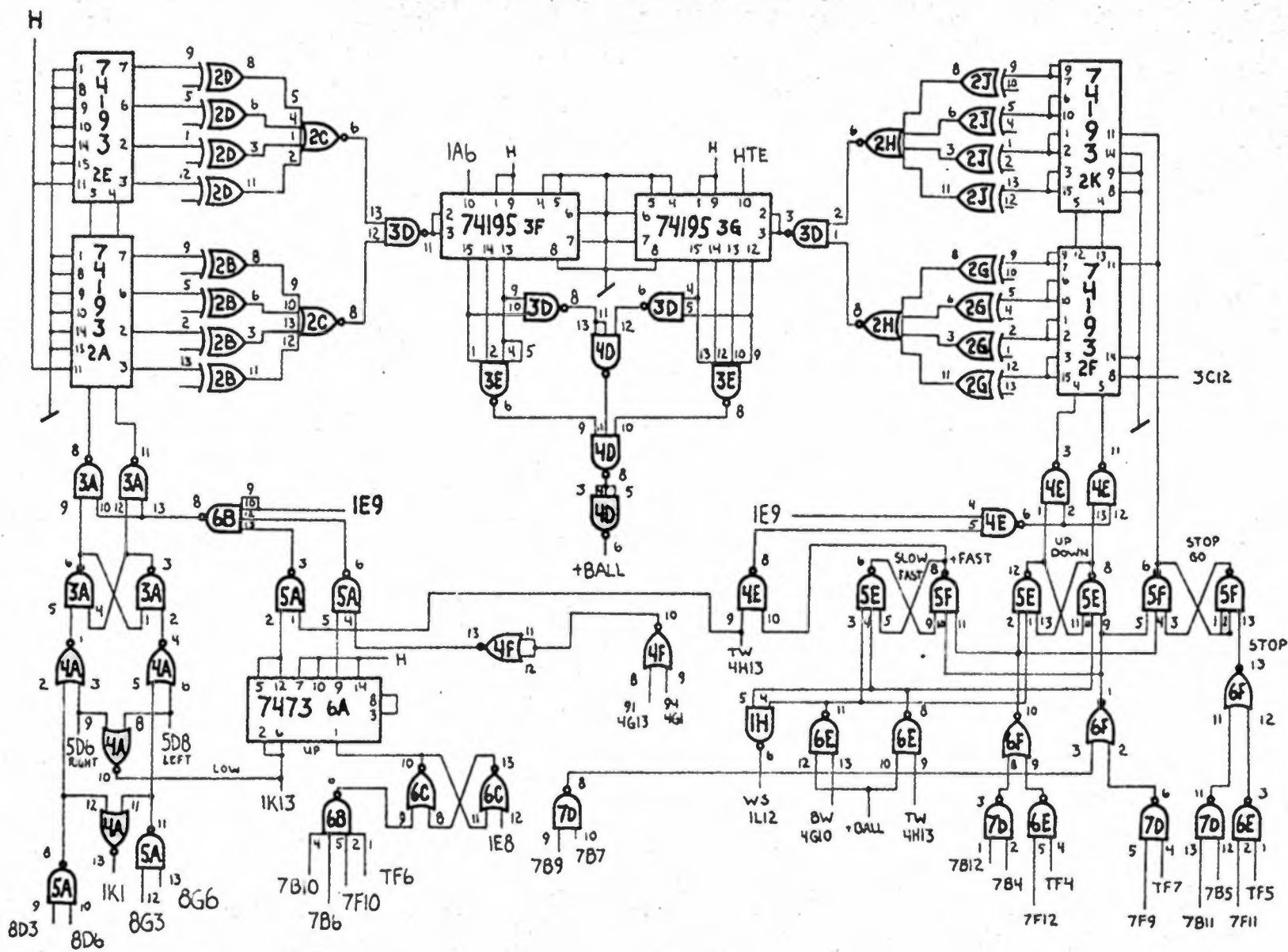
figure iii

DATE	DESIGNED	BY	DATE
DATE			
DATE	MP		
DATE			
474-574			
COCKTAIL CABLE HARNESS			

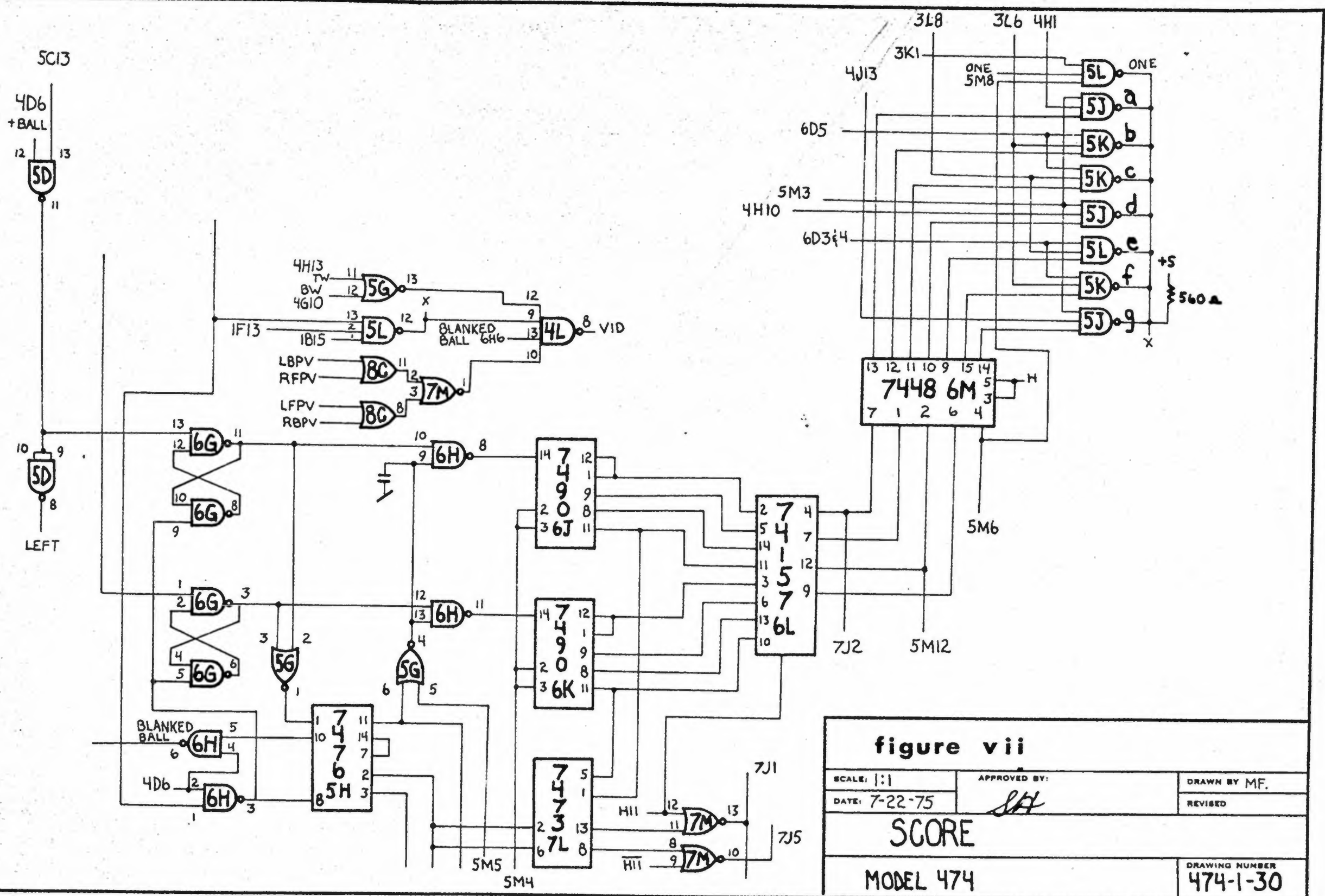


**figure iv**

SCALE: 1:1	APPROVED BY: <i>SA</i>	DRAWN BY MF
DATE: 7-25-75		REVISED
<b>MASTER OSCILLATOR</b>		
MODEL 474	DRAWING NUMBER 474-6-30	

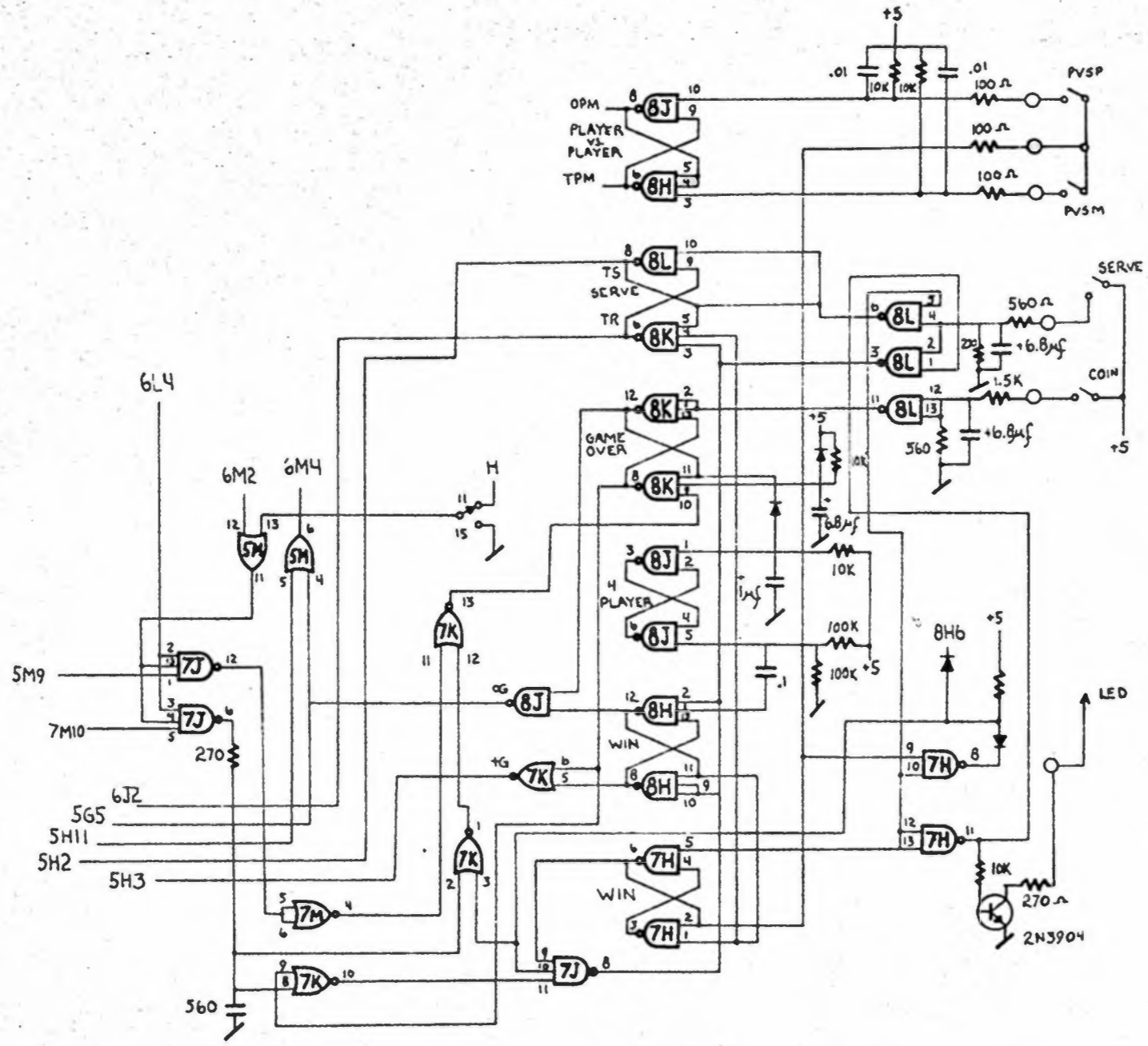






**figure vii**

SCALE: 1:1	APPROVED BY: <i>SAH</i>	DRAWN BY MF.
DATE: 7-22-75		REVISED
<b>SCORE</b>		
MODEL 474		DRAWING NUMBER 474-1-30

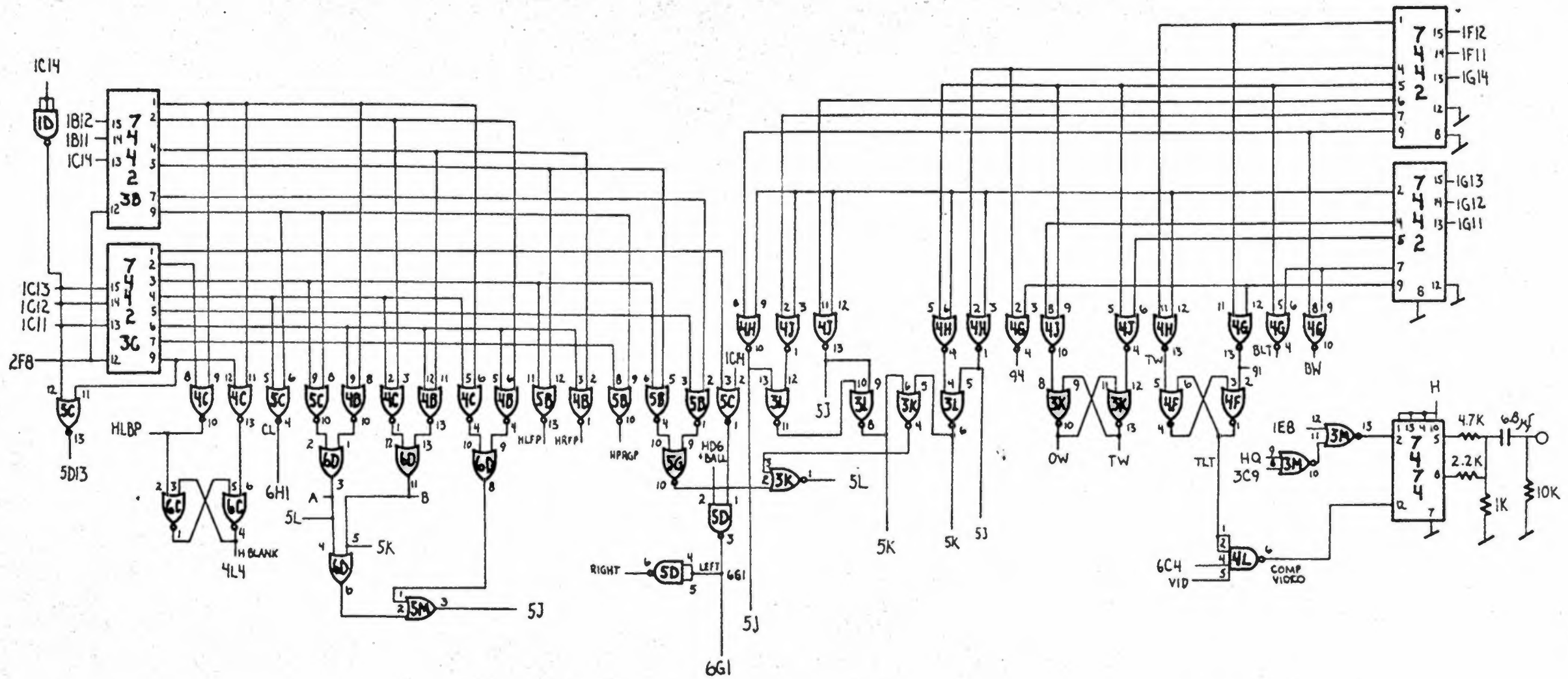


**figure viii**

SCALE 1:1	APPROVED BY	DRAWN BY AIF
DATE 7-24-75	<i>SA</i>	REVISED
<b>EXECUTIVE CIRCUIT</b>		
MODEL 474	DRAWING NUMBER 474-4-30	

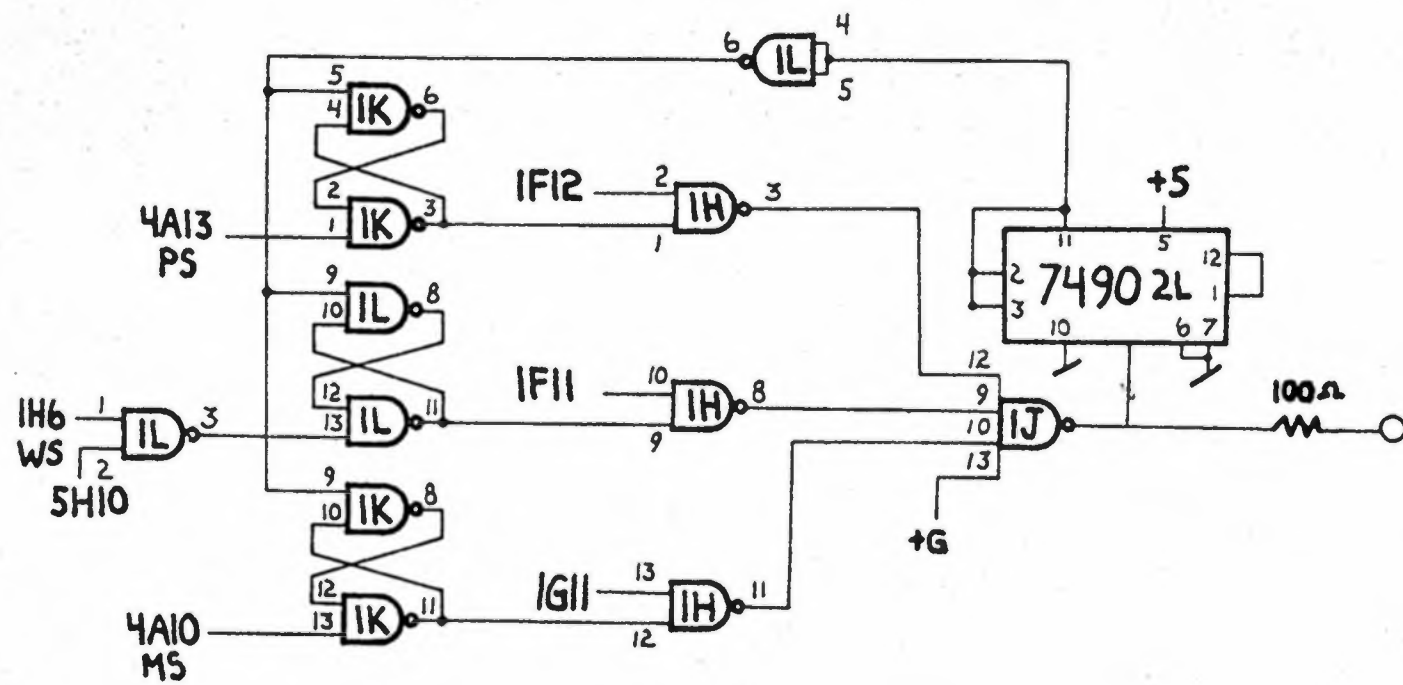
HORIZONTAL

VERTICAL



**figure ix**

SCALE 1:1	APPROVED BY: <i>SA</i>	DRAWN BY: RE
DATE: 7-28-75		REVISED
<b>HORIZONTAL &amp; VERTICAL DECODING</b>		
MODEL 474	DRAWING NUMBER 474-7-30	



**figure x**

SCALE: 1:1

APPROVED BY:

DRAWN BY MF.

DATE: 7-22-75

REVISED

AUDIO

MODEL 474

DRAWING NUMBER  
474-2-30

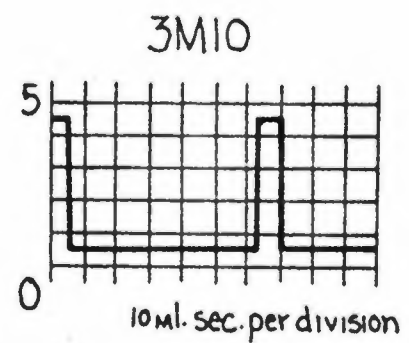
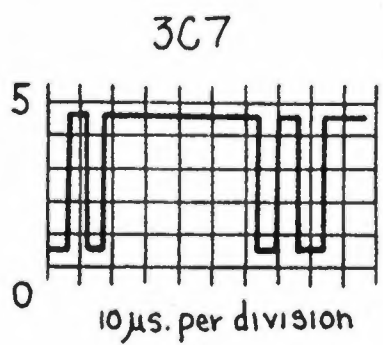
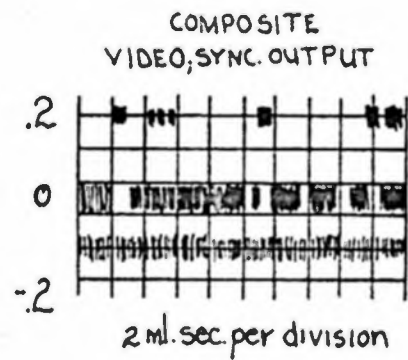
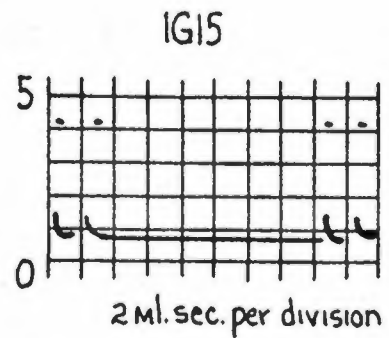
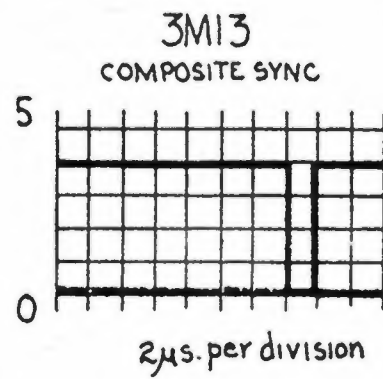
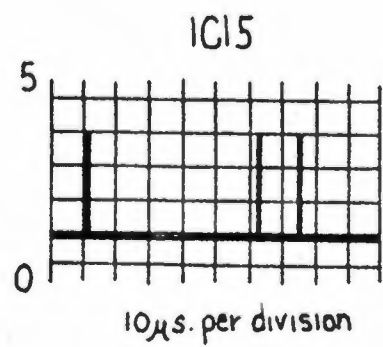


figure xi