

© 1981 - Exidy, Inc.

**Operator's and Service**  
**MANUAL**

**First Edition**



# ADJUSTMENTS

## I. POWER SUPPLY INFORMATION AND ADJUSTMENTS

ALL DC Power required to operate **Cheyenne™** is supplied by the Exidy Power Supply Module. These supply outputs are as follows:

- +5V .....@ 9 AMPS
- +18V .....@ 3 AMPS
- -18V .....@ 3 AMPS

*CAUTION: Only certified technicians should make adjustments on all components of Cheyenne™. Only the +5v DC is adjustable. This must be adjusted to: +5.00 VDC as measured on the PCB near the microprocessor (location J2) (See Fig. 1).*

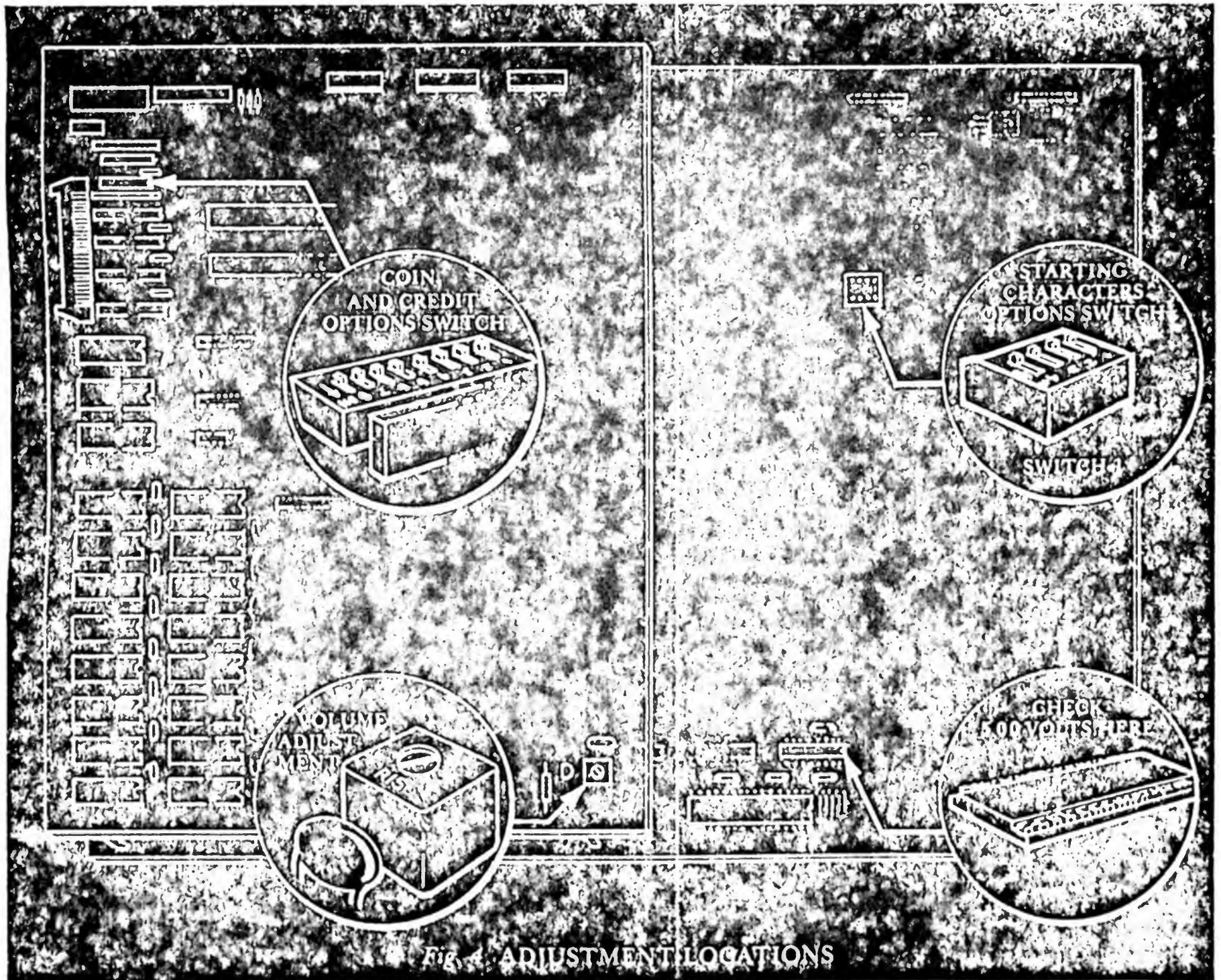

## II. AUDIO BOARD ADJUSTMENTS

Adjust R15 master audio volume control located at position T2 on the Audio Logic Board (See Fig. 1) and adjust audio level while game is in progress. This audio board rides piggyback on the logic board, mounted inside of the cabinet on the side wall (See Fig. 1).



### III. OPERATOR SELECTABLE OPTIONS

Cheyenne™ has several selectable switch options controlled by an 8 position DIP SWITCH located at B1 of the AUDIO BOARD and a 4 position DIP SWITCH located at J19 of the LOGIC BOARD. Both switches are accessible through the rear door of the game.

SWITCH OPTION SETTINGS 8 POSITION SWITCH LOCATION B1					
@ = FACTORY SETTINGS					
COINAGE	SWITCH 1	SWITCH 5	SWITCH 6	SWITCH 7	SWITCH 8
FREE PLAY -	ON	OFF	OFF	OFF	OFF
1 COIN — 1 CREDIT	OFF	OFF	OFF	OFF	OFF
@ 2 COINS — 1 CREDIT	OFF	OFF	ON	OFF	OFF
3 COINS — 1 CREDIT	OFF	ON	OFF	OFF	OFF
4 COINS — 1 CREDIT	OFF	ON	ON	OFF	OFF
1 COIN — 2 CREDITS	OFF	OFF	OFF	OFF	ON
2 COINS — 2 CREDITS	OFF	OFF	ON	OFF	ON
3 COINS — 2 CREDITS	OFF	ON	OFF	OFF	ON
4 COINS — 2 CREDITS	OFF	ON	ON	OFF	ON
1 COIN — 3 CREDITS	OFF	OFF	OFF	ON	OFF
2 COINS — 3 CREDITS	OFF	OFF	ON	ON	OFF
3 COINS — 3 CREDITS	OFF	ON	OFF	ON	OFF
4 COINS — 3 CREDITS	OFF	ON	ON	ON	OFF
1 COIN — 4 CREDITS	OFF	OFF	OFF	ON	ON
2 COINS — 4 CREDITS	OFF	OFF	ON	ON	ON
3 COINS — 4 CREDITS	OFF	ON	OFF	ON	ON
4 COINS — 4 CREDITS	OFF	ON	ON	ON	ON
SWITCH OPTION SETTINGS 4 POSITION SWITCH LOCATION J19					
GAME PLAY DIFFICULTY	SWITCH 1	SWITCH 2	SWITCH 3	SWITCH 4	
1 EASY	ON	ON			
@ 2 NORMAL	OFF	OFF			
3 HARD	OFF	ON			
5 MOST DIFFICULT	ON	OFF			
STARTING CHARACTERS					
2 CHARACTERS			OFF	ON	
@ 3 CHARACTERS			OFF	OFF	
4 CHARACTERS			ON	OFF	
5 CHARACTERS			ON	ON	



#### IV. OPTICAL SENSITIVITY ADJUSTMENT

The Cheyenne uses an Optical Sensor PCB mounted in the forestock to monitor the scanning electron beam of the CRT. Gun positioning information from this Optical Sensor PCB is monitored by the Logic PCB. The Optic PCB sensitivity adjustment allows for monitor intensity, distance between gun and monitor and the electronic circuitry tolerance.

During game play each time the trigger is pulled there will be a white flash and a small dot is displayed wherever the gun is aimed. If for any reason the optic circuitry is not sensing the screen when the trigger is pulled the dot will not be displayed, and an audio warning sound will be heard. When this occurs, the optical sensor sensitivity should be readjusted.

1. To access the optical electronics, remove the (2) button head screws and the (1) cap screw and gently lift the Gun Stock from the Forestock (See Fig. 5).
2. Select the MANUAL DIAGNOSTIC MODE. To enter this mode, hold down the Start Button while applying power.

3. Index the pointer to the CHECK INTERRUPTS test, pull gun trigger and execute. When test is complete it will return to the MANUAL DIAGNOSTIC MENU MODE.
4. Index the pointer to the OPTICAL ADJUSTMENT and pull Gun Trigger, a white screen should appear.
5. If the screen should come up with wavering lines, repower the game and return to MANUAL DIAGNOSTIC MENU. Perform the CHECK INTERRUPTS, then index to the OPTICAL ADJUSTMENT.

(continued)

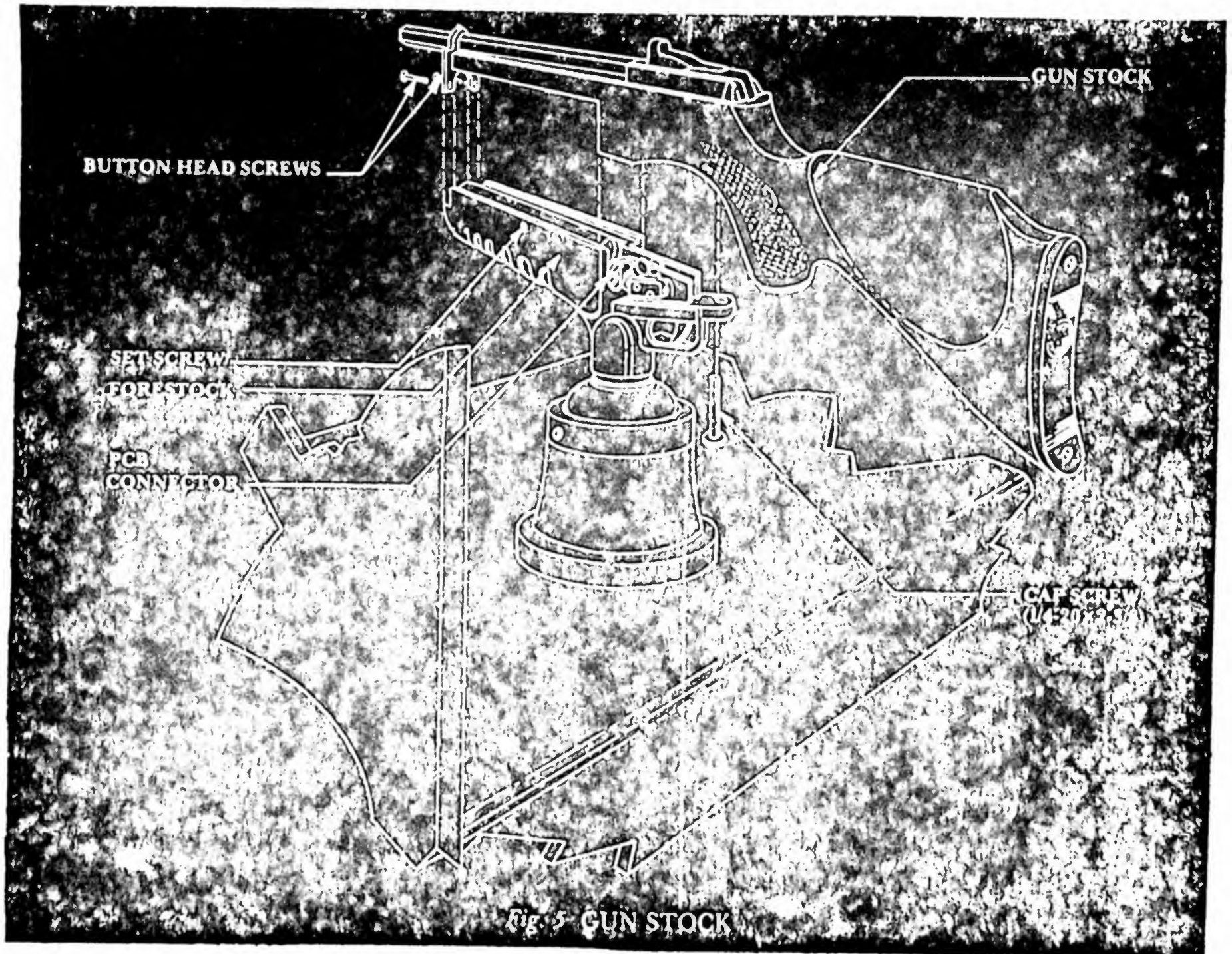

Fig. 5 GUN STOCK



# MODES OF OPERATION

## CHEYENNE™ HAS FOUR MODES OF OPERATION:

- A. AUTO SELF DIAGNOSTIC TEST MODE
- B. MANUAL DIAGNOSTIC MODE
- C. ATTRACT MODE
- D. PLAY MODE

To bypass all diagnostics, press rifle trigger during the power-up sequence.

### AUTO SELF DIAGNOSTIC TEST MODE

RAM TEST  
SCREEN RAM TEST  
CRC OF PROGRAM ROMS  
CHECKSUM OF DATA BANK ROMS  
AUDIO TEST  
E<sup>2</sup> PROM

### MANUAL DIAGNOSTIC MENU MODE

To access the manual diagnostic mode, hold down the START BUTTON on power-up. Once this mode is accessed, any of the listed selections may be indexed by the player start button and executed by the GUN TRIGGER.

### GUN ALIGNMENT

Displays a crosshair (+) for gun sight alignment. Aim the GUN SIGHT at center of crosshair and fire gun once. the GUN SIGHT will be aligned to the last burst.

Press START BUTTON and return to the MANUAL DIAGNOSTIC MENU.

### RAM TEST

Tests RAMS on logic board at locations A8 and A9.\*\*

### SCREEN RAM TEST

Tests RAMS on logic board at locations:\*\*

B14-B21  
C14-C21  
D14-D21  
E14-E21

### CRC CHECK OF PROGRAM ROMS

Tests ROMS on logic board at locations A1, A3, A4, and A6.\*\*

### CHECKSUM OF DATA BANK ROMS

Tests ROMS on logic board at locations:\*

B1, B3, B4, B6, B7, B8, B10  
C8, C10, C11  
D1, D3, D4, D6, D7, D8, D10,  
E1, E3, E4, E6, E7, E8, E10, E11

### AUDIO TEST

Tests the communication between logic and audio board.

### NOTES:

- \* See Diagnostic Error Code FIG. 8 for suspected location of RAM or ROM.
- \*\* The Processor may not run dependent on the extent of chip failure of these locations.

## CHECK INTERRUPTS

Tests for horizontal and vertical frame interrupts.

## GRAY SCALE

Displays a graduated gray scale for monitor check or adjustments.

## CROSSHATCH

Displays horizontal and vertical lines for monitor linearity and convergence checks or adjustments.

## COLOR BARS AND BLOCKS

Displays a color visual test pattern utilizing the background and moving object circuitry. The bars are produced by the background circuitry and the blocks are produced by the moving object circuitry.

## OPTICAL ADJUSTMENTS

Displays a rectangular pattern for adjusting the sensitivity of the Optical Sensing Circuitry.

## RESET TO FACTORY SETTINGS

Sets the high score and also checks the E<sup>2</sup>

ROM\*\*\* located at B11 of the logic board. The E<sup>2</sup> PROM contains the high score table and gun alignment information. Running this diagnostic will reset the high score table. It will also require that the accuracy of the gun alignment be rechecked.

## RESET HIGH SCORE TABLE TO ZERO

Resets all high scores on the high score table to zero. (Same as reset to factory set) except to zero.

## EXIT

Returns game to the ATTRACT MODE.

## FREE PLAY

For those wishing to demonstrate Cheyenne, a freeplay mode may be achieved by turning on switch #1 on audio board at location B1.

## ATTRACT MODE

The attract mode appears after power-up auto self diagnostic and after every game. This mode will continue to display the attract mode repeatedly until a coin, and the start button is pressed.

## HIGH SCORE TABLE

## GAME SCENE

## COIN AND CREDIT INSTRUCTIONS

## GAME PLAY INSTRUCTIONS

### NOTE:

\*\*\* E<sup>2</sup> PROM = Electrically Erasable Programmable READ ONLY MEMORY.



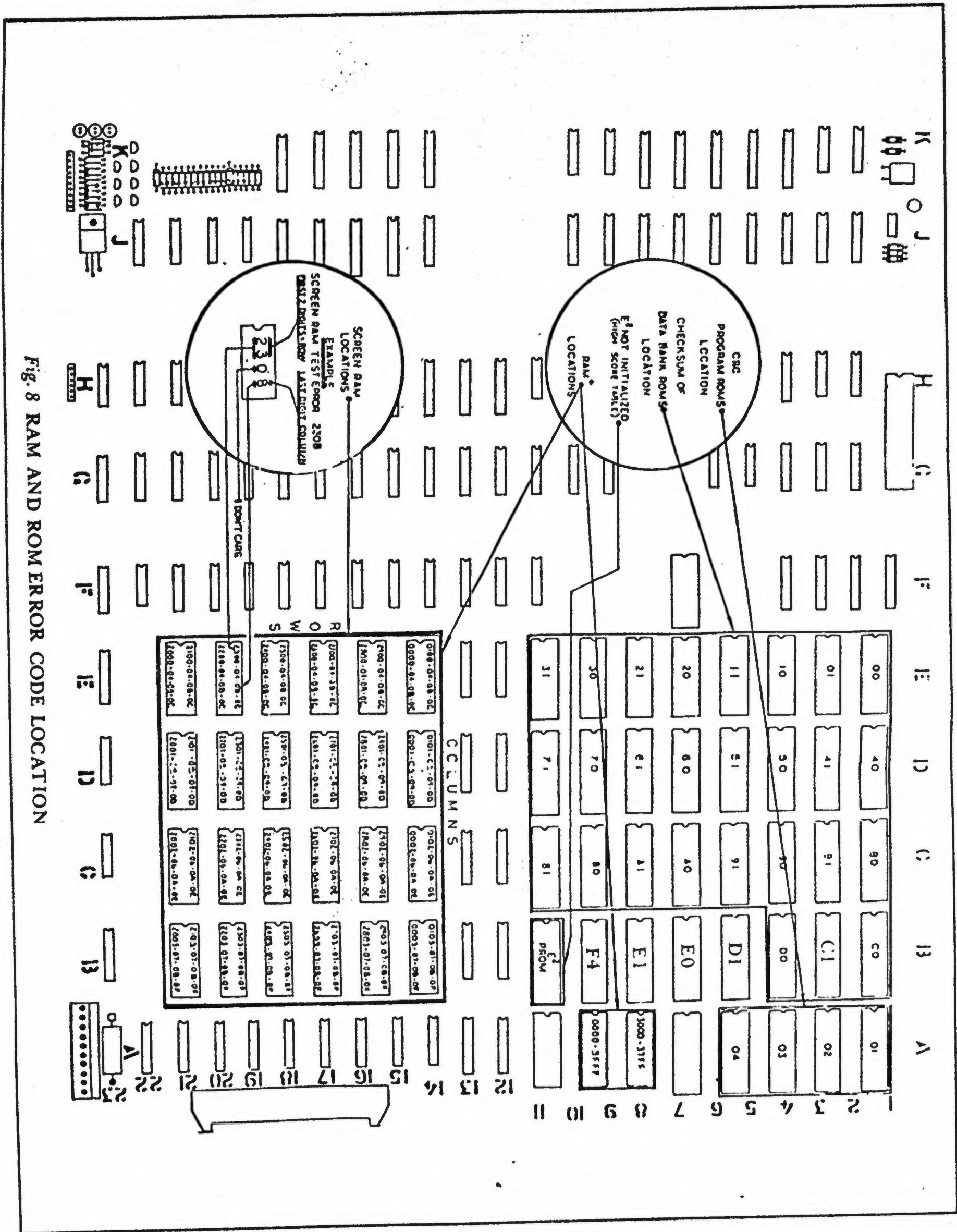

Fig. 8 RAM AND ROM ERROR CODE LOCATION

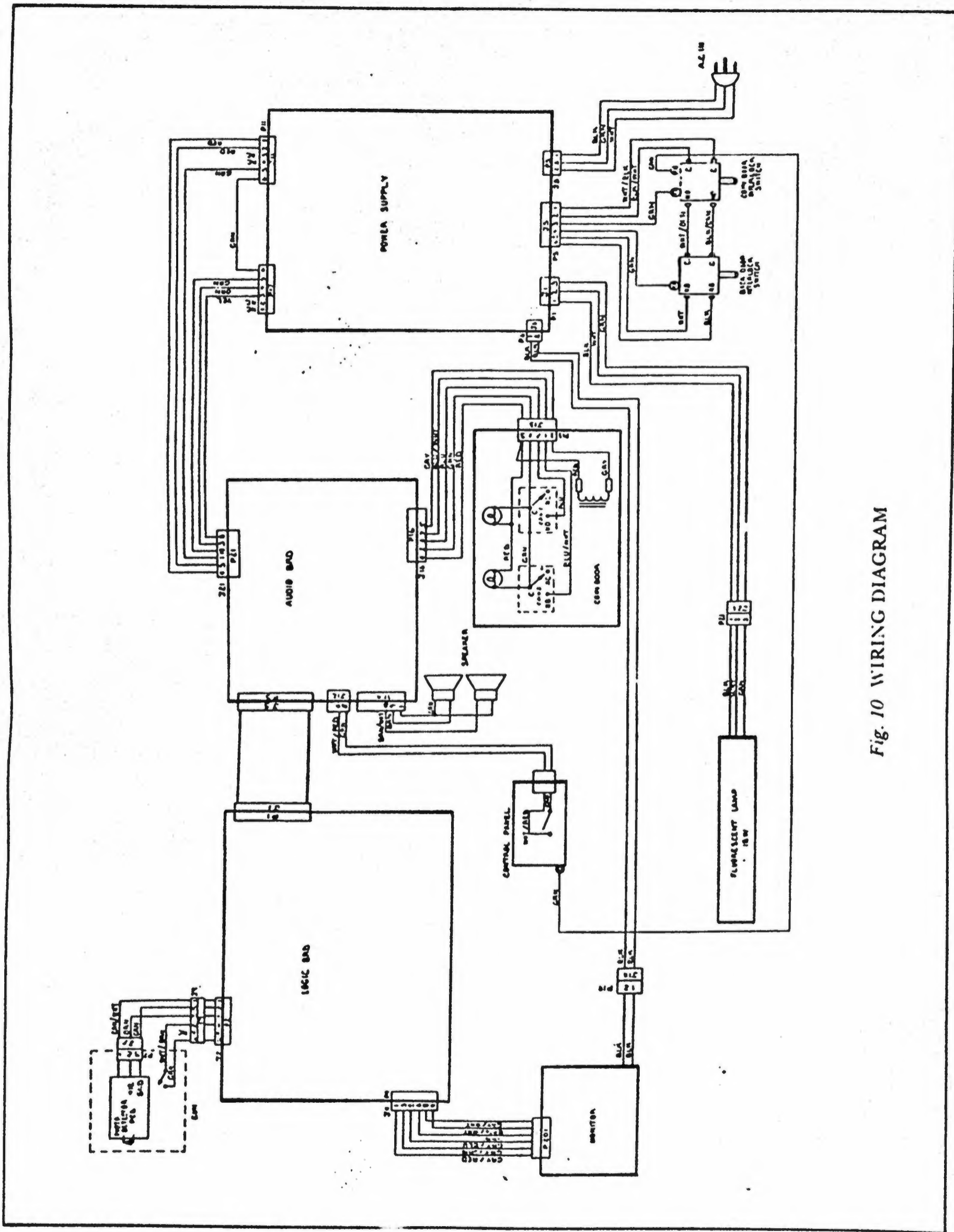

Fig. 10 WIRING DIAGRAM









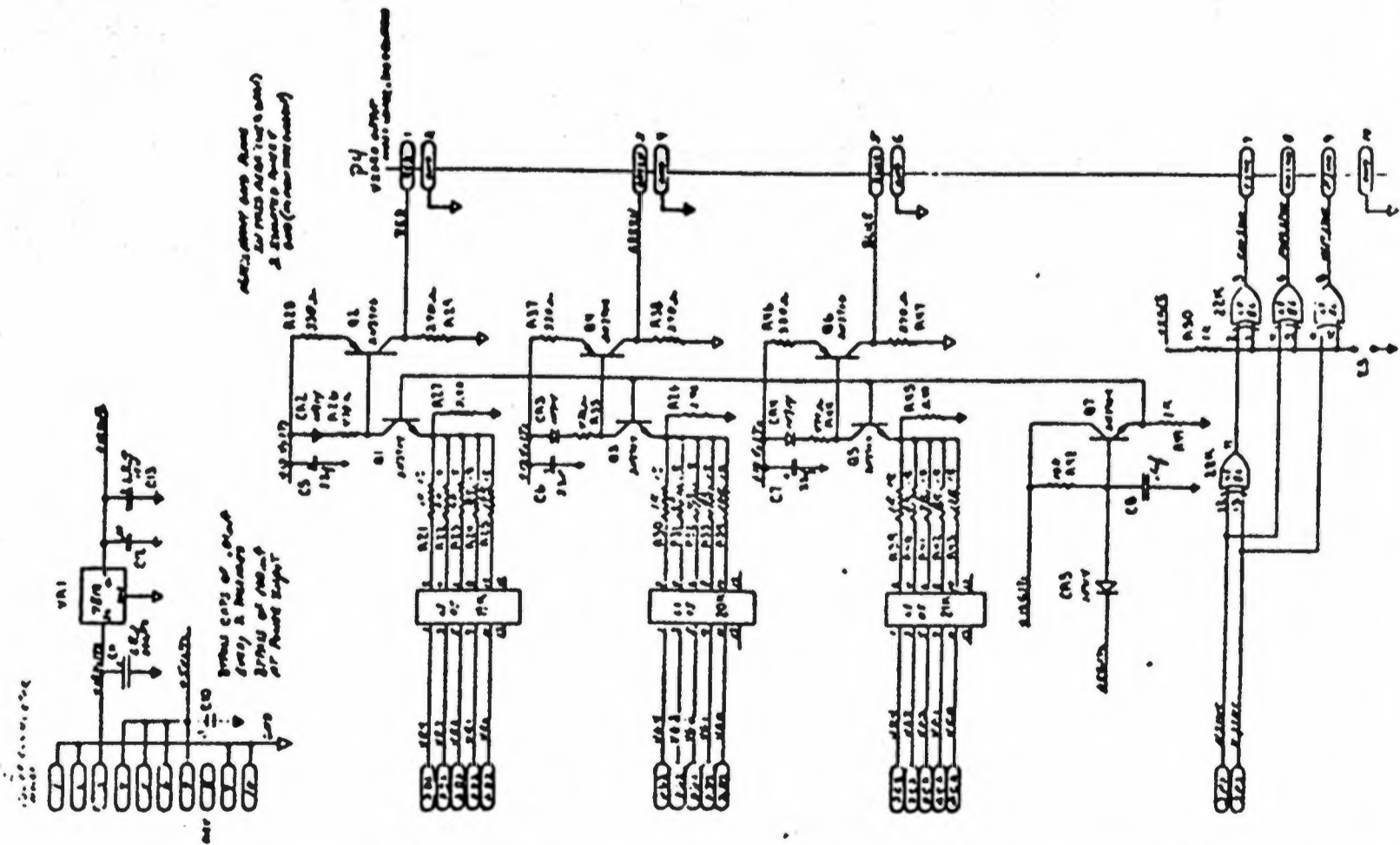

	THE ARMY RESEARCH OFFICE DURHAM, NORTH CAROLINA 27706-0540	D	13000 01/01 440 System	5 6
--	---	---	---------------------------	--------



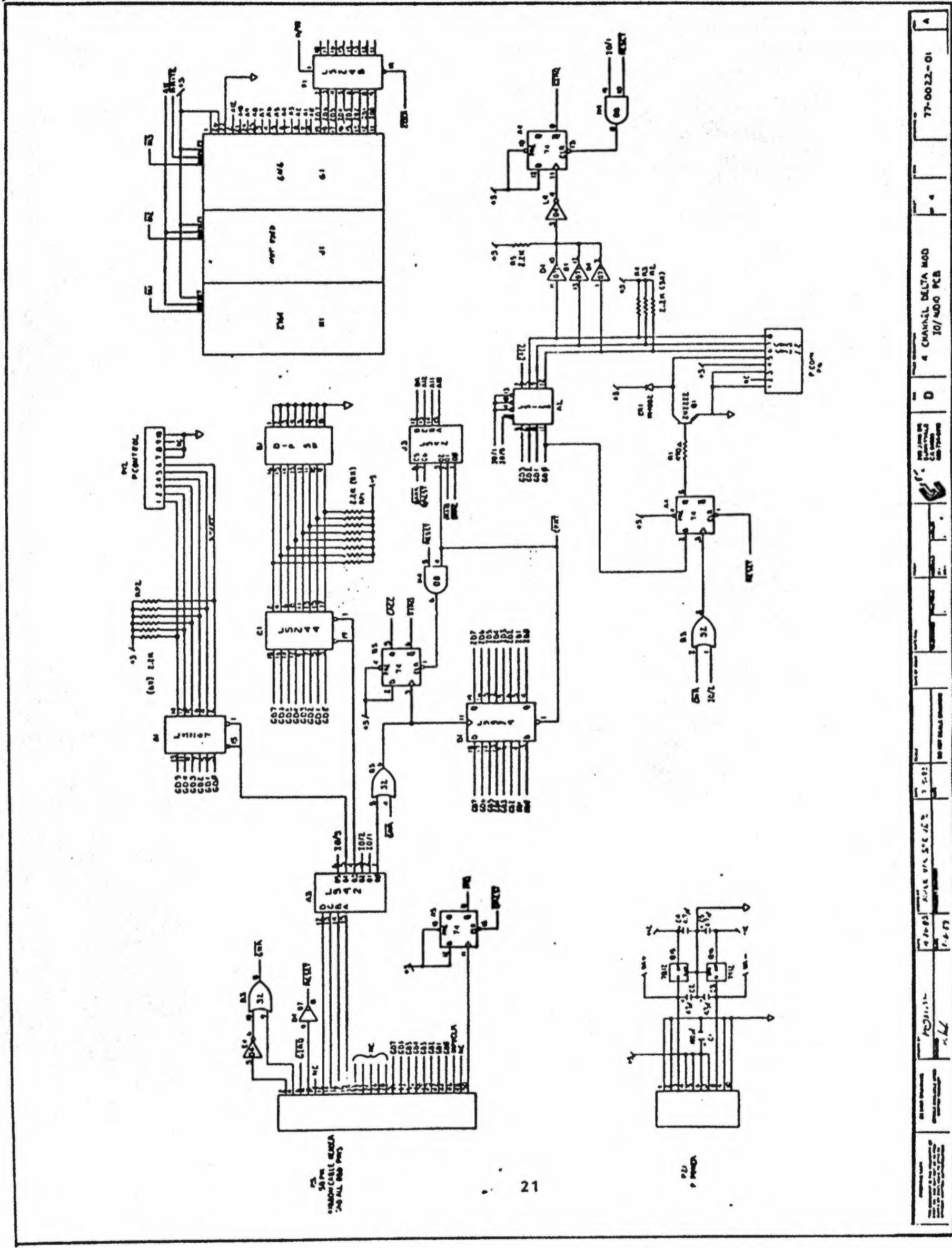

REV. 1	DATE	BY	CHKD	APP'D	77-0022-01
REV. 2	DATE	BY	CHKD	APP'D	
REV. 3	DATE	BY	CHKD	APP'D	
REV. 4	DATE	BY	CHKD	APP'D	
REV. 5	DATE	BY	CHKD	APP'D	
REV. 6	DATE	BY	CHKD	APP'D	
REV. 7	DATE	BY	CHKD	APP'D	
REV. 8	DATE	BY	CHKD	APP'D	
REV. 9	DATE	BY	CHKD	APP'D	
REV. 10	DATE	BY	CHKD	APP'D	
REV. 11	DATE	BY	CHKD	APP'D	
REV. 12	DATE	BY	CHKD	APP'D	
REV. 13	DATE	BY	CHKD	APP'D	
REV. 14	DATE	BY	CHKD	APP'D	
REV. 15	DATE	BY	CHKD	APP'D	
REV. 16	DATE	BY	CHKD	APP'D	
REV. 17	DATE	BY	CHKD	APP'D	
REV. 18	DATE	BY	CHKD	APP'D	
REV. 19	DATE	BY	CHKD	APP'D	
REV. 20	DATE	BY	CHKD	APP'D	
REV. 21	DATE	BY	CHKD	APP'D	
REV. 22	DATE	BY	CHKD	APP'D	
REV. 23	DATE	BY	CHKD	APP'D	
REV. 24	DATE	BY	CHKD	APP'D	
REV. 25	DATE	BY	CHKD	APP'D	
REV. 26	DATE	BY	CHKD	APP'D	
REV. 27	DATE	BY	CHKD	APP'D	
REV. 28	DATE	BY	CHKD	APP'D	
REV. 29	DATE	BY	CHKD	APP'D	
REV. 30	DATE	BY	CHKD	APP'D	
REV. 31	DATE	BY	CHKD	APP'D	
REV. 32	DATE	BY	CHKD	APP'D	
REV. 33	DATE	BY	CHKD	APP'D	
REV. 34	DATE	BY	CHKD	APP'D	
REV. 35	DATE	BY	CHKD	APP'D	
REV. 36	DATE	BY	CHKD	APP'D	
REV. 37	DATE	BY	CHKD	APP'D	
REV. 38	DATE	BY	CHKD	APP'D	
REV. 39	DATE	BY	CHKD	APP'D	
REV. 40	DATE	BY	CHKD	APP'D	
REV. 41	DATE	BY	CHKD	APP'D	
REV. 42	DATE	BY	CHKD	APP'D	
REV. 43	DATE	BY	CHKD	APP'D	
REV. 44	DATE	BY	CHKD	APP'D	
REV. 45	DATE	BY	CHKD	APP'D	
REV. 46	DATE	BY	CHKD	APP'D	
REV. 47	DATE	BY	CHKD	APP'D	
REV. 48	DATE	BY	CHKD	APP'D	
REV. 49	DATE	BY	CHKD	APP'D	
REV. 50	DATE	BY	CHKD	APP'D	
REV. 51	DATE	BY	CHKD	APP'D	
REV. 52	DATE	BY	CHKD	APP'D	
REV. 53	DATE	BY	CHKD	APP'D	
REV. 54	DATE	BY	CHKD	APP'D	
REV. 55	DATE	BY	CHKD	APP'D	
REV. 56	DATE	BY	CHKD	APP'D	
REV. 57	DATE	BY	CHKD	APP'D	
REV. 58	DATE	BY	CHKD	APP'D	
REV. 59	DATE	BY	CHKD	APP'D	
REV. 60	DATE	BY	CHKD	APP'D	
REV. 61	DATE	BY	CHKD	APP'D	
REV. 62	DATE	BY	CHKD	APP'D	
REV. 63	DATE	BY	CHKD	APP'D	
REV. 64	DATE	BY	CHKD	APP'D	
REV. 65	DATE	BY	CHKD	APP'D	
REV. 66	DATE	BY	CHKD	APP'D	
REV. 67	DATE	BY	CHKD	APP'D	
REV. 68	DATE	BY	CHKD	APP'D	
REV. 69	DATE	BY	CHKD	APP'D	
REV. 70	DATE	BY	CHKD	APP'D	
REV. 71	DATE	BY	CHKD	APP'D	
REV. 72	DATE	BY	CHKD	APP'D	
REV. 73	DATE	BY	CHKD	APP'D	
REV. 74	DATE	BY	CHKD	APP'D	
REV. 75	DATE	BY	CHKD	APP'D	
REV. 76	DATE	BY	CHKD	APP'D	
REV. 77	DATE	BY	CHKD	APP'D	
REV. 78	DATE	BY	CHKD	APP'D	
REV. 79	DATE	BY	CHKD	APP'D	
REV. 80	DATE	BY	CHKD	APP'D	
REV. 81	DATE	BY	CHKD	APP'D	
REV. 82	DATE	BY	CHKD	APP'D	
REV. 83	DATE	BY	CHKD	APP'D	
REV. 84	DATE	BY	CHKD	APP'D	
REV. 85	DATE	BY	CHKD	APP'D	
REV. 86	DATE	BY	CHKD	APP'D	
REV. 87	DATE	BY	CHKD	APP'D	
REV. 88	DATE	BY	CHKD	APP'D	
REV. 89	DATE	BY	CHKD	APP'D	
REV. 90	DATE	BY	CHKD	APP'D	
REV. 91	DATE	BY	CHKD	APP'D	
REV. 92	DATE	BY	CHKD	APP'D	
REV. 93	DATE	BY	CHKD	APP'D	
REV. 94	DATE	BY	CHKD	APP'D	
REV. 95	DATE	BY	CHKD	APP'D	
REV. 96	DATE	BY	CHKD	APP'D	
REV. 97	DATE	BY	CHKD	APP'D	
REV. 98	DATE	BY	CHKD	APP'D	
REV. 99	DATE	BY	CHKD	APP'D	
REV. 100	DATE	BY	CHKD	APP'D	



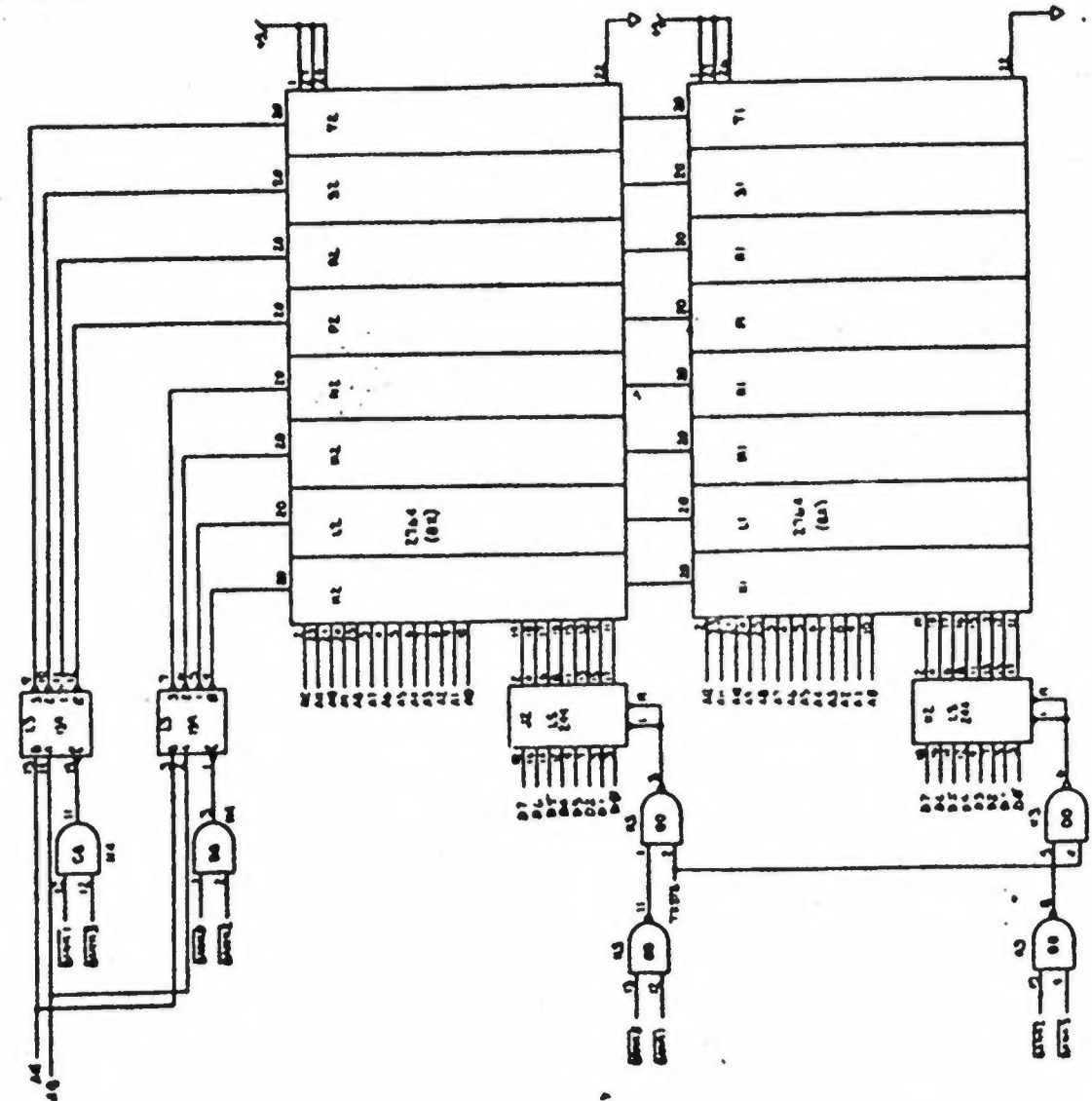
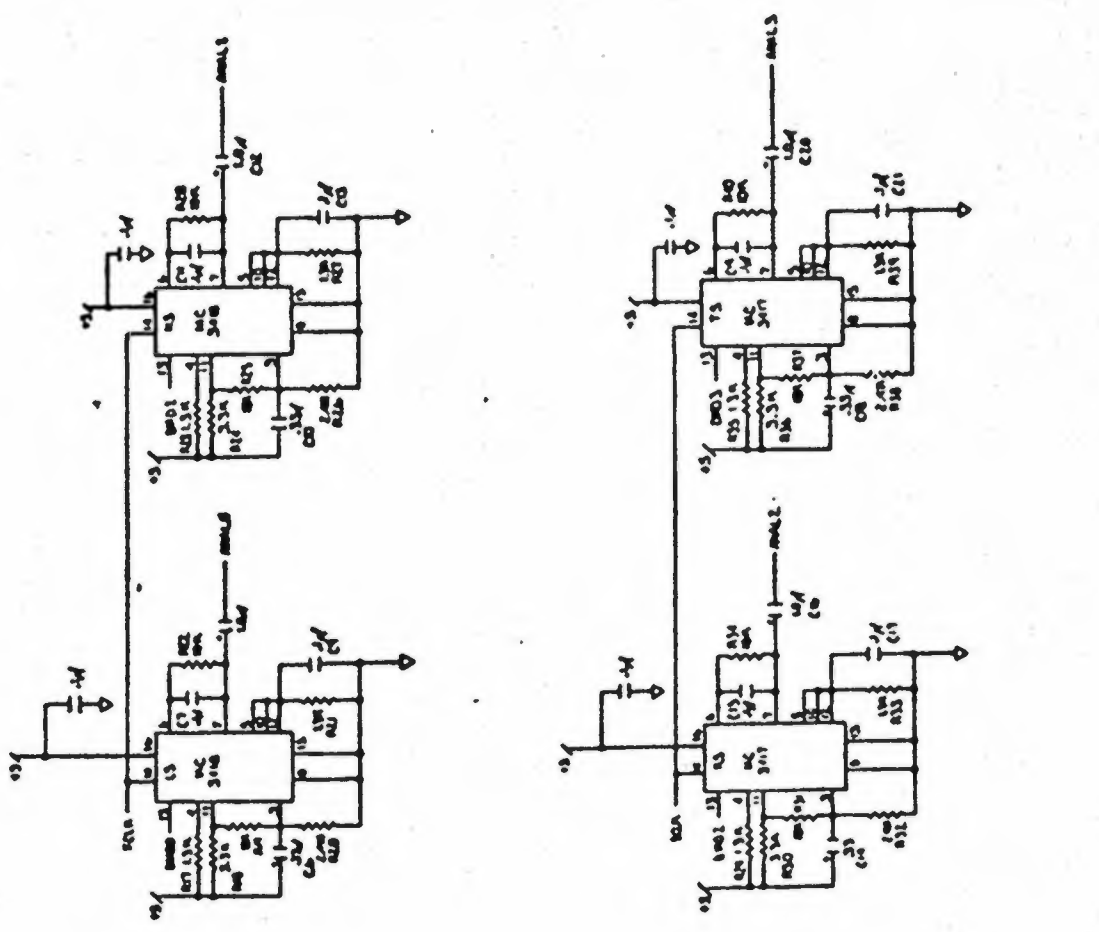

REV. 1	DATE: 11/1/77	BY: J. J. [Signature]	77-0022-01
4 CHANNEL DELTA MOD 10 / AUDIO PCB		D	
ALL DIMENSIONS ARE IN INCHES DIMENSIONS IN PARENTHESES ARE TYPICAL DIMENSIONS IN BRACKETS ARE MINIMUMS DIMENSIONS IN SQUARE BRACKETS ARE MAXIMUMS			



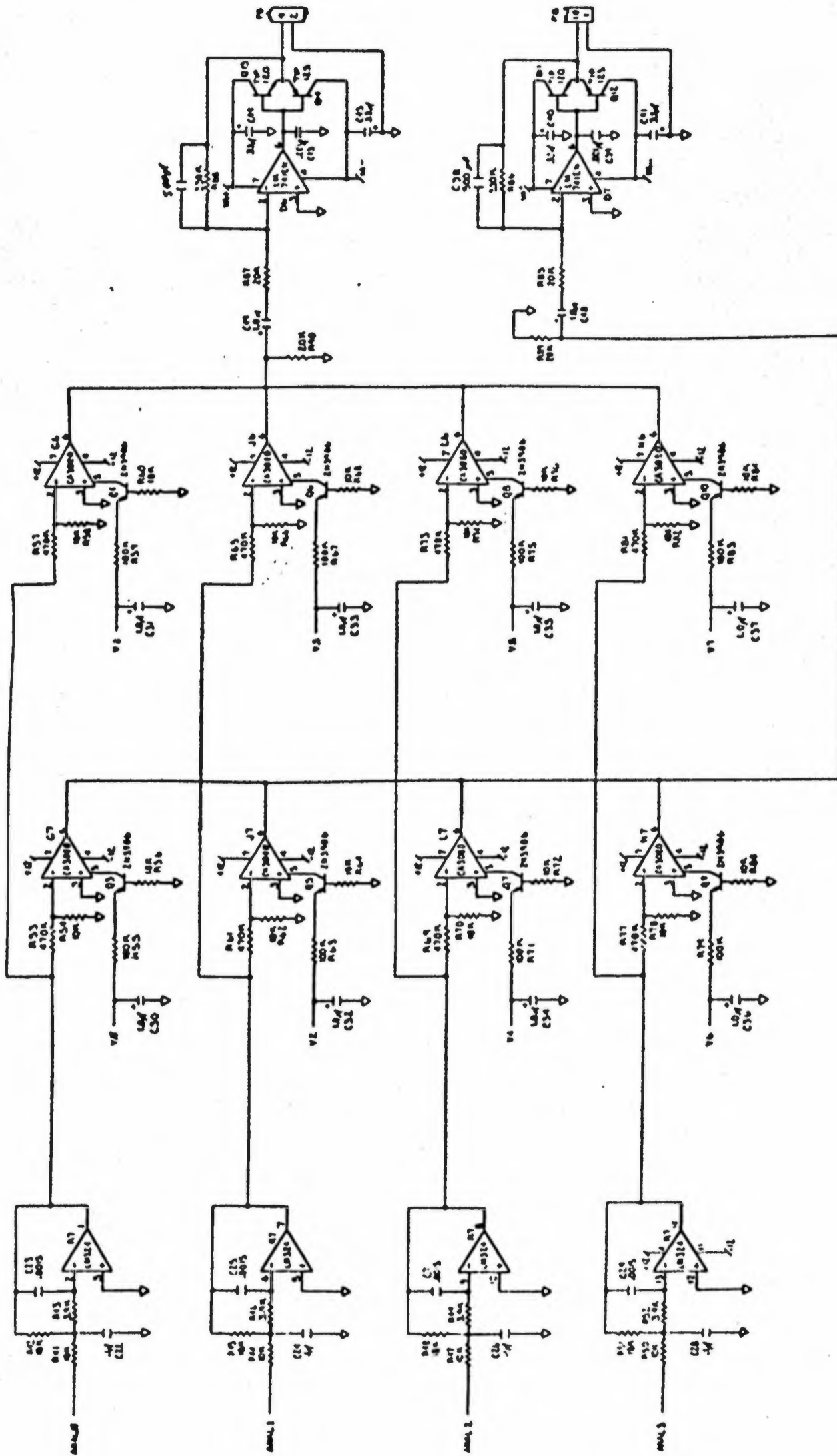

77-0022 -01	REV. 4	4 CHANNEL DELTA MOD 10/ AUDIO PCB	D	DESIGNED BY CHECKED BY DATE	DATE	DATE	DATE	DATE	DATE
-------------	--------	--------------------------------------	---	-----------------------------------	------	------	------	------	------

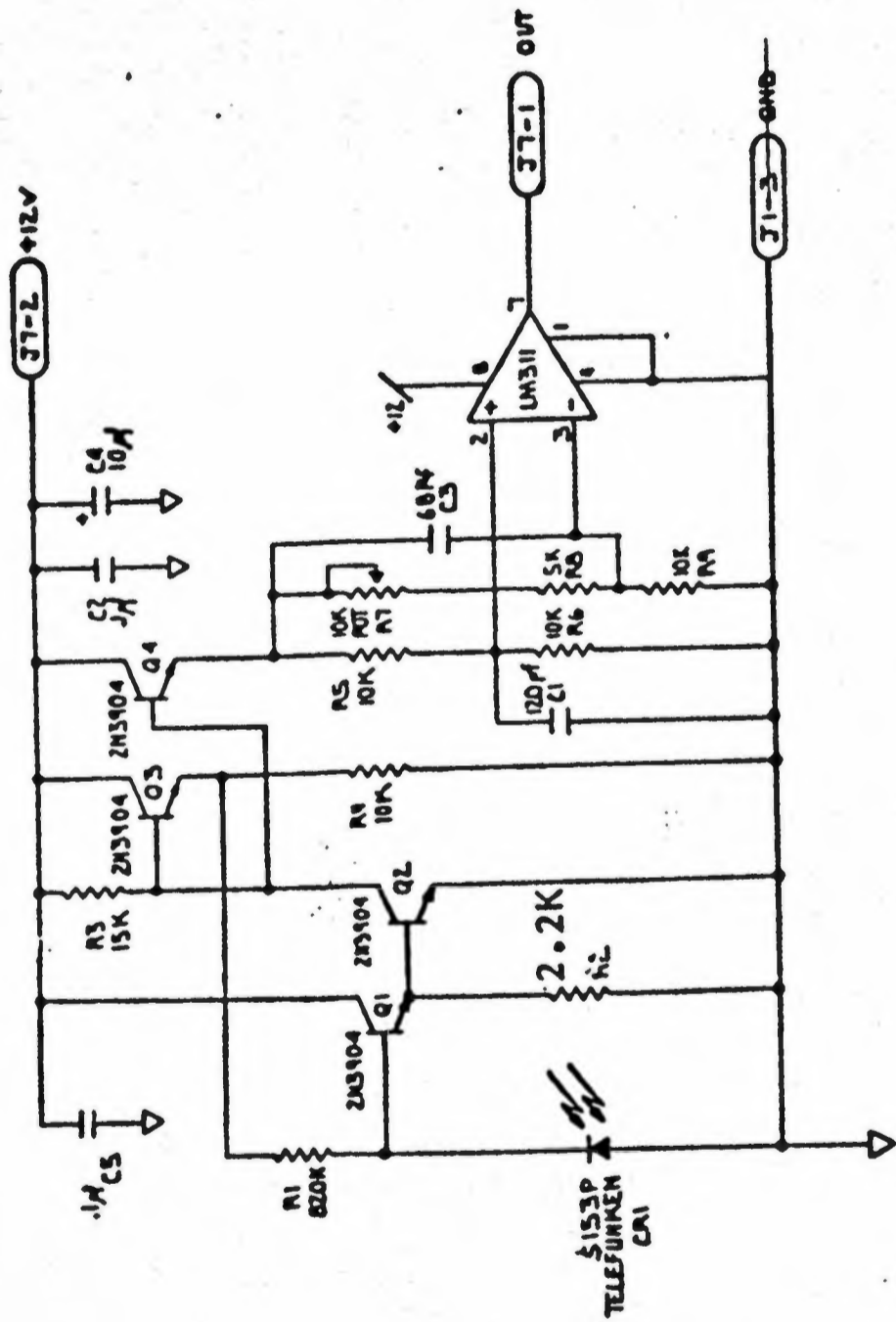

ITEM	PART NUMBER	DESCRIPTION	QTY
1	U4311	OP AMP	1
2	Q1, Q2, Q3, Q4	2N3904	4
3	R1, R2, R3, R4, R5, R6	RESISTORS	6
4	C1, C2, C3, C4	CAPACITORS	4
5	J1-1, J1-2, J1-3	CONNECTORS	3
6	5153P	TELEFUNKEN CA1	1
PHOTO DETECTOR PCB			
C 8			77-0020-01
300 JAVA DR SUNNYVALE, CA 94088 408-734-9418			

PRODUCTION NOTES:  
 1. JUMPER INSTALLED TO EQUALIZE BRIDGE LEGS.  
 2. Q1 AND Q2 IN BRIDGE BALANCED TO MIN TRANSMITTER E.

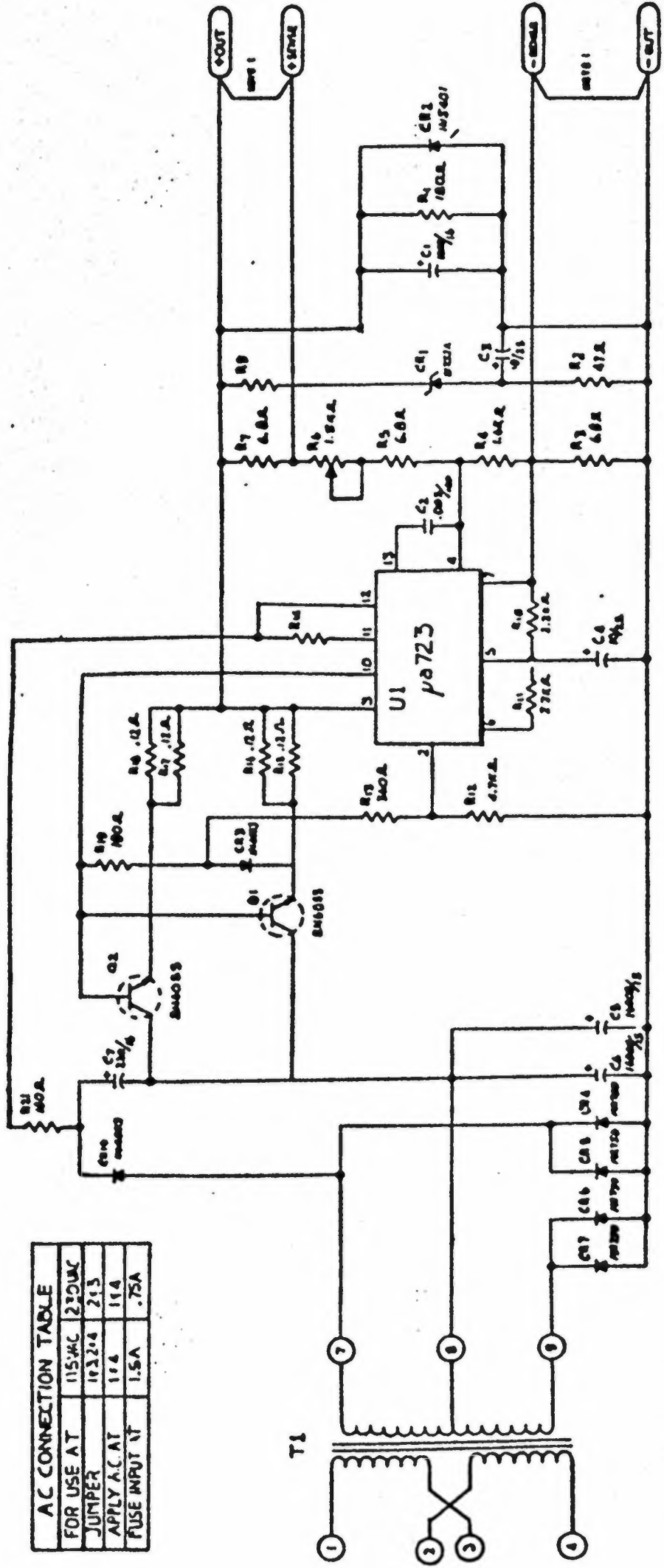

AC CONNECTION TABLE			
FOR USE AT	115VAC	230VAC	
JUMPER	1932/4	213	
APPLY A.C. AT	114	114	
FUSE INPUT AT	1.5A	.75A	

+ 5 VOLT REGULATOR SUPPLY

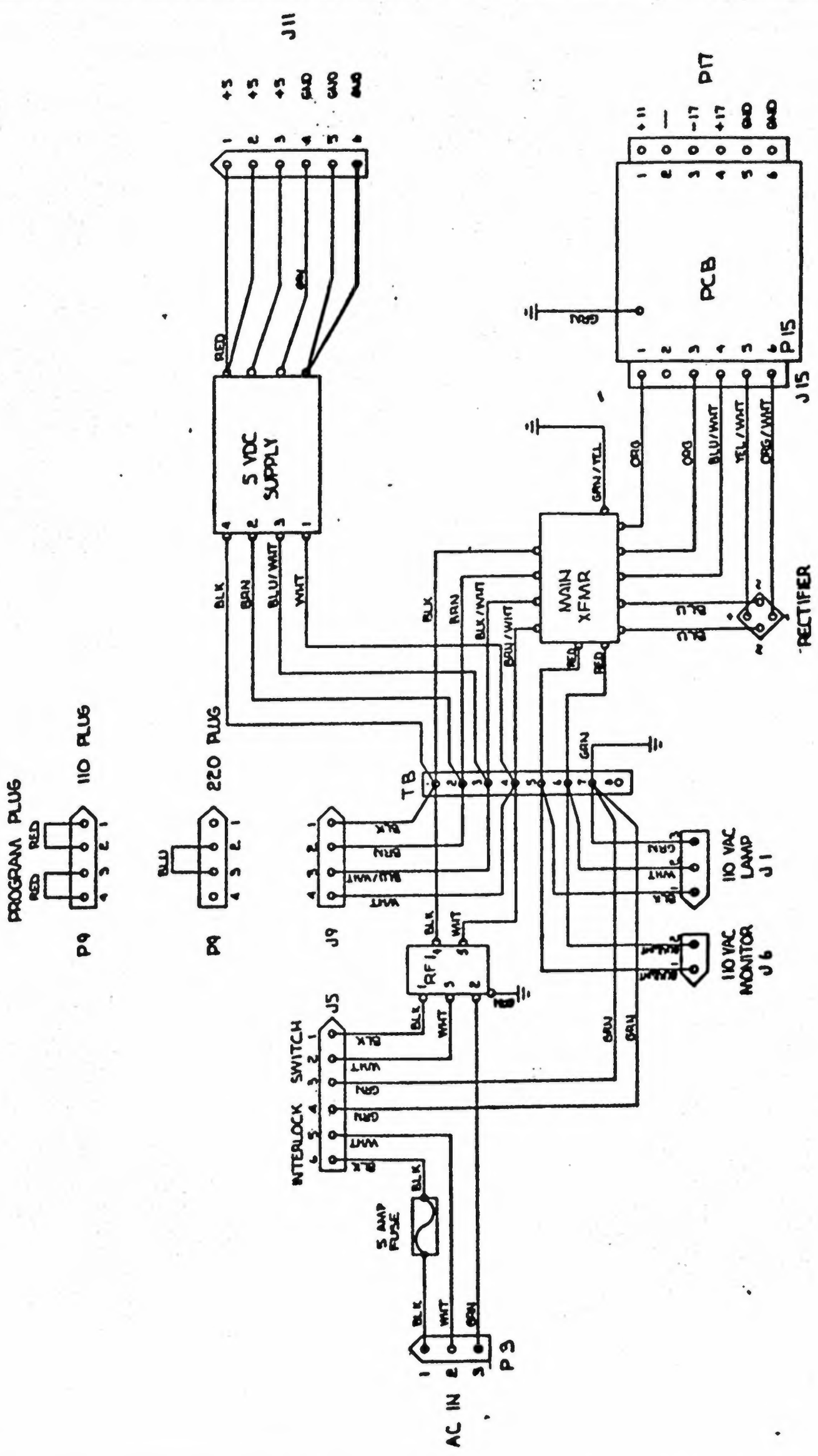

HSC POWER SUPPLY WIRING DIAGRAM

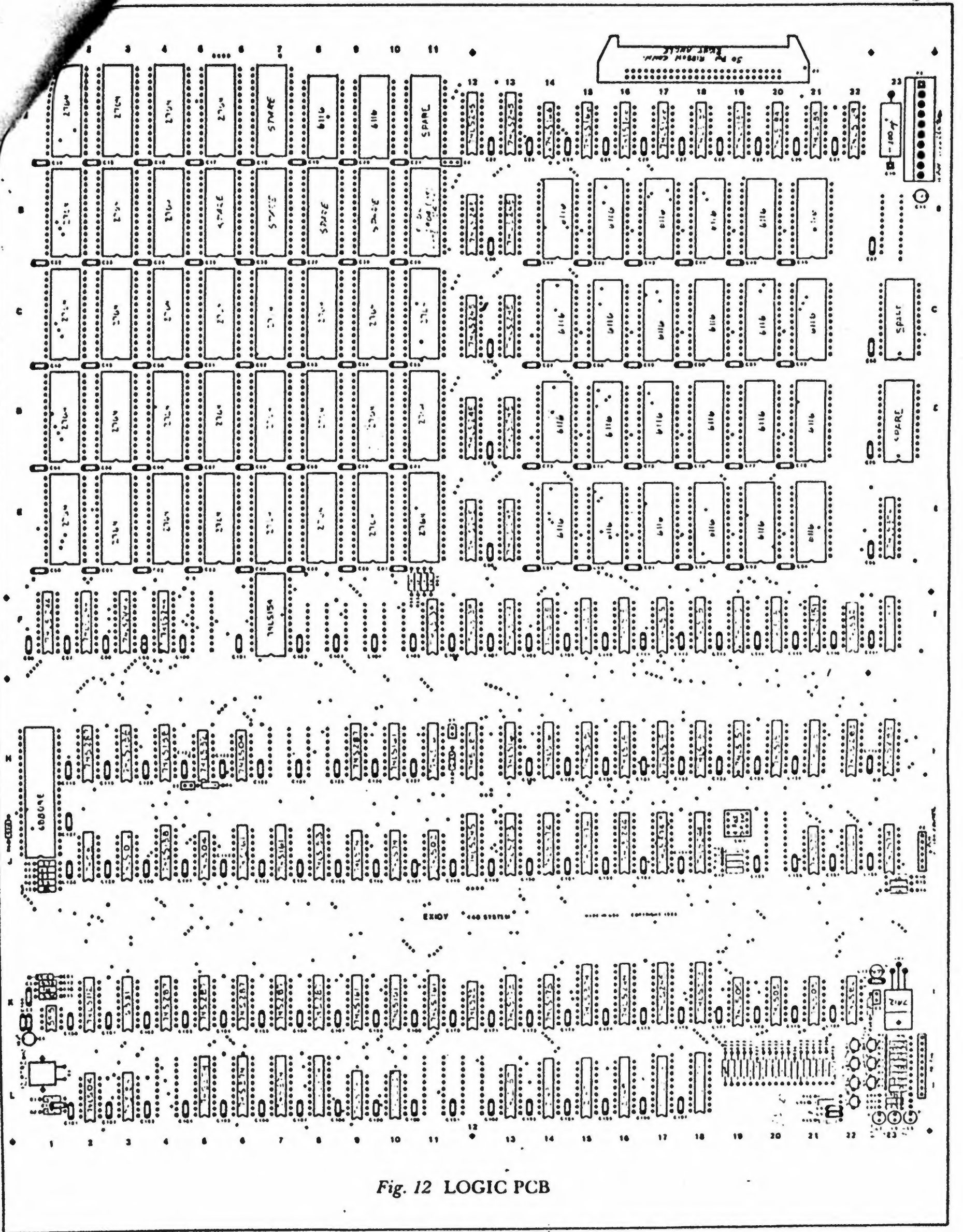

Fig. 12 LOGIC PCB

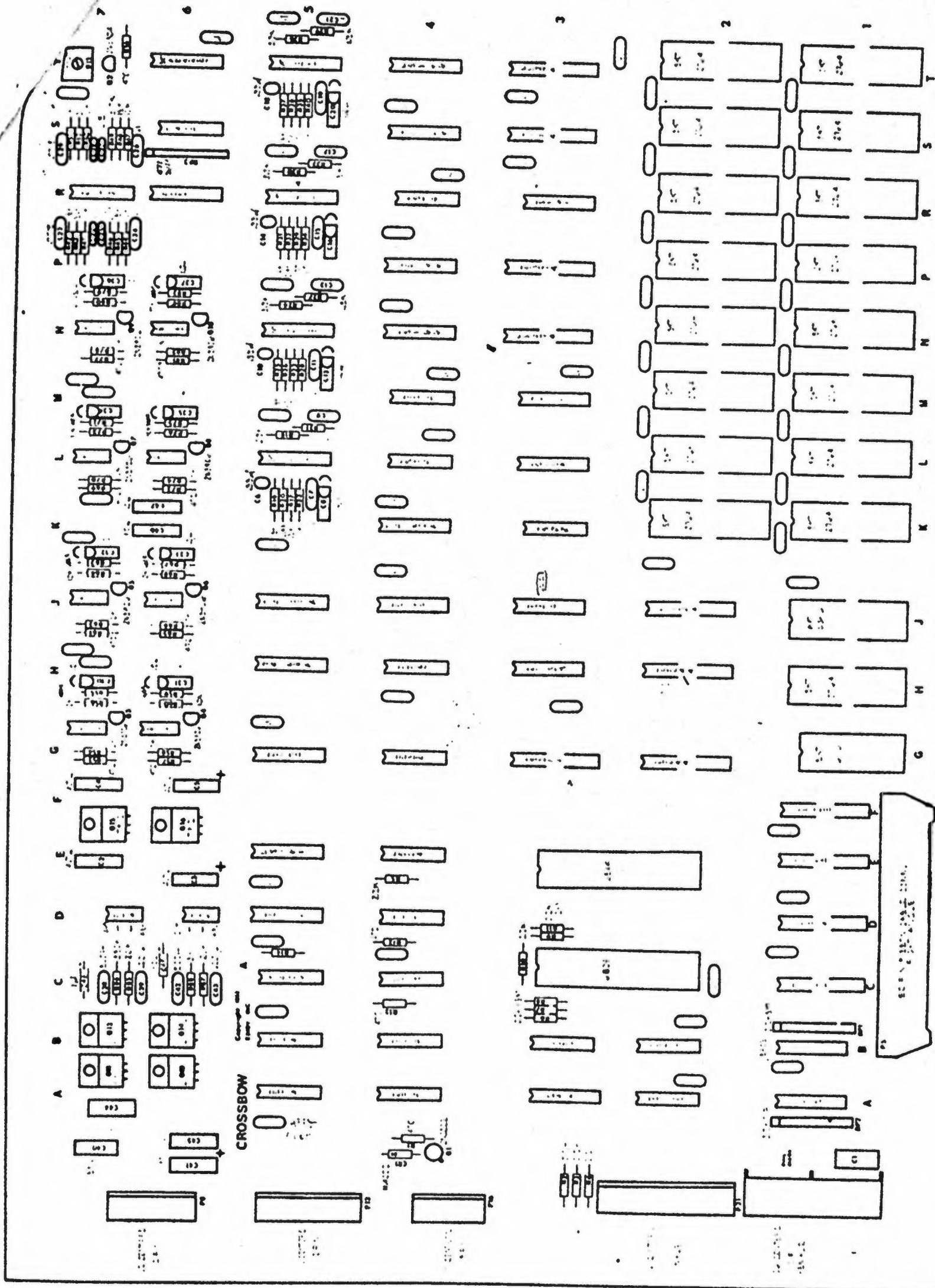

Fig. 13 AUDIO PCB

## OPTICAL SENSOR PCB

PART NUMBER	DESCRIPTION
77-0020-04	PHOTO DETECTOR PCB BLANK
77-0020-05	PHOTO DETECTOR PCB
22-0070-00	I.C., LM311
21-0007-00	TRANSISTOR, 2N3904
20-0012-00	DIODE, PHOTO (TELEFUNKEN 153P)
13-1062-00	CAPACITOR, 10 $\mu$ F
10-1044-1	CAPACITOR, .1 $\mu$ F
10-1201-02	CAPACITOR, 120PF CERAMIC DISC.
10-6800-02	CAPACITOR, 68PF CERAMIC DISC.
07-0004-00	CAPACITOR, VARIABLE 10K TEN TURN TRIMPOT
02-1032-00	RESISTOR, 10K
02-1532-00	RESISTOR, 15K
02-2222-00	RESISTOR, 2.2K
02-5022-00	RESISTOR, 5K
02-8242-00	RESISTOR, 820K

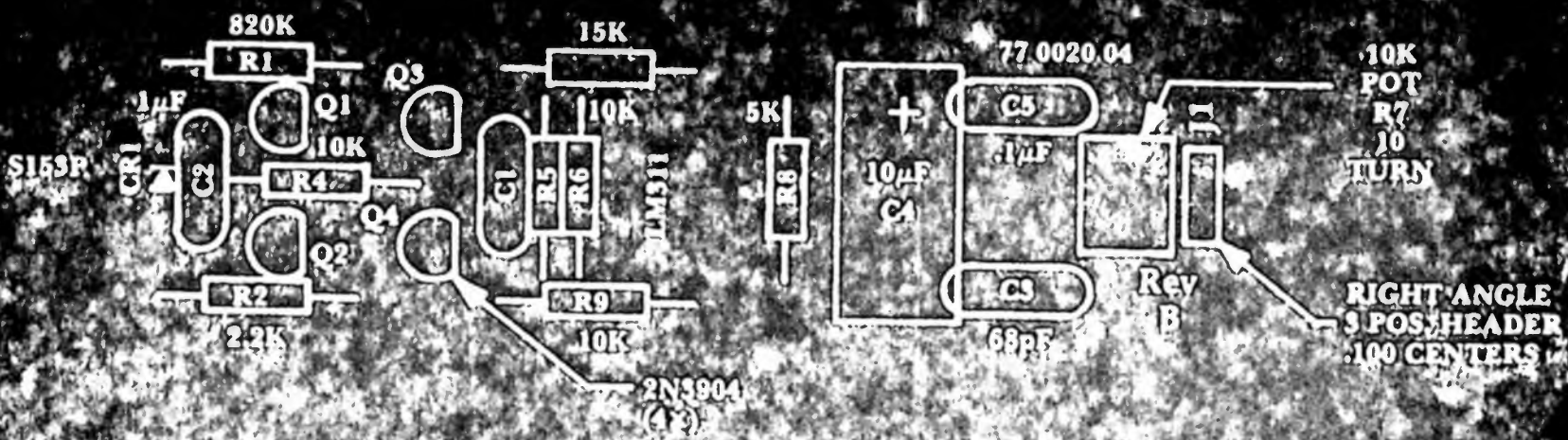

Fig. 15 OPTICAL PCB

### MISCELLANEOUS

PART NUMBER	DESCRIPTION
00-0007-00	CHEYENNE™ MANUAL
49-0069-05	AC POWER CORD
35-0001-00	AC LINE FUSE 5 AMP
135-0024-00	110 AC PROGRAM PLUG
137-0025-00	220 AC PROGRAM PLUG

