

CKIDZO-MANUAL

MEADOWS GAMES INC.

181 COMMERCIAL • SUNNYVALE, CALIFORNIA 94086 • PHONE (408) 732-8110

CKIDZO MANUAL

Table of Contents

Machine Set Up	Page 1 - 2
Game Sequence	2 - 3
Game Timer	3
Monitor Adjustment	3 - 4
Paddle Adjustment	4 - 5
Preliminary Adjustment	5
Coin Acceptor	5 - 7
Trouble Shooting - Testing	7 - 9

Diagrams & Illustrations

Joystick W/Plate	Figure 1
Cabinet Top	2
Logic Board	3
Joystick Exploded	4
Coin Acceptor Exploded	5
Coin Face Exploded	6
Harness Diagram	7

Monitor Service Manual

Warranty Information

Each game manufactured by Meadows Games, Inc. carries a full, one (1) year warranty on the P.C. logic board (and its components).

The Motorola T.V. Montitor carries a six (6) month warranty on parts and labor.

To honor the warranty, Meadows Games must have the cabinet S/N in reference to any repair work. This will negate any service charges that would otherwise apply.

All incoming equipment must travel freight prepaid.

New Machine Set-Up and Check-Out Procedures

After uncrating, save all packing materials in the event machine needs to be returned.

As each new Ckidzo leaves the factory, every component and subassembly is carefully checked for proper operation. However, since parts may have been damaged or factory adjustments changed due to shaking and jarring during shipping, the following check-out procedure must be performed prior to placing the machine on location.

- a. With the machine unplugged, open coin acceptor door and raise the top by removing the threaded spindle lock. Carefully inspect both the exterior and interior for any obvious damage to the cabinet or internal components which may have occurred during shipping. If any such damage is discovered, immediately contact the freight carrier.
- b. Inspect the interior of the machine more carefully, looking for broken or disconnected wires, sub-assemblies not securely mounted, and any foreign objects shorting or interfering with electrical connections. Pay particular attention to the connections to the TV monitor, the players' controls, and the coin switch. Check the security of the computer PCB edge connectors.
- c. Plug the machine in and check the T.V. Monitor image which should be steady, centered, sharp, and exhibit the proper levels of brightness and contrast. With the machine plugged in, but not started, the T.V. Monitor will display the Attract Mode (see next section for Attract Mode explanation).

d. Insert several old and new coins into the coin acceptor. No genuine coin should be rejected. Operated the coin return button while checking the sign of stickiness or binding. Lightly spray the coin acceptor and return button with a silicone lubricant.

e. Check the computer for proper operation by playing several games and compare the results with game sequence analysis in the next section.

The Game Sequence

With the game plugged in but not started, the T.V. Monitor will display the Attract Mode. During Attract, the T.V. screen will display a play field, score display, and a "ball" rebounding off the playfield borders. The words "CKIDZO By Meadows" are also displayed on the screen.

Coin insertion produces game credit and the players may select either the Two Player Mode or the Four Player Mode by depositing one (25¢) or two (50¢) quarters.

If only one coin is inserted the game allows two players to play the game. When the coin is inserted, the attract display "CKIDZO, By Meadows" will disappear. A goal area and a "face off" box with the ball will appear. The players can now choose the size of goals. When the goals have been selected two players will appear on the field. The two players are square. They have full field travel except each player cannot travel in the opponents goal area. To start the play, the players enter the "face off" box. When the "ball" is hit the box will disappear.

The players can score by moving the "ball" across the field and into the opponents

goal. The "ball" will move only a short distance (approximately 5 inches) each time it's hit. The players can control the direction of the "ball" by hitting different sides or corners of the square.

After a goal has been made, the player's score increases by one, and the "ball" appears in the "face off" box.

The "Speed" buttons can be used to speed up and increase the distance the "ball" travels. The "Speed" button must be pushed before the "ball" is hit.

The players' travel has an inertia property programmed into it. This property does not allow the player to move faster than the "ball". This simulates skating or running action.

The time length of the game is determined by the operator (see "game timer"). The players are aware of the time remaining by a shade that moves down the screen. The game is ended when the shade area reaches the bottom of the T.V. monitor.

If two coins are inserted, four (4) players can play the game.

Game Timer

The time length can be preset by the operator. Ckidzo has an option of 2,4, or 8 minutes. See figure #3 for location of switch.

T.V. Monitor Adjustment

The T.V. monitor adjustments function like those of the home T.V. Set. Refer to

monitor manual for the locations of the following adjustments.

- a. Volume: Adjust the volume to the preference of the location. Keep in mind that the machine will sound louder with the control panel raised.
- b. Brightness: Brightness is adjusted before contrast. Adjust so that raster is visible. The field must be bright so that the black players are visible.
- c. Contrast: Adjust so that the screen images are as bright as possible without blurring.
- d. Vertical Hold: Adjust only if the picture appears to be rolling up or down the screen. Adjust for a stable, centered picture.
- e. Horizontal Hold: Adjust if the picture appears to be shifted off center horizontally, the images are warped, or if the whole picture is broken into diagonal lines.

Paddle Adjustment

Each player has four adjustments. Start the game. Two adjustments are located on the joystick control (see figure #1). Turn #1 pot ears on the control so the players will not go outside the side boundary (boundary nearest to the score). Adjust #2 pot ears so that the white players will not go outside the back boundary nearest it's goal, and the black player will not go inside the whites' goal area.

The other two adjustments are located on the PC board (see figure 3).

Turn the trimmer pots so that the white players will not go inside the black players' goal area, and so that the black players will not go outside the back boundary near their goal.

Turn the 4 trimmer pots nearest the game timer so that the players cannot go outside the side boundary, near the goal selection buttons.

The adjustment made on the PC Board may have affected the adjustment on the joystick control. Re-adjustment may be necessary.

Preliminary Adjustment

The joystick pots need preliminary adjustment if the pots have been replaced. Preliminary adjustments should be done before the joystick is remounted. See figure 4 for exploded view of joystick.

a. Adjusting White Player Joystick: Rotate pots of joystick Counter-Clockwise until the stick is forced to move and the pot will not rotate any further. Now apply slight pressure to the stick and move it in a circular motion. The joystick is ready for mounting in the unit. Wire must be connected to terminals #2 and #3 on the pots.

Coin Acceptor Operation, Adjustment and Maintenance

The detection and rejection of undersized or counterfeit coins are determined by size (both thickness and diameter), weight, and metallic composition.

The transfer cradle (#9 in Figure 5) is used to test both the size and weight of the coin. The quarter must first pivot an "undersize" lever (10) to unlock the transfer cradle and can be returned by actuating the wiper operating lever (17). Oversize diameter coins will fail to pass between the magnet gate (11) and the main channel (5) and will have to be dislodged by actuating the wiper operating lever. Underweight coins will fail to overcome the transfer cradle counterweight and can be returned by operating the wiper lever. A magnet is used to test the metallic composition of the coin. Highly magnetic coins, such

as steel or iron, will be retained by the magnet and can be returned by actuating the wiper operating lever. Coins having comparatively high magnetic properties will be slowed down by the magnet and will drop off the rail short of the Accept entrance and will be returned. Coins having little or no magnetic properties, such as brass or zinc, will pass through the magnetic field so fast they will overshoot the accept entrance and will be returned.

Adjustment

All coin acceptors leave the factory adjusted for maximum performance. If, however, more critical adjustment is desired, or if the unit has been disassembled for cleaning, the following adjustment procedure is suggested.

Kicker and Separator

- a. Set the acceptor on a level surface with the back of the unit facing you (the kicker and separator are on the back).
- b. Loosen the screws holding the kicker (1) and the separator (3) and move both the kicker (2) and the separator (4) as far to the right as they will go. Tighten the screws lightly.
- c. Insert several test coins (both old and new) and note that some are returned by striking the separator.
- d. Loosen the separator screw and move the separator a slight amount to the left. Retighten the screw.
- e. Insert the test coins again, and if some are still returned, repeat Step D until all the coins are accepted.
- f. Loosen the kicker screw and move the kicker a slight amount to the right. Retighten the screw.

- g. Insert the test coins again and, if some of them are returned repeat Step F until all coins are accepted.
- j. Be sure that both screws are tight after the adjustments have been made.

The Magnetic Gate

- a. Set the acceptor with the front of the unit facing you in the test position.
- b. Turn the magnet gate adjustor (12) out (counter-clockwise) until none of the coins will fit through.
- c. With a coin resting in the transfer cradle, turn the adjustor in (clockwise) until the coin barely passes through the magnet gate.
- d. Test this adjustment using several coins, and if any fail to pass through the magnet gate, repeat Step C until all coins are accepted.
- e. Fix the magnet gate adjustor in this position with a drop of glue or Loctite, if necessary.

Acceptor Maintenance

Depending on the environment in which the acceptor is used, periodic preventive maintenance should be performed. The mainplate (5) may be cleaned with any household cleaner. Thorough rinsing and drying are necessary to remove deposits and/or film. Remove all metal particles from the magnet by guiding a screw-lever. Clean the bushings, pivot pins and bushings, and re-assemble.

Testing Components of Game

Buttons & Coin Switch are normally open. When pushed they are closed. The buttons can be by-passed by touching the wires together.

Harness can be tested by an ohm-meter or continuity checker.

Fuses are checked by a visual inspection or continuity checker.

Logic Board & T.V. Monitor can be checked by substitution of a good replacement.

Repair of Logic Board & Monitor should only be serviced by experienced technicians.

No Picture: Check if back of picture tube is lit. If not, inspect fuses, power cord, and power outlet. If these are good and tube is not lit, repair of monitor is necessary. If the tube is lit, check adjustments of brightness and contrast. Test continuity of logic board pin #3 (5th volt dc power supply), and pin #5 (Video output). If all check out, problem is either the logic board or monitor.

No Sound: Check adjustment of volume control on T.V. monitor. Test continuity of logic board pin #17 (audio signal), and monitor pins #5 and #8. Check speaker, logic board, and T.V. monitor.

No Paddles: Check player adjustment. Test continuity of wires, from pots to logic board. The game may not be resetting properly. Check coin switch and wires. Check pots and logic board.

Player Defects: If players appear and are jumpy, oscillating, flickering, or will not stay within its boundaries, pots may need adjustment or replacement.

Game Defects: If game is not operating properly, for example: incorrect scoring

segments missing, erratic ball movement, the likely cause is the logic board.

Ckidzo Speed Ball: Check speed buttons & wires. Check logic board.

REVISIONS

LTR	DESCRIPTION	DATE	APPROVED

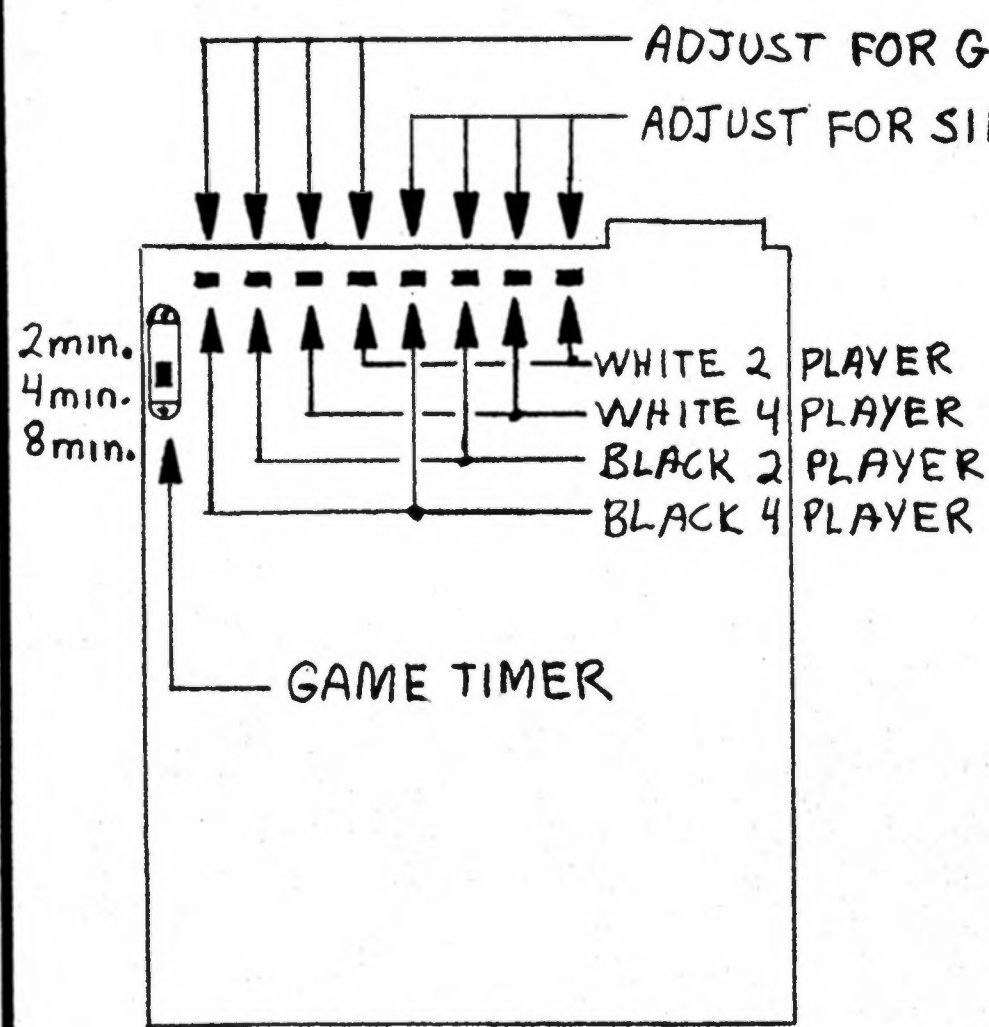

PCB FIGURE 3

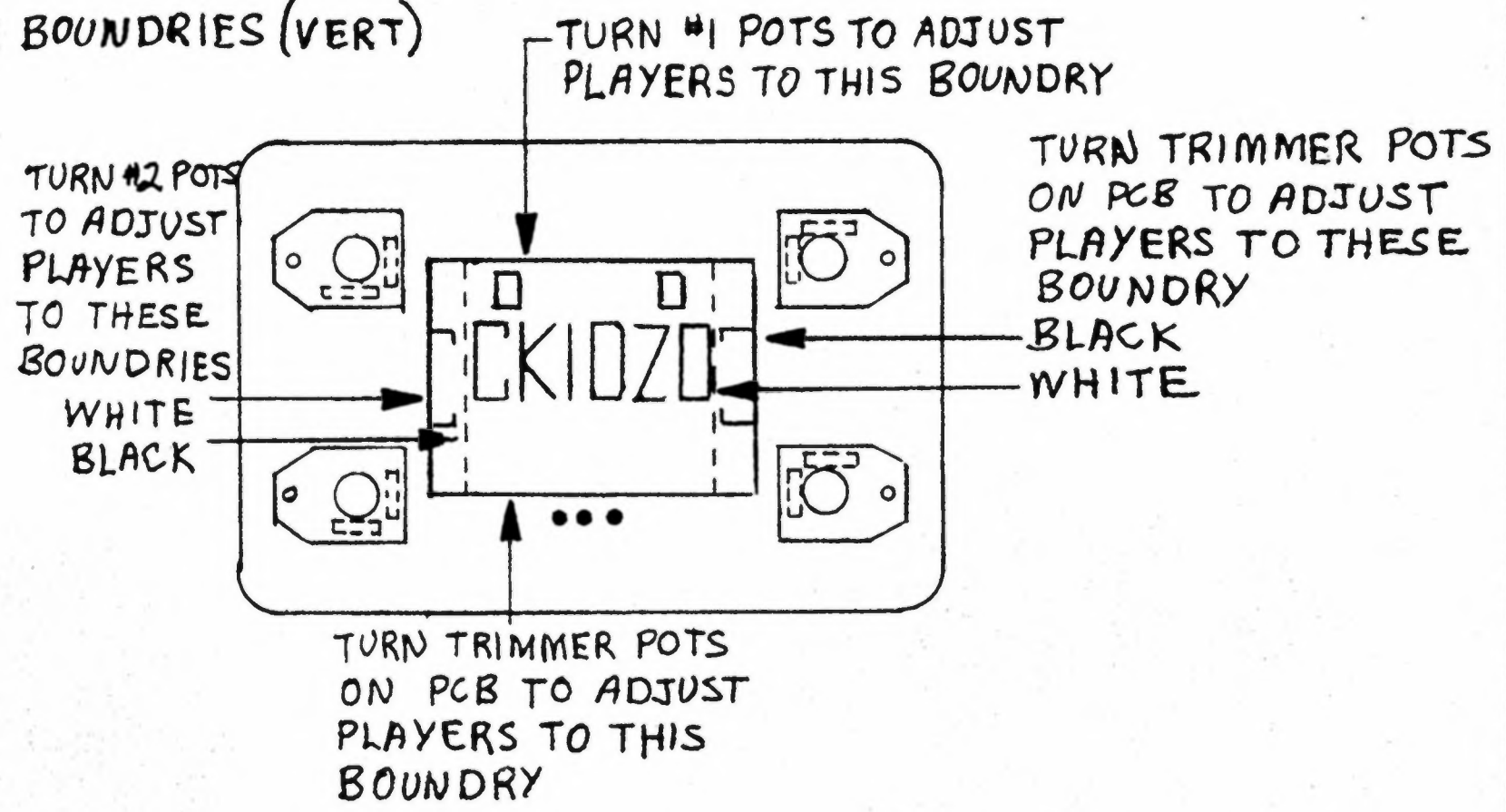

CABINET TOP (TOP VIEW)
FIGURE 2

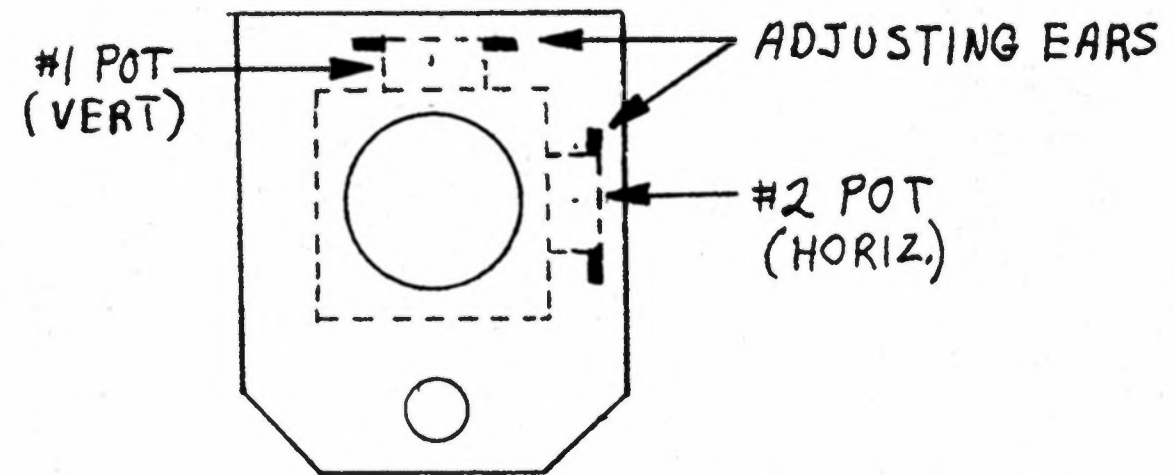

JOYSTICK W/ PLATE (TOP VIEW)
FIGURE 1

TOLERANCES UNLESS OTHERWISE SPECIFIED		MEADOWS GAMES INC		
FRACTIONS	DEC			
±	±	±		CKIDZO PLAYER ADJUSTMENT DIAGRAM
APPROVALS	DATE	SCALE		
DRAWN <i>B.F.</i>	<i>1/20/76</i>	SIZE	DRAWING NO.	
CHECKED			<i>016-0040</i>	
DO NOT SCALE DRAWING			SHEET / OF 1	



REVISIONS			
LTR	DESCRIPTION	DATE	APPROVED

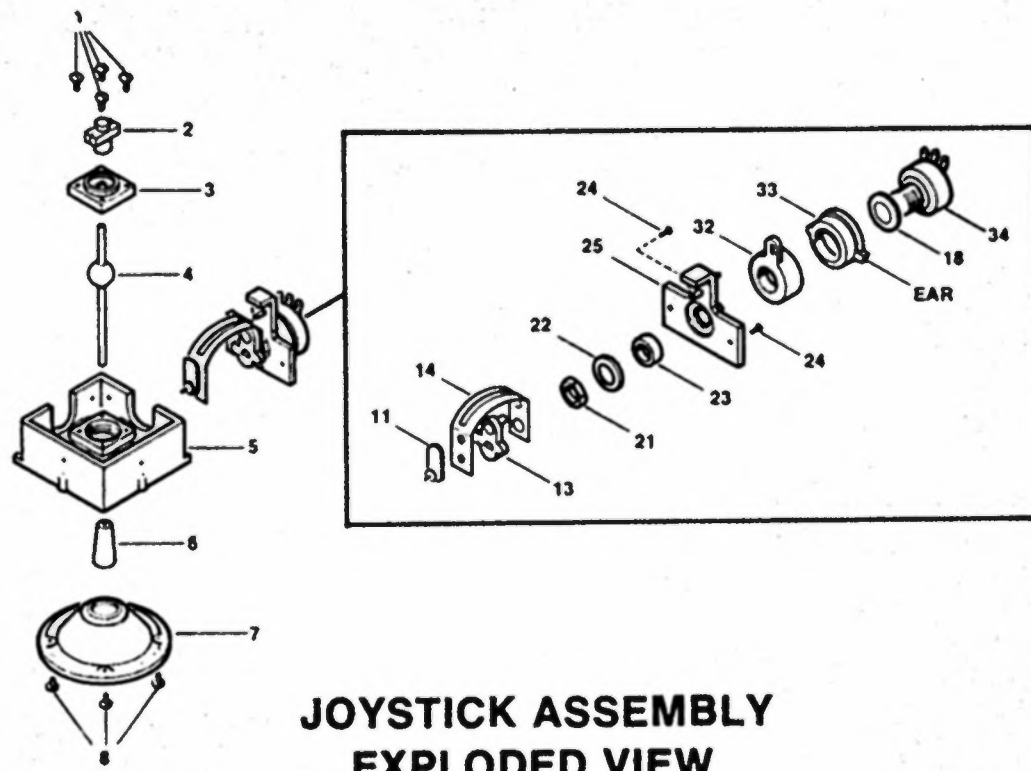

**JOYSTICK ASSEMBLY
EXPLODED VIEW**

FIGURE 4

TOLERANCES UNLESS OTHERWISE SPECIFIED		MEADOWS GAMES, INC.		
FRACTIONS DEC ANGLES		JOYSTICK ASSEMBLY, EXPLODED VIEW		
± ± ±				
APPROVALS	DATE			
DRAWN BF	1/21/76			
CHECKED		SCALE	SIZE	DRAWING NO.
			A	16-0010
DO NOT SCALE DRAWING				SHEET



- 1 KICKER SCREW
- 2 KICKER
- 3 SEPARATOR SCREW
- 4 SEPARATOR
- 5 MAINPLATE ASSEMBLY
- 6 GATE ASSEMBLY
- 7 COVERPLATE ASSEMBLY
- 8 RAIL
- 9 CRADLE ASSEMBLY
- 10 UNDERSIZE LEVER
- 11 MAGNET GATE ASSEMBLY
- 12 MAGNET GATE ADJUSTER SCREW
- 13 LOWER GATE PIVOT SPRING
- 14 UPPER GATE PIVOT SPRING
- 15 GATE PIVOT PIN
- 16 WIPER LEVER SPRING
- 17 WIPER LEVER
- 18 WIPER

REVISIONS			
LTR	DESCRIPTION	DATE	APPROVED

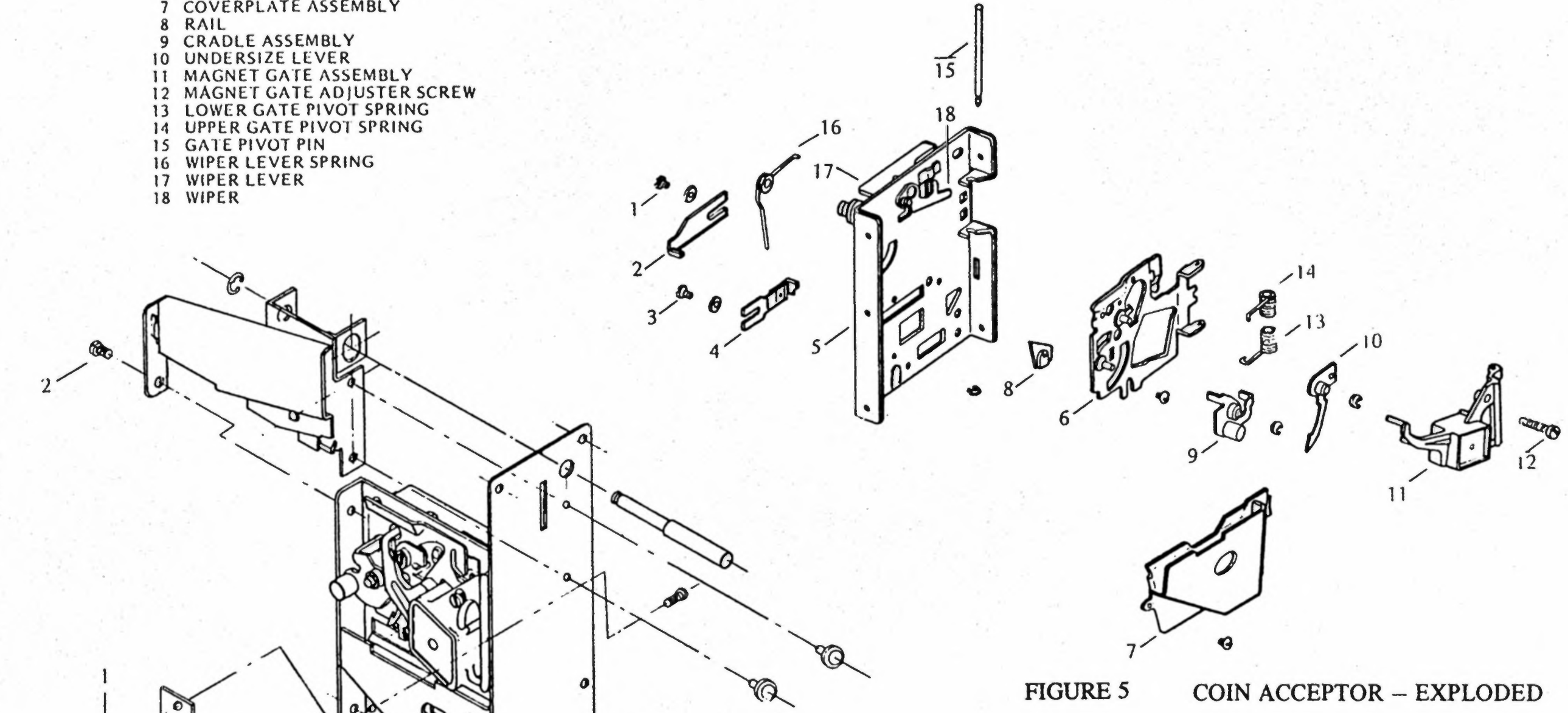

FIGURE 5 COIN ACCEPTOR - EXPLODED

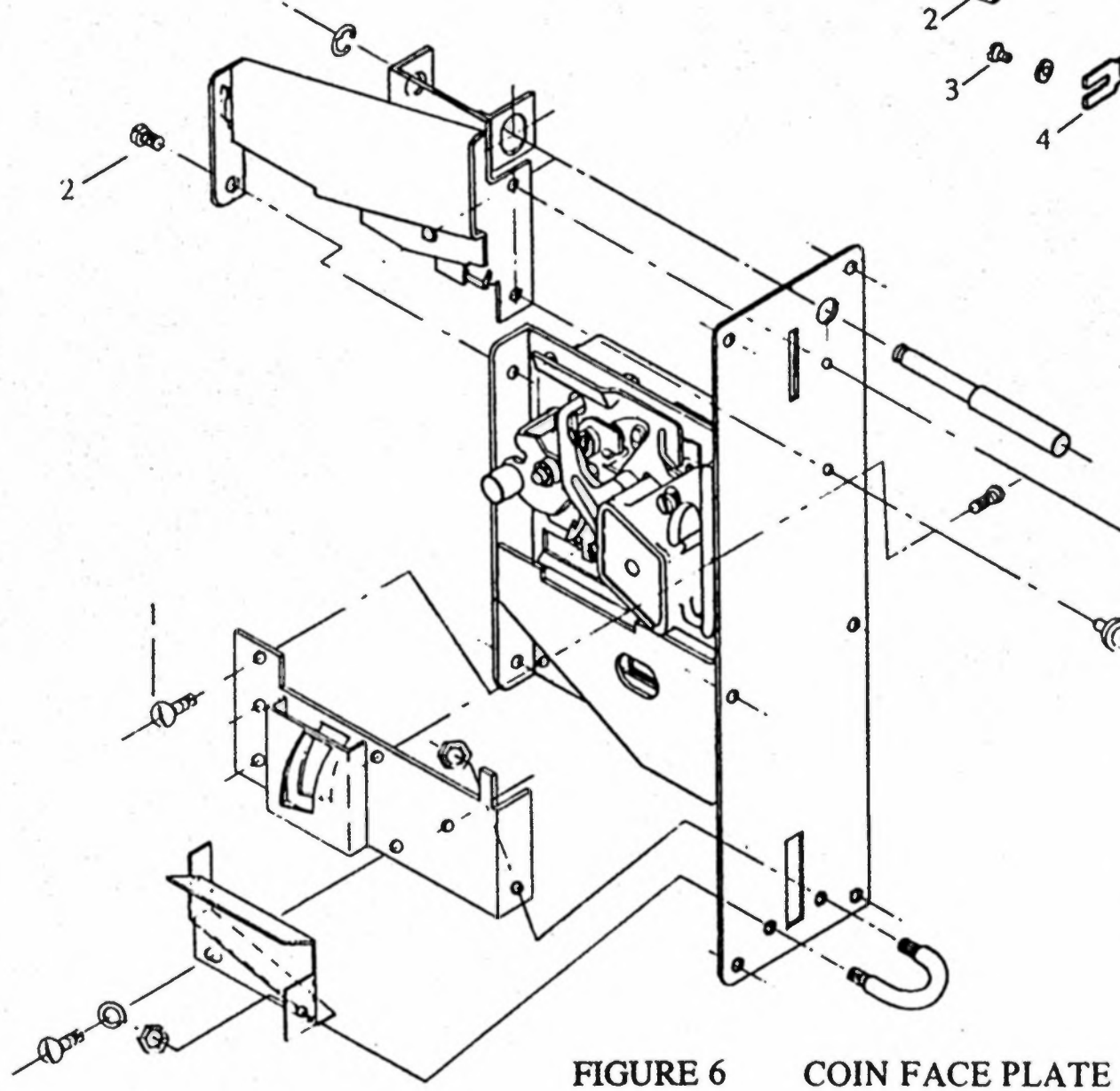
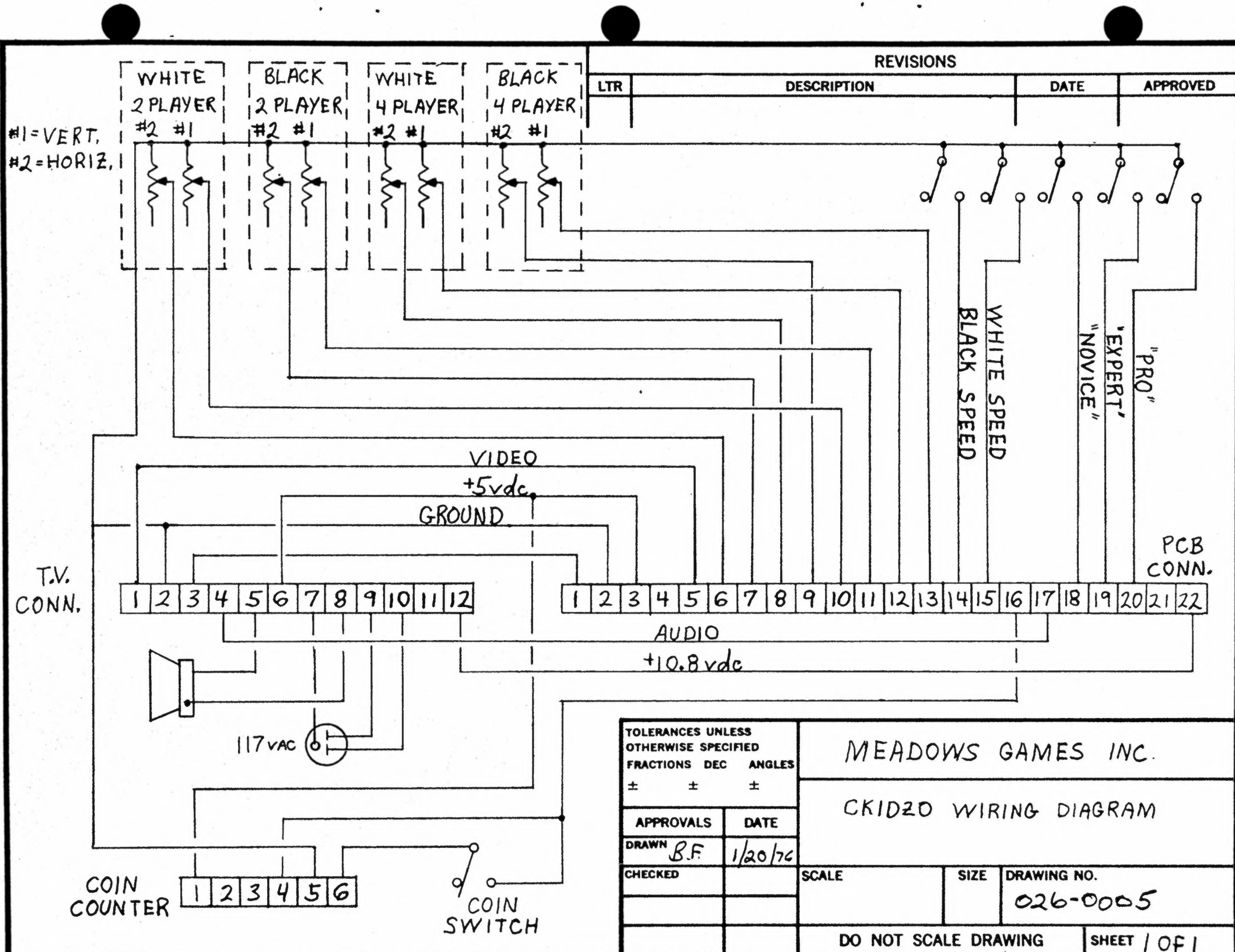

FIGURE 6 COIN FACE PLATE

TOLERANCES UNLESS OTHERWISE SPECIFIED		Meadows Games, Inc.		
FRACTIONS	DEC			
±	±	±		Coin Acceptor Exploded View
APPROVALS	DATE	SCALE		
DRAWN	DATE			
CHECKED		A	16-0009	
DO NOT SCALE DRAWING			SHEET 1 OF 1	





TOLERANCES UNLESS OTHERWISE SPECIFIED		
FRACTIONS	DEC	ANGLES
±	±	±
APPROVALS	DATE	
DRAWN B.F.	1/20/76	
CHECKED	SCALE	SIZE

MEADOWS GAMES INC.		
CKID20 WIRING DIAGRAM		
SCALE	SIZE	DRAWING NO.
		026-0005
DO NOT SCALE DRAWING		SHEET 1 OF 1





MOTOROLA service manual

FILE VP12

DISPLAY PRODUCTS

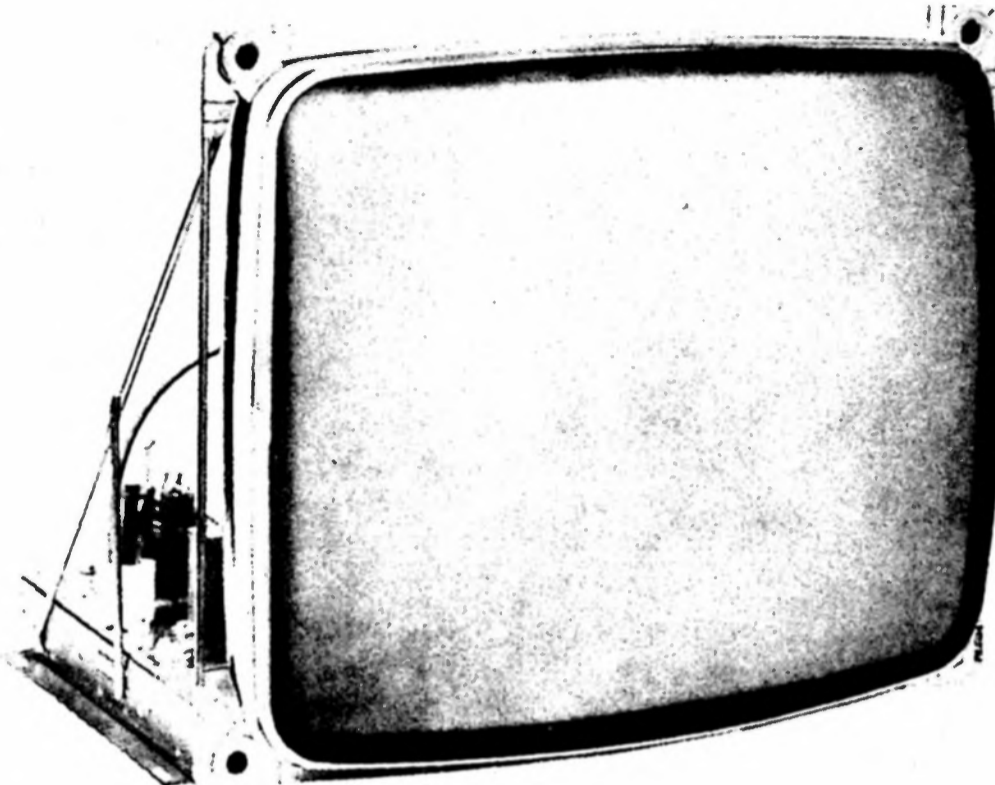

CHASSIS

19VP111
23VP111

MODELS

XM501-10
XM701-10

MODEL XM501-10
XM701-10

CHASSIS 19VP111
23VP111

FILE VP12

MANUAL 68P65130A70-1

GENERAL INFORMATION

These models are transistorized monitors designed for the video game market. They are identical except for the CRT size. See V1 in Replacement Parts List.

Circuitry includes four stages of video amplification, a two stage audio amplifier, sync and deflection circuits and a regulated power supply. An additional 5 volt 3 amp supply is included to power external logic systems. The picture tube is a 114 degree deflection CRT with implosion protection. Composite video is fed to the monitor through a connector mounted on the rear of the chassis.

Rear panel controls include Horizontal Hold, Vertical Hold, Contrast, Brightness, Volume and width controls. Additional service controls are mounted on the plated circuit panel, and are accessible from the rear of the chassis.

The chassis utilizes plug-in etched panel construction with components mounted on the top side and plated wiring on the bottom. Component reference numbers and circuit legend are printed on the board to aid in servicing. Horizontal, vertical output and regulator transistors are mounted on the chassis base which also serves as a heat sink and CRT support.

CAUTION

NO WORK SHOULD BE ATTEMPTED ON ANY EXPOSED MONITOR CHASSIS BY ANYONE NOT FAMILIAR WITH SERVICING PROCEDURES AND PRECAUTIONS.

ELECTRICAL SPECIFICATIONS

Power Rating: 110 watts nominal.
50 watts without 5 volt supply.

Source: 120/240V AC at 50/60Hz
Switch selected.

Video Input: 0.5 to 2.5 volts composite
PP (sync negative).

Audio Output: 5 watts peak

TABLE OF CONTENTS

CHASSIS PARTS LOCATION	8-11
CHASSIS SCHEMATIC DIAGRAM	12
REPLACEMENT PARTS LIST	13, 14
SAFETY WARNING	2
SERVICE NOTES	7
THEORY OF OPERATION	3

SAFETY WARNING

CAUTION: NO WORK SHOULD BE ATTEMPTED ON AN EXPOSED MONITOR CHASSIS BY ANYONE NOT FAMILIAR WITH SERVICING PROCEDURES AND PRECAUTIONS.

1. SAFETY PROCEDURES should be developed by habit so that when the technician is rushed with repair work, he automatically takes precautions.

2. A GOOD PRACTICE, when working on any unit, is to first ground the chassis and to use only one hand when testing circuitry. This will avoid the possibility of carelessly putting one hand on chassis or ground and the other on an electrical connection which could cause a severe electrical shock.

3. Extreme care should be used in HANDLING THE PICTURE TUBE as rough handling may cause it to implode due to atmospheric pressure (14.7 lbs. per sq. in). Do not nick or scratch glass or subject it to any undue pressure in removal or installation. When handling, safety goggles and heavy gloves should be worn for protection. Discharge picture tube by shorting the anode connection to chassis ground (not cabinet or other mounting parts). When discharging, go from ground to anode or use a well insulated piece of wire. When servicing or repairing the monitor, if the cathode ray tube is replaced by a type of tube other than that specified under the Motorola Part Number as original equipment in this Service Manual, then avoid prolonged exposure at close range to unshielded areas of the cathode ray tube. Possible danger of personal injury from unnecessary exposure to X-ray radiation may result.

4. An ISOLATION TRANSFORMER should always be used during the servicing of a unit whose chassis is connected to one side of the power line. Use a transformer of adequate power rating as this protects the serviceman from accidents resulting in personal injury from electrical shocks. It will also protect the chassis and its components from being damaged by accidental shorts of the circuitry that may be inadvertently introduced during the service operation.

5. Always REPLACE PROTECTIVE DEVICES, such as fishpaper, isolation resistors and capacitors and shields after working on the unit.

6. If the HIGH VOLTAGE is adjustable, it should always be ADJUSTED to the level recommended by the manufacturer. If the voltage is increased above the normal setting, exposure to unnecessary X-ray radiation could result. High voltage can accurately be measured with a high voltage meter connected from the anode lead to chassis.

7. BEFORE RETURNING A SERVICED UNIT, the service technician must thoroughly test the unit to be certain that it is completely safe to operate without danger of electrical shock. DO NOT USE A LINE ISOLATION TRANSFORMER WHEN MAKING THIS TEST.

In addition to practicing the basic and fundamental electrical safety rules, the following test, which is related to the minimum safety requirements of the Underwriters Laboratories should be performed by the service technician before any unit which has been serviced is returned.

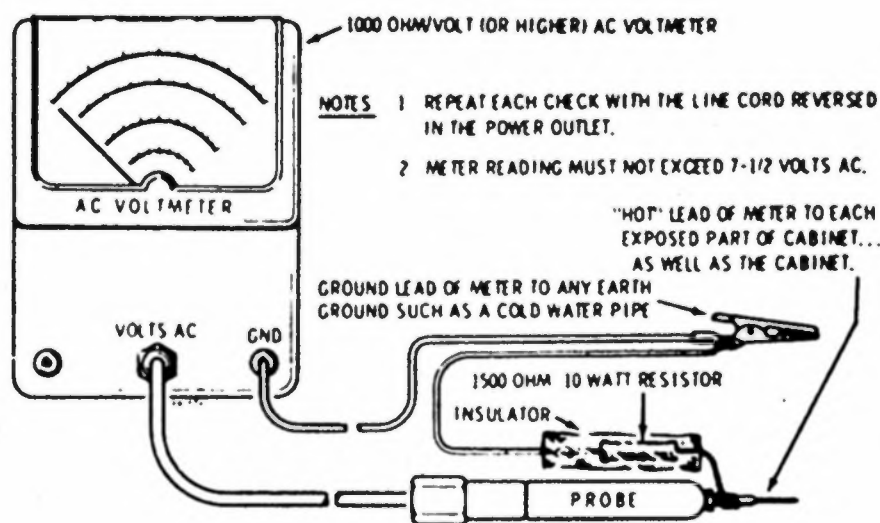

Voltmeter Hook-up for Safety Check.

A 1000 ohm per volt AC voltmeter is prepared by shunting it with a 1500 ohm, 10 watt resistor. The safety test is made by contacting one meter probe to any portion of the unit exposed to the operator such as the cabinet trim, hardware, controls, knobs, etc., while the other probe is held in contact with a good "earth" ground such as a cold water pipe.

The AC voltage indicated by the meter may not exceed 7½ volts. A reading exceeding 7½ volts indicates that a potentially dangerous leakage path exists between the exposed portion of the unit and "earth" ground. Such a unit represents a potentially serious shock hazard to the operator.

The above test should be repeated with the power plug reversed, when applicable.

NEVER RETURN A MONITOR which does not pass the safety test until the fault has been located and corrected.

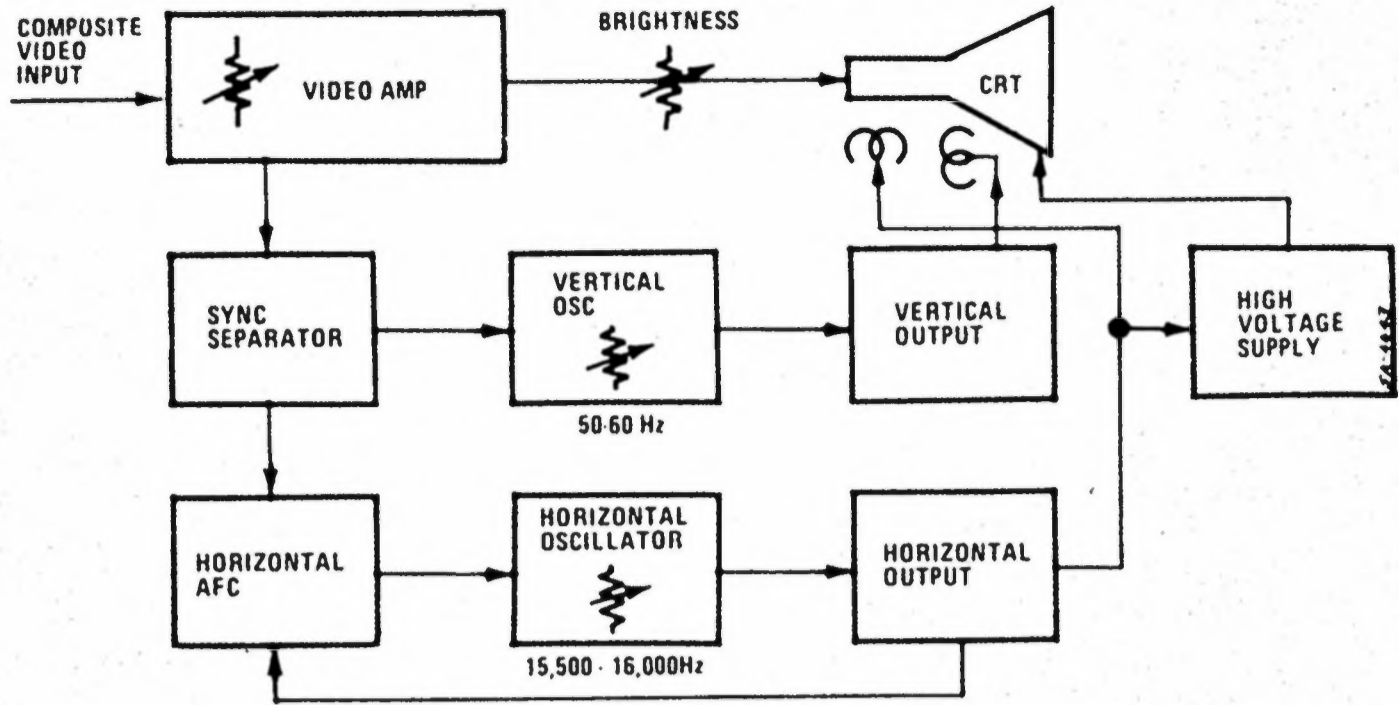

Block Diagram

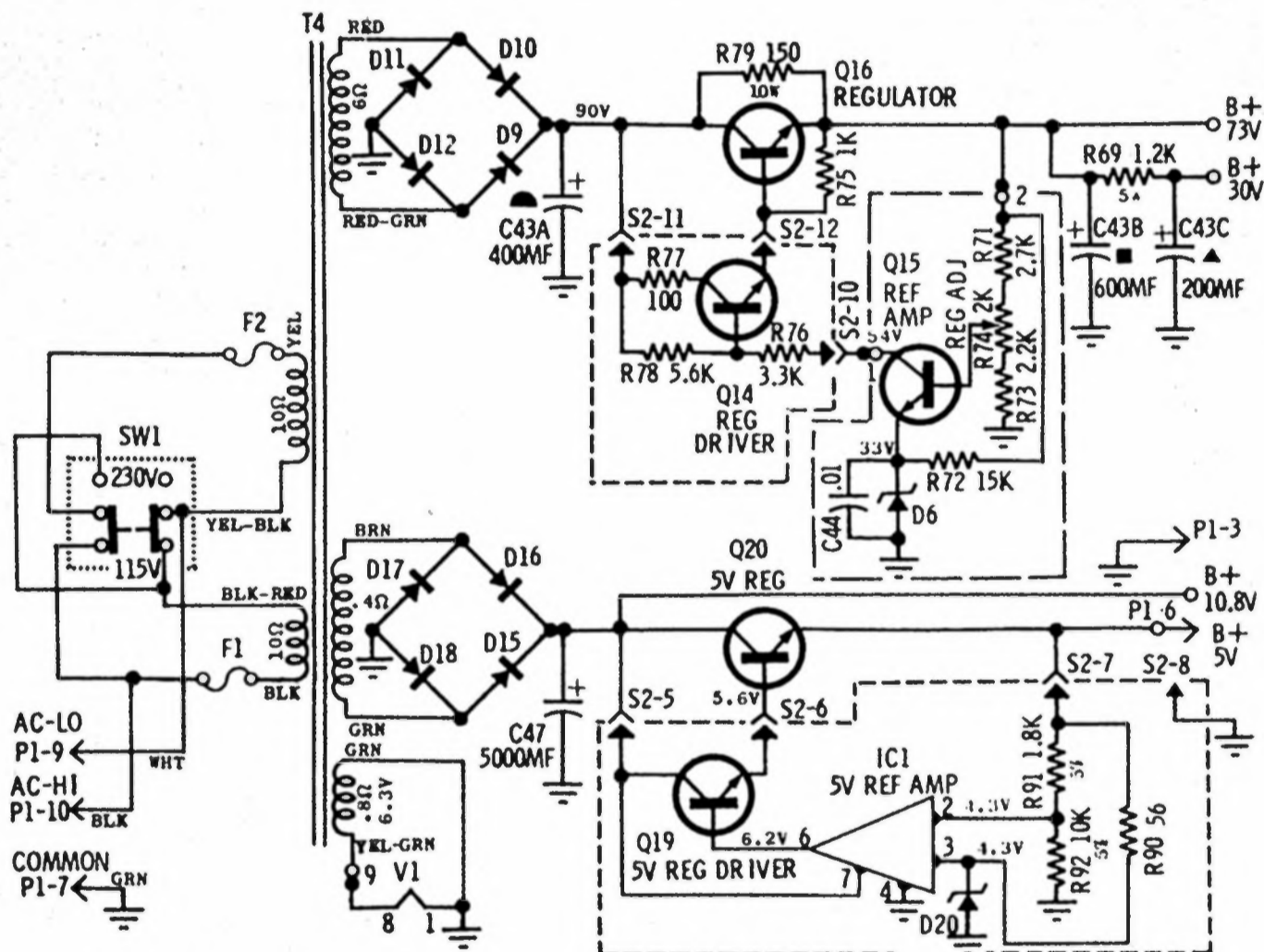

POWER SUPPLY

The power supply is a transformer operated, full wave, regulated supply which maintains constant output voltage with input variations of $\pm 15\%$. A switch (SW1) is provided to allow operation from 115/230 volts, 50/60Hz. The regulator is a series pass circuit. Q16 is the series pass transistor, Q15 the reference amplifier and Q14 the output driver.

The output voltage of the regulator appears at the emitter of Q16. This voltage is divided between R71, R74 and R73. The voltage appearing on the arm of potentiometer R74 is a reference input to the base of Q15.

A temperature compensated zener diode (D6) is used to establish a fixed reference voltage at the emitter of Q15. R72 provides a bias current for D6, establishing its operating point.

An increase in output voltage will result in an increase of voltage at the base of Q15. Since the emitter of Q15 is held at a fixed reference voltage, the change in base voltage will turn Q15 on harder, reducing its collector voltage. This reduces forward bias for Q14 resulting in less emitter current and less base current for Q16. Q16 will conduct less, lowering the output voltage.

R79 provides a shunt current path for Q16 allowing it to run cooler, improving reliability. C44 is an RF noise filter.

A fixed, regulated 5V DC supply is used to power circuits external to the monitor. Its operation is similar to the 73V regulator except for the reference amplifier which is contained in the IC package.

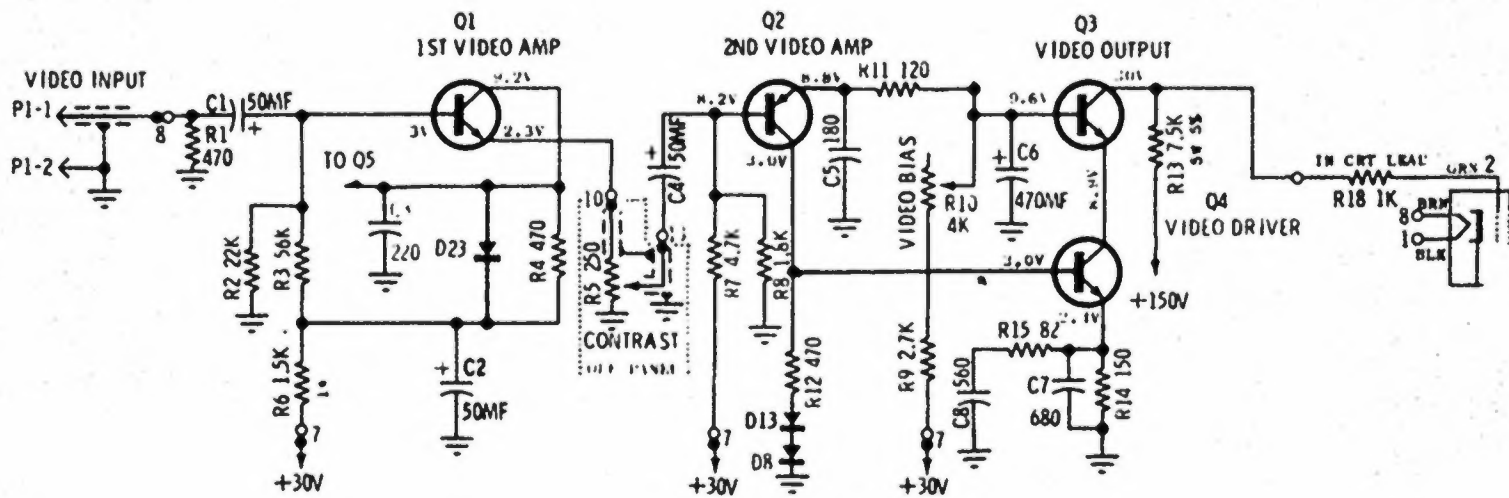

VIDEO AMPLIFIER

The video amplifier has four stages incorporating devices Q1, Q2, Q3 and Q4. The first stage, Q1, functions as an emitter follower. The low output impedance of the first stage permits use of a low resistance contrast control which furnishes flat video response over its entire range without the need for compensation. The collector output of Q1 is used to drive the sync separator. C3 provides high frequency roll off to limit the collector output to the bandwidth required to pass synchronization signals. Q2 is a common emitter stage and is directly coupled to Q4. Q3 and Q4 are connected in a cascode configuration. This common emitter-common base connection greatly reduces the effect of Miller capacity compared with a conventional single transistor video output stage. C6 provides a ground for video at the base of Q3, the grounded base transistor of the video output cascode pair. Diodes D13 and D8 provide temperature compensation for the video output stages, and diode D23 protects Q1 from transients.

The video bias control R10, is used to set the quiescent collector voltage of Q3. C5, C7, C8 and R15 are used for high frequency compensation. The video amplifier output is direct coupled to the control grid of the CRT through R18 which is used to isolate Q3 from transients that may occur as a result of CRT arcing.

SYNC SEPARATOR

The sync separator employs a single stage, Q5, to recover sync from the composite video signal. A single stage sync separator is adequate due to the high impedance of the following stages. The video input to the sync separator is black positive. C11 is charged by the peak base current that flows when the positive peak of the input takes Q5 to saturation. This charge depends on the peak to peak input to Q5 and thus makes the bias for Q5 track the amplitude of the input signal. As a result Q5 amplifies only the positive peaks of the input signal. The initial bias current through R24 sets the clipping level. R98 is used for transient protection.

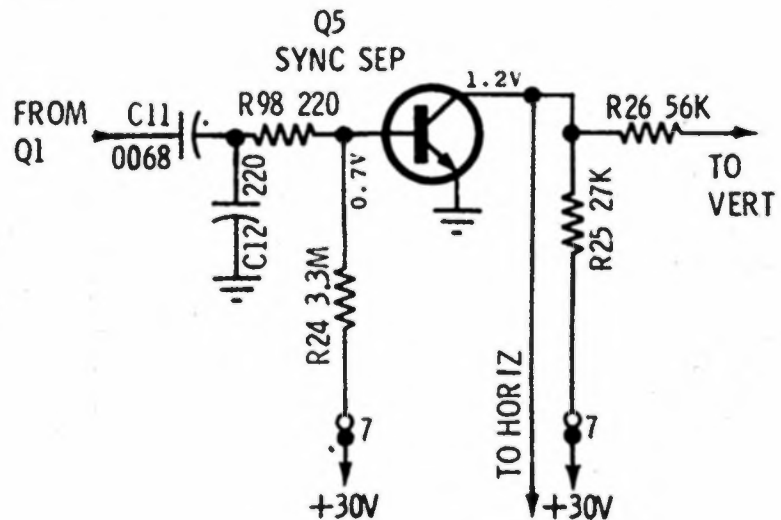

PHASE DETECTOR

The Phase Detector consists of two diodes in a keyed clamp circuit. Two inputs are required to generate the required output, one from the sync separator and one from the horizontal deflection system. The required output must be of the correct polarity and amplitude to correct phase differences between the input sync and the horizontal time base. The horizontal collector pulse is integrated into a sawtooth by R45 and C15. During sync time both diodes in D7 conduct, shorting C15 to ground.

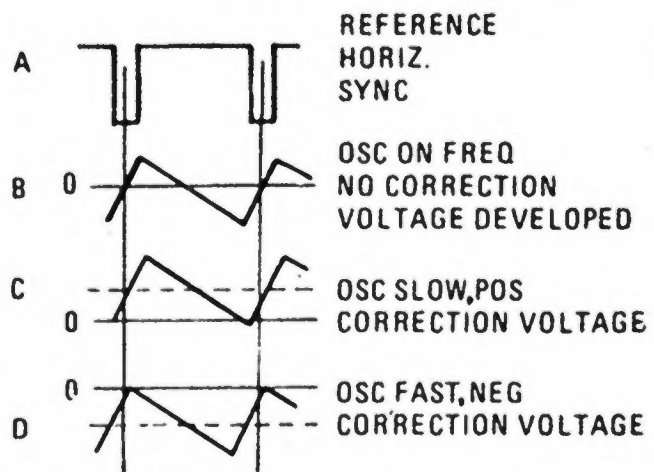

The sawtooth on C15 is thus clamped to ground at sync time. If the horizontal time base is in phase with the sync, the sync pulse will occur when the sawtooth is passing through its AC axis and the net charge on C15 will be zero. (Figure B). If the horizontal time base is lagging the sync, the sawtooth on C15 will be clamped to ground at a point negative from the AC axis. This will result in a positive DC charge on C15. (Figure C). This is the correct polarity to cause the horizontal oscillator to speed up to correct the phase lag.

Likewise, if the horizontal time base is leading the sync, the sawtooth on C15 will be clamped at a point positive from its AC axis, resulting in a net negative charge on C15 which is the required polarity to slow the horizontal oscillator (Figure D). R30, C17, C16 and R32 comprise the phase detector filter. The bandpass of this filter is chosen to provide correction of horizontal oscillator phase without ringing or hunting. Capacitor C23 times the phase detector for correct centering of the picture on the raster.

HORIZONTAL OSCILLATOR

Q6 is employed in a modified type of Hartley oscillator. The operating frequency of this oscillator is sensitive to its base input voltage. This permits control by the output of the phase detector and also by the setting of the horizontal hold control, R34. The horizontal hold range is set by adjustment of the core of L1.

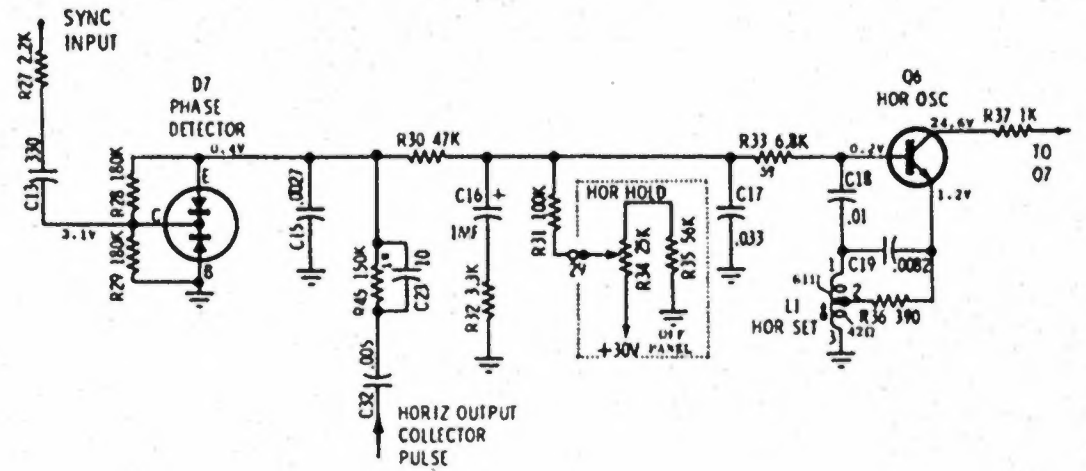

PULSE SHAPER & HORIZONTAL DRIVER

Q7 is used as a buffer stage between the horizontal oscillator and horizontal driver. It provides isolation for the horizontal oscillator as well as a low impedance drive for the horizontal driver. R38 and C20 form a time constant which shapes the oscillator output to the required duty cycle (approximately 50%), to drive the horizontal output circuitry. The horizontal driver stage, Q8 operates as a switch to drive the horizontal output transistor through T1. Because of the low impedance drive and fast switching times furnished by Q7, very little power is dissipated in Q8. C21 and R42 provide damping to suppress ringing of the primary of T2 when Q8 goes into cutoff.

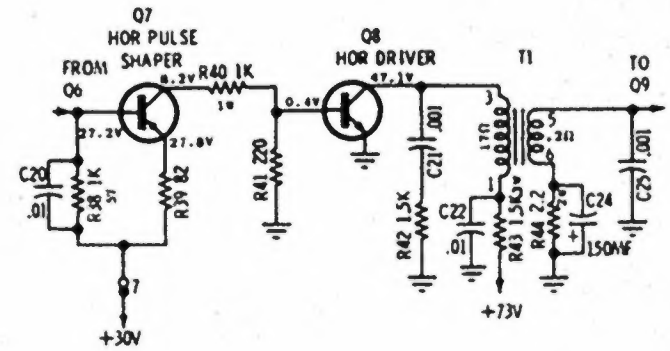

HORIZONTAL OUTPUT

The secondary of T1 provides the required low drive impedance for Q9. R44 and C24 form a time constant for fast turn-off of the base of Q9. Q9 operates as a switch which, once each horizontal period, connects the supply voltage across the parallel combination of the horizontal deflection yoke and the primary of T2. The required sawtooth of deflection current through the horizontal yoke is formed by the L-R time constant of the yoke and output transformer primary. The horizontal retrace pulse charges C27 through D2 to provide operating voltage for G2 of the CRT. Momentary transients at the collector of Q9, should they occur, are limited to the voltage on C27 since D2 will conduct if the collector voltage exceeds this value.

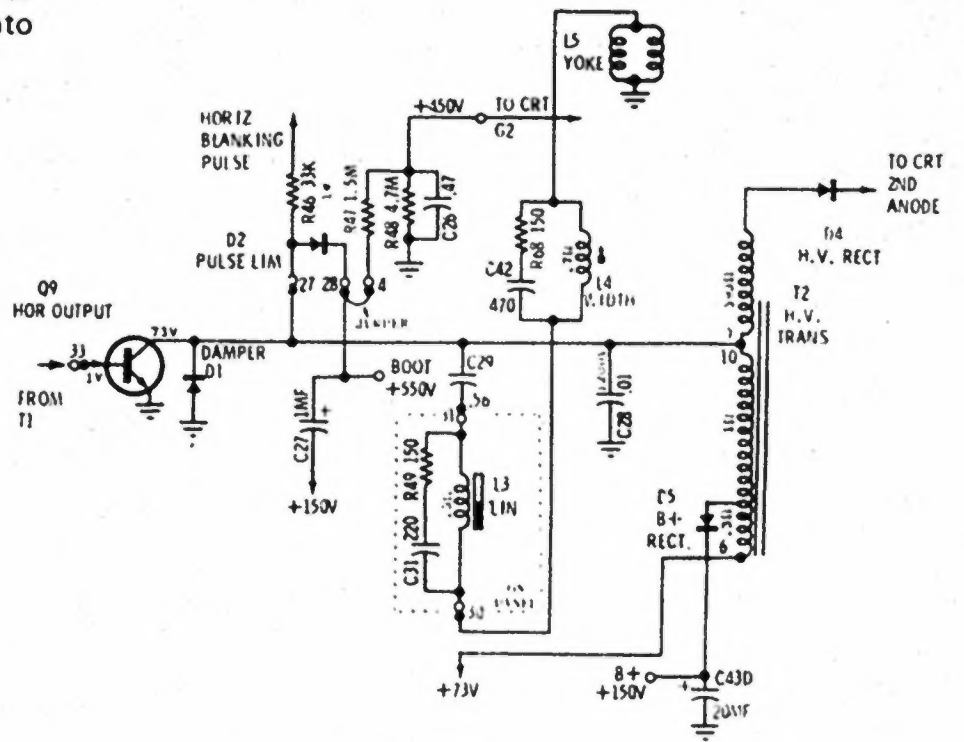

The damper diode, D1, conducts during the period between retrace and turn on of Q9. C28 is the retrace tuning capacitor. C29 blocks DC from the deflection yoke. L3 is a magnetically biased linearity coil which shapes deflection current for optimum trace linearity. L4 is a series width control. C31 and R49, C42 and R68 are damping network components for the linearity and width controls. C43D is charged through D5 developing the video supply voltage.

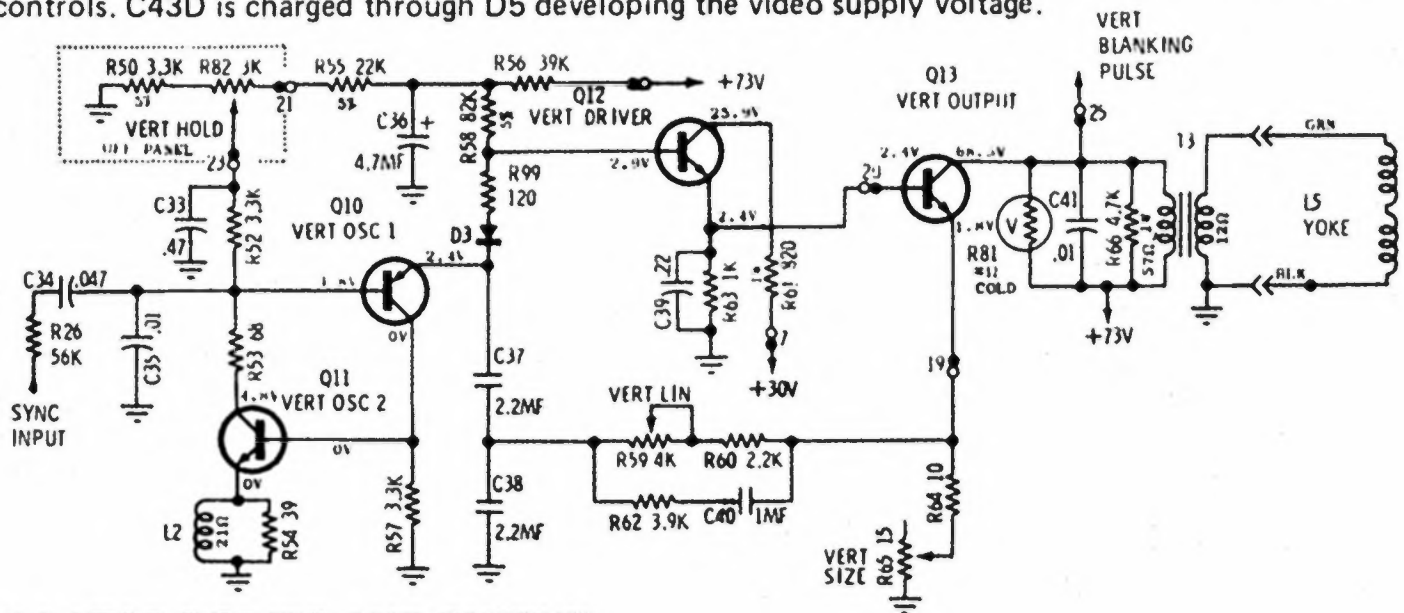

VERTICAL OSCILLATOR DRIVER AND OUTPUT

Sync from the collector of Q5 is integrated by R26 and C35. Q10 and Q11 are connected as a regenerative switch. The series combination of C37 and C38 charges through R58, R56 and D3 until Q10 turns on. This occurs when the emitter of Q10 exceeds its base voltage and causes current to flow into the base of Q11, turning that device on. When Q10 and Q11 conduct,

C37 and C38 are discharged to nearly zero. Q10 and Q11 then shut off and the cycle repeats. The setting of R82 determines the repetition rate of the charge and discharge of C37 and C38. The waveform generated is a positive going ramp or sawtooth with a fast retrace to zero. D3 provides a small incremental voltage above ground to overcome the forward sawtooth to a low impedance drive for Q13.

T3 matches the collector of Q13 to the vertical yoke. When Q13 is cut off during vertical retrace, a high voltage pulse is developed across the primary of T3. To limit this pulse to a safe value a varistor, R81, is connected across the primary. R66 and C41 provide damping to shape the collector pulse so it may be used for retrace blanking. Since the primary impedance of T3 decreases with current, the degree to which the primary shunts the reflected load impedance varies with collector current. This would result in severe vertical non-linearity unless some compensation is employed.

Resistors R59 and R60 couple the emitter voltage of Q13 to the junction of C37 and C38. Since this path is resistive, the waveform coupled back will be integrated into a parabola by C38. This results in a pre-distortion of the drive sawtooth as shown in Figure C. This is done to compensate for the non linear charging of C37 and C38 and the changing impedance of the primary of T3. An additional feedback path through R62 and C40 serves to optimize the drive waveshape for best linearity.

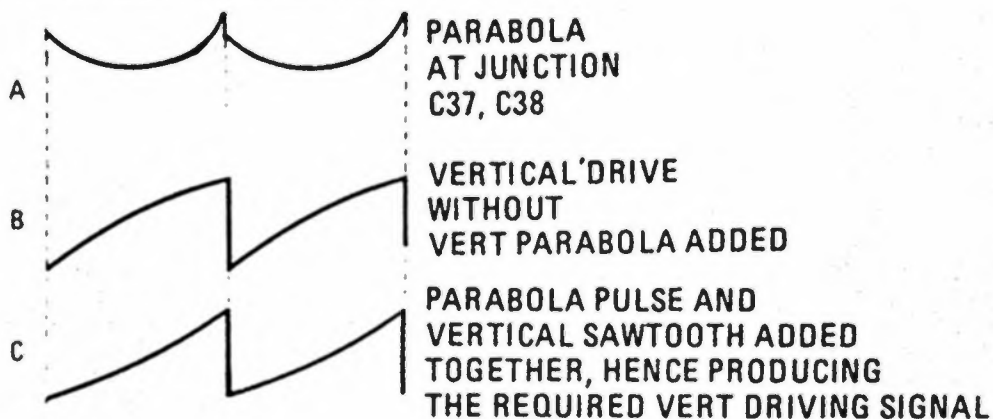

RETRACE BLANKING

Both vertical and horizontal retrace blanking are provided by positive pulses applied to the CRT cathode. The collector pulse from the horizontal output transistor is placed across R23 through R46. The vertical collector voltage is differentiated by C30 to remove the sawtooth portion of the waveform. The remaining pulse appears across R23. The mixed vertical and horizontal pulses on R23 are coupled to the CRT cathode by C10.

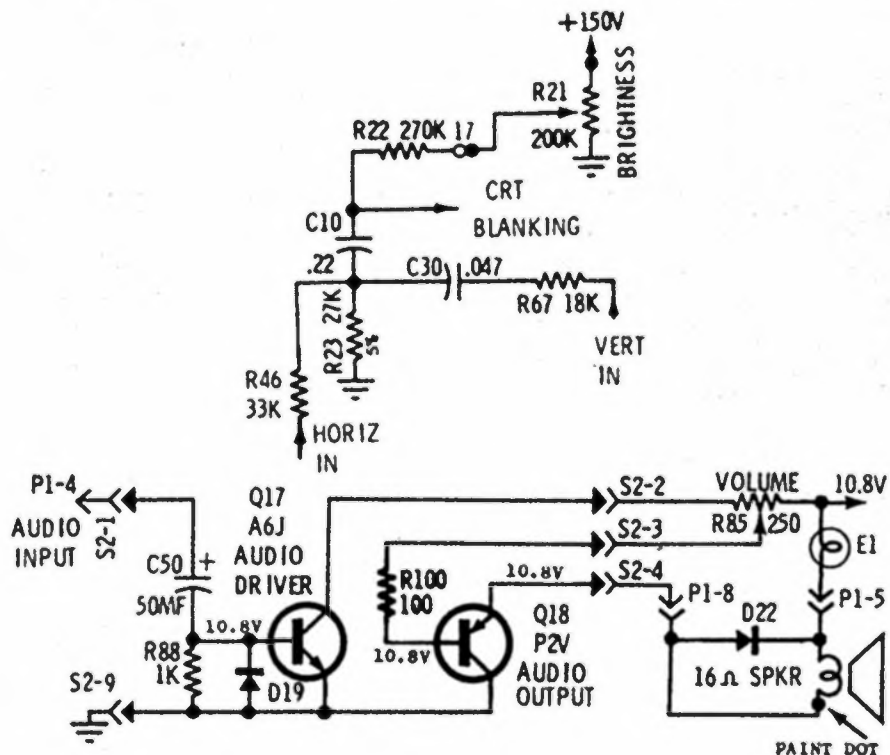

AUDIO AMPLIFIER

Q17 and Q18 form a DC coupled "switching tone burst amplifier". An input signal biases Q17 on, in turn driving Q18 into conduction. When the signal is removed both stages return to a quiescent mode. Coupling capacitor C50, diode D19 and resistor R88 establish a bias voltage which is signal dependent. Volume control R85 sets the peak to peak level for the output stage.

Lamp E1 serves to protect the speaker if the audio output transistor fails, it also protects the transistor should the speaker leads be shorted.

Diode D22 (on early models) polarizes the speaker insuring proper installation. If it is installed wrong, little or no audio will be developed.

SPOT KILLER

Normally Q21 is not conducting and capacitor C51 is charged to the supply voltage. When the monitor is turned off, C51 discharges through R96 turning the transistor on. It in turn removes the positive potential from the brightness control connecting the CRT cathode to ground, causing the tube to conduct hard, discharging the high voltage.

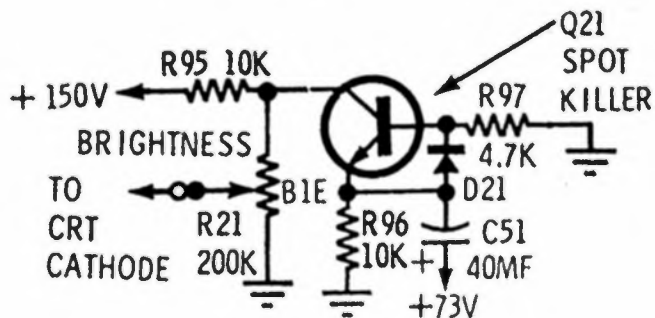

PANEL REMOVAL/INSTALLATION

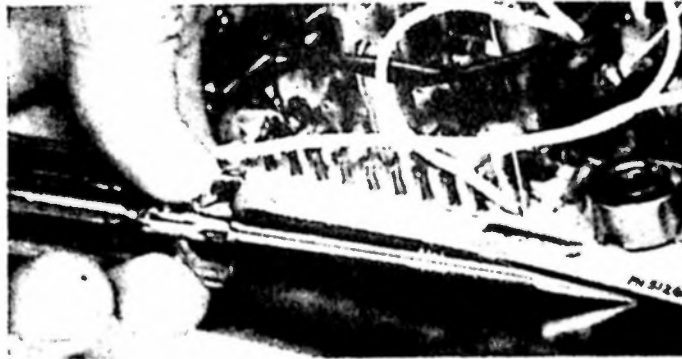
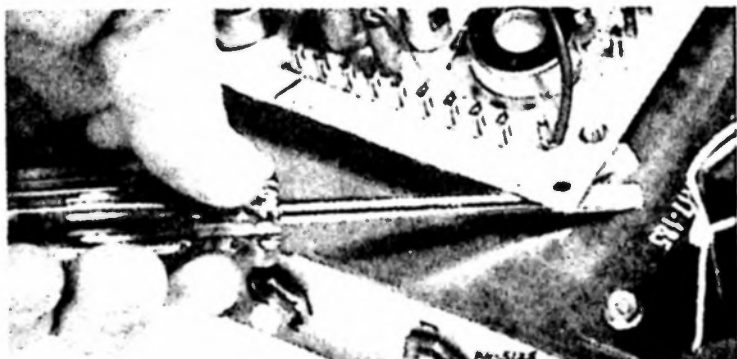

To prevent damage to the board or foil when removing the circuit panel it may be necessary to pry up slowly, IN STAGES around the edges as shown. Start at one corner and move all around the board keeping the screw driver tip against the chassis. When installing, apply pressure at the edges near the pins. Do not force down on the components.

SERVICE NOTES

CIRCUIT TRACING

Component reference numbers are printed on top and bottom of the plug-in circuit board to facilitate circuit tracing. In addition, control names and board terminal numbers are also shown and are referenced on the chassis schematic diagram in this manual.

Transistor elements are identified as follows:

E — emitter, B — base, and C — collector.

COMPONENT REMOVAL

Removing components from the etched board is facilitated by the fact that the circuitry (plating) appears on one side of the board only and the component leads are inserted straight through the holes and are not bent or crimped.

It is recommended that a solder extracting gun be used to aid in component removal. An iron with a temperature controlled heating element would be desirable since it would reduce the possibility of damaging the board due to over-heating.

The nozzle of the soldering gun is inserted directly over the component lead and when sufficiently heated, the solder is drawn away leaving the lead free from the copper plating. This method is particularly suitable in removing multi-terminal components.

REGULATOR ADJUSTMENT

NOTE: Misadjustment of the low voltage regulator, or the horizontal oscillator may result in damage to the Horizontal Output Transistor or pulse limiter diode. The following procedures are recommended to insure reliable operation.

1. Connect monitor to AC line supply. Adjust supply to 120 volts (240 on some models).

2. Apply test signal to proper input. Signal should be of same amplitude and sync rate as when monitor is in service.

3. Adjust vertical and horizontal oscillator controls until display is synced.

4. Connect a DC digital voltmeter or other precision accuracy voltmeter to the emitter of the regulator output transistor, (or any 73 volt test point).

5. Adjust the regulator control R74, on circuit board for an output of 73 volts. Do not "run" the regulator control through its range or damage to the monitor may result.

6. When adjustment is complete, the AC line supply can be varied between 105 and 130 volts to check for proper regulator operation. With regulator operating properly, changes in display size should be negligible.

HORIZONTAL OSCILLATOR ADJUSTMENT

1. Set the horizontal hold potentiometer to mid-range (R34).

2. Adjust core of horizontal hold coil L1 until the horizontal blanking lines are vertical.

3. Rotate potentiometer R34 through its full range. Display should go out of sync in each direction and hold in sync at the center of its range. Retouch L1 as necessary to center the hold range.

VIDEO AMPLIFIER BIAS ADJUSTMENT

Adjust video bias control R10 for 30 volts DC on collector of video output transistor Q3 with no signal input.

Disconnect cable from video input jack if necessary to eliminate noise.

POWER TRANSISTOR REPLACEMENT

When replacing any "plug-in" transistor, i.e., the horizontal or vertical output, please observe the following precautions:

1. The transistor sockets are not "Captive", that is, the transistor mounting screws also secure the socket. When installing the transistor, the socket must be held in its proper location. This location is indicated by flanges on the socket which fit into the heat sink.

2. When replacing the output transistors, silicone grease (Motorola Part No. 11M490487) should be

applied evenly to both sides of the mica insulator.

3. All transistor mounting screws must be tight before applying power to the receiver. This insures proper cooling and electrical connections.

NON-COMPLIANCE WITH THESE INSTRUCTIONS CAN RESULT IN FAILURE OF THE TRANSISTOR AND/OR ITS RELATED COMPONENTS.

NOTE: Use caution when tightening transistor mounting screws. If the screw threads are stripped by excessive pressure, a poor electrical and mechanical connection will result.

CRT REPLACEMENT

Use extreme care in handling the CRT as rough handling may cause it to implode due to atmospheric pressure. Do not nick or scratch glass or subject it to any undue pressure in removal or installation. Use goggles and heavy gloves for protection.

1. Discharge CRT by shorting 2nd anode to ground. Remove CRT socket, yoke and 2nd anode lead.

2. Remove CRT from chassis by removing four screws at corners.

PANEL CONNECTOR CONTACT REMOVAL

Contacts can be removed from the multipin panel connector by using extractor tool, Part No. 66P65173A47. Insert the tool over contact and seat fully. Tool will release contact. Pull contact out from wired side.

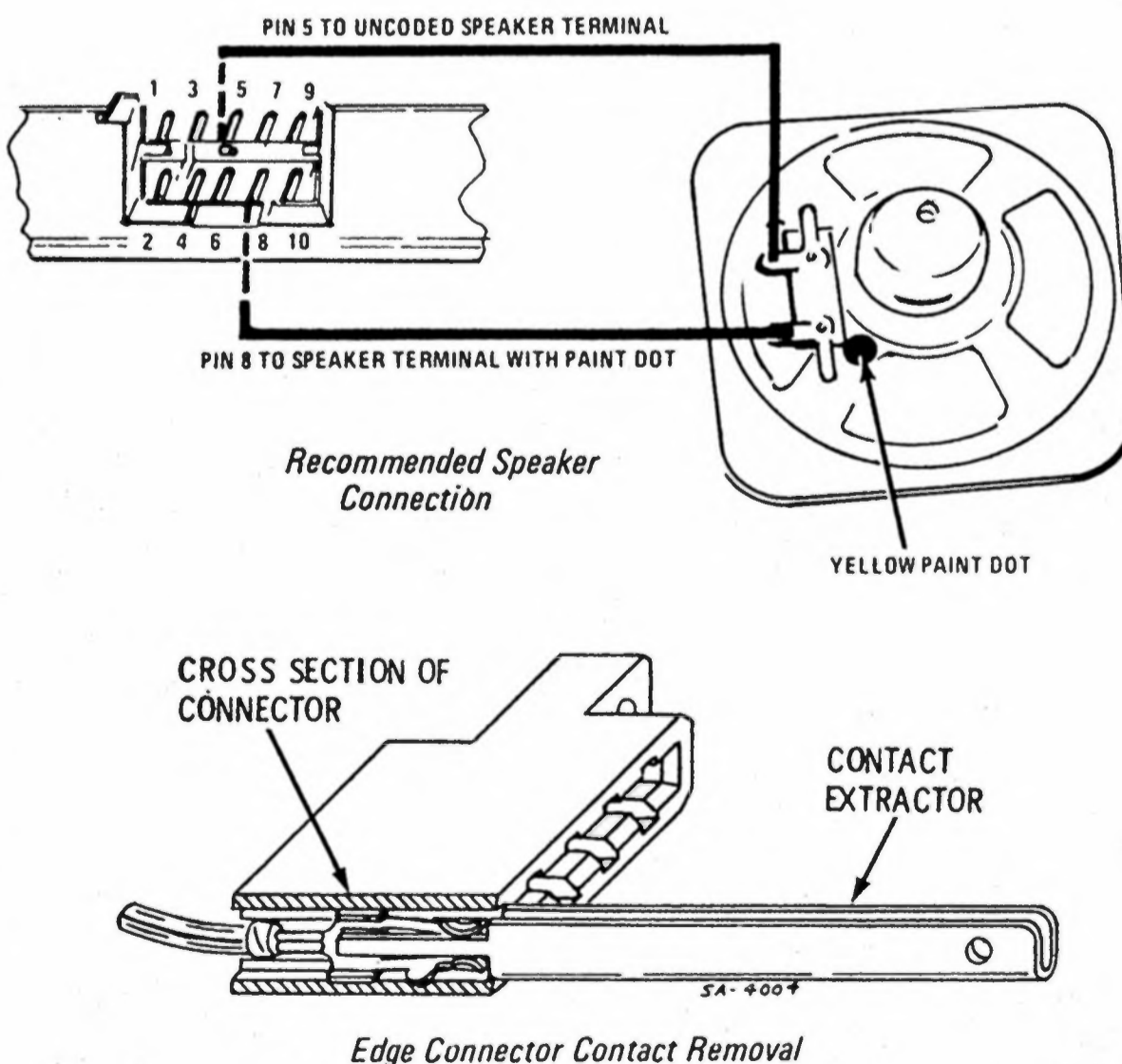

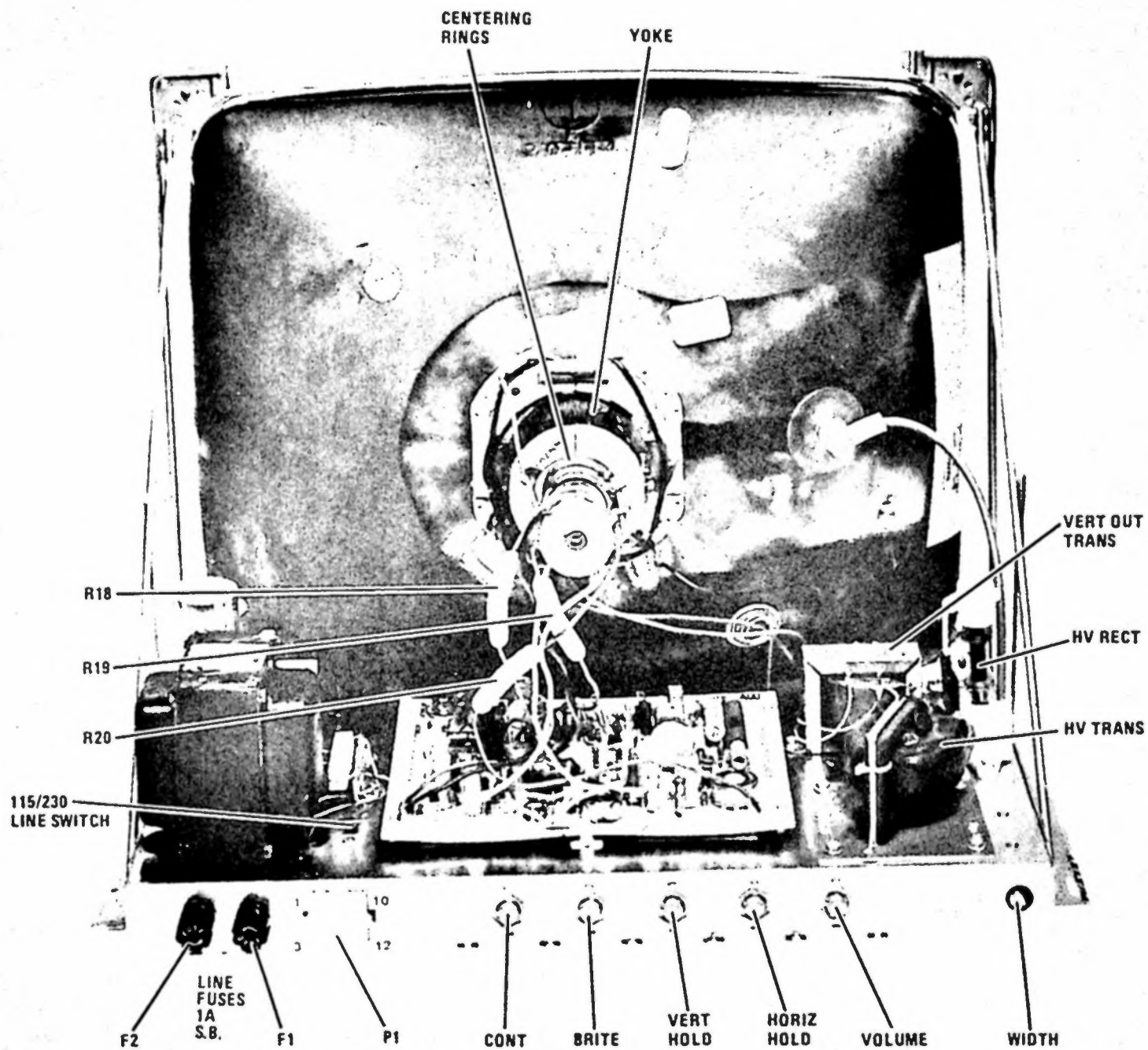

Chassis Component Location Rear View

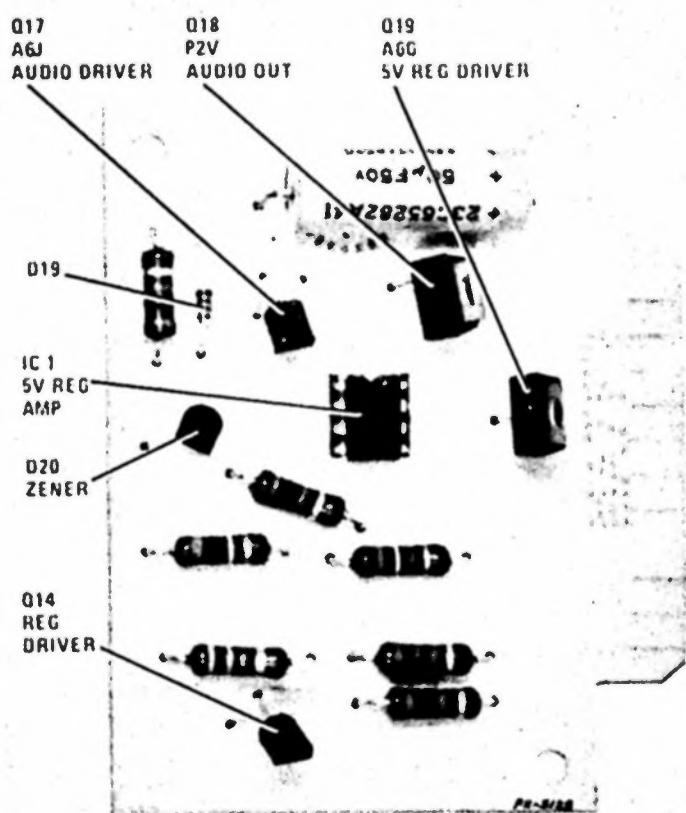

Top View

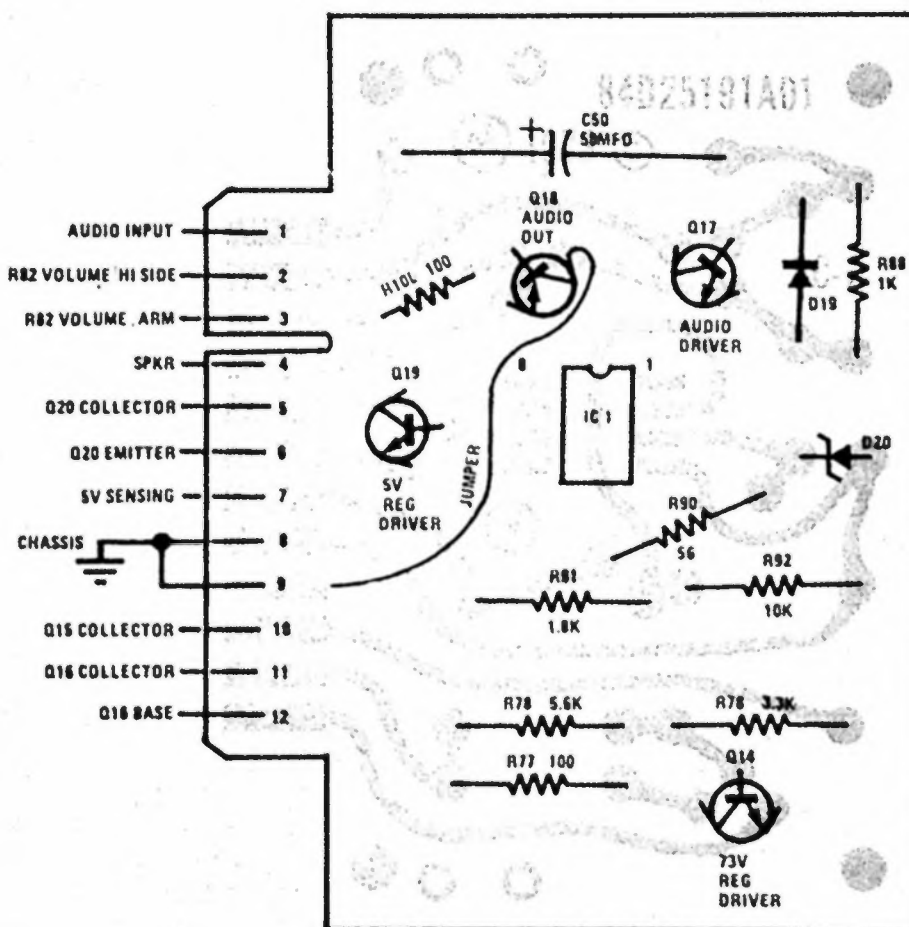

Circuit Side

Power, Audio Panel Component Location

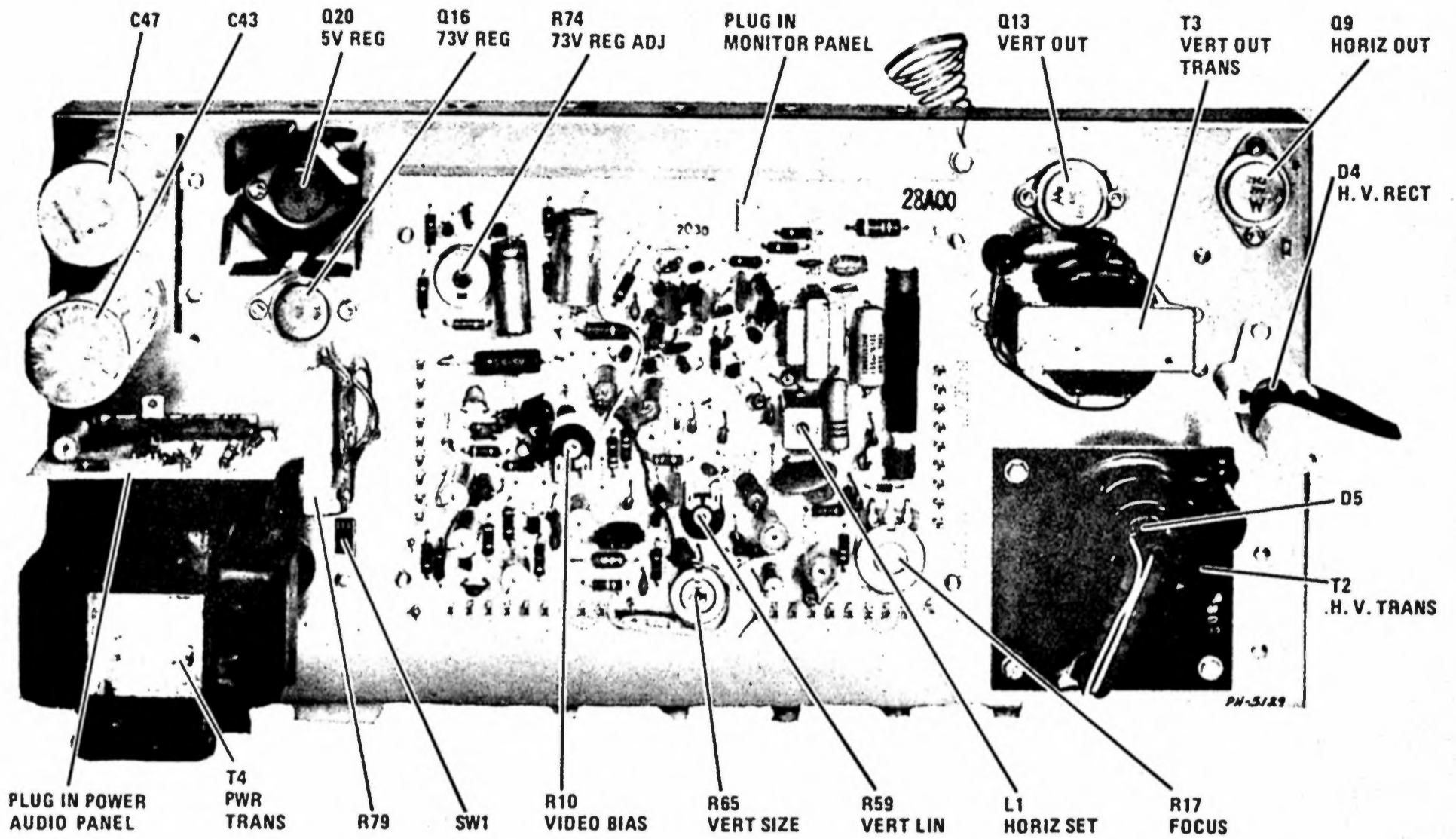

Chassis Component Location Top View

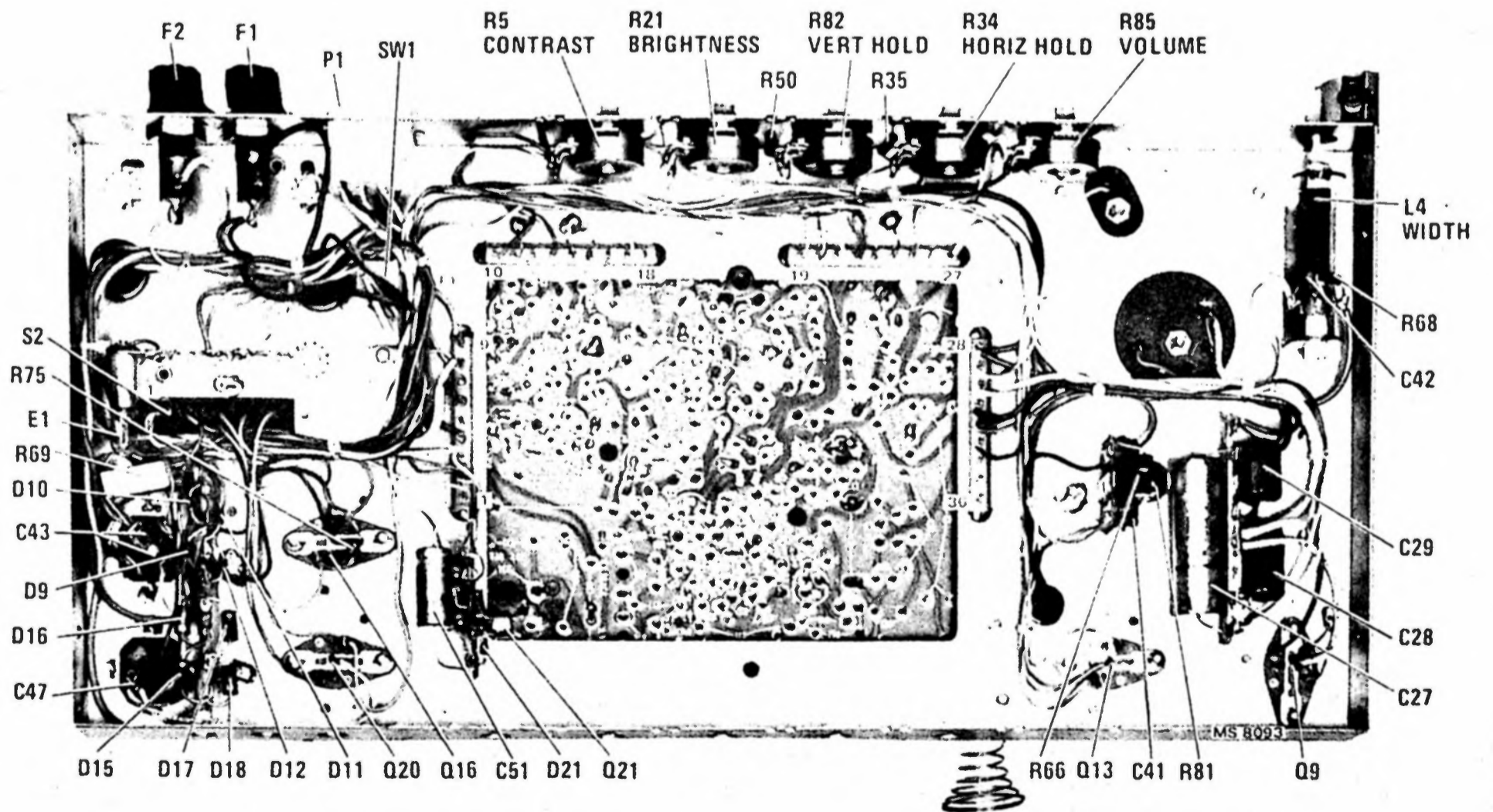

Chassis Component Location Bottom View

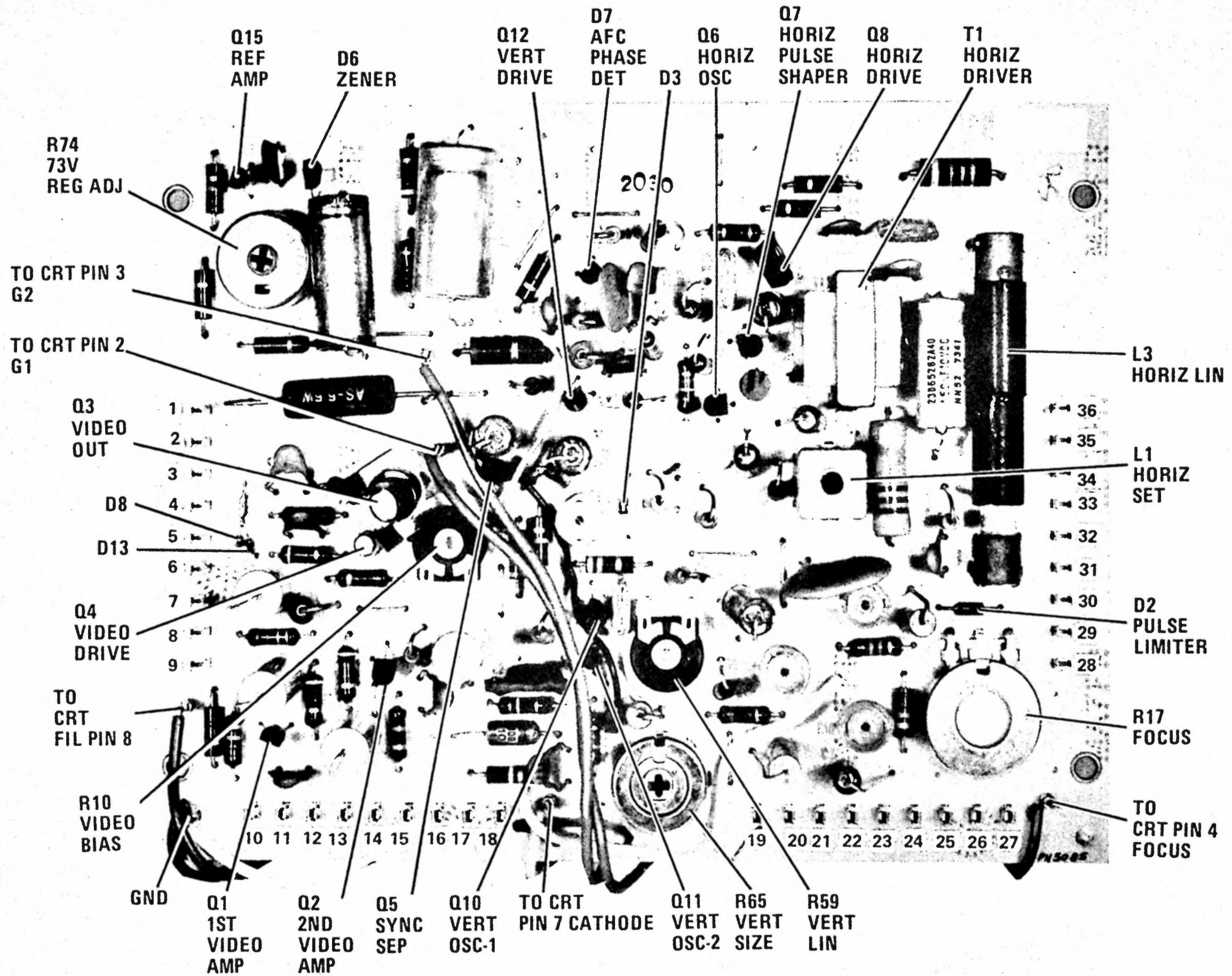

Monitor Panel - Component Side

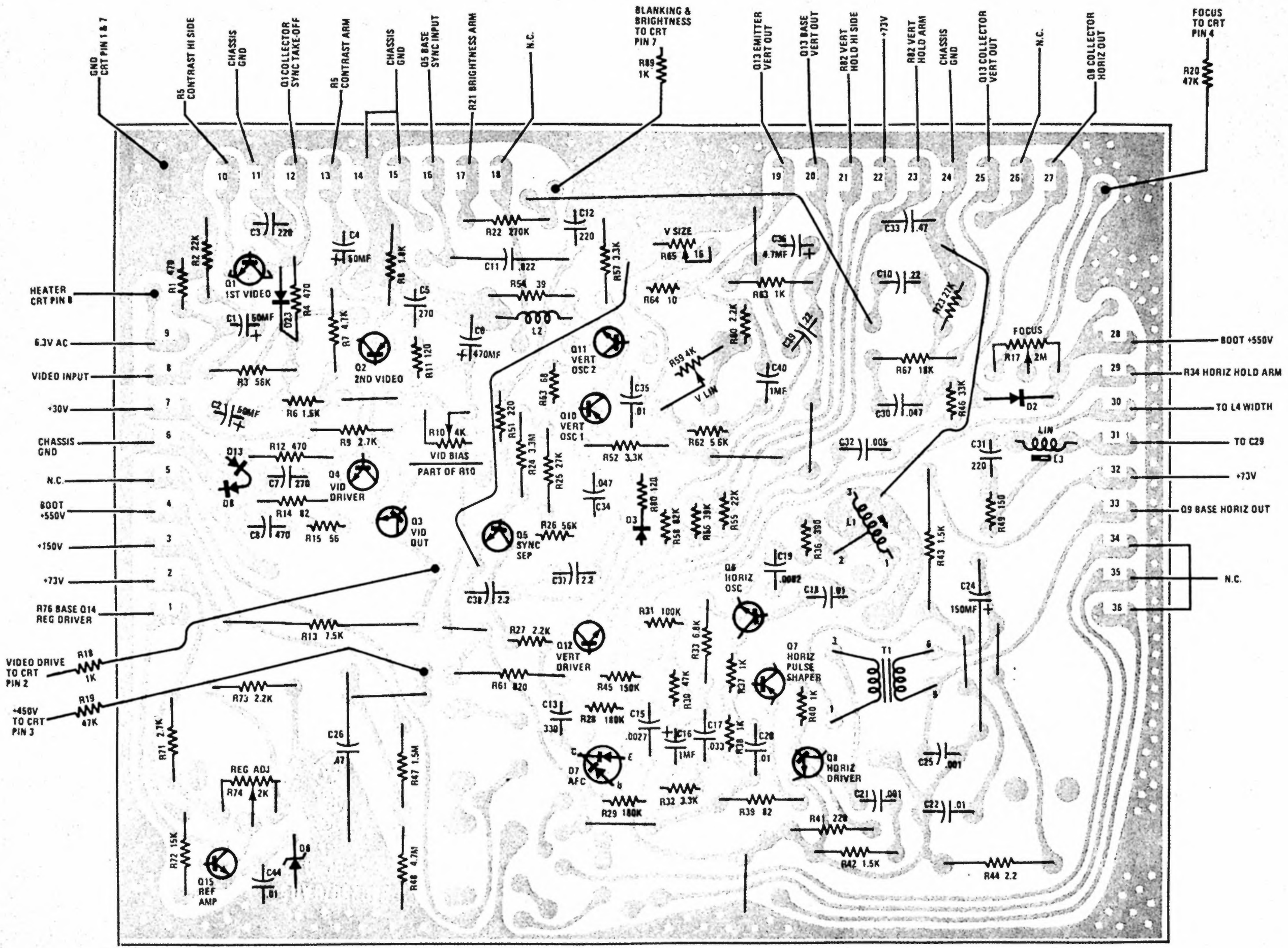

Monitor Panel - Circuit Side

PA-0006

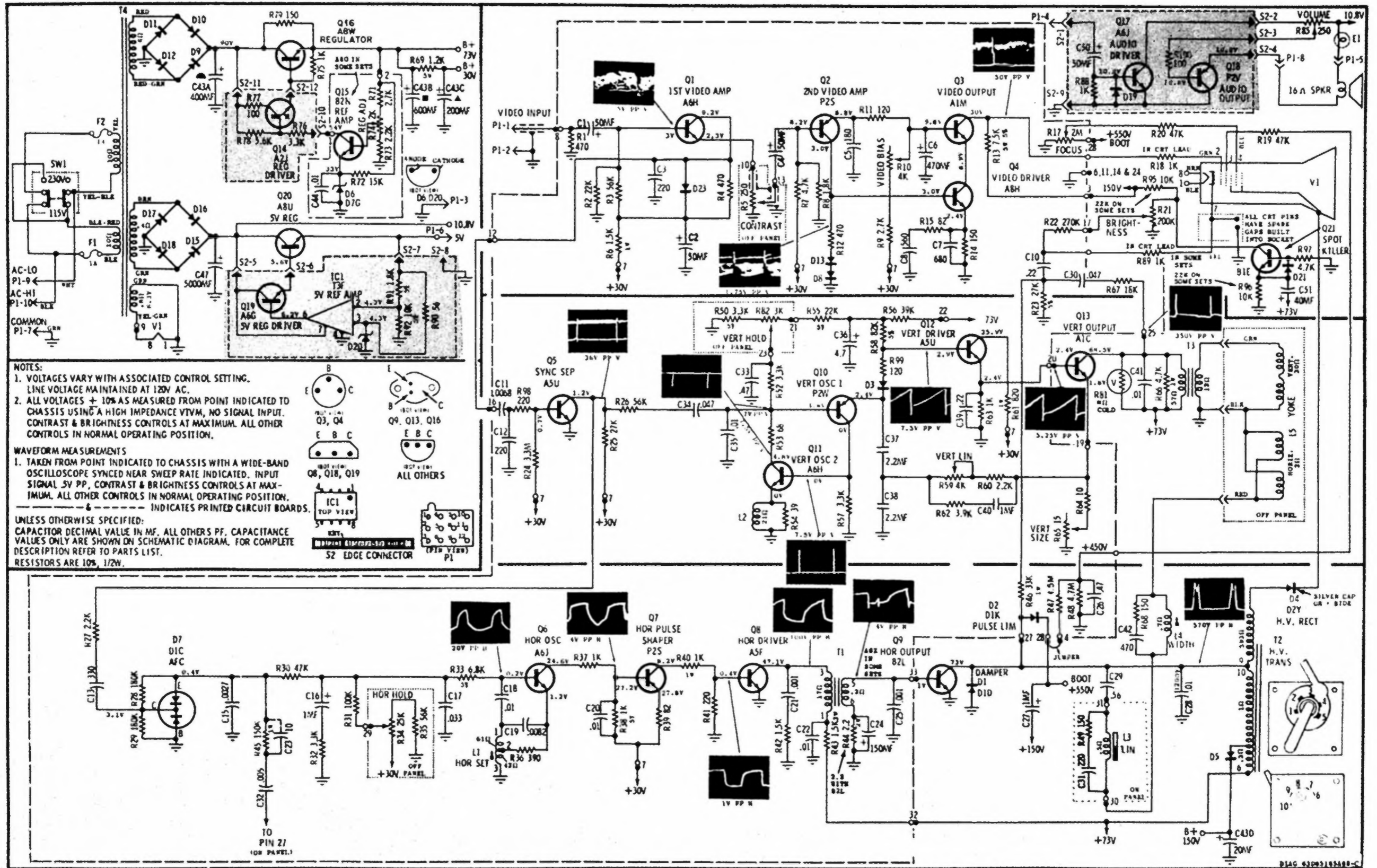

NOTES:
 1. VOLTAGES VARY WITH ASSOCIATED CONTROL SETTING. LINE VOLTAGE MAINTAINED AT 120V AC.
 2. ALL VOLTAGES + 10% AS MEASURED FROM POINT INDICATED TO CHASSIS USING A HIGH IMPEDANCE VTVM, NO SIGNAL INPUT. CONTRAST & BRIGHTNESS CONTROLS AT MAXIMUM. ALL OTHER CONTROLS IN NORMAL OPERATING POSITION.

WAVEFORM MEASUREMENTS
 1. TAKEN FROM POINT INDICATED TO CHASSIS WITH A WIDE-BAND OSCILLOSCOPE SYNCED NEAR SWEEP RATE INDICATED. INPUT SIGNAL .5V PP, CONTRAST & BRIGHTNESS CONTROLS AT MAXIMUM. ALL OTHER CONTROLS IN NORMAL OPERATING POSITION.

UNLESS OTHERWISE SPECIFIED:
 CAPACITOR DECIMAL VALUE IN MF. ALL OTHERS PF. CAPACITANCE VALUES ONLY ARE SHOWN ON SCHEMATIC DIAGRAM. FOR COMPLETE DESCRIPTION REFER TO PARTS LIST.
 RESISTORS ARE 10%, 1/2W.

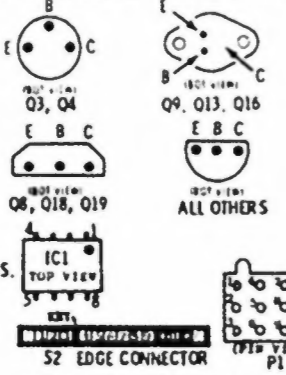

Schematic Diagram

REPLACEMENT PARTS LIST

REF. NO.	PART NUMBER	DESCRIPTION	REF. NO.	PART NUMBER	DESCRIPTION
ELECTRICAL PARTS			COILS & CHOKES		
	1Y25017A01	MONITOR PANEL: complete; KT364LM	L-1	24D68822A08	HORIZ SET
	1Y25017A02	POWER, Audio Panel: complete; KT365LM	L-2	24D68801A67	COMPENSATING: 2000 uh
CAPACITORS			L-3	24D69163A18	HORIZ LINEARITY
C-1	23C65282A41	50 mf 50V Lytic	L-4	24V25000A74	HORIZ WIDTH: incl C42 & R68
C-2	23C65282A41	50 mf 50V Lytic	L-5	24D68523A15	DEFLECTION YOKE
C-3	21S180D10	220 pf 20% 100V X5F (Use 21R132503)	TRANSISTORS		
C-4	23C65282A41	50 mf 50V Lytic	Q-1	48S137171	1st VIDEO: A6H
C-5	21S180B98	180 pf 10% 500V X5F	Q-2	48S137127	2nd VIDEO: P2S
C-6	23S10255A78	470 mf 16V Lytic	Q-3	48S134919	VIDEO OUTPUT: A1M
C-7	21S180C01	680 pf 10% 500V X5F	Q-4	48S137317	VIDEO DRIVER: A8H
C-8	21S180B85	560 pf 10% 500V X5F	Q-5	48S137115	SYNC SEPERATOR: A5U
C-10	8S10191B67	.22 mf 10% 250V Polyester	Q-6	48S137172	HORIZ OSCILLATOR: A6J
C-11	8S10191A54	.0068 mf 10% 160V Polyester	Q-7	48S137127	HORIZ PULSE SHAPER: P2S
C-12	21S180D10	220 pf 20% 100V X5F (Use 21R132503)	Q-8	48S137093	HORIZ DRIVER: A5F
C-13	21S131625	330 pf 10% X5F	Q-9	48S137570	HORIZ OUTPUT: B2L
C-15	21S180C41	.0027 mf 10% 500V Z5F (Use 21K121699)	Q-10	48S137173	VERT OSCILLATOR (1): P2W
C-16	23S10229A07	1.0 mf +40-20% 15V Lytic (Use 23C43280A17)	Q-11	48S137171	VERT OSCILLATOR (2): A6H
C-17	8S10191B90	.033 mf 10% 160V Polyester	Q-12	48S137115	VERT DRIVER: A5U
C-18	8S10299A73	.01 mf 10% 100V Poly carb	Q-13	48S134900	VERT OUTPUT: A1C
C-19	8S10299A74	.0082 mf 10% 160V Poly carb	Q-14	48S134952	REGULATOR DRIVER: A2J
C-20	8S10191B98	.01 mf 10% 250V Polyester	Q-15	48S137574	REFERENCE AMP: B2N
C-21	21S180B51	.001 mf 10% 500V X5F	Q-16	48S137368	REGULATOR: A8W
C-22	8S10191B98	.01 mf 10% 160V Polyester	Q-17	48S137172	AUDIO DRIVER: A6J
C-23	21S180C02	10 pf 10% N150	Q-18	48S137168	AUDIO OUTPUT: P2V
C-24	23D65282A40	150 mf 10V Lytic	Q-19	48S137169	5V REGULATOR, Driver: A6G
C-25	21S180B51	.001 mf 10% 500V X5F	Q-20	48S137344	5V REGULATOR: A8U
C-26	8S10212B53	.47 mf 10% 630V Mtlz Poly	Q-21	48S137476	SPOT KILLER: B1E
C-27	8S10212A11	1.0 mf 10% 630V Mtlz Poly	CONTROLS		
C-28	8S10571A06	.01 mf 5% 1200V Poly Prop Foil	R-5	18D68222A34	CONTRAST: 250 Ohm
C-29	8S10571A23	.56 mf 10% 250V Prop Foil	R-10	18D66401A44	VIDEO BIAS: 4K
C-30	8S10191A32	.047 mf 10% 250V Polyester	R-17	18D67858A12	FOCUS: 2 meg
C-31	21S180B87	220 pf 10% 500V X5F	R-21	18D68222A35	BRIGHTNESS: 200K
C32	21S180D34	.005 mf 20% 1KV Z5F (Use 21S180D31)	R-34	18D68222A37	HORIZ HOLD: 25K
C-33	8S10212A69	.47 mf 10% 100V Mtlz Poly	R-59	18D66401A44	VERT LINEARITY: 4K
C-34	8S10191A32	.047 10% 250V Polyester	R-65	18D67671A18	VERT SIZE: 15 Ohm
C-35	8S10191B98	.01 mf 10% 250V Polyester	R-74	17D65820A37	REGULATOR ADJUST: 2K
C-36	23S10255A69	4.7 mf 100V Lytic	R-82	18D68222A36	VERT HOLD: 3K
C-37	8S10212A20	2.2 mf 10% 100V Mtlz Poly	R-85	18D68222A34	VOLUME: 250 Ohm
C-38	8S10212A20	2.2 mf 10% 100V Mtlz Poly	RESISTORS		
C-39	8S10191B67	.22 mf 10% 250V Polyester	R-1	6S127633	470 10% 1/2W
C-40	8S10212A10	1.0 mf 10% 100V Mtlz Poly (Use 8S10191A46)	R-2	6S125568	22K 10% 1/2W
C-41	8S10064A06	.01 mf 10% 600V Mylar	R-3	6S127541	56K 10% 1/2W
C-42	21S180A71	470 pf 10% 500V X5F	R-4	6S127633	470 10% 1/2W
C43	23C65807A47	400 mf/125V; 600 mf/50V; 20 mf/200V Lytic	R-6	6S128955	1500 10% 1W
C-44	21S180E60	.01 mf +80-20% 50V Z5V	R-7	6S121847	4700 10% 1/2W
C-47	*23C65807A52	5000 mf 20V Lytic	R-8	6S122445	1800 10% 1/2W
C-50	23D65282A41	50 mf 50V Lytic	R-9	6S119926	2700 10% 1/2W
C-51	23S10255B43	40 mf 100V Lytic	R-11	6S128226	120 10% 1/2W
DIODES & RECTIFIERS			R-12	6S127633	470 10% 1/2W
D-1	48S134921	DIODE, Silicon: D1D; Damper	R-13	17S10731A02	7500 5% 5W WW
D-2	48S134978	DIODE, Silicon: D1K; Pulse Limiter	R-14	6S124797	150 10% 1/2W
D-3	48D67120A11	DIODE, Low Power	R-15	6S127516	82 10% 1/2W
D-4	48S137114	RECTIFIER, H. V.: Silicon: D2Y	R-18	---	Part of CRT socket assembly
D-5	48S191A05	RECTIFIER, Silicon: 91A05 (Use 48S191A07)	R-19	---	Part of CRT socket assembly
D-6	48S137469	DIODE, Silicon: zener: D7G	R-20	---	Part of CRT socket assembly
D-7	48S134917	DIODE, Dual: D1C; Detector	R-22	6S129296	270K 10% 1/2W
D-8	48S67120A11	DIODE, Low Power	R-23	6S10053C67	27K 5% 1/2W
D-9	*48S191A07	RECTIFIER, Silicon: 91A07	R-24	6S127538	3.3 meg 10% 1/2W
D-10	48S191A07	RECTIFIER, Silicon: 91A07	R-25	6S121300	27K 10% 1/2W
D-11	48S191A07	RECTIFIER, Silicon: 91A07	R-26	6S127541	56K 10% 1/2W
D-12	48S191A07	RECTIFIER, Silicon: 91A07	R-27	6S129875	2200 10% 1/2W
D-13	48D67120A11	DIODE, Low Power	R-28	6S125531	180K 10% 1/2W
D-15	48S191A10	RECTIFIER, Silicon: 91A10	R-29	6S125531	180K 10% 1/2W
D-16	48S191A10	RECTIFIER, Silicon: 91A10	R-30	6S125892	47K 10% 1/2W
D-17	48S191A10	RECTIFIER, Silicon: 91A10	R-31	6S125534	100K 10% 1/2W
D-18	48S191A10	RECTIFIER, Silicon: 91A10	R-32	6S124506	3300 10% 1/2W
D-19	48D67120A11	DIODE, Low Power	R-33	6S10053C53	6800 5% 1/2W
D-20	*48S10641D43	DIODE, Silicon, D4,3	R-35	6S127541	56K 10% 1/2W
D-21	48D67120A11	DIODE, Low Power	R-36	6S125545	390 10% 1/2W
D-23	48S191A05	RECTIFIER, Silicon: (Use 48S191A07)	R-37	6S121301	1000 10% 1/2W
FUSES			R-38	6S10053C33	1000 5% 1/2W
F-1	65S139424	FUSE: 1A-250V	R-39	6S127516	82 10% 1/2W
F-2	65S139424	FUSE: 1A-250V	R-40	6S127547	1000 10% 1W
INTEGRATED CIRCUITS			R-41	6S127099	220 10% 1/2W
IC-1	*51S10732A01	INTEGRATED CIRCUIT: T3F	R-42	6S127513	1500 10% 1/2W
			R-43	17S10130B07	1500 10% 3W fxd mtl film
			R-44	17S744356	2.2 10% 2W WW
			R-45	6S120141	150K 10% 1W
			R-46	6S127634	33K 10% 1W
			R-47	6S129417	1.5 MEG 10% 1/2W
			R-48	6S10053D21	4.7 meg 10% 1/2W
			R-49	6S124797	150 10% 1/2W
			R-50	6S10053C45	3300 5% 1/2W
			R-52	6S124506	3300 10% 1/2W
			R-53	6S129874	68 10% 1/2W
			R-54	6S131972	39 10% 1/2W
			R-55	6S10053C65	22K 5% 1/2W
			R-56	6S125535	39K 10% 1/2W
			R-57	6S124506	3300 10% 1/2W
			R-58	6S129793	82K 5% 1/2W
			R-60	6S129875	2200 10% 1/2W
			R-61	6S10053F29	820 10% 1W
			R-62	6S127515	3900 10% 1/2W

REPLACEMENT PARTS LIST

REF. NO.	PART NUMBER	DESCRIPTION	REF. NO.	PART NUMBER	DESCRIPTION
R-63	6S121301	1000 10% 1/2W			
R-64	17S10130C91	10 10% 1/2W (special)			
R-66	6S129064	4700 10% 1W			
R-67	6S122848	18K 10% 1/2W			
R-68	6S124797	150 10% 1/2W			
R-69	17S647132	1200 10% 5W WW (Use 17S136197)			
R-71	6S119926	2700 10% 1/2W			
R-72	6S124551	15K 10% 1/2W			
R-73	6S129875	2200 10% 1/2W			
R-75	6S121301	1000 10% 1/2W			
R-76	6S124506	3300 10% 1/2W			
R-77	6S129221	100 10% 1/2W			
R-78	6S127005	5600 10% 1/2W			
R-79	17S135589	150 10% 10W WW			
R-81	6C66263A08	VARISTOR (Use 6S66263A16)			
R-88	6S121301	1000 10% 1/2W			
R-89	---	Part of CRT Socket			
R-90	6S131412	56 10% 1/2W			
R-91	6S10053C39	1800 5% 1/2W			
R-92	6S10053C57	10K 5% 1/2W			
R-95	6S119932	10K 10% 1/2W			
R-96	6S119932	10K 10% 1/2W			
R-97	6S121847	4700 10% 1/2W			
R-98	6S127099	220 10% 1/2W			
R-99	6S128226	120 10% 1/2W			
R-100	6S129221	100 10% 1/4W			
SWITCHES					
SW-1	40S10624A01	SWITCH, Slide: DPDT (115V-230V)			
TRANSFORMERS					
T-1	25D67440A03	HORIZ DRIVER			
T-2	24D25240A04	H.V. TRANSFORMER: complete			
T-3	25D25221A07	VERT OUTPUT			
T-4	*25D68164A31	POWER			
MISCELLANEOUS ELECTRICAL PARTS					
V-1	20WP4	CRT (XM501-10 19VP111)			
	23JEP4	CRT (XM701-10 23VP111)			
			E-1	50D68164A27 65S139451	SPEAKER: 4" PM LAMP: No. 1436
			MECHANICAL PARTS		
				9D66133A28	CAP, SS Rect (HV Transformer - PRI/SEC lead)
				42B25158A01 31D70080B04	CLAMP, Metal : Defl Yoke Mtg CONNECTOR, PC panel: 9 contact; on chassis
			S-2	*15S10390A06	CONNECTOR, PC panel: 12 contact; less key and contacts (power-audio panel)
			P-1	*15S10183A69	CONNECTOR, Plug: 12 contact; less contacts (power)
				*39S10184A63	CONTACT, Plug: for power connector 15S10183A69
				39S10184A22	CONTACT: for S2 connector
				15S10630A01	COVER, nylon: slide switch; SW1
				*7S10609A03	GROMMET, Plastic: PC panel mtg
				26C66745A05	HEAT SINK: Q3
				*26C25198A01	HEAT SINK: Q20
				9C66238A02	HOLDER, Fuse: F1 & F2
				14A562353	INSULATOR, Mica: Transistor socket; Q9, Q13, Q16 & Q20 (Use 14A543810)
				28S10733A01	KEY, Plug: for S2 connector
				2S7051	NUT, hex: 3/8-32; control mtg
				5S10281A03	RIVET, drive pin: nylon; HV transf mtg
				47C66082A03	ROD, Adjustment: width coil; L4
				3S136050	SCREW, tpg: 6-20 x 1/2 clu pan hd; Q9, Q13, Q16 & Q20
				9S10143A41	SOCKET, lamp: E1
				9D67555V27	SOCKET, CRT: incl leads & resistors
				*9D25201A01	SOCKET, HV Rectifier (4): complete; incl 2nd anode lead & cup
				9C63825A01	SOCKET, transistor: Q9, Q13, Q16
				9C63825A02	SOCKET, transistor: Q20
				41D65987A01	SPRING, special: CRT aquadag grnd
				66P65173A47	TOOL, contact removal (S2 connector)

* DENOTES NEW ITEM APPEARING ON ANY LIST FOR FIRST TIME.