



**PRELIMINARY
OWNER'S MANUAL**

SEGA[®]

**MANUAL PART NO.
420-0979**

GAME CONCEPT

Jungle drums pound as CONGO BONGO™, the cartoon adventure that pits man against monkey, takes you on the craziest, most action-packed safari ever! With fantastic 3-dimensional-like graphics and wonderful native sounds, SEGA's CONGO BONGO lures explorers of all ages to chase Bongo, the mischievous gorilla, through four vivid scenes of jungle fun. By use of an 8-way joystick and a jump button, the player maneuvers his hunter through the various scenes and avoids obstacles and dangers in his path.

In the first scene, Bongo roars defiantly from the top of Steep Peak as the hunter approaches. The hunter must climb the treacherous cliffside to reach the bridge above, while avoiding the bouncing coconuts Bongo throws down. Once across the bridge, the hunter must slide down a slope and knock the green monkey off the ledge. Green monkeys will block the hunter's path and if not pushed over a cliff or jumped over, the hunter cannot pass.

Next the hunter must jump over a perilous, collapsing chasm and climb the cliff to Primate Plateau. Here several friendly-looking monkeys scamper about playfully. Be careful though, as the cheerful chimps will cling to the hunter, slowing him down. By using the jump button, the player can shake the chimps off the hunter, but it must be done quickly, because if three chimps grab the hunter, they will pick the hunter up and throw him over the side and into the river. Once past the monkeys, the hunter must jump the river again and climb up to the top where a chagrined Bongo loses his smile and runs off into the jungle.

In the second scene, Bongo taunts the hunter from across Snake Lake. Immediately scorpions descend upon the hunter and he must decide which route to take quickly. Snake Lake is a maze of bridges and islands with snakes guarding every route. The hunter must avoid the snakes by jumping over them. The hunter should attempt to reach the island nearest Bongo and jump onto the back of the hippo and then safely to shore. Beware of the hippo as he dives and surfaces. Once safely to shore, Bongo gets worried and scampers off again.

The third scene opens with the hunter in a mole hole on Rhino Ridge. A herd of charging rhinos must be avoided in the hunter's attempt to capture Bongo. The hunter can avoid the rhinos by jumping over them or ducking into a mole hole. When ducking into a mole hole, the player must depress the jump button for the hunter to tuck down and avoid the rhinos.

In the fourth scene, a weary Bongo naps in a chair on the far side of Lazy Lagoon. To reach Bongo, the hunter must cross Lazy Lagoon by jumping on lily pads, hippos and fish, that might sink at minute. Once across Lazy Lagoon, the hunter must dodge the last charging rhinos and climb the last bluff to capture Bongo. After Bongo is captured, the scenes repeat with increasing difficulty.

CONGO BONGO is a one or two player game with players alternating at the loss of each hunter. Each scene is timed by the bonus counter in the upper left corner of the screen. As time passes, the bonus decreases. If the bonus counter reaches zero, the player loses that hunter, the bonus counter is reset and play continues if he has other hunters available. Game ends with the loss of the last hunter.

SCORING

	<u>POINTS</u>
EACH STEP TAKEN	10
JUMPING ONTO HIPPO, FISH OR LILY PAD (INCREASES BY 50 EACH ROUND)	100
JUMPING INTO A MOLE HOLE	1000
JUMPING ACROSS A CHASM	500

AT THE SUCCESSFUL COMPLETION OF EACH ROUND, THE PLAYER IS AWARDED THE NUMBER OF POINTS REMAINING IN THE BONUS BOX.

OPTION SELECTION

○ OPTION SWITCH SETTINGS

DIP SW NO.1

OPTION		1	2	3	4	5	6	7	8
UPRIGHT									OFF
TABLE									ON
SOUND ON								ON	
SOUND OFF								OFF	
FREE PLAYS						OFF	OFF		
5 MEN						OFF	ON		
4 MEN						ON	OFF		
3 MEN						ON	ON		
GAME DIFFICULTY	EASY			ON	ON				
	MEDIUM			ON	OFF				
	HARD			OFF	ON				
	HARDEST			OFF	OFF				
EXTRA SCORE	10,000	ON	ON						
	20,000	ON	OFF						
	30,000	OFF	ON						
	40,000	OFF	OFF						

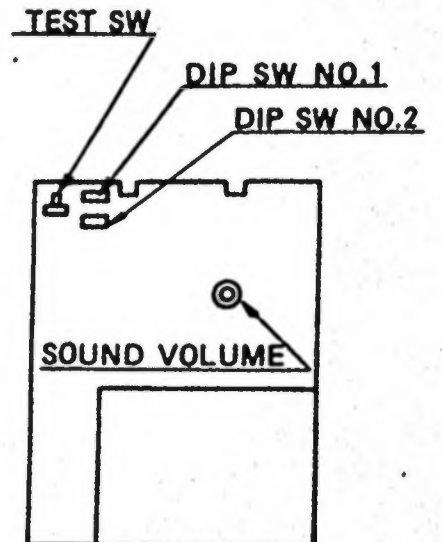

○ COIN / CREDIT OPTIONS SWITCH

DIP SW NO.2

OPTION		1	2	3	4	5	6	7	8
4 COINS	1 CREDIT	ON	ON	ON	ON	ON	ON	ON	ON
3 COINS	1 CREDIT	ON	ON	ON	OFF	ON	ON	ON	OFF
2 COINS	1 CREDIT	ON	ON	OFF	ON	ON	ON	OFF	ON
1 COIN	1 CREDIT	ON	ON	OFF	OFF	ON	ON	OFF	OFF
1 COIN	2 CREDITS	ON	OFF	ON	ON	ON	OFF	ON	ON
1 COIN	3 CREDITS	ON	OFF	ON	OFF	ON	OFF	ON	OFF
1 COIN	4 CREDITS	ON	OFF	OFF	ON	ON	OFF	OFF	ON
1 COIN	5 CREDITS	ON	OFF	OFF	OFF	ON	OFF	OFF	OFF
1 COIN	6 CREDITS	OFF	ON	ON	ON	OFF	ON	ON	ON
2 COINS	1 CREDIT								
4 COINS	2 CREDITS	OFF	ON	ON	OFF	OFF	ON	ON	OFF
5 COINS	3 CREDITS								
6 COINS	4 CREDITS								
2 COINS	1 CREDIT								
3 COINS	2 CREDITS	OFF	ON	OFF	ON	OFF	ON	OFF	ON
4 COINS	3 CREDITS								
1 COIN	1 CREDIT								
2 COINS	2 CREDITS								
3 COINS	3 CREDITS	OFF	ON	OFF	OFF	OFF	ON	OFF	OFF
4 COINS	4 CREDITS								
5 COINS	6 CREDITS								
1 COIN	1 CREDIT								
2 COINS	2 CREDITS	OFF	OFF	ON	ON	OFF	OFF	ON	ON
3 COINS	3 CREDITS								
4 COINS	5 CREDITS								
1 COIN	1 CREDIT								
2 COINS	3 CREDITS	OFF	OFF	ON	OFF	OFF	OFF	ON	OFF
1 COIN	2 CREDITS								
2 COINS	4 CREDITS								
3 COINS	6 CREDITS	OFF	OFF	OFF	ON	OFF	OFF	OFF	ON
4 COINS	8 CREDITS								
5 COINS	11 CREDITS								
1 COIN	2 CREDITS								
2 COINS	4 CREDITS								
3 COINS	6 CREDITS	OFF	OFF	OFF	OFF	OFF	OFF	OFF	OFF
4 COINS	9 CREDITS								
		COIN SW1(A)				COIN SW2(B)			

SELF-TEST

CONGO BONGO™ is equipped with a diagnostics self-testing program that is initiated by pressing the Self-Test button located on the Volume Control Block Assembly. The test is used to detect malfunctions in Video alignment, I/O interface and P.C.B. electronics.

The test will appear in the following order, with the words "OK" or "BAD" being displayed on the screen in accordance with the condition of the tested circuit. Self-Test step sequencing is done by pressing the Player 1 button after each individual test.

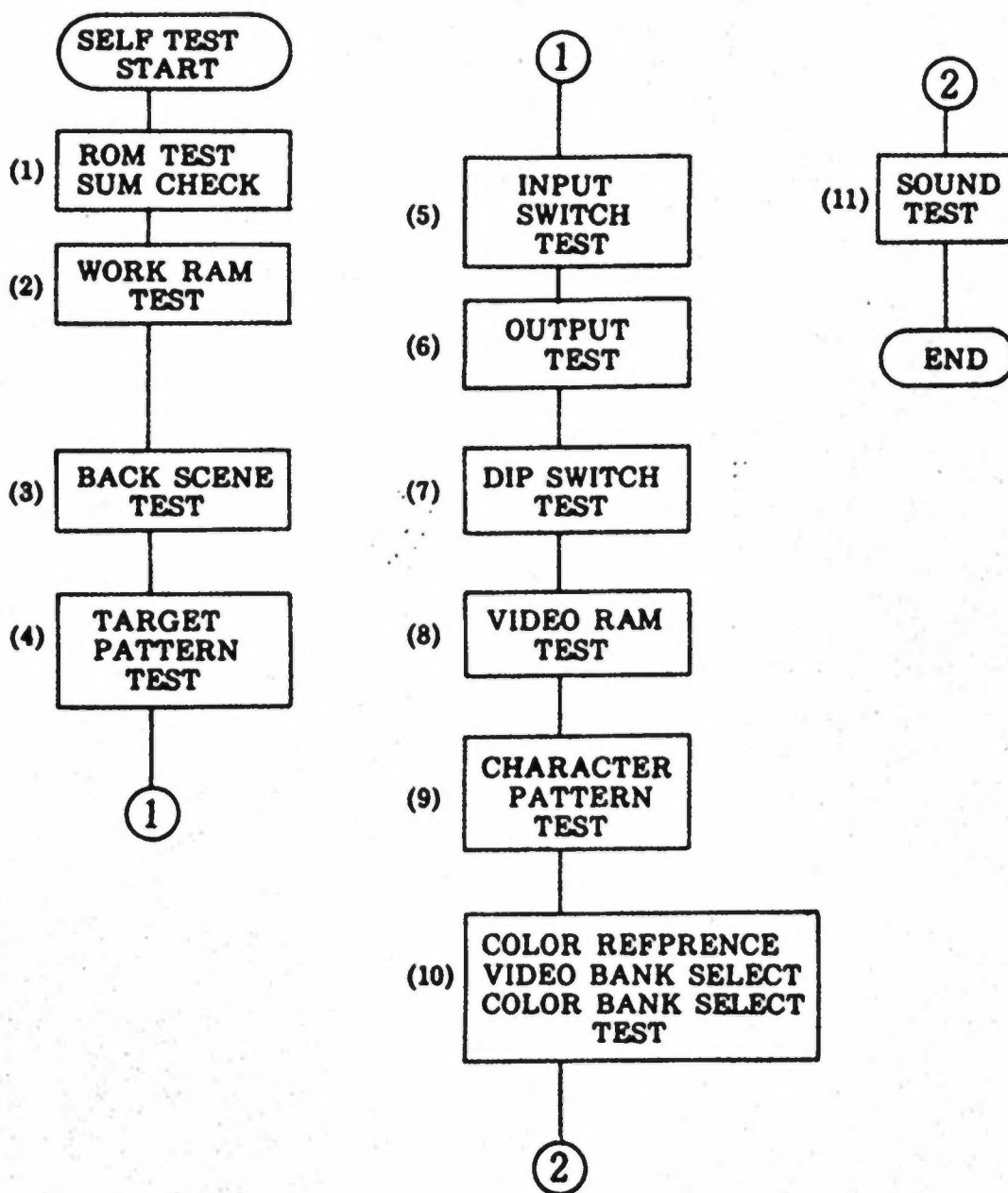

SELF-TEST (cont.)

1. ROM Test

This test checks the four main program EPROMs by performing individual "check sum" tests. These EPROMs are located on the Control Board.

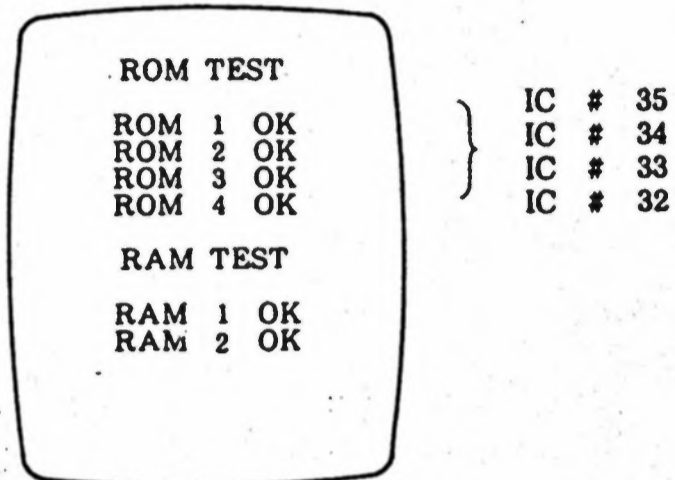

2. RAM Test

This test checks RAM 1 and RAM 2 by performing a cross-talk test between each adjacent bit in the RAMs. These RAMs are located on the Control Board.

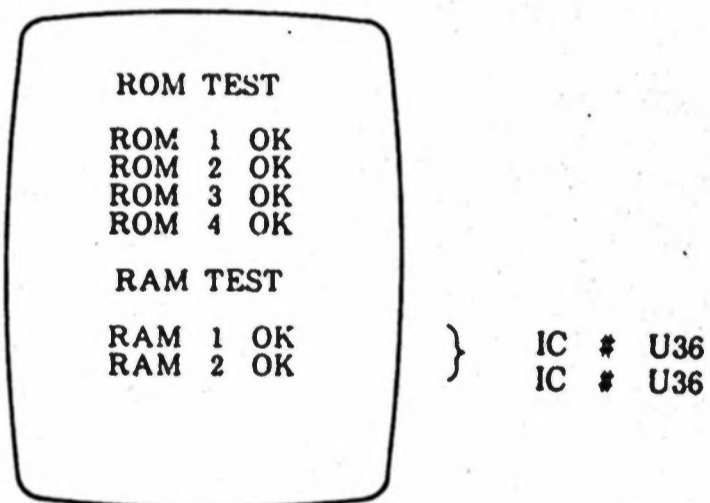

3. Background Scene Test

This test checks the background displays of the game in eight (8) individual steps. Advance through the steps by pressing the Player 1 button, until the eighth display (a blank screen) is reached.

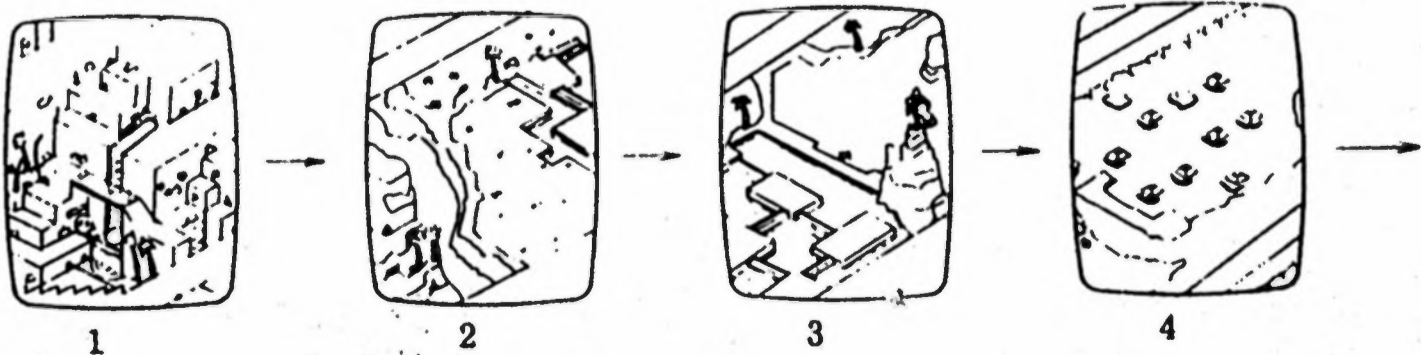

SELF-TEST (cont.)

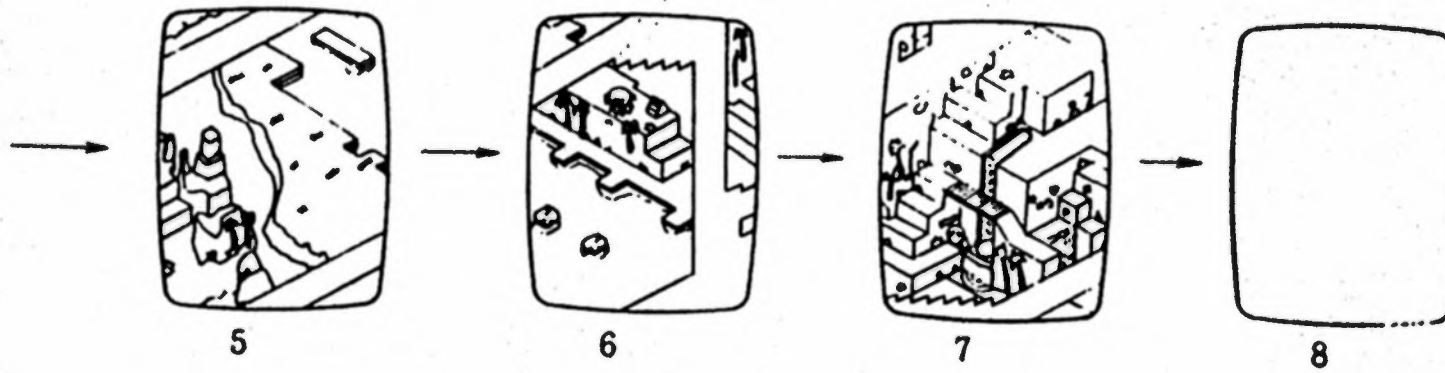

4. Target Test

Here we check the target patterns used in the game in eight (8) individual steps. Again, advance through the test with the Player 1 button, scene by scene. Movement and 180° Flip (for Cocktail Tables) are verified here as well.

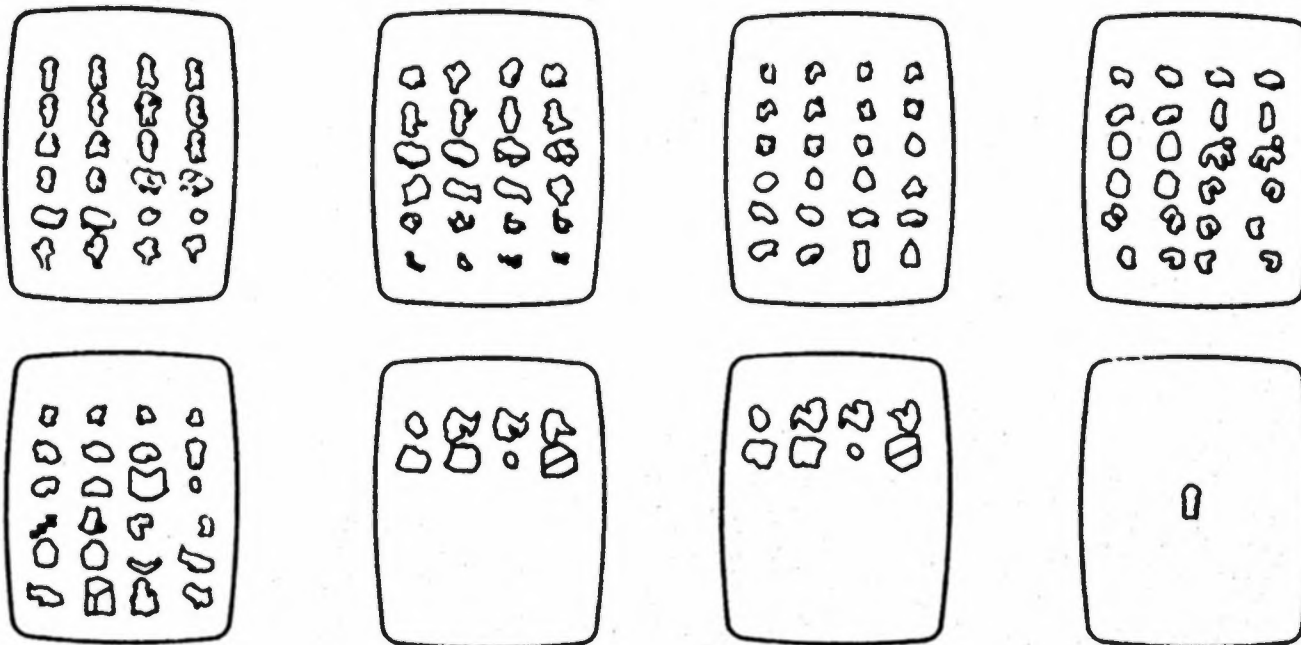

5. Input Test

This test checks the input switches used for operator control, and input signals from the player controls to software.

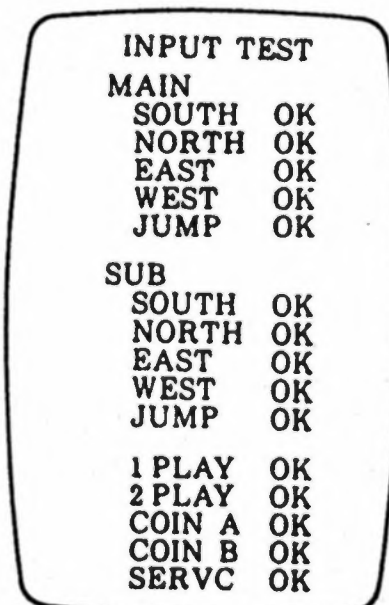

SELF-TEST (cont.)

6. Output Test

This test verifies output ports used to interface computer software to game hardware.



7. DIP Switches

Operation of the DIP Switches are checked here, internally, by simultaneously turning on, and then off, all odd switch positions, followed by all even switch positions. "Test 1" is displayed at the end of the cycle. Pressing the Player 1 button initiates "Test 2" for DIP Switch 2.

8. Video RAM Test

Here Video RAMs used for character pattern display are tested. These RAMs are located on the Video Board.

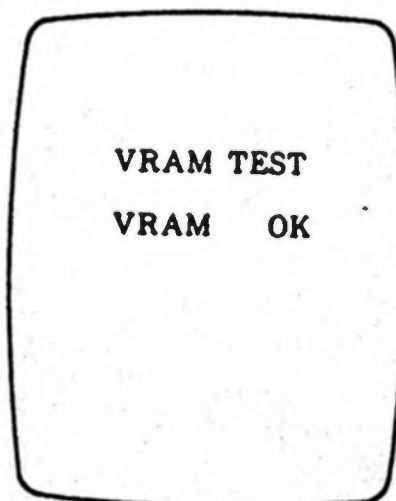

SELF-TEST (cont.)

9. Character Pattern Test

This test checks the ROMs used for character patterns and picture patterns. During this test all the patterns contained within each ROM will be displayed. Character pattern ROMs are located on the Video Board.

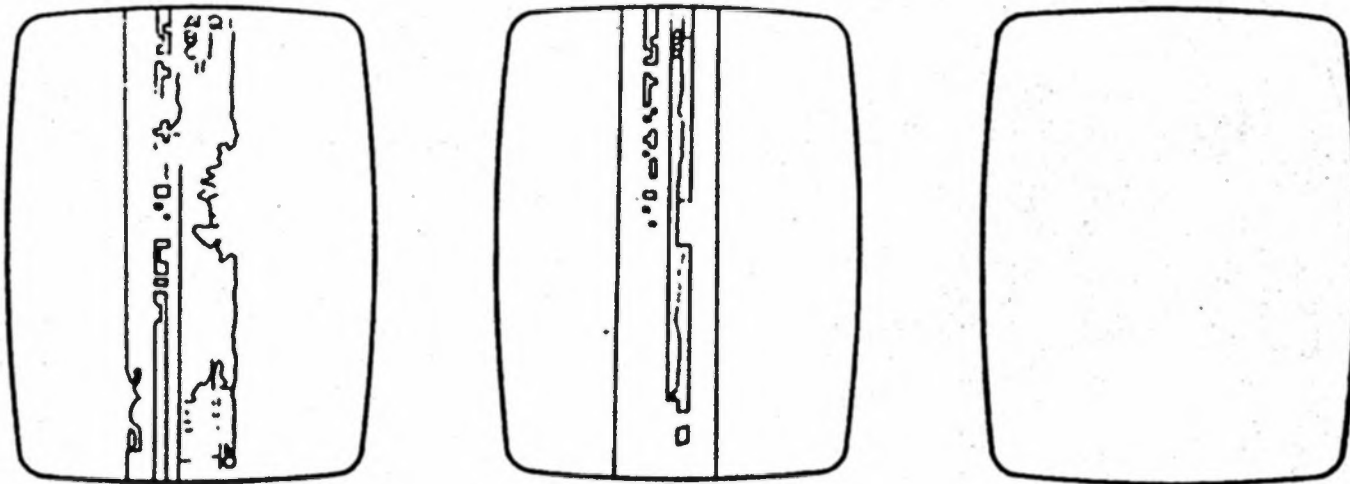

10. Color Control Reference Test

Character pattern and background picture color control is checked here by color reference changes with each pressing of the Player 1 button.

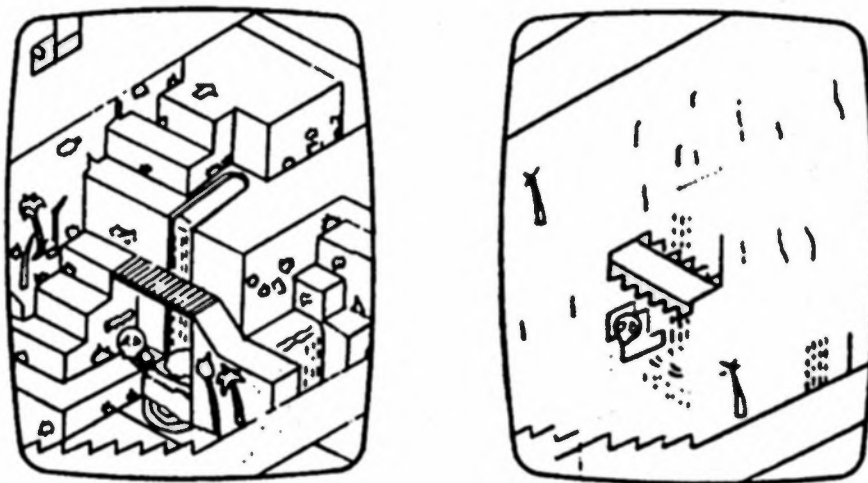

11. Sound Port Test

This test verifies that proper sound outputs are generated with each pressing of the Player 1 button. Twenty-nine individual sounds are generated, one at a time, sequenced by the Player 1 button, and appear in order on the following page.

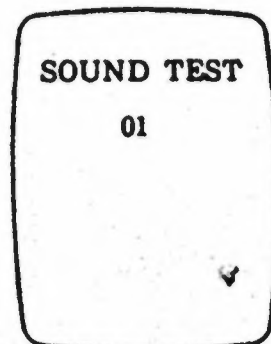

SELF-TEST (cont.)

11. Sound Port Test (cont.)

- 01 No sound
- 02 Gorilla lullaby
- 03 Player victory music
- 04 Player clear music
- 05 "Player goes to Heaven" music (in the water)
- 06 "Player goes to Heaven" music (other than in the water)
- 07 Fire
- 08 Player step sound
- 09 Player drop sound
- 10 Player jump sound
- 11 "Monkey on my back" sound
- 12 Held by monkey sound
- 13 Hit by coconuts sound
- 14 "Crumbling crevasse" sound
- 15 Passage of snake sound
- 16 Rush of rhino sound (A)
- 17 Rush of rhino sound (B)
- 18 Rhino screeching to a stop sound
- 19 Player digging sound
- 20 Fish sound
- 21 Special Bonus sound
- 22 Credit sound
- 23 Gorilla laughing
- 24 Hippo sinking sound
- 25 Background music for scene # 1
- 26 Background music for scene # 2
- 27 Background music for scene # 3
- 28 Background music for scene # 4
- 29 Bonus score up sound