



# **Continental Circuit™**

## **OPERATING MANUAL**



**TAITO AMERICA CORPORATION**  
660 S. Wheeling Road, Wheeling, IL 60090  
Telephone (312) 520-9280 Telex 253290

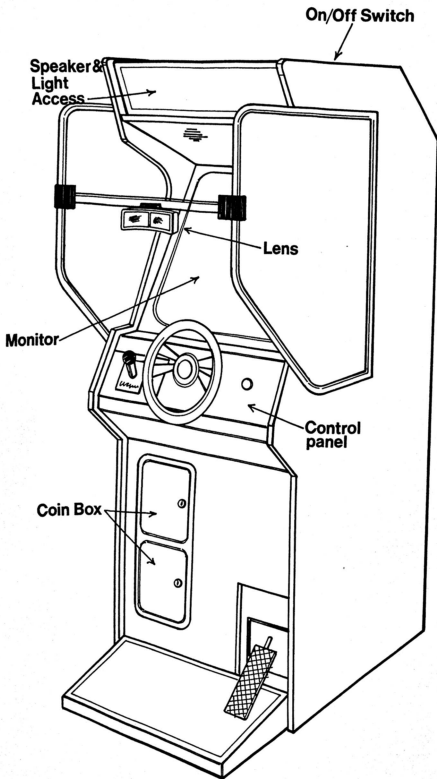

TABLE OF CONTENTS

	Page Numbers
INSTALLATION .....	1 - 2
GAME OPERATION & PLAY INSTRUCTIONS .....	2 - 4
TEST SWITCHES & GAME ADJUSTMENTS .....	5 - 7

**\* WARNING \***

THIS GAME MUST BE PROPERLY GROUNDED. FAILURE TO DO SO  
MAY RESULT IN DESTRUCTION TO THE ELECTRONIC COMPONENTS.



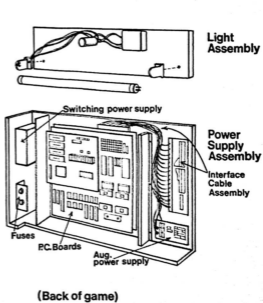
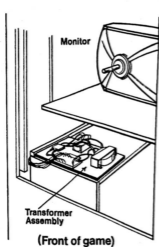
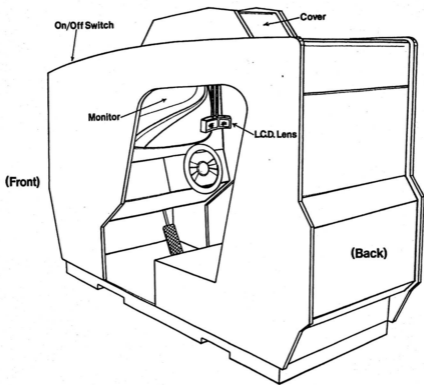

## I. GAME INSPECTION

Continental Circuit has been thoroughly tested and readied for operation at the factory and should not require any special set-up procedure. However it is suggested that upon receiving your game you examine the following to further insure the game is in proper working condition:

### CHECK:

- [ ] Plug-in connectors are firmly seated.
- [ ] All player control connections are complete.
- [ ] No loose components on p.c. board.
- [ ] Fuses are installed firmly in holders.
- [ ] Coin mechanisms are operating properly.
- [ ] No loose foreign objects in cabinet (screws, components, etc.) which may cause shorting and result in damage to the game.

If problems do occur or technical assistance is required, please call our customer service department at 312/520-9280.

## II. POWER REQUIREMENTS

The game is shipped ready for operation at 120VAC, 60Hz with a power consumption of approximately 250 watts.

---

### C A U T I O N

FOR SAFE OPERATION IT IS STRONGLY RECOMMENDED THE CABINET BE PROPERLY GROUNDED. THIS GAME IS EQUIPPED WITH A THREE CONDUCTOR POWER CABLE. THE THIRD PRONG (round in shape) WILL AUTOMATICALLY GROUND THE GAME WHEN PLUGGED INTO A PROPERLY GROUNDED THREE PRONG RECEPTICAL. IF IT BECOMES NECESSARY TO USE AN ADAPTOR, THE GROUNDING LUG OR WIRE ON THE ADAPTOR MUST BE PROPERLY GROUNDED TO ASSURE SAFE OPERATION.

---

## III. GAME INSTALLATION

The following precautions should be followed when installing the game:

- \* Handle the game with care so as not to damage the fragile picture tube.
- \* Do NOT install the game in direct sunlight or near a heat source. Doing so might cause the internal temperature of the game to exceed it's maximum operating temperature and could result in damage to

the game's components.

\* Do not install the game in excessively dusty or damp environments.

#### IV. PLAY INSTRUCTIONS

The game allows the player to compete in as many as 8 different races, each performed on a different course. The player must complete each course within the specified "Time" limit. A check point located on each course will help the player by increasing the "Time" remaining. In addition, each course has a minimum "Qualifying Rank". The player must complete each course within the "Qualifying Rank" and within the specified time limit to continue playing into the next course. If he fails to beat the Qualifying Rank and doesn't finish the race within the specified time limit, the game will end.

The "Time" given to reach the first check point and the "Qualifying Rank" for each course are listed below:

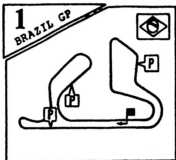

- o Time ..... 60 Seconds
- o Qualifying Rank .. 80th

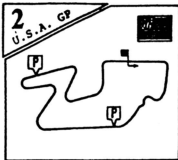

- o Time ..... 30 Seconds
- o Qualifying Rank .. 60th

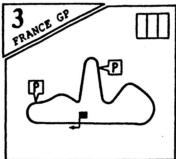

- o Time ..... 40 Seconds
- o Qualifying Rank .. 50th

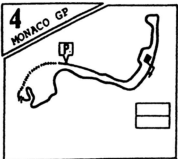

- o Time ..... 70 Seconds
- o Qualifying Rank .. 40th

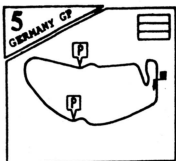

- o Time ..... 40 Seconds
- o Qualifying Rank .. 30th



- o Time ..... 70 Seconds
- o Qualifying Rank .. 20th

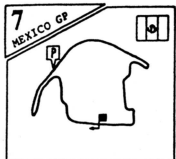

- o Time ..... 50 Seconds
- o Qualifying Rank .. 10th

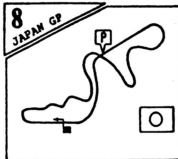

- o Time ..... 45 Seconds
- o Qualifying Rank .. 3rd

NOTE: The speed at which the "Timer" decrements and the speed of the opponents' cars can be increased by adjusting the difficulty level. There are four difficulty levels available for both of these options. (See page # 7)

#### V. HOW TO PLAY

- 1.) Insert Coin(s) (Standard pricing is 2 coins per 1 play.)
- 2.) Adjust the height and position of the scope to a level comfortable to look through.

- 3.) Press "Start" button.
- 4.) Using the steering wheel for direction and the accelerator and shift lever for speed, drive your car to the finish line within the specified "Time" limit and beat the "Qualifying Rank".
- 5.) When a flashing accident panel (fire extinguisher or tire) appears in the upper right corner of your viewing area, proceed to the nearest "Pit In" area for repair. The "Time" stops elapsing while the player is in the "Pit In" area. Do NOT overlook the "Pit In" area.
- 6.) The player's car will explode when it touches opponents' cars or other obstacles in the road twice.
- 7.) When the game reaches Game Over the player is given an opportunity to continue play. At this point the screen displays the following message:

```
CONTINUE                O K ?  
10 <----- Time (counting down)  
YES                      NO  
PUSH START BUTTON
```

The player turns the steering wheel left or right to select YES or NO. The selection must be made within 10 seconds. Once the selection is made the player presses the START button. Play will begin from the last circuit played in the previous game.

## VI. SELF-TEST MODE

To enter the Self-Test Mode, locate Dip Switch A on the p.c. board and slide switch #3 to the ON position.

- \* The first test screen displays a cross-hatch and color bars to be used when adjusting the color monitor.
- \* Press the Start button to display the following Self-Test Mode:

```

                TEST  MODE
COINA:OFF      COINS:OFF
SERVICE:OFF   TILT:OFF
STARTSW:OFF
HANDLE:00     ACCEL:0
SHIFT:LO     BRAKE:0
SOUNDCORDE:17
                87854321
DIPSW A:HHHHLHL  L:ON
DIPSW B:HHHHHHH  H:OFF
                SOUND OK
                RAM OK
                ROM OK

```

- \* When testing the switches for COINS, SERVICE, START and TILT, simply press the switch and the display for that switch should change from OFF to ON.
- \* When testing the SHIFT lever, the display of LO should change to HI when the lever is shifted into high.
- \* When testing the HANDLE (Steering Wheel), the display of 00 should change alphabetically when turning it right and numerically when turning it left.
- \* When testing the ACCELERATOR, the display of 0 is changed when the accelerator pedal is pressed.
- \* The large letters L and R, displayed on each side of the test screen, will indicate if there is a wiring problem in the left or right lenses of the scope.
- \* When using the SOUNDCORDE display to test game sounds, press down on the accelerator pedal to select a sound and press the start button to test the output of that sound.
- \* The display for DIPSW A and DIPSW B indicate the position of the dip switches. H = Off L = On.

- \* The SOUND, RAM, and ROM tests display OK if no abnormal conditions exist. If the test program senses an abnormal condition, the display will indicate an ERROR.
- \* To exit the Self-Test Mode, locate Dip Switch A on the p.c. board and return switch #3 to the OFF position.

#### VII. SERVICING

To service the Logic Board, Power Supply and Fuses - remove the rear door.

To service the Monitor, Foot Pedal and Steering Wheel - remove the front door.

NOTE: The steering panel may be removed for easier servicing.

DIP SWITCH SETTINGSTATO

The following option switch settings were designed to allow the customizing of CONTINENTAL CIRCUIT'S various game features to suit different environments. If used wisely, the flexibility they offer can maximize game performance and increase potential earnings.

DIP SWITCH A

SETTINGS	POSITION	1	2	3	4	5	6	7	8
GAME STYLE	COCKPIT UPRIGHT	OFF ON							
DISCOUNTED CONTIN. PLAY	DISABLED ENABLED		OFF ON						
TEST MODE	NORMAL GAME TEST MODE			OFF ON					
ATTRACT SOUNDS	ENABLED DISABLED				OFF ON				
PLAY PRICING COIN A	1 CO = 1 PL 1 CO = 2 PL 2 CO = 1 PL 2 CO = 3 PL					OFF ON OFF ON	OFF OFF ON ON		
PLAY PRICING COIN B	1 CO = 1 PL 1 CO = 2 PL 2 CO = 1 PL 2 CO = 3 PL							OFF ON OFF ON	OFF OFF ON ON

DIP SWITCH B

SETTINGS	POSITION	1	2	3	4	5	6	7	8
DIFFICULTY LEVEL 1 (Time, Speed Plyr's Car)	MEDIUM EASY HARD HARDEST	OFF ON OFF ON	OFF OFF ON ON						
DIFFICULTY LEVEL 2 (Speed Of Other Cars)	MEDIUM EASY HARD HARDEST			OFF ON OFF ON	OFF OFF ON ON		OFF		
STEERING WHEEL	FREE LOCKED					OFF ON			

# UPRIGHT STEERING WHEEL ASSEMBLY

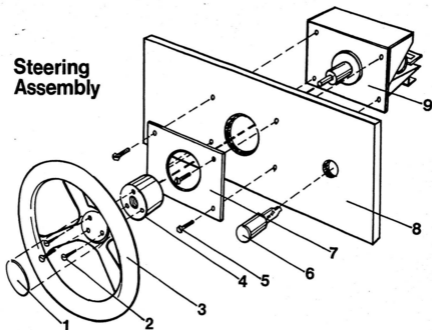

KEY NO.	DESCRIPTION
1	Plastic Cap
2	6mm x 7mm Socket Head Cap Screw
3	Steering Wheel
4	Steering Wheel Hub
5	1/4-20 x 2" Carriage Bolt with 1/4-20 Hex Nut
6	Start Button
7	Trim Plate
8	Control Panel
9	Steering Mechanism Assembly

### SITDOWN STEERING WHEEL ASSEMBLY

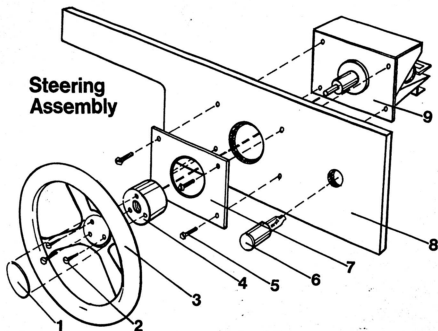

KEY NO.	DESCRIPTION
1	Plastic Cap
2	6mm x 7mm Socket Head Cap Screw
3	Steering Wheel
4	Steering Wheel Hub
5	1/4-20 x 2" Carriage Bolt with 1/4-20 Hex Nut
6	Start Button
7	Trim Plate
8	Control Panel
9	Steering Mechanism Assembly

### LCD. Lens Assembly

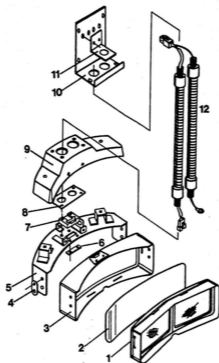

KEY NO.	DESCRIPTION
1	Scope Assembly VO-U41TA
2	Scope Assembly VO-U41TA
3	Scope Assembly VO-U41TA
4	Joint Plate
5	Scope Base
6	Spacer Plate
7	Insulator
8	Spacer
9	Cover
10	Tube Hold Bracket A (Sitdown Only)
11	Tube Hold Bracket B (Sitdown Only)
12	Flexible Harness & Tube Assembly (Sitdown Only)

## COLOR MONITOR SETUP INSTRUCTIONS

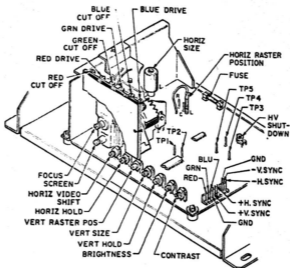

### 1. HORIZONTAL FREQUENCY

With the monitor being driven with the display signal, connect one jumper between TP1 and TP2 and another jumper between TP3 and TP4. Adjust the horizontal hold control until the picture stops sliding horizontally. Remove the jumpers. Do not use the horizontal hold control for horizontal centering. (See #3)

NOTE: If the sync signal is composite, use the horizontal sync input of the same polarity as the composite sync signal.

### 2. PICTURE SIZE

Adjust the vertical size control, and the horizontal width coil for desired picture size.

### 3. PICTURE CENTERING

If the video is off center vertically, turn the vertical raster position control to move the raster up or down. If the video is off center horizontally adjust the horizontal video shift control to center the picture. If any additional horizontal positioning is required, move the horizontal raster position jumper to the left or right position.

### 4. BRIGHTNESS

Adjust the brightness control to obtain the proper illumination. Adjust this control such that the illumination is just barely extinguished from portions of the display which should be black.

### 5. CONTRAST CONTROL

Adjust the contrast control for the desired picture intensity.

### 6. FOCUS

Adjust the focus control for the best overall definition and fine picture detail.

