

Operation, Maintenance,
Service Manual

WARRANTY

Seller warrants that its printed circuit boards and parts thereon are free from defects in material and workmanship under normal use and service for a period of ninety (90) days from date of shipment. Seller warrants that its television monitors are free from defects in material and workmanship under normal use and service for a period of thirty (30) days from date of shipment. None of the Seller's other products or parts thereof are warranted.

If the products described in this manual fail to conform to this warranty, Seller's sole liability shall be, at its option, to repair, replace, or credit Buyer's account for such products which are returned to Seller during said warranty period, provided:

(a) Seller is promptly notified in writing upon discovery by Buyer that said products are defective;

(b) Such products are returned prepaid to Seller's plant; and

(c) Seller's examination of said products discloses to Seller's satisfaction that such alleged defects existed and were not caused by accident, misuse, neglect, alteration, improper repair, installation or improper testing.

In no event shall Seller be liable for loss of profits, loss of use, incidental or consequential damages.

EXCEPT FOR ANY EXPRESS WARRANTY SET FORTH IN A WRITTEN CONTRACT BETWEEN SELLER AND BUYER WHICH CONTRACT SUPERSEDES THE TERMS OF THIS ORDER, THIS WARRANTY IS EXPRESSED IN LIEU OF ALL OTHER WARRANTIES EXPRESSED OR IMPLIED, INCLUDING THE IMPLIED WARRANTIES OF MERCHANTABILITY AND FITNESS FOR A PARTICULAR PURPOSE, AND OF ALL OTHER OBLIGATIONS OR LIABILITIES ON THE SELLER'S PART, AND IT NEITHER ASSUMES NOR AUTHORIZES ANY OTHER PERSON TO ASSUME FOR THE SELLER ANY OTHER LIABILITIES IN CONNECTION WITH THE SALE OF PRODUCTS UNDER THIS ORDER.



This document is and contains confidential trade secret information of Atari, Inc.

This document is loaned under confidential custody for the sole purpose of operation, maintenance or repair of Atari equipment and may not be used by or disclosed to any person for any other purpose whatever, and remains the property of Atari, Inc.

Neither it nor the information it contains may be reproduced, used, or disclosed to persons not having a need to know consistent with the purpose of the loan, without written consent of Atari, Inc.

Table of Contents

Subject	Page		
I. INTRODUCTION	1		
1.1 Physical Description of Game	1	3.4.6 Power Supply	
1.2 Summary of Game Play	1	3.4.7 Player Window Generation	
		3.4.8 Car Picture/Line Sync	
		3.4.9 Projectile RAM s	
		3.4.10 Center Field Objects	
		Picture Line Sync	
II. SPECIFICATIONS	3	3.4.11 Playfield Graphics	
2.1 General	3	3.4.12 Switch Matrix	
2.2 Electrical	3	3.4.13 Generation of Sounds	
2.4 Environmental	3	3.4.14 Start Lamp Drivers	
2.4 Owner/Operator Options for Structuring of Play	3	3.4.15 Audio +18V and +5V Power Supplies	
2.5 Accessories Available on Separate Order	3		
III. THEORY OF OPERATION	5	IV. INSTALLATION INSTRUCTIONS	13
3.1 Functional Description of Game	5	4.1 Unpacking Instructions	13
3.2 General Information	6	4.1.1 Examination for Shipping Damage	
3.2.1 Energizing the Game		4.1.2 Mechanical Inspection	
3.2.2 TV Monitor		4.1.3 Positioning at Game Site	
3.2.3 Picture on TV Screen		4.2 Energizing the Game	13
3.3 Game Sequence	7	4.2.1 Application of AC Power	
3.3.1 Operating Modes		4.2.2 Check on Operation of Interlock Switch	
3.3.2 Attract Mode		4.3 Game Structuring	14
3.3.3 Game Sequence in Play Mode		4.4 Functional Check of Game Operation	14
3.3.4 Owner/Operator Options			
3.4 Detailed Technical Description of Operation	9	V. MAINTENANCE AND ADJUSTMENTS	17
3.4.1 General Comments		5.1 Routine Maintenance	17
3.4.2 Clock Generator, Horizontal and Vertical TV Functions		5.1.1 Cleaning	
3.4.3 Video Summing		5.1.2 Lubrication	
3.4.4 Player PROMs		5.2 Adjustments on TV Monitor	17
3.4.5 Switched Horizontal and Switched Vertical RAM Address Selectors		5.3 Adjustment of Speaker Volume	18

Table of Contents

VI. TROUBLESHOOTING AND REPAIR	19	6.2 Test Equipment	20
6.1 General Procedure	19	6.2.1 Basic Test Equipment	
6.1.1 Identifying the Trouble Area		6.2.2 Optional Test Equipment	
6.1.2 Locating the Trouble Cause		6.3 Specific Troubleshooting Information	22
6.1.3 Correcting the Trouble Cause		6.3.1 Antenna	
6.1.4 Verifying Correct Game Operation		6.3.2 TV Monitor	
		6.3.3 Coin Mechanism	
		VII. SCHEMATICS, DRAWINGS, AND PARTS LISTS	23

I. INTRODUCTION

1.1 PHYSICAL DESCRIPTION OF GAME

Atari's "Cops 'N Robbers" is a car chase video action game for 1, 2, 3 or 4 players. The game is packaged in its own distinctively-styled upright cabinet that rests directly on the floor. Deep inside the cabinet a 23-inch black-and-white TV monitor is mounted with its picture tube facing a mirror. The players stand in front, looking at the TV picture reflected at them by the mirror. Four sets of player controls, one for each player, are provided on the front side of the cabinet. The leftmost set is for the leftmost car in the TV picture, and the rightmost set is for the rightmost car. Each set consists of a foot-operated gas pedal and a hand-operated pistol grip and trigger. Two backlit start push buttons are also mounted on the front of the cabinet. (Drawing number A005590 in Section VII of this manual shows an external view of the cabinet, and drawing number A005604 shows the locations of the start switches alongside the gun control levers.) Several strips of colored transparent material are affixed to the TV picture tube. During game operation these strips filter the white light emitted from the TV tube so that certain portions of the TV picture will appear high-lighted in color. (Drawing number A005726 shows details of these strips.)

Two identical coin mechanisms are mounted below the gun control levers, at the center of the cabinet's front side. The coin mechanisms accept quarters only and are connected so that deposit of coins in either one can initiate game plays. The Cops 'N Robbers game has an owner/operator option that allows selection at the game site of any one of four choices for the cost per play sequence. The cash box is located behind a locked access door to the coin mechanisms. Two speakers are mounted inside the cabinet, one alongside each coin mechanism. During play the speakers produce a variety of sounds that add to the game excitement.

1.2 SUMMARY OF GAME PLAY

In Cops 'N Robbers the players drive cars along parallel, double-lane roadways that appear on each side of the TV picture. The players see the cops, in either one or two cars, on the left, and the robbers, also in either one or two cars, on the right. Each player controls one car and each car has a machine gun barrel that protrudes from the side facing the

opponents. The objective in the game is to build up score points by shooting bullets into the opponent cars.

By pushing his or her gun control lever back and forth, a player can cause the gun barrel on that car to swing to any one of seven angular positions, all of which point in the direction of the opponents. By squeezing the trigger, located near the top of the gun control lever, a player causes bullets to be fired from the gun's barrel. By stepping all the way down on the gas pedal a player causes that car to move upwards along the roadway, from the bottom of the picture toward the top. And by releasing the gas pedal a player causes that car to drop back toward the bottom of the picture.

Besides the car and bullet movements just described, the player's illusion of a car chase is further enhanced by having the dotted-line center divider strips along each roadway simultaneously move from top toward bottom in the picture, and by having one or more beer trucks independently move along the center of the picture, starting from the bottom and going on off the top.

A bullet hitting a car causes that car to roll into a skid/screach motion followed by a crash motion, and finally to disappear off the bottom of the picture. One score point is awarded for each hit made on an opponent car. The accumulated cops score and robbers score are continuously displayed near the top of the picture. There are no restrictions on the total number of bullets fired, but generally the previous bullet must travel off the screen or hit an object before a new bullet can be fired.

After a car has been hit and has disappeared from the TV picture, by stepping all the way down on the gas pedal that player can cause the car to reappear at some random position along the roadway. The car then resumes the game play.

A numerical display of remaining game time appears near the bottom of the picture throughout game play. The number displayed is periodically decremented by one count. When the display reaches zero it means that all the game time has elapsed and the play sequence then ends. The Cops 'N Robbers game features an owner/operator option that allows

selection at the game site of any one of four fixed game times.

The following sounds are produced by the speakers during a play sequence. For the cop cars the left speaker produces a motor idle sound when a gas pedal is released and a motor accelerating sound when a gas pedal is depressed all the way down. The right speaker produces corresponding motor

sounds for the robber cars. Both speakers simultaneously produce these other game sounds: a gun-fire sound whenever a bullet is fired, a zing sound whenever a bullet ricochets, and a screech and crash sound whenever any car is hit by a bullet.

Section III of this manual gives additional details about the game play and about the two owner/operator options.

II. SPECIFICATIONS

2.1 GENERAL

- Cabinet Dimensions: Height 68 $\frac{3}{4}$ inches, Width 41 $\frac{1}{2}$ inches Depth 30 inches.
- TV Monitor: Motorola Model XM701, black-and-white, with 23-inch screen.
- Coin Mechanisms: Two identical mechanisms that operate in parallel; accept quarters.
- Cash Box: Removable; located behind locked access door to coin mechanism assembly.
- Power Cord: Approximately 6 ft. long, extending from bottom rear of cabinet and having grounded three-prong plug for conventional wall outlets.

2.2 ELECTRICAL

- Power Requirement: Game uses conventional wall outlet providing 60 cycle AC (60 Hz, single phase) at 110 volts; power consumption rated at 112 watts.
- Fusing: All fuses located inside cabinet; TV monitor has two 1-amp fuses and remainder of game is protected by a 5-amp slow-blow fuse.

Power Interrupt Switch:

This is a safety switch located inside the cabinet. It interrupts AC power to the game whenever the rear access door is unlocked and opened.

2.3 ENVIRONMENTAL

- Operating and Storage: from 32°F to 120°F (*ambient temperature*)
- Temperature Range: *temperature*
- Relative Humidity: from 0% to 80% *without condensation*

2.4 OWNER/OPERATOR OPTIONS FOR STRUCTURING OF PLAY

- *Cost of Game Play*: adjustable for any of four cost choices, from the least expensive one game per coin (up to four players) choice to the most expensive two coins per player choice.
- *Game Time*: Adjustable for any of four fixed time choices, from a minimum of approximately one minute to a maximum of approximately three minutes.

2.5 ACCESSORIES AVAILABLE ON SEPARATE ORDER

- Video Probe: order from Atari, Inc.
- Universal Test Fixture: order from Atari, Inc., catalog no. TF-101

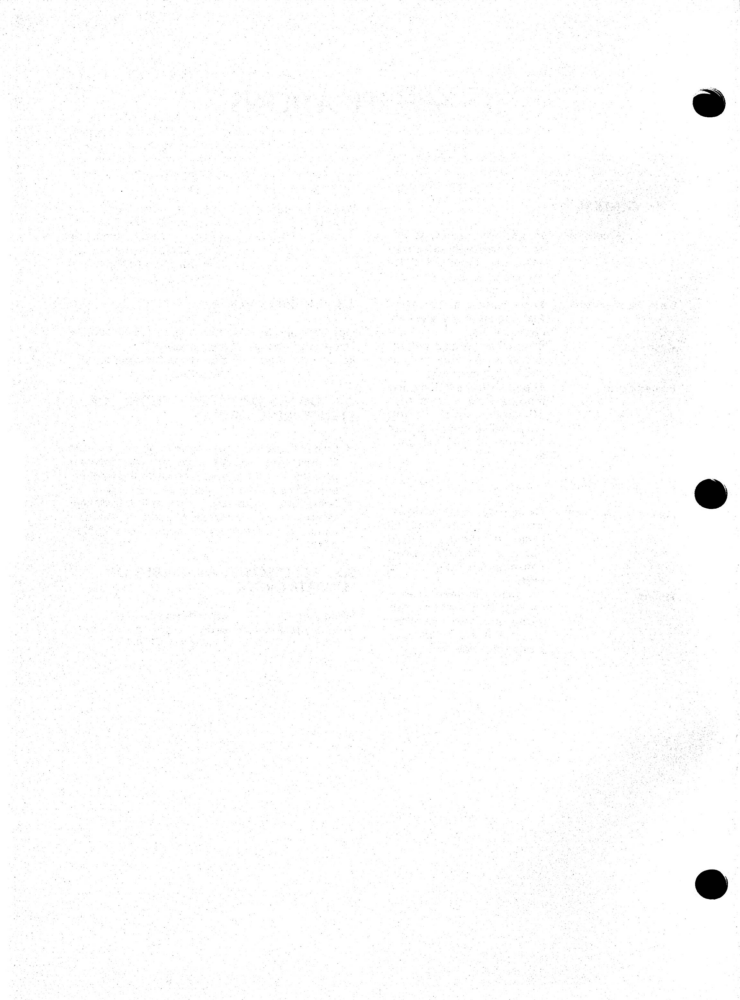

III. THEORY OF OPERATION

3.1 FUNCTIONAL DESCRIPTION OF GAME

The block diagram in Figure 3-1 shows the major functional parts of the Cops 'N Robbers game and

their interconnections. Note that the digital printed circuit board sends a composite video signal to the TV monitor, but that the audio signals to the speakers come from the audio and switch matrix board. No audio signals are produced by the TV monitor.

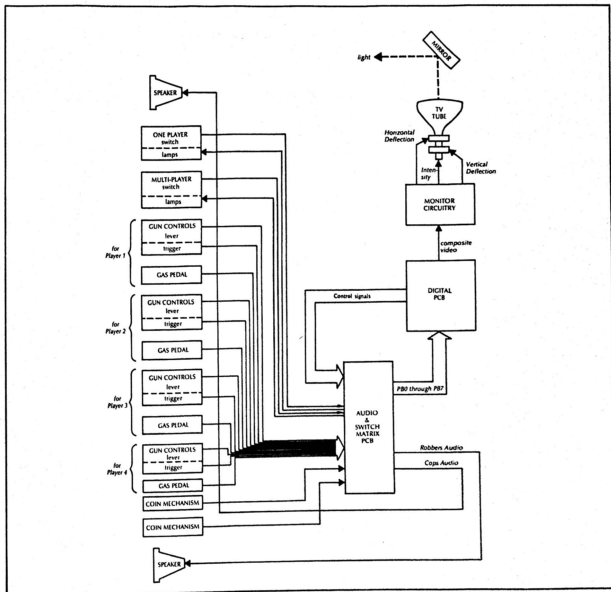

Figure 3-1 Functional Block Diagram of Cops 'N Robbers Game

3.2 GENERAL INFORMATION

The general information about the Cops 'N Robbers game given here provides a background for understanding the Installation Instructions in Section IV of this manual, and the description of game operation in paragraphs 3.3 and 3.4.

3.2.1 ENERGIZING THE GAME: The Cops 'N Robbers game does not have an external "Power On" switch. Instead the game is energized as soon as the power cord is plugged into an active AC wall outlet. This outlet must provide the AC power listed in the Specifications (Section II of this manual).

3.3.2 TV MONITOR: The game's TV monitor is a self-contained transistorized television monitor supplied to Atari by Motorola. Because the composite video signal sent to the monitor by the game control circuitry differs in certain important respects

from the signal derived from commercial TV broadcasts, the picture appearing on the screen is unlike that of a home TV set and the monitor does not produce any sound.

3.2.3 PICTURE SEEN BY PLAYERS: The game's composite video signal is constructed to produce only two video levels (white and black), instead of the more or less continuous shades of gray seen on a home TV screen. Figure 3-2 shows a typical picture that players would see during a play sequence and identifies the objects in it. The picture produced at the face of the TV tube is a mirror reversal of that shown in the figure. Note that the top view of a car is shown when it is capable of moving and firing bullets, but that side views are shown when it is in skid/screch motion and in crash motion. Certain messages written in alphanumeric characters can also appear on the TV picture from time to time during game operation.

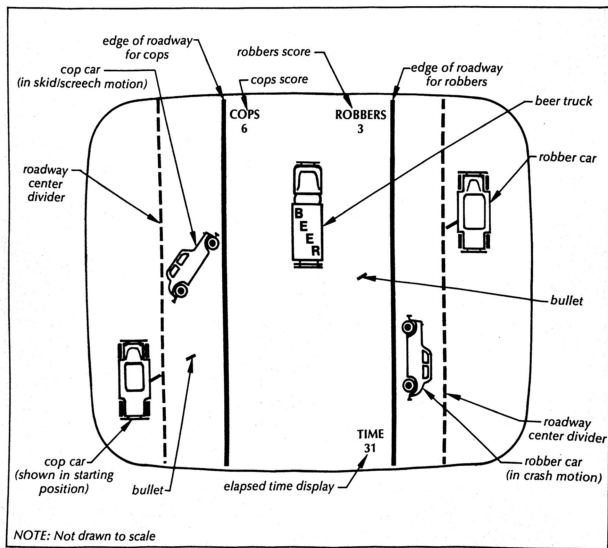

Figure 3-2 Typical Picture During a Play Sequence

3.3.2 ATTRACT MODE: Figure 3-3 shows a typical picture that players would see after completion of a play sequence in the play mode. Just after initial application of AC power, the picture in the attract mode may vary somewhat from that shown in the figure. Also the message line about the cost of game play will be determined by which of the four cost choices has been made. The cops score and the robbers score from the previous play sequence will continue to be displayed throughout the subsequent attract mode. No sounds will be produced, but the cars will be in motion and firing bullets, under automatic control of the game's internal circuitry. The beer truck (or trucks) will also be moving upwards along the center of the picture. However, any hits made on cars will not affect the scores shown during the attract mode.

The lamps behind both start push button do not light during the attract mode, and all player controls are disabled so that operating them produces no response from the game.

3.3 GAME SEQUENCE

3.3.1 OPERATING MODES: During use the Cops 'N Robbers game can be described as operating in either of two modes, attract or play. Plugging the power cord into an active AC outlet energizes the game and it starts out in the attract mode. The game remains in the attract mode until a player deposits a coin and the coin clears the coin mechanism, at which point a signal derived from the coin mechanism causes the game to go into the play mode. The game remains in the play mode until the

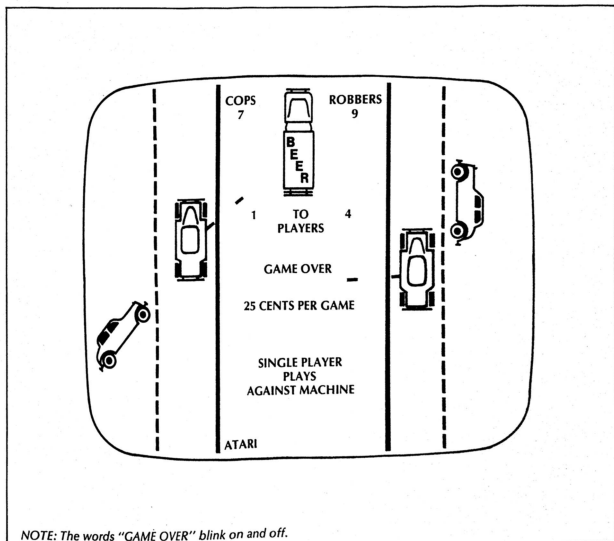

NOTE: The words "GAME OVER" blink on and off.

Figure 3-3 Typical Picture During Attract Mode

game time elapses, at which point it reverts back to the attract mode.

3.3.3 PLAY MODE: A player depositing a coin into either coin mechanism will cause the game to change over to the play mode after the coin clears the coin mechanism. One of the game's responses is to cause the picture to disappear and then to write the following message:

**INSERT COIN FOR MORE PLAYERS
PUSH ONE OR MULTI START**

(The first part of the message will be omitted if the 25 cents per game choice has been selected.) The game's other response is to light the lamps behind the "One Player Start" push button, and, when dictated by the number of coins deposited and the choice of game cost, also to light the "Multi Player Start" button.

To continue the play sequence a player must next depress a lighted start button. The game's first response to this action is to remove the previous message and write the following:

**SINGLE PLAYER CAR ON RIGHT
WHEN CAR HIT
STEP ON GAS PEDAL
CAR APPEARS**

(The first part of the message will be omitted if the "Multi Player Start" had been depressed.) Also the start buttons go dark. This message remains showing for approximately one second after the start button had been depressed. So far in the play sequence no sounds have been produced.

After the one second has elapsed, this message disappears and the game's next response is to produce a picture similar to that of Figure 3-2. Also the participating player controls are now enabled and the game sounds begin to be produced.

Initially both scores will be zero, the elapsed time numerical display will be at the highest count (in accordance with the choice of fixed game time), and cars will all be at the starting positions (at the bottom of the picture). Only the appropriate number of cars will appear.

In a 1-player game both cop cars and the rightmost robber car will appear. (The second robber car is omitted.) The game's internal circuitry automatically controls the cop cars, causing them to fire bullets at the robber car and to "track" the robber car's motion as the player operates its controls to move it along the roadway.

In a 2-player game sequence only the two outermost cars appear—the cop car at the far left and

the robber car at the far right. In a 3-player game sequence three cars appear—the two cop cars and the rightmost robber car. The two players operating the controls for cop cars act as a team against the lone player operating the robber car's controls. In a 4-player game sequence all four cars appear, and the players act as teams, with a cop team playing against a robber team.

The players operating the two outermost cars must take care not to fire a bullet into the team partner's car as it passes in front of the rifle barrel. If this does happen the result is the same as a hit by an opponent's bullet—the hit car goes into a skid/screech motion and one point is added to the opponent's accumulated score. To offset this disadvantage the game's design allows bullets fired from either of the outermost cars to ricochet once when the bullets hit the upper or lower edge of the picture. This game feature means that outermost cars can fire bullets "around" their partners and still make hits on opponent cars. Bullets fired by the innermost cars are not allowed to ricochet.

Beer trucks serve as obstacles because bullets fired into them are absorbed, thereby providing increased difficulty to the game play. And more beer trucks are added as higher score levels are achieved. Specifically, only one beer truck appears as long as both accumulated scores are 9 points or less. But as soon as either score reaches 10 points, a second beer truck is added. A third beer truck is added as soon as 20 points is reached, and a fourth is added at 30 points.

3.3.4 OWNER/OPERATOR OPTIONS: The Cops 'N Robbers game has two options which the owner/operator can adjust at the game site in order to structure the play sequence, that is to change some of the game rules or the duration of play. Paragraph 4.3 in Section IV of this manual gives detailed instructions for adjusting these options. The game also has a separate volume adjustment for each speaker; refer to paragraph 5.3 in Section V.

(a) *Cost of Game Play.* This option consists of setting the positions of two on/off switches. Four choices are provided, as follows: 25 cents/game (least expensive, for as many as four players); 2 players for 25 cents; 25 cents/player; and two coins (50 cents) per player (most expensive).

(b) *Game Time.* This option consists of setting the positions on two other on/off switches. Again four choices are provided, as follows: 1 minute (shortest game time); 1 minute 45 seconds; 2 minutes 20 seconds; and 3 minutes (longest game time).

3.4 DETAILED TECHNICAL DESCRIPTION OF OPERATION

3.4.1 GENERAL COMMENTS: Nearly all the game's circuitry is contained on two game printed circuit boards, an audio and switch matrix PCB and a digital PCB housed in a perforated metal box enclosure, and in the TV monitor. Other components that connect to this circuitry include the coin mechanisms, speakers, four sets of player controls, and the start push buttons.

This subsection of the manual gives technical descriptions of game circuitry regarded as field-repairable. Correction in the field of trouble causes traced to certain portions of the circuitry on the digital PCB may require replacement of the entire board. The drawings included in Section VII of this manual supplement the text given here. Drawing number 005625 is a schematic of the digital PCB and A005625 is a board assembly drawing that shows locations of components called out on the schematic. Likewise drawing numbers 005627 and A005627 are the schematic and assembly drawing for the audio and switch matrix PCB. Drawing number 005718, the harness schematic, shows the wiring interconnections between the two PCBs, player controls and other components.

On the digital PCB and on its schematic each integrated circuit device location is identified by a column letter designation (A through R) and a row number designation (1 through 9). A similar method of identification is used on the audio and switch matrix PCB.

On the PCB schematics the symbol "P" (appearing at various inputs to logic gates and other integrated circuits) indicates a connection to +5 volts through a pull-up resistor.

In the subparagraphs that follow the portions of the circuitry being described can be located on the PCB schematic by finding the intersection of the zone letters (A, B, C or D) and the zone numbers (1 through 8). For example, the designation "Sheet 1, Zone A8" refers to the extreme lower left corner of sheet 1 of the schematic.

NOTE: Subparagraphs 3.4.2 through 3.4.11 apply to the digital PCB; refer to the schematic on drawing number 005625.

3.4.2 CLOCK GENERATOR, HORIZONTAL AND VERTICAL TV FUNCTIONS (LEFT HALF OF SHEET 2): The output of a 14-MHz crystal-controlled oscillator is divided down by counter P9 to produce the

CLOCK signal at P9 pin 12. CLOCK is used to drive the counter chain formed by P8, N8 and L8, and also for basic timing elsewhere on the board. The counter chain produces the horizontal timing signals 1H, 2H, etc. Certain of these are decoded to produce the \overline{H} RESET signal once for each line on the TV picture. H RESET drives a second counter chain formed by B5, C5 and L8, which produces the vertical timing signals 1V, 2V, etc. Two of these signals are decoded to produce the \overline{V} RESET signal once per TV picture frame.

The horizontal timing signals are applied to the PROM device in location N4 to produce the horizontal blanking signal H BLANK PR. Likewise the vertical timing signals are applied to PROM D5 to produce the V BLANK signal. Flip-flop A5 in Zone A8 and the type-74174 device in location M8 are added for deglitching of the signal timing. The \overline{H} SYNC signal produced at M8 pin 12 is gated with \overline{V} SYNC at exclusive OR M4 to produce COMP SYNC (composite sync), which contains the synchronization information for the TV monitor.

The picture information for the TV monitor is derived from the following four separate signals applied to M8:

- \overline{CFO} OUT (centerfield objects out) for the beer truck component
- $\overline{PROJECTILES}$ for cops and robbers bullets component
- $\overline{PLAYERS}$ OUT for cop cars and robber cars component
- $\overline{GRAPHICS}$ OUT for alphanumeric character component (score displays, elapsed time display, messages).

The corresponding four outputs produced at M8 pins 2, 5, 7 and 10 pass through individual contacts inside switch SW1, and then are combined at gate M6 to produce the POS. VID. (positive video) signal. Switch SW1 is provided for use during board troubleshooting only, so that one or more picture components can be manually switched out. However during normal game operation this switch should be left in the positions with all contacts closed. Switch SW2, which connects the V BLANK signal to resistor R27 and gate F9, is also provided for troubleshooting purposes, and should be left in the closed position during normal game operation.

3.4.3 VIDEO SUMMING (SHEET 2, ZONES C 7 & 8): The junction of diode CR4 and resistors R40 and R41 forms the video summing point. Gate E2 combines the blanking, positive video and a race eliminate signal to produce the picture information contribution. This contribution is coupled via R40, and the synchronization information contribution is coupled via the diode. The composite video signal is sent out on edge-conductor pin M and, via the wire harness, over to the TV monitor.

3.4.4 PLAYER PROMS (SHEET 2, ZONES C4 & D4): The four PROMs in locations P1, M1, L1 and J1 are programmed with the pictures of the player cars. There is a total of 16 pictures, as follows: 7 cop car pictures (one for each different rifle position), 7 robber car pictures (also one for each different rifle position), one skid/screech car picture, and one crash car picture. The type-9321 2-line to 4-line decoder device in location P2 determines which of the four PROMs is to be enabled.

The type-9312 device in location F1 multiplexes the outputs from the car PROMs to produce a single PLAYERS OUT signal that contains the car picture information in serialized form.

3.4.5 SWITCHED HORIZONTAL AND SWITCHED VERTICAL RAM ADDRESS SELECTORS (SHEET 2, ZONES A5 & B5): The four type-9322 2-line to 1-line data selector devices in locations P6, N6, B4 and C4 produce the SH0 through SH7 and SV0 through SV7 signals. These are the switched horizontal and switched vertical functions used for addressing the projectile RAMs (see sheet 3, Zones C, D 3 & 4), the player window RAM (sheet 3, Zone D8), and for other purposes.

3.4.6 POWER SUPPLY (SHEET 2, ZONES C, D 1 & 2): The 16.5 VAC taps from the power transformer connect to diode rectifiers and then to a power supply circuit formed by an LM323 amplifier. This supply produces the +5 volts used on the digital PCB.

3.4.7 PLAYER WINDOW GENERATION (SHEET 3, ZONES C8 and D 6, 7, 8): In the TV picture each car always travels on a straight-line path along its own roadway. Since the cars are not allowed to make turns off the roadway, a unique vertical slot in the picture is obtained for each car merely by decoding the 32H, 64H and 128H signals. This is done at gates F2, E1, D1 and E2. The component of the car's position up and down the roadway is obtained by applying the switched horizontal signals SV0 through SV7 to the RAM device in location C3. These two position components, the car's vertical slot and its position up and down the roadway, are combined in gates C2, D3, and D2, and then further synchronized with the 256H signal and the output of flip-flop A5 to produce the PLAYER WINDOWS signal. The timing of this signal determines when car pictures are to appear.

3.4.8 CAR PICTURE/LINE SYNC (SHEET 3, ZONES C 5, 6, 7 and D5): The type-74170 devices in locations J3 and F3, and the type-7483 devices in J2 and H2, perform the function of resynchronizing each car picture with its vertical position on the TV screen so that the front of a car always appears as the first line of the car picture, and the rear of the car in the last line. The type-74170 device in location H3 produces four signals that, when decoded, will determine

which of the 16 car pictures are to be read out at any one time.

3.4.9 PROJECTILE RAMS (SHEET 3, ZONES C, D 3 & 4): The bullet projectiles are considered as high-resolution objects because they can appear anywhere in a 256-bit by 256-bit matrix on the TV screen. For this reason, both horizontal and vertical position decoding must be performed for each bullet.

RAM devices L5, M5, N5 and P5 are addressed by the switched horizontal functions SH0 through SH7. Gate B2 produces a signal for each car's bullets (B2 pins 11, 8, 6 and 3). All four of these signals are then combined and synchronized with 256H to produce the PROJECTILES signal. It contains the bullet picture information in serialized form.

3.4.10 CENTER FIELD OBJECTS PICTURE LINE SYNC (SHEET 3, ZONES A, B 1 & 2): In this game the beer trucks appear as the center field objects. The type-74170 devices in locations K3 and L3, and the type-7483 devices in K2 and L2 resynchronize the beer truck pictures so that the front of a truck always appears on the first line of the beer truck picture, and the rear of the truck in the last line. The unique vertical slot in the center of the TV screen through which the beer trucks always travel is produced by decoding of the 8H through 128H timing signals. The RAM in location A3 determines where each beer truck will appear along the path running from the bottom to the top of the screen.

PROM M2 is programmed with the beer truck pictures. The type-9312 device in location N2 multiplexes the PROM outputs to produce the CFO OUT signal that contains beer truck picture information in serialized form.

3.4.11 PLAYFIELD GRAPHICS (SHEET 3, ZONES A 3 THROUGH 8): The alphanumeric characters on the TV screen are considered as low-resolution objects because they can appear only in a 32-character by 26-character location matrix approximately centered on the TV screen. Each character is formed in an 8-bit by 8-bit block. The various characters have been programmed in the PROM device in location M3. The position where the character is read out on the TV screen is determined by a RAM register array that produces the addressing inputs to the PROM. The RAM devices in locations L4, K4, J4, H4, F4 and E4 form this register. The timing signals 1V, 2V and 4V also address the PROM M3, so that the bar segments forming the characters are read out in a proper sequence.

The RAM devices in the RAM register are addressed by the PG0 through PG9 signals produced by the type-9322 2-line to 1-line data selector device in locations L6, F5 and E5. The type-9312 device in

location P3 multiplexes the character PROM's outputs to produce the GRAPHICS OUT signal that contains the alphanumeric information in serialized form.

NOTE: The remaining subparagraphs apply to the audio and switch matrix PCB; refer to the schematic on drawing number 005627.

3.4.12 SWITCH MATRIX (ZONES C, D 1 THROUGH 3): The three signals ADR2, ADR3 and ADR4, coming from the digital PCB, are applied to the type-74145 BCD-to-decimal decoder device in location B1 to produce eight separate output signals. These signals connect to load resistors and, via the harness wiring, to the common contacts of the switches of the player controls mounted on the front of the cabinet. With this arrangement each of the eight signals can pass through as many as eight switch contacts, for a possible total of 64 in all. However, less than 60 are actually used on this game. A summary of the connections is given in tabular form in Zone B1 of the schematic, and all wiring connections to the switch contacts are shown on the harness schematic, drawing number 005718.

The second contact in each switch contact pair connects to an individual diode; all the diodes are mounted on the board. The diode designations start at CR1 and can go up to CR64, although less than 60 are actually used here. The anodes of the diodes are connected together in groups of eight, to produce the signals P80 through P87. These eight signals are sent over to the game control circuitry on the digital PCB.

With this diode switch matrix, the game control circuitry continually "interrogates" the state of switches on the player controls, so that every player action (depositing a coin, depressing a start button, moving a gun control lever, depressing or releasing a gas pedal), will be promptly sensed and the game produces the correct responses. Note that the states of the cost and game time structuring switches (S37 through S40) are also being sensed.

The energizing coil of the electromechanical coin counter mounted inside the coin mechanism assembly is shown in Zone B3 of the schematic. Each time a coin passes through a coin mechanism a current pulse is sent through the coil and the counter increments by one count.

3.4.13 GENERATION OF SOUNDS (LEFT HALF OF SCHEMATIC): Each speaker can produce six different sounds. The ricochet sound is derived from the ZINGS signal coming from the digital PCB, and the gunfire sound from the FIRES signal which also

comes from the digital PCB. The remaining sounds are derived from the outputs of the type-9334 device in location H3. The input signals applied to this device also come from the digital PCB. The MOTOR 0 and MOTOR 3 signals are applied to pairs of car motor sound generator circuits. One circuit in each pair produces the "idling" sound, and the other circuit in the pair produces the "accelerating" sound.

The 1V signal coming from the digital PCB is used to drive a noise generator configuration formed by the type-74164 devices in locations J2 and H2 (Zone C5 of schematic). The NOISE 1 output signal from the noise generator is used in the circuit that produces the skid/screech sound (in Zone D5), and the NOISE 2 is used in the circuit that produces the gunfire sounds (in Zone A7). The ZINGS signal drives the circuit that produces the ricochet sounds (in Zone B6). The output from this circuit is summed through resistor R33 with the output from the gunfire circuit, via resistor R43. This summing point provides the input for the amplifier that produces the FZ (fire-zing) signal in Zone B6.

The crash sound generation circuit in Zones C4 and C5 produces a crash signal separately for each car (at gate L3 pins 8, 11, 6 and 3), and these four signals are then summed together through resistors to produce one CRASH OUT signal.

In Zone A5 and B5 the sounds for the robbers are all summed together via resistors R12, R61, R64, R83 and R84. Potentiometer R92 provides one of the speaker volume adjustments described in Section V of this manual, and the potentiometer then connects to the TDA 1004 amplifier that drives the right speaker.

In Zones A4 and B4 the sounds for the cops are likewise summed together. Potentiometer R93 provides this speaker volume adjustment and the TDA 1004 amplifier drives the left speaker. Note that motor sounds are produced independently for cop cars and for robber cars, but that the remaining four sound signals are common to both speaker circuits.

The AUDIO ENABLE signal, produced at H3 pin 12 in Zone B7 of the schematic, disables both sound output circuits so that sounds can only be produced during a play sequence and not in the attract mode.

3.4.14 START LAMP DRIVERS (ZONE D 3 & 4): The ONE START signal, produced at H3 pin 11 in Zone B8 of the schematic, brings transistor Q6 into conduction, causing the lamps behind the "One Player Start" push button to light up, after a player has deposited a coin in the game. In a similar fashion the MULTI-START signal, coming from the digital PCB, brings transistor Q7 into conduction, causing the lamps behind the "Multi-Player Start" push button

to light up, after players have deposited a sufficient number of coins to pay for a multi-player game.

3.4.15 AUDIO +18V AND +5V POWER SUPPLIES (ZONE A8): The 25 VAC taps from the power transformer are connected to diodes CR70 and CR71, which act as a full-wave rectifier to produce an un-

regulated +18 volts DC. This supply voltage is used by the TDA 1004 amplifier devices that drive the game's two speakers.

The 16.5 VAC taps from the power transformer connect to diode rectifiers and then to a power supply circuit formed by an LM309 amplifier. This supply produces the +5V used on this board.

IV. INSTALLATION INSTRUCTIONS

4.1 UNPACKING INSTRUCTIONS

4.1.1 EXAMINATION FOR SHIPPING DAMAGE: Before shipment from the factory, components and sub-assemblies of each game are carefully checked for proper operation. However, during shipment some adjustments may have changed or parts may have been damaged. Upon initial removal of the game from the shipping container, first examine the exterior of the cabinet. Then open the rear (or side) access panel and also examine the interior. Any shipping damage such as a dented, cracked or broken cabinet, sub-assemblies broken loose, etc., should be reported immediately to the shipper and to Atari, Inc.

4.1.2 MECHANICAL INSPECTION: After determining that the game has been received in good condition, carefully inspect the interior parts and verify the following:

- (a) All slip-on and plug-in connectors are firmly seated (particularly the PCB edge connector)
- (b) The fuses are all seated in their holders
- (c) No loose foreign objects are present (especially metal objects which could cause electrical short circuits)
- (d) No harness wires have become disconnected or pulled loose.

Be sure *all* major assemblies have been checked: the transformer and other components on the electronics tray assembly, the two coin mechanisms, the speakers (only one on upright cabinet version), the player controls and start push button switches, and the TV monitor chassis.

Do not go on to the remaining paragraphs in this section until the above mechanical inspection has been thoroughly performed.

4.1.3 POSITIONING AT GAME SITE: When moving the game cabinet into its final position at the game site, *do not* push the cabinet up snug against a wall, storage cabinet or any other large flat surface. An unobstructed air space of 12 to 18 inches must be left behind the cabinet. Doing this will insure a free air flow for the cooling fan mounted at the bottom rear inside the cabinet.

4.2 ENERGIZING THE GAME

4.2.1 APPLICATION OF AC POWER: Close and lock the rear access panel, making sure that it is completely shut at the bottom, and remove the key from the lock. Then plug the power cord into an AC outlet providing the AC power listed in the Specifications (Section II of this manual). The wall outlet must accept a three-prong plug and the receptacle must be connected to a good earth ground.

After the power cord has been plugged in, the proper response from the game is that a picture appears on the TV screen.

If there is no response at all from the game, unplug the power cord and check the AC wall outlet. A simple, safe way to check for presence of AC power at the wall outlet is to plug in an appliance known to be working properly—such as a table lamp, radio, or an electric clock. If the wall outlet passes the check, then presume that the trouble is with the game and refer to Section VI of this manual.

CAUTION: No troubleshooting steps should be attempted inside the cabinet by anyone not familiar with safety measures and repair procedures on electrical equipment.

Do not go on to the remaining paragraphs in this section until the proper response described above has been observed.

4.2.2 CHECK ON OPERATION OF INTERLOCK SWITCH: The interlock switch is a safety switch mounted inside the game cabinet. At the factory this switch is mechanically adjusted so that it will automatically transfer to its "off" position (switch contacts "open") whenever the panel is opened. When the interlock switch is in its "off" position, the AC power leading to the game's power supply is interrupted. When the panel is closed, the interrupt switch is adjusted to be in the "on" position (switch contacts "closed") and AC power is allowed to reach the game's power supply, meaning that the game can operate.

After application of AC power per paragraph 4.2.1 above, correct operation of the access panel

interlock switch can be checked as follows: unlock and slowly open the panel. The correct response is that by the time the edge of the panel has moved about 2 to 3 inches away from the cabinet the TV screen should go dark, verifying that the interlock switch has automatically transferred to "off." While opening the panel do not insert fingers inside the cabinet and do not allow foreign objects to fall inside. If the TV screen continues to be lighted up even after the panel has been opened, immediately close and lock it and unplug the power cord from the wall outlet. Then refer to Section VI of this manual to replace and/or adjust the interlock switch.

Do not go on to the remaining paragraphs in this section until the operation of all interlock switches has been checked and found to be correct.

4.3 GAME STRUCTURING

Before putting the game into operation at the game site, the game structuring should be defined by the owner/operator. The term "game structuring" refers to the game rules and the duration of the play sequence. Paragraph 3.3.4 of Section III in this manual covers the owner/operator options featured in this game and describes how they affect the game structuring.

In the Cops 'N Robbers game all structuring is accomplished by selecting "on" or "off" positions on four switches of a miniature switch assembly. This switch assembly is mounted on the audio and switch matrix PCB inside the game cabinet. Adjustment of the switch positions is done by hand, as described below.

Before performing any adjustment, the game should be de-energized or not operating. Further, it is also recommended that the power cord be unplugged beforehand.

Unlock and open the rear panel access door; doing this should cause the interlock switch to de-energize the game, as described in paragraph 4.2.2. If the switch fails to de-energize the game, immediately close and lock the door, unplug the power cord, and refer to Section VI of this manual to adjust and/or replace the switch.

While being careful to avoid touching any parts of the body against the TV chassis components or other wiring connections inside the cabinet, find the audio and switch matrix PCB near the lower right corner of the cabinet. Examine the board's surface and compare it with the drawing shown in Figure 4-1.

The miniature switch assembly is located in the left corner of the board near the 86-pin edge connector. The switch numbers (1 through 4) are engraved or embossed on the switch body. The direction of a switch's "on" position is also indicated in a similar fashion on the switch body. Table 4-1 summarizes the structuring set up by all the possible combinations of switch settings.

After adjusting the switches to obtain the desired structuring, close and lock the rear door and energize the game.

Table 4-1 Cost and Game Time Structuring

SWITCH NUMBERS AND POSITIONS		STRUCTURING
#1	#2	
<i>on</i>	<i>on</i>	Cost is 25¢ per player
<i>on</i>	<i>off</i>	Cost is 2 players for 25¢
<i>off</i>	<i>on</i>	Cost is 25¢ per game (up to 4 players) (least expensive choice)
<i>off</i>	<i>off</i>	Cost is 2 coins (50¢) per player (most expensive choice)
#3	#4	
<i>on</i>	<i>on</i>	Game Time is 1 minute (minimum time) and Elapsed Time Display counts down from 30
<i>on</i>	<i>off</i>	Game Time is 1 minute 45 seconds and Elapsed Time Display counts down from 50
<i>off</i>	<i>on</i>	Game Time is 2 minutes 20 seconds and Elapsed Time Display counts down from 70
<i>off</i>	<i>off</i>	Game Time is 3 minutes (maximum time) and Elapsed Time Display counts down from 90

4.4 FUNCTIONAL CHECK OF GAME OPERATION

The following procedure provides a simple check that can be quickly performed at the game site and that does not require external test equipment. If at any point during this procedure the game's response is found to be other than that called for herein, assume the game is not operating correctly and

refer to Section VI of this manual. If responses are as described here then assume that major parts of the game are operating correctly.

First perform the adjustments described in paragraph 4.3, Game Structuring, and then energize the game per paragraph 4.2. Just after application of AC power a picture should be produced by the TV monitor and the game should be operating in the Attract mode, as per subparagraph 3.3.2.

NOTE: Sometimes upon initial application of power (or, more rarely, later on during play) the TV monitor may produce a "scrambled" picture. This irregularity happens if the game's internal circuitry has not initialized itself. Although normally taken care of automatically, it is possible that severe noise spikes on the AC power line could upset the self-initialization. Generally a scrambled picture can be corrected by de-energizing the game and then re-energizing it, one or more times. Do this either by unplugging the power plug from the wall outlet and reconnecting it, or else by opening and closing the cabinet's rear door so that the interlock safety switch is exercised.

4.4.1 CHECK OF ATTRACT MODE: No sounds should be produced during the attract mode. The

picture should resemble the one shown in Figure 3-3, but certain variations may be noted. For example, the number of beer trucks may vary, and random numerals may be showing in the score displays. During this mode both start push buttons should be not lighted, and all player controls should be disabled. Operation of any of the controls should not produce any response from the game.

4.4.2 CHECK OF PLAY MODE: After correct game operation in the attract mode has been verified, deposit a coin in one of the coin mechanisms. (If the game cost owner/operator option has been set for two coins per player, it will be necessary to deposit a second coin also.) As soon as the coin(s) have been accepted, the game should respond by changing over to the play mode, as described in subparagraph 3.3.3 of Section III. Confirm that the cars picture disappears and is replaced by a message picture. Also confirm that one or both start push buttons light up, in accordance with the choice of Game Cost structuring made.

Next depress the lighted "One Player Start" push button. The game should respond, as described in subparagraph 3.3.3, by showing a new message for one second followed by a cars picture and game sounds. Operate the rightmost set of player controls to confirm that they control the motion and fire bullets for the one robber car appearing in the picture. The other three sets of player controls

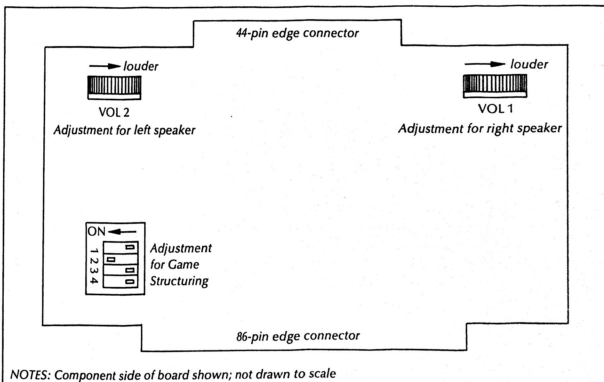

NOTES: Component side of board shown; not drawn to scale

Figure 4-1 Adjustments on Audio and Switch Matrix PCB

should be disabled because the game's internal circuitry is controlling motion of the cop cars. Observe the various objects in the picture (score displays, elapsed time displays, beer truck, etc.) and confirm that the play sequence continues as described in subparagraph 3.3.3, including the various game sounds produced by both speakers.

After all the game time elapses, the game should change over to the attract mode. Final scores from the previous play sequence should remain showing however.

For the remainder of the function check deposit one or more coins into the other coin mechanism and exercise the game for 2-, 3-, and 4-player play sequences.

As the final step in the functional check make sure that 12 to 18 inches of unobstructed air space has been left behind the game cabinet; there must be free air flow for the cooling fan mounted at the bottom rear inside the cabinet.

V. MAINTENANCE AND ADJUSTMENTS

5.1 ROUTINE MAINTENANCE

Due to its solid-state electronic circuitry, this Atari game should require very little maintenance and only occasional adjustment.

5.1.1 CLEANING: Game cabinets and glass may be cleaned with any non-abrasive household cleaner. If desired, special coin machine cleaners which leave no residue can be obtained from distributors.

5.1.2 LUBRICATION: About once every three months lightly spray the rejector linkage portion of the coin acceptor inside each coin mechanism. Use WD-40® or similar lubricant, and avoid spraying the entire coin acceptor. Potentiometer shafts must never be lubricated in any way.

5.2 ADJUSTMENTS ON TV MONITOR

The TV monitor need be adjusted only when the picture is distorted, or if the contrast or brightness seem out of adjustment.

NOTE: The TV monitor is accessible only from inside the game cabinet and these adjustments have to be done while the game is energized. Therefore only persons familiar with safety measures and repair procedures on electrical equipment should perform them.

The monitor's adjustments function like those of a conventional commercial television set, except that the volume adjustment has no effect. Instead the game produces its sound in a speaker separate from the TV monitor. Figure 5-1 shows the location of the adjustments on the rear of the chassis. When making the adjustments follow these general guidelines:

BRITE (Brightness)—Perform this adjustment before the contrast. Adjust so that the white lines

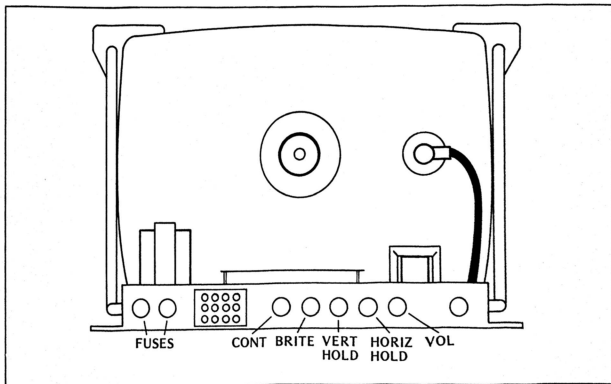

Figure 5-1 Location of Adjustments on TV Chassis

covering the screen just barely disappear, when the brightness is turned up.

CONT (Contrast)—Adjust so that the images are as bright as possible against the dark background without being blurred.

HORIZ HOLD (Horizontal Hold)—Adjust if the picture is slightly off-center horizontally, if the images appear warped, or if the picture is broken up into a series of diagonal lines. Adjust for a stable, centered picture.

VERT HOLD (Vertical Hold)—This needs adjustment only if the picture appears to be rolling up or down the screen. Adjust for a stable, centered picture.

5.3 ADJUSTMENT OF SPEAKER VOLUME

The electronic drive circuitry for the speakers has two independent adjustment potentiometers so that the volume level of sounds produced by each speaker can be separately adjusted. These potentiometers are both mounted on the audio and switch matrix printed circuit board inside the cabinet. They can be adjusted manually by following the procedure given below.

Unlock and open the rear door of the cabinet; doing this should cause the interlock switch to de-energize the game, as described in subparagraph

4.2.2. If the switch fails to de-energize the game, immediately close and lock the door, unplug the power cord, and refer to Section VI in order to replace and/or adjust the switch.

While being careful to avoid touching any parts of your body against the TV chassis components or other wiring connections inside the cabinet, find the audio and switch matrix PCB near the lower right corner of the cabinet. Examine the board's surface and compare it with the drawing shown in Figure 4-1 in Section IV of this manual.

The potentiometers are located near the corners of the 44-pin edge connector end of the board. The words "VOL 1" are engraved on the surface of the board alongside the potentiometer that controls volume for the right speaker, and "VOL 2" alongside the potentiometer for the left speaker. Figure 4-1 shows the approximate locations of the potentiometers; their exact locations are shown on drawing number A005627 with the designations R92 and R93, respectively.

To cause a speaker to produce louder sounds, with your finger move the stud on top of the potentiometer body in the direction shown by the arrows in Figure 4-1. For quieter sounds move the stud in the opposite direction.

After performing these adjustments close and lock the rear door and energize the game.

VI. TROUBLESHOOTING AND REPAIR

6.1 GENERAL PROCEDURE

NOTE: This section describes troubleshooting procedures in detail sufficient for a person with moderate technical ability to understand. However, for those interested in gaining more information on video game technology, especially the electronics, we recommend reading the Video Game Operator's Handbook, manual no. TM-043. This book is available from Atari, Inc., attn. Customer Service Dept., 2175 Martin Avenue, Santa Clara, CA 95050 for \$5.00 each, or from your distributor.

6.1.1 IDENTIFYING THE TROUBLE AREA: The first troubleshooting step should be to note all observable trouble symptoms. Examples of symptoms are: depositing a coin produces no game response, no sound coming out of the speaker at any time, no picture on the TV screen. At the same time also note the game features that still work. A systematic way of checking game operation is to perform the functional check given in Section IV of this manual. Carefully train your eye to pick up all clues; by doing this an experienced troubleshooter can often spot the cause of a trouble even before he opens the cabinet.

Keeping these observations in mind, use the understanding of game operation gained from the theory of operation (Section III) and the schematic drawings (Section VII). Next narrow down the suspected cause of the trouble to a specific area or areas of the game: the coin mechanism, TV monitor, harness and front panel components (switches, lamps, gun control levers, gas pedals), electronics tray, printed circuit boards and power cord. Be careful not to overlook possible trouble areas that may seem too obvious: a power cord plug that has worked loose from the wall outlet and is no longer fully seated in the receptacle, or a rear panel access door that is not fully closed (thus causing the interrupt switch to block the AC power path to the game).

6.1.2 LOCATING THE TROUBLE CAUSE: Once a problem has been narrowed down to one or more areas, the next step is to perform various tests and

measurements to isolate a specific cause of the trouble. Remember that sometimes a very complicated problem, such as erratic game operation, can be traced to a simple cause—the printed circuit board not being fully seated in its edge connector. Start with the most suspect area and trace backwards from the point where the trouble is first observable, using a process of elimination to eventually locate the faulty component, connection, etc. For example, if no sound is audible during game play, first check for a signal at the speaker leads. If no signal is present there, go back through the wiring harness connections to the printed circuit board. If there is still no signal, then systematically check back through the various components of the sound generation circuit.

Substitution of parts is a legitimate and easy way to isolate the cause. For instance, if the PCB is the suspected trouble area, remove it and substitute a known-to-be-good PCB. Then check for correct game operation. Similarly, to check the TV monitor, connect the game to a known-to-be-good monitor. The harness can often be checked by substitution also. Substitute both a known-to-be-good PCB and TV monitor. If the trouble still persists, the harness must be at fault.

While locating the trouble cause, use the technical descriptions in Section III as guides for correct circuit-level operation, and the schematic drawings of Section VII as roadmaps for tracing signal flow paths.

The test equipment for use in troubleshooting is discussed in paragraph 6.2.

6.1.3 CORRECTING THE TROUBLE CAUSE: In practice, the steps required to correct troubles can range from simple adjustments (fully seating the PCB in its edge connector, changing the setting on a potentiometer, adjusting the picture controls on the TV monitor) to repair of loose connections and replacement of defective parts. Extreme care should be exercised when removing integrated circuit devices and discrete components. Use a 40-watt soldering iron with a small tip designed especially for IC work. To remove an IC device, follow this procedure:

Clip all leads and lift the IC package out, leaving two rows of leads. Then remove leads individually with a soldering iron and needle-nose pliers. Finally, evacuate the holes with a solder sucker. Afterwards clean the area thoroughly, using an approved PCB cleaning solution to remove any traces of flux and dirt. Alcohol will do in a pinch, if necessary.

Insert the new IC device using an IC insertion tool, making sure that the reference notch is oriented correctly and that the device's leads are not bent during insertion into the board. Afterwards, be sure to solder each lead on *both* sides of the PCB, using as little solder as possible. After soldering, clean the area thoroughly to remove the flux.

Observe the same removal and insertion procedures when replacing discrete components. Trim the leads as close as possible and be sure to orient diodes and capacitors correctly.

6.1.4 VERIFYING CORRECT GAME OPERATION:

After locating and correcting the cause of a trouble, re-energize the game and perform a final check on correct game operation. Doing this will verify that your troubleshooting was correct. If the game operation is still not correct, go back and double-check your work. Make sure that any replaced components were installed correctly. If this was done properly, then start the troubleshooting steps over again. Keep in mind that there may be more than one trouble at a time, and that correcting one trouble can sometimes bring previously undetectable troubles to light.

This verification is especially important when the original trouble had been intermittent, that is, was not happening all the time.

6.2 TEST EQUIPMENT

Electronic troubleshooting of a video game essentially consists of checking for the presence of various signals and of examining their condition. A signal can be thought of as acting like a "messenger" that carries instructions from one unit or circuit to another. Many different types of signals are produced in a video game, and for this reason several unusual and perhaps unfamiliar types of test instruments are used during troubleshooting. Each instrument has its own set of advantages and disadvantages for examining a given type of signal, and both the depth of the intended troubleshooting capability and budget will determine what instruments will be needed. Some instruments are basic and essential, no matter what size of service facility, while other optional instruments are desirable because they make troubleshooting easier and quicker.

6.2.1 BASIC TEST EQUIPMENT:

(a) *The Video Probe.* This is a simple but invaluable instrument having two leads—a test-clip lead and a test-probe lead. During troubleshooting of video signals the test-clip lead is left connected to the game side of the video coupling capacitor. On the Cops 'N Robbers game this point is the junction of resistors R40 and R41 on the digital PCB. When the test-probe lead is then connected to any video developmental signal, that signal will be coupled to the video signal going to the TV monitor and a video probe picture will appear on the TV screen. The shape and other characteristics of this picture will give information about the signal being probed. The video probe is suited for troubleshooting synchronization and image signals, but will not be useful for extremely fast signals (such as the clock) or for very slow analog or digital signals.

A video probe can be constructed in a few minutes from these common electrical components: a length of 20 AWG (American Wire Gauge) rubber-coated wire, a 4.7K-ohm, ¼-watt carbon resistor, and two test leads. For the leads, use a single Mouser test clip (Mouser #131C301 or 302) attached to one end of the wire, and a test prod containing the resistor on the other.

To assemble the video probe, proceed as follows: Remove the cap from the test clip and strip 3/16 inch off each end of the wire. Solder one end to the post in the test clip, thread the other end through the hole in the cap, and snap on the cap. Next unscrew the plastic body of the test prod from the point and trim both leads of the resistor to a 3/16-inch length. Solder one resistor lead to the inside of the point. Thread the other end of the wire through the hole in the body and solder it to the other resistor lead; screw the body back onto the point.

(b) *The Logic Probe.* This is a test instrument designed for fast verification of digital IC outputs. It is small, convenient to carry, easy to read, and relatively inexpensive. The logic probe derives its power from the system under test; it has two power leads, one for connection to ground and the other to +5 volts DC. When the logic probe's tip is held against a digital signal point, three colored lamps in the tip will indicate the signal's condition or state, as follows:

- The red lamp lit indicates a high or logic level 1 (for TTL components, this is +2.4 to +5 volts)
- The white lamp lit indicates a low or logic level 0 (for TTL components, this is 0 to +0.8 volt)
- The blue lamp lit indicates that the signal is changing states
- No lamps lit indicate the grey region between 0 and 1 (for TTL this is between +0.8 and +2.4 volts)

A circuit shorted to ground will illuminate the white lamp and an open circuit will illuminate the red lamp.

The logic probe is readily available from electronic supply sources; a commercial model found satisfactory is the Kurz-Kasch model LP 520.

(c) *The Logic Pulser.* This test instrument is similar in size and shape to the logic probe, and it also derives its power from the system under test. When the logic pulser's tip is held against a digital signal point, the source and sink capabilities of the pulser override any IC output and the point is driven to the opposite logic level. If the point that the logic pulser is held against is low, pressing the switch on the side of the pulser will introduce a high pulse. Conversely, pulsing a high line will pull that line low momentarily.

During troubleshooting the logic pulser allows stimulation of in-circuit ICs with a shaped digital pulse. For example, a certain feature of the game may not be working and you suspect that a circuit is not receiving the necessary signal. Use the pulser to imitate that signal: if the circuit begins working, you have proved that the signal was in fact missing and you can begin tracking it down. This technique is very similar to jumping coils in electromechanical games such as pinball machines.

In addition to the regular "pulse" button, there is another switch mounted on the logic pulser. When this switch is set in the "rep" mode, the instrument pulses the digital signal point at a 5-Hz rate or 5 times per second. This extremely low rate is slow enough to allow watching events initiated by the pulser. Counter outputs, for example, are more easily observed when the counter is pulsed or clocked at this rate.

The logic pulser is also readily available from electronic supply sources; a commercial model found satisfactory is the Kurz-Kasch model HL 583.

(d) *Oscilloscope.* The most versatile test instrument, and also the most expensive, is the oscilloscope. The high-speed TTL integrated circuits used in video games produce fast-rise-time signals. The oscilloscope should have a 50-MHz bandwidth, dual trace and dual time base capability. These latter features allow examination of both input and output signals simultaneously, so that precise timing relationships can be checked. The oscilloscope should also have provision for internal or external sync.

Of the newer, solid-state oscilloscopes, a satisfactory model is the Tektronix 465.

(e) *VOM or Volt-Ohmmeter.* This common measuring instrument is extremely useful in video

game troubleshooting. It can be used to check line voltage, transformer secondary windings, continuity, resistance, power supply voltages, and to some extent used for measurements in the analog circuitry.

One commercial model found satisfactory is the Simpson 260.

6.2.2 OPTIONAL TEST EQUIPMENT:

(a) *The Logic Comparator.* This test instrument's main benefit is that it can be used to check the functioning of an integrated circuit device while the device is still in place on the printed circuit board. The logic comparator performs the check by comparing the suspect ICs functioning with that of an identical-type reference IC mounted in the instrument itself. Suppose that the functioning of a type-74193 device on the PCB is suspected to be defective. First insert a program card with a known-to-be-good 74193 into the logic comparator, and then clip the comparator test leads onto the leads of the suspect device. If there are any logic state differences between the reference IC and the suspect IC under test, then an LED on the logic comparator will light up to indicate which output is not functioning correctly. Once a defective IC has been located, it should be replaced.

Logic comparators are readily available from electronic supply sources.

(b) *Atari Universal Test Fixture.* In situations where a large number of video games are being serviced, investment in the Universal Test Fixture will be justified. This item of test equipment forms a test station for troubleshooting printed circuit boards after they have been removed from the game cabinet. The Universal Test Fixture has a full set of controls for operating the game and also has its own TV monitor. The game's PCB is plugged into an edge connector mounted on the side of the Fixture; with this arrangement the PCB is positioned in a convenient way for connecting probes and other test instruments.

A program card inserted into a receptacle in the top of Fixture takes the place of the game's interconnect wires. The program card thus sets up the Fixture for each particular game; the game's name is clearly printed on the program card itself.

With the Universal Test Fixture the method of troubleshooting via substitution of known-to-be-good parts is made fast and convenient. For example, suppose that the TV picture in a game is completely broken up and you want to determine whether the game or monitor is causing the problem. Remove the PCB and plug it into the Fixture's edge connector, and also insert the correct program

card for that game. If the picture on the Fixture's monitor is correct, then you know that the problem lies in the game's monitor.

6.3 SPECIFIC TROUBLESHOOTING INFORMATION

The following subparagraphs give additional troubleshooting information about certain areas of the Cops 'N Robbers game.

6.3.1 COIN MECHANISM: If a player inserts a coin and the game does not respond, first check the coin mechanism. If pressing the coin rejector button forces the rejector mechanism to return the coin, then examine the coin to make sure that it is genuine. If it is, then use a set of your own test coins (which should include both very new and very old, worn coins) to determine whether or not the player's coin is undersize or underweight. If your test coins are also returned, this indicates that servicing of the coin acceptor portion of the coin mechanism is called for. Generally the cause of this particular problem is an improperly adjusted magnet gate.

Inside the coin mechanism a magnet is used to test the metallic composition of the coin. Highly magnetic coins, such as those made of steel or iron, will be retained by the magnet and can be returned by actuating the wiper operating lever. Coins having comparatively high magnetic properties will be slowed down by the magnet, and will drop off the end of the rail short of the "accept" entrance and be returned. Coins having little or no magnetic properties, such as brass or zinc coins, will pass through the magnetic field so fast that they will overshoot the "accept" entrance and be returned.

A magnetic gate adjusted with too large a gap may pass both genuine and counterfeit coins. An adjustment with too small a gap can lead to rejection of some or even all coins. Over a period of time, the screw that adjusts the magnet gate has a tendency to work loose, resulting in a gradual narrowing of the gate. At first, only the thickest (i.e., newest) coins are rejected. As time passes, more and more coins are rejected until finally player complaints lead to the calling of the game repairman.

If pressing the coin rejector button does not cause the coin to be returned, and if the game still does not respond, then check the coin mechanism to see if the coin is jammed inside.

If you are certain that the coin is genuine, and that the coin passes through the coin mechanism and into the cash box, then the lack of game response is probably due to some kind of electrical trouble. Check for signals at the electrical contacts

of the coin mechanism before moving on to the harness and other parts of the circuitry.

6.3.2 TV MONITOR: The TV monitor is a self-contained unit housed in its own chassis. A trouble's cause may be narrowed down to the monitor—either by the substitution method using a known-to-be-good monitor, or by verifying presence of AC power to the monitor power supply and presence of the correct composite video signal. The entire monitor can then be removed from the game cabinet. Doing this facilitates troubleshooting steps, because all monitor components will then be accessible.

A schematic diagram of the monitor circuitry is included in Section VII of this manual. After disconnecting and removing the monitor from the game, standard TV troubleshooting techniques are adequate for locating causes of trouble. Additional servicing information is available from the monitor manufacturer (Motorola).

6.3.3 ANTENNA STATIC MODIFICATION: This subparagraph gives a procedure for modifying the antenna wire connected to pin 7 of the digital printed circuit board's edge connector. The antenna is part of the credit portion of the game circuitry. This static modification feature is included so that it will not be possible for a player to obtain bonus games (that is, game plays without having deposited money into the game) by inducing a static charge in the coin entrance plate or any other metal part of the game—provided that the antenna has been cut to optimum length.

The antenna is a wire approximately one foot long, with one end intentionally left not connected. When a static discharge occurs, an electric current is induced in this wire and an impulse is transmitted to the credit circuitry on the digital PCB. This impulse resets the circuitry, turning off game credit and changing the game over to the attract mode. To test the static modification feature, touch the end of the antenna wire with your finger; the body usually has enough capacitance to trigger the circuitry. Sensitivity of the static modification feature can be adjusted by changing the length of the antenna wire. Lengthening the wire increases sensitivity, so that a lesser charge will turn off game credit. Cutting the wire shorter decreases sensitivity, so that a larger charge is required for triggering the circuit.

If there are problems with static charges accidentally shutting off the game credit, try cutting the wire shorter, in increments of 1/2 inch at a time. Be aware, however, that if the antenna wire is cut too short, players may be able to obtain free game credit (bonus games) by inducing a static charge in the game.

VII. SCHEMATICS, DRAWINGS, AND PARTS LISTS

<i>Number</i>	<i>Title</i>
A005590	Parts List and Drawing Final Cabinet Assembly
A005726	Parts List and Drawing Decal Location Diagram
A005604	Parts List and Drawing Control Panel Assembly
A005677	Parts List and Drawing Gun Control Assembly
A005603	Parts List and Drawing Foot Pedal Assembly
005718	Schematic Harness
A005600	Parts List and Drawing Electronics Tray Assembly
A005625	Schematic, Parts List and Assembly Digital Printed Circuit Board
A005627	Schematic, Parts List and Assembly Audio & Switch Matrix PCB
(none)	Schematic Motorola XM501/701 Monitor



ASSEMBLY TITLE / FINAL ASSEMBLY

P/L A005590

PARTS LIST SPECIFICATION

Page 1 of 1

Drawn			
Checked	<i>5/24/76</i>	Mech. Eng.	
Proj. Eng.	<i>5/24/76</i>	Elec. Eng.	REV. B

Rev.	Description	Date	Apprv.	Rev.	Description	Date	Apprv.
A	PROD REF.	5-24-76					
B	Rev per ECN 2672	6-8-76					

Item	Part Number	Qty.	DESCRIPTION
1	A005561-02	1	Cabinet Assy, w/Silkscreen Graphics
2	A005604	1	Control Panel Assy
3	A005605	1	T.V. Enclosure, End Cap Assy
4	A005607	1	Rear Door Assy
5	A005603	1	Foot Pedal Assy
6	A003637-11	1	Coin Door Assy
7	A004286-10	1	R.F. Shielding Box Assy
8	A005600	1	Electronics Tray Assy
9	005419	2	Speaker Mesh Cover
10	73-77004	8	Rivets, 3/16 x .68 Lg
11	005595	1	Mirror Panel
12	005599	1	Alum. Plex Retainer
13	005578	1	Alum. Mirror Retainer
14	005594	4	Monitor Tie Down Brkts
15	72-6812	25	Screws, Self-Tapping, #8 x 3/4 Phil Pan Hd
16	92-007	1	23" T.V. Monitor (XM701-10)
17	005598	1	Smoked Plexiglas
18	48-001	2	Speaker, 8"
19	72-6824	16	Screws, S.T. #8 x 1 1/2 Phil Pan Hd
20	005597	REF	Monitor Plexiglas Panel
21	005723	1	Monitor Plex Panel w/Graphics
22	005596	REF	Main Front Plex Panel
23	005724	1	Main Front Plex Panel w/Graphics
24	82-8516	9	Screw, Mach Truss Hd, Hex Drive, 1/2-20 x 1 Lg
25	68-001	1	Interlock Switch
26	000268-01	1	Switch Mounting Bracket
27	72-6612	11	Screw, S.T. #6x3/4 Phil Pan Hd.
28			
29	82-8116	3	Screw, Mach Truss Hd, Hex Drive, #10-24 x 1" Lg
30	75-5124B	6	Carriage Bolts, 10-24 x 1 1/2 Lg
31	75-0108	6	Flat Washer, #10
32	75-911S	6	Hex Nuts, #10-24
33	75-040	6	Lock Washers, #10
34	A005627	1	Audio P.C. Board Assembly
35	005719-XX	1	Shipping Container
36	005233	1	Rear Door Seal
37	005725	1	ABS Protective Shield
38	005726	1	Decal Location Assembly
39	72-6832	4	Screws, S.T. #8 x 2 Phil Pan Hd
40	A005602	1	Main Harness Assembly
41	TM-059	1	Technical Manual

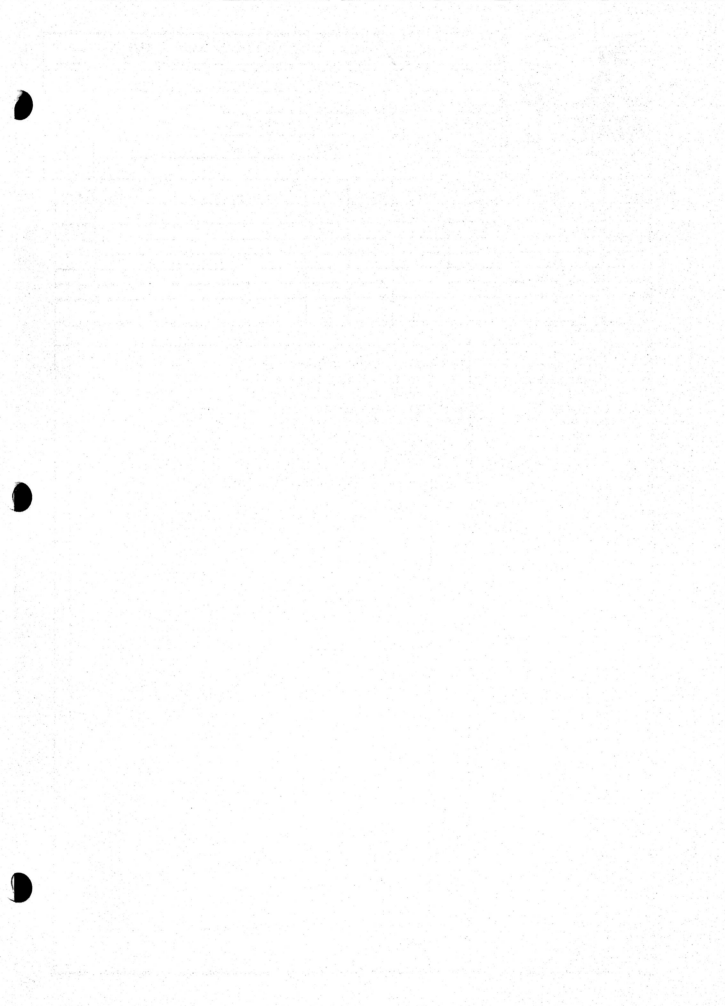



PARTS LIST SPECIFICATION

Page 1 of 1

Drawn _____

Checked _____

Proj. Eng. _____

Mech. Eng. _____

5/16/76 Elec. Eng. _____

REV.

A

Rev.	Description	Date	Apprv.	Rev.	Description	Date	Apprv.
A	PROD REL	5/26/76					

Item	Part Number	Qty.	DESCRIPTION
1	005823-01	2	Blue, Decal Color Strip
2	005823-02	3	Yellow, Decal Color Strip
3	005823-03	2	Amber, Decal Color Strip
4	92-007	Ref	23" T.V. Monitor

NOTICE TO ALL PERSONS RECEIVING THIS DRAWING: THIS DRAWING IS THE PROPERTY OF AT&T BELL LABORATORIES. IT IS TO BE USED ONLY FOR THE PROJECT AND PURPOSE SPECIFIED HEREON. IT IS NOT TO BE REPRODUCED, COPIED, OR TRANSMITTED IN ANY FORM OR BY ANY MEANS, ELECTRONIC OR MECHANICAL, INCLUDING PHOTOCOPYING, RECORDING, OR BY ANY INFORMATION STORAGE AND RETRIEVAL SYSTEM, WITHOUT THE WRITTEN PERMISSION OF AT&T BELL LABORATORIES. THIS DRAWING IS NOT TO BE USED FOR ANY OTHER PROJECT OR PURPOSE WITHOUT THE WRITTEN PERMISSION OF AT&T BELL LABORATORIES. THIS DRAWING IS NOT TO BE USED FOR ANY OTHER PROJECT OR PURPOSE WITHOUT THE WRITTEN PERMISSION OF AT&T BELL LABORATORIES.

4 3 2 1

ZONE	TIME	DESCRIPTION	DATE	APPROVED
A		PROD. REL	5-28-76	

DRAWING NO	SHEET	REV

D C B

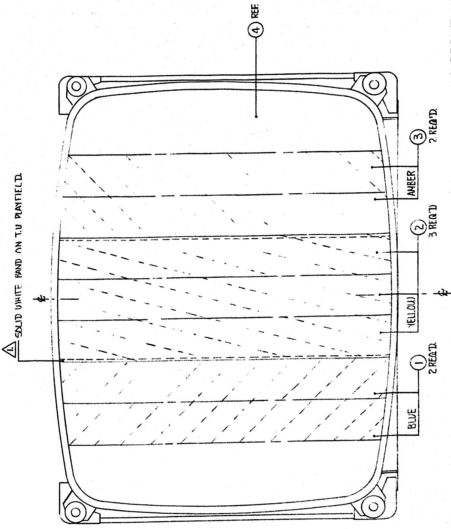

NOTES:

THE PLAYFIELD IS TO BE ADJUSTED SMALLER SO THAT THE T.U.D. AND WHITE LINES ARE JUST COVERED BY THE YELLOW STRIPS.

OUTSTANDING ECG:	

CURRENT VERSION -01

CHECKED BY:
 DRAWING ENGINEER:
 DRAWING DESIGNER:
 DRAWING CHECKER:
 DRAWING APPROVER:
 DATE: 5-28-76

AT&T INCORPORATED
 1400 WASHINGTON BLDG
 101 CUNY, TOWSON MD 21286



ASSEMBLY TITLE / ASSEMBLY, CONTROL PANEL P/L A005604

PARTS LIST SPECIFICATION

Page 1 of 1

Drawn

Checked

5/27/76

Mech. Eng.

Proj. Eng.

9/24/76

Elec. Eng.

REV.
B

Rev.	Description	Date	Apprv.	Rev.	Description	Date	Apprv.
A		5-24-74					
B	Rev per ECN 2694	6-15-76					

Item	Part Number	Qty.	DESCRIPTION
1	005609	1	Control Panel w/Graphics
2	A005677	4	Final Assy, Gun Control
3	75-5512N	16	Carriage Bolts, # $\frac{1}{4}$ -20 x 3/4 Lg
4	75-045	16	Lock Washer, # $\frac{1}{4}$
5	75-945S	16	Hex Nut, # $\frac{1}{4}$ -20, Self-Locking
6	A004304-07	1	Switch Assy, One Player Start
7	A004304-13	1	Switch Assy, Multi Player Start
8	005576	Ref	Alum Control Panel
9	A005606	1	Control Panel Harness Assembly

8
 7
 6
 5
 4
 3
 2
 1

D
 C
 B
 A

8
 7
 6
 5
 4
 3
 2
 1

D

C

B

A

8

7

6

5

4

3

2

1

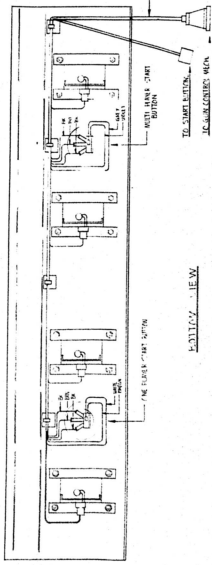
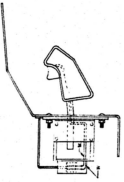

FIGURE 1 - VIEW



NOTE:
 MORE DETAIL IS ONLY AN ILLUSTRATION
 FOR CLARITY IN SOME COLOR OF THE START
 BUTTONS.

CURRENT VERSION - 01

ATARI 1000 WEST GARDEN AVENUE BERKELEY, CALIF. 94704 (415) 841-5800	CONTROL PANEL ASSY PART NO. A00560.04
DATE: 12/11/77 BY: J. J. [unclear]	REV: 1

8
 7
 6
 5
 4
 3
 2
 1

D

C

B

A

8
 7
 6
 5
 4
 3
 2
 1

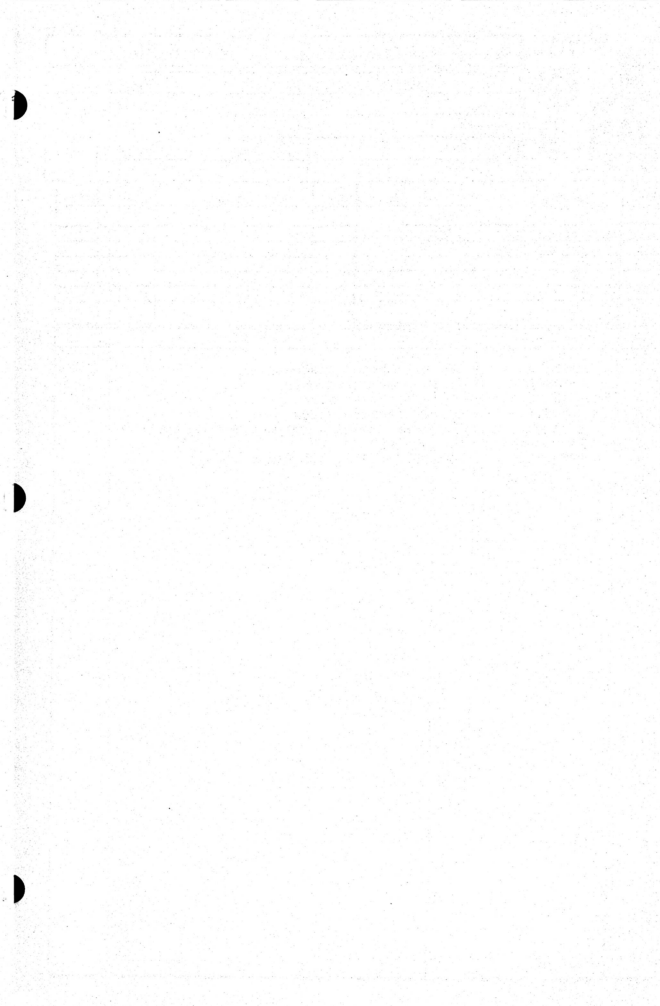

ASSEMBLY TITLE / GUN CONTROL FINAL ASSEMBLY P/L A005677



PARTS LIST SPECIFICATION

Page 1 of 1

Drawn		
Checked	Mech. Eng.	
Proj. Eng.	Elec. Eng.	REV. C

Rev.	Description	Date	Apprv.	Rev.	Description	Date	Apprv.
A		5/27/76					
B	Rev per ECN 2682	6/9/76					
C	Rev per ECN 2687	6/10/76					

Item	Part Number	Qty.	DESCRIPTION
1	A005675	1	Main Frame Assembly
2	A005676	1	Gun Grip Assembly
3	A005416	1	Wiper Assembly
4	005674	1	Protective Slide
5	72-E124C	1	Screw Shouldered, Allen Socket 10-24 x 1 1/4 Lg.
6	78-3001014	1	Spring
7	73-0212	1	Cotter Pin, 1/8 Dia x 3/4 Lg

THIS DRAWING IS THE PROPERTY OF AT&T
 TELEPHONE LABORATORIES, INC. IT IS TO BE
 KEPT IN CONFIDENCE AND IS NOT TO BE
 REPRODUCED OR TRANSMITTED IN ANY
 FORM OR BY ANY MEANS, ELECTRONIC
 OR MECHANICAL, INCLUDING PHOTOCOPYING,
 RECORDING, OR BY ANY INFORMATION
 STORAGE AND RETRIEVAL SYSTEM, WITHOUT
 THE WRITTEN PERMISSION OF AT&T
 TELEPHONE LABORATORIES, INC.

REV.	DATE	DESCRIPTION
1		RELEASE FOR PROCD.
A		REEL REV. E.C.N. # 34-837
B		REV. PER E.C.N. # 34-837
C		REV. PER E.C.N. # 34-837

REV. PER E.C.N. # 34-837
 1
 C

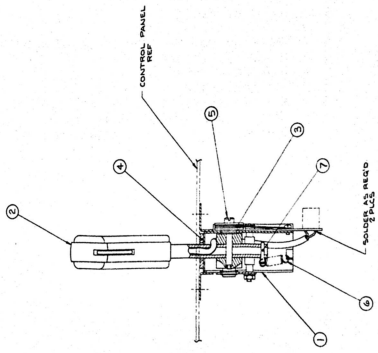
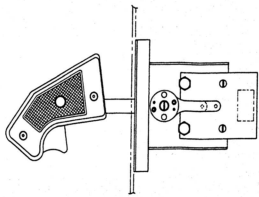

AT&T
 TELEPHONE LABORATORIES, INC.
 7/76
 SEE PARTS LIST
 ADD'G 677
 REV. PER E.C.N. # 34-837
 1
 C

NOTES: UNLESS OTHERWISE SPECIFIED



PARTS LIST SPECIFICATION

Page 1 of 1

Drawn

Checked

5/24/76

Mech. Eng.

Proj. Eng.

5/24/76

Elec. Eng.

REV.

A

Rev.	Description	Date	Apprv.	Rev.	Description	Date	Apprv.
A		5/24/76					

Item	Part Number	Qty.	DESCRIPTION
1	005580	Ref	Mounting Board Foot Pedals
2	A003511	4	Single Foot Pedal Assy
3	005587	1	Rear Mntg Bracket
4	005586	1	Front Mntg. Bracket
5	72-6812	14	Screws, S.T. #8 x 3/4 Phil Pan Hd
6	75-018S	16	Flat Washer #8
7	75-048	16	Lock Washer #8
8	002191	4	Brkt. Switch
9	72-1416S	8	Mach Screw, #4-40 x 1" Lg, Pan Hd Phil
10	75-044	8	Lock Washer, #4
11	75-914S	8	Hex Nut, #4-40
12	65-071C	4	Switch, Cherry
13	75-918S	16	Hex Nuts, #8-32
14	A005608	1	Foot Pedal Harness Assy
15	72-6612	4	Screws, S.T. #6 x 3/4 Phil Pan Hd

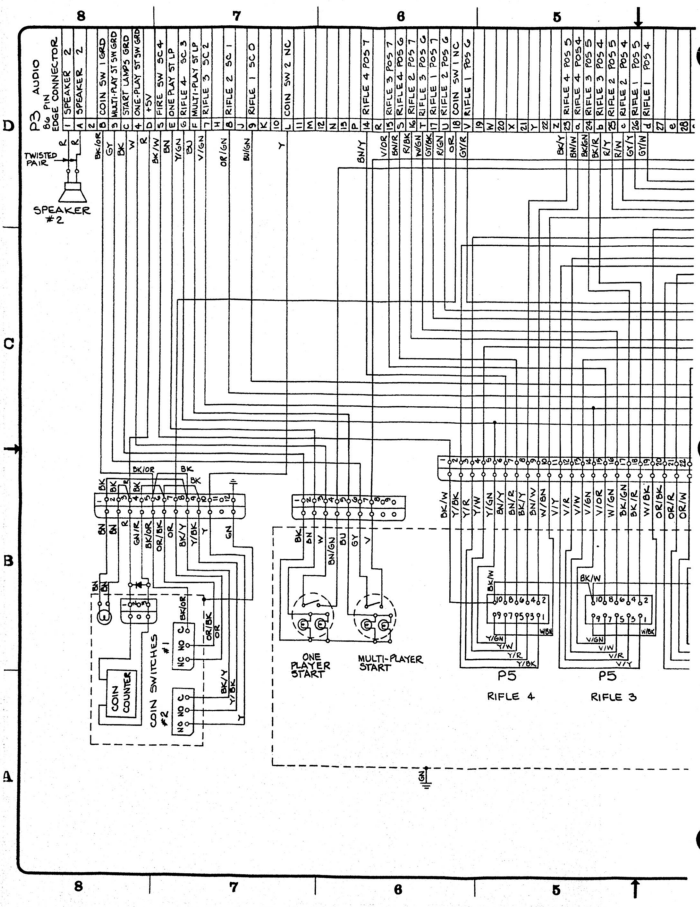

COIN COUNTER

COIN SWITCHES
#1
#2

ONE
PLAYER
START

MULTI-PLAYER
START

P5
RIFLE 4

P5
RIFLE 3

P3 AUDIO
9-PIN
EDGE CONNECTOR
SPEAKER 2

D

C

B

A

8

7

6

5

8

7

6

5

4 3 2 1

REVISIONS			
ITEM	DESCRIPTION	INITIALS AND DATE	
SEE SHEET 1			

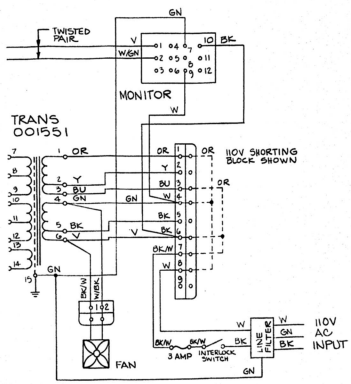

D
C
B
A

ATARI INC
000718
5/82
A

CURRENT VERSION -01

NOTE TO ALL PERSONS REVIEWING THIS DRAWING
CONFIDENTIAL. Reproduction forbidden without the
written consent of Atari Inc. This drawing
is the property of Atari Inc. and is to be
used only for the specific project for which it was
prepared. It is to be destroyed when the project
is completed. It is to be kept in a secure place
and not to be loaned, given, or otherwise
distributed to any person outside the project
without the express written permission of Atari Inc.

NO.	DATE	DESCRIPTION

INTERPRET THIS DRAWING PER CEAS 1147	DRAWN BY DATE 5-1978	<p>ATARI INCORPORATED 1440 Wilshire Boulevard Los Angeles, California 90017</p>
UNLESS OTHERWISE SPECIFIED DIMENSIONS ARE IN INCHES TOLERANCES ON	CHECKED DESIGN ENGINEER PROJECT ENGINEER DRAWING CONTROL	
FRACTIONS - 1/16 1/8 1/4 DECIMALS - 0.01 0.05 0.1 SURFACE FINISH - 125 250 500	APPROVED TITLE COPS & ROBBERS HARNESS SCHEMATIC	SHEET 2 OF 2
MATERIAL	NEXT ADD USED ON APPLICATION	DRAWING NO. 000718 DATE 5/82

4 3 2 1

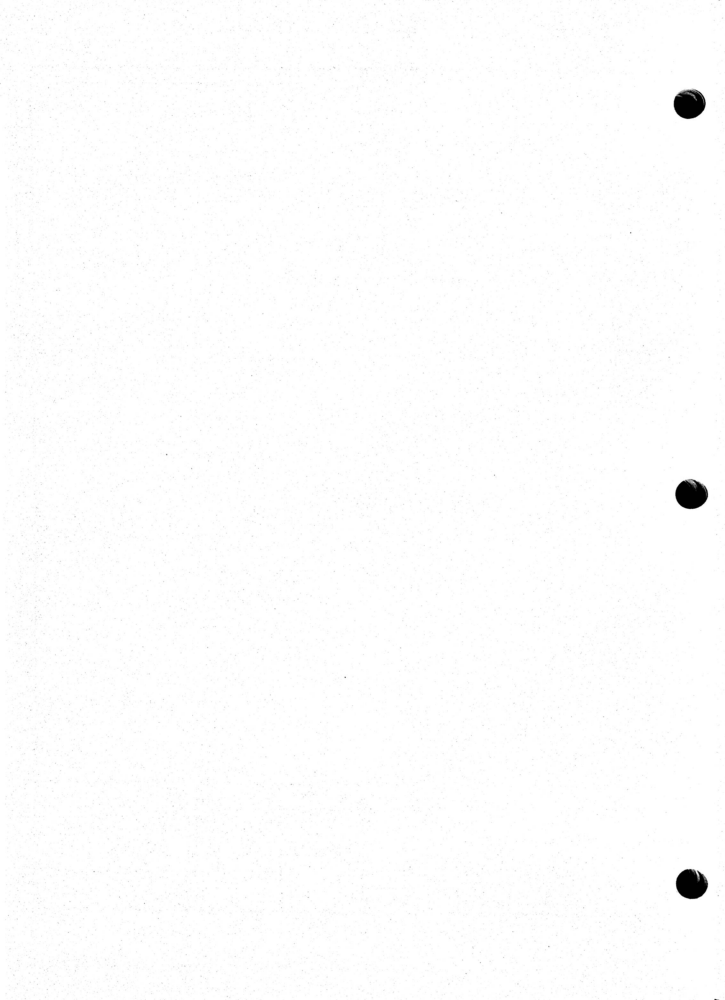



ASSEMBLY TITLE / ELECTRONICS TRAY ASSEMBLY

P/L A005600-01

PARTS LIST SPECIFICATION

Page 1 of 1

Drawn	
Checked	Mech. Eng.
Proj. Eng.	Elec. Eng.
	REV. A

Rev.	Description	Date	Apprvd	Rev.	Description	Date	Apprv.
A	PROD REL	4-15-72					

Item	Part Number	Qty.	DESCRIPTION
1	005601-01	1	Electronics Tray
2	A005727-01	1	Harness, Power Supply
3	A004381-01	1	AC Power Cord, 8 Ft Assy
4	41-2001	1	Filter, 2 amp Power Line
5	46-202301	1	Fuse, 3 amp
6	79-3201	1	Fuse Holder
7	000622-01	1	Cover AC Power
8	000871-01	1	Label
9	001551-01	1	Transformer, 001551
10	A001921-01	A/R	Shorting Block, 95V
11	A001921-02	A/R	Shorting Block, 110V
12	A001921-03	A/R	Shorting Block, 220V H
13	A001921-04	A/R	Shorting Block, 220V L
14	72-6608	2	Screw, SM, Pan Hd Phil, #6 x 1/4 Lg
15	72-6612	6	Screw, SM, Pan Hd Phil, #6 x 3/4 Lg
16	72-6812	8	Screw, SM, Pan Hd Phil, #8 x 3/4 Lg

4

3



NOTICE TO ALL PERSONS RECEIVING THIS DRAWING
 CONFIDENTIAL: Reproduction forbidden without the specific written permission of Axiel Inc., Los Altos, California. This drawing is only conditionally loaned and neither storage nor possession thereof creates or transmits any right to, or license to use, the subject matter of the drawing or any design or technical information shown therein, nor any right to reproduce this drawing or any part thereof, except for manufacture by contract for Axiel Incorporated and for maintenance under the corporation's written license, no right to reproduce this drawing is granted or the subject matter loaned herein by written agreement with or written permission from the corporation.

D

C

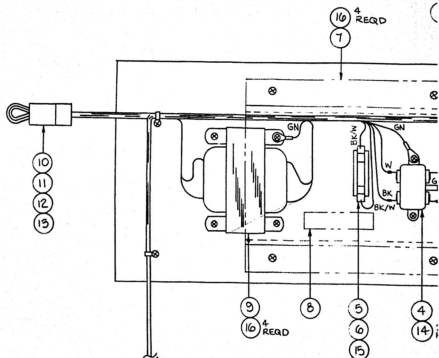

B

TRANSFORMER WIRING		
PIN NO	COLOR	SOURCE
1	OR	POWER SUPPLY HARNESS
2	Y	
3	BU	
4	GN/BWBK	
5	BK	
6	V/B BK/W	
7	W	
8	GN/W	
9	W	
10	Y	
11	GN/Y	
12	Y	
13	—	
14	—	
15	GN	

A

DC BK/W
 N.O.
 TO INTERLOCK SW
 TO FAN

NOTES : UNLESS OTHERWISE SPECIFIED

NEXT ASSY	USED ON
APPLICATION	

4

3



8

7

6

5

INVEST TO ALL PERSONS RECEIVING THIS DRAWING
 THE DRAWING IS THE PROPERTY OF THE DRAWING ENGINEER
 AND IS NOT TO BE REPRODUCED OR TRANSMITTED IN ANY FORM OR BY ANY MEANS
 WITHOUT THE WRITTEN PERMISSION OF THE DRAWING ENGINEER. THE DRAWING ENGINEER
 ACCEPTS NO LIABILITY FOR ANY DAMAGE OR LOSS OF PROFITS OR BUSINESS
 ARISING FROM THE USE OF THIS DRAWING. THE DRAWING ENGINEER IS NOT
 RESPONSIBLE FOR ANY DAMAGE OR LOSS OF PROFITS OR BUSINESS ARISING FROM
 THE USE OF THIS DRAWING. THE DRAWING ENGINEER IS NOT RESPONSIBLE FOR
 ANY DAMAGE OR LOSS OF PROFITS OR BUSINESS ARISING FROM THE USE OF
 THIS DRAWING. THE DRAWING ENGINEER IS NOT RESPONSIBLE FOR ANY DAMAGE
 OR LOSS OF PROFITS OR BUSINESS ARISING FROM THE USE OF THIS DRAWING.

D

C

B

A

NOTES - UNLESS OTHERWISE SPECIFIED

8

7

6

5

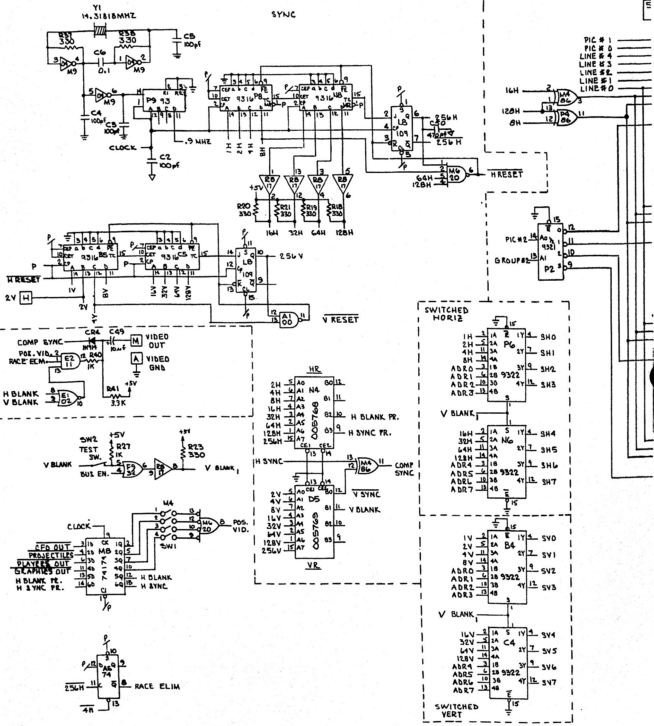

4

3

2

1

512 x 8 PROMS

GROUP 0, PIC 0-3

PLAYER WINDOWS

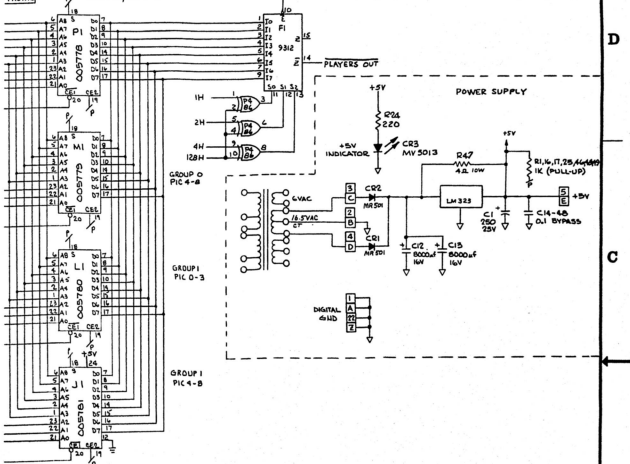

NOTICE TO ALL PERSONS RECEIVING THIS DRAWING: CONFIDENTIAL. Reproduction, distribution, or use of this drawing without the written consent of Atari, Inc. is strictly prohibited. The drawing is not to be used for any other purpose without the written consent of Atari, Inc. This drawing is the property of Atari, Inc. and is loaned to you for your use only. It is not to be distributed, copied, or otherwise used in any way without the written consent of Atari, Inc. This drawing is the property of Atari, Inc. and is loaned to you for your use only. It is not to be distributed, copied, or otherwise used in any way without the written consent of Atari, Inc.

DATE	3-12-76
DESIGNED BY	
CHECKED BY	
PROJECT ENGINEER	
DOCUMENT CONTROL	
APPROVED	
DATE	
USED ON	
APPLICATION	

INTERPRET THIS DRAWING FOR YOUR USE	DATE	3-12-76
UNLESS OTHERWISE SPECIFIED DIMENSIONS ARE IN INCHES TOLERANCES ON	DATE	
FRACTIONS: +.010 -0.005	DESIGNED BY	
ANGLES: ±0.1°	CHECKED BY	
SURFACE FINISH: ✓	PROJECT ENGINEER	
MATERIAL	DOCUMENT CONTROL	
	APPROVED	
	DATE	
	USED ON	
	APPLICATION	



ATARI INCORPORATED
1400 Webster Avenue
Los Gatos, California 95032

TITLE SCHEMATIC
COPS & ROBBERS
DIGITAL P.C. BD.

SIZE D DRAWING NO. 005625 REV. A
SHEET 2 OF 3

4

3

2

1

B

C

D

A

DATE

SCALE

REV. NUMBER

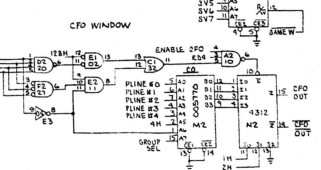
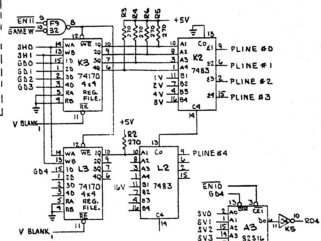
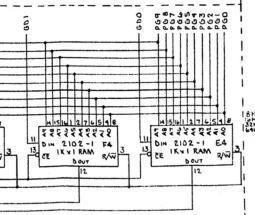
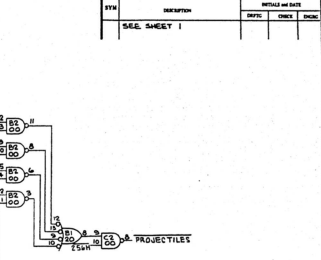
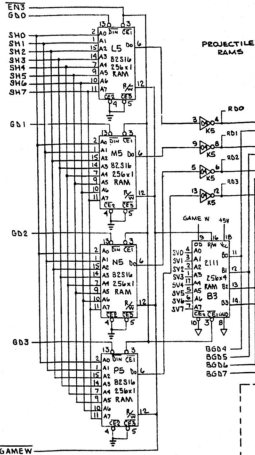

REVISED			
REV	DESCRIPTION	INITIALS AND DATE	
1	SEE SHEET 1		

APHICS OUT

NOTICE TO ALL PERSONS RECEIVING THIS DRAWING: This drawing is the property of Atari Inc. and is loaned to you for your information only. It is not to be reproduced, copied, or distributed in any form without the written consent of Atari Inc. The drawing is to be used for the purpose specified and is not to be used for any other purpose. The drawing is to be returned to Atari Inc. when it is no longer needed. The drawing is to be kept in a safe place and is to be protected from fire and theft. The drawing is to be kept in a safe place and is to be protected from fire and theft.

DATE	BY
3-10-79	F. S. STON
DATE	BY
DATE	BY
DATE	BY

INTERFILE THIS DRAWING PER LEAD 714	DRAWN BY F. S. STON	DATE 3-10-79
DESIGN CHECKED BY P. S. STON	DESIGNED BY P. S. STON	PROJECT ENGINEER P. S. STON
FRACTIONAL - 1/16 1/8 1/4 3/8 1/2 5/8 3/4 7/8	UNLESS NOTED OTHERWISE	STANDARD FINISH
MATERIAL	DOCUMENT CONTROL	APPROVED
DATE	BY	DATE

ATARI ATARI INCORPORATED
1402 Woodside Boulevard
Los Gatos, California 95030

TITLE: **COPS & ROBBERS DIGITAL PC. 80**

REV: **D** DRAWING NO: **005625** REV: **A**

DATE: **3-10-79**



PARTS LIST SPECIFICATION

Page 1 of 3

Drawn

Checked

Proj. Eng.

Mech. Eng.

Elec. Eng.

REV.

A

Rev.	Description	Date	Apprv.	Rev.	Description	Date	Apprv.
A	PROD REL	5/26/76					

Item	Part Number	Qty.	DESCRIPTION	
1	005626-01	1	PRINTED CIRCUIT BOARD	
2	10-5102	8	Res, Car, Comp $\frac{1}{2}$ w 5% 1K OHM	R1, 16, 17, 25-27, 40, 46, 4B,
3	10-5153	1	" " " " " 15K OHM	R45 ⁴⁹
4	10-5221	1	" " " " " 220 OHM	R24
5	10-5271	22	" " " " " 270 OHM	R2-15, 29-36
6	10-5331	8	" " " " " 330 OHM	R18-23, 37, 38
7	10-5332	2	" " " " " 3.3K OHM	R28, 41
8	10-5333	1	" " " " " 33K OHM	R44
9	10-5471	1	" " " " " 470K OHM	R43
10	10-5473	1	" " " " " 47K OHM	R39
11	10-5474	1	" " " " " 470K OHM	R42
12	19-808W4P0	1	Res, Wirewound 10w 20% 4 OHM	R47
13				
14				
15	24-250106	3	Cap, Elect. 10uf 25V	C8, 9, 49
16	24-250227	1	" " 220uf 25V	C1
17	24-160808	2	" " 8000uf 16V	C12, 13
18	27-250103	2	" Cer. Disc .01 25V	C7, 10
19	27-250104	37	" " " 0.1 25V	C6, 11, 14-48
20	28-101101	4	" Dipped Mica 100pf 100V	C2-5
21	28-101471	1	" " " 470pf 100V	C50
22				
23	31-IN914	3	Diode, IN914	CR4-6
24	31-MR501	2	Rectifier, MR501	CR1, 2
25	38-MV5013	1	LED, MV5013 (RED)	CR3
26				
27	33-2N3644	1	Transistor 2N3644	Q2

PARTS LIST SPECIFICATION

REV A

Page 2 of 3

Item	Part Number	Qty.	DESCRIPTION
28	34-2N3643	1	Transistor 2N3643 Q1
29			
30	37-7400	3	I.C. 7400 A1, B2, C2
31	37-7402	1	" 7402 E1
32	37-7404	3	" 7404 E3,K5,M9
33	37-7408	7	" 7408 D1,D8,E8,F8,H9,J9,L9
34	37-7410	2	" 7410 A2,D3
35	37-7411	1	" 7411 E2
36	37-7417	1	" 7417 R8
37	37-7420	3	" 7420 B1,D2,M6
38	37-7427	1	" 7427 F2
39	37-7432	3	" 7432 C1,F9,K9
40	37-7474	1	" 7474 A5
41	37-7483	4	" 7483 J2,H2,K2,L2
42	37-7486	2	" 7486 M4,P4
43	37-7493	1	" 7493 P9
44	37-74109	1	" 74109 L8
45	37-74170	5	" 74170 F3,H3,J3,K3,L3
46	37-74174	1	" 74174 M8
47	37-9312	3	" 9312 F1,N2,P3
48	37-9316	4	" 9316 B5,C5,N8,P8
49	37-9321	1	" 9321 P2
50	37-9322	7	" 9322 B4,C4,E5,F5,L6,N6,P6
51	37-8T28	4	" 8T28 A4,D4,H5,J5
52	37-LM323	1	Regulator LM323
53			
54	90-7008	5	RAM 82S16 A3,L5,M5,N5,P5
55	90-7014	6	" 2102-A E4,F4,H4,J4,K4,L4
56	90-7015	4	" 2111-A B3,C3,N7,P7
57			
58	005765-01	1	PROM, μ p ENABLE (82S123) H8
59	005766-01	1	" ENABLE A " K8
60	005767-01	1	" ENABLE B " J8
61	005768-01	1	" HORIZONTAL (82S129) N4
62	005769-01	1	" VERTICAL " D5
63	005770-01	1	" CENTER FIELD OBJECT (82S129) M2
64	005771-01	1	" PROGRAM 7 (82S115) B7

Item	Part Number	Qty.	DESCRIPTION
65	005772-01	1	PROM, PROGRAM 6 (82S115) D7
66	005773-01	1	" " 5 " E7
67	005774-01	1	" " 4 " H7
68	005775-01	1	" " 3 " J7
69	005776-01	1	" " 2 " K7
70	005777-01	1	" " 1 " L7
71	005778-01	1	" PLAYER 1 " P1
72	005779-01	1	" " 2 " M1
73	005780-01	1	" " 3 " L1
74	005781-01	1	" " 4 " J1
75	005782-01	1	" ALPHA-NUMERICS (82S115) M3
76			
77	90-6005	1	INTEGRATED CIRCUIT B9
78	90-6009	1	" " B8
79	62-001	1	Switch, Mom, SPST N.O. SW3
80	69-004	1	Switch, SPDT SW2
81	66-114PIT	1	Switch, DIP, 4xSPST SW1
82	90-101	1	CRYSTAL, 14.31818 MHZ Y1
83			
84	78-06001	1	HEATSINK
85	78-16005	1	SILPAD
86	72-1608C	2	Screw, Mach, Pan Hd, Phil, #6-32 x $\frac{1}{2}$ CRES
87	75-016	2	Washer, Flat, #6
88	75-056	2	Washer, Lock, Internal Star #6
89	75-916C	2	Nut, Hex, Mach, #6-32 CRES
90			
91	79-42516	5	Socket, Zero Insertion Force, 16 Pin M2,M4, ,D5, H8,J8,K8
92	79-42524	12	" " " " 24 Pin J1,M1,L1,P1, M3,B7,D7,E7,H7,J7, K7,L7
93	79-42540	2	" " " " 40 Pin B8,B9

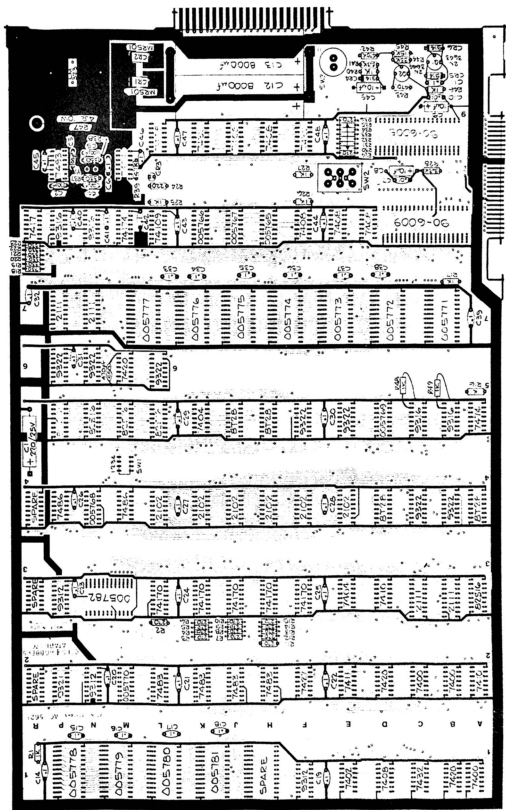

CURRENT VERSION -01

AIRTEL ASSEMBLY, LOPO & ROBBERS BD UNITAL P C BD	
PART NO. A005625	REV. 1
D	A

NOTES:

1. SEE THIS ASSEMBLY WITH CURRENT VERSIONS A, B, C, D, E, F, G, H, I, J, K, L, M, N, O, P, Q, R, S, T, U, V, W, X, Y, Z.
2. SEE THIS ASSEMBLY WITH CURRENT VERSIONS A, B, C, D, E, F, G, H, I, J, K, L, M, N, O, P, Q, R, S, T, U, V, W, X, Y, Z.
3. ORIGINAL PARTS SHOULD BE USED IN THIS ASSEMBLY.
4. IN CALL-OUTS, THE LOCATION OF THE PART IS INDICATED BY THE LETTERS AND NUMBERS.

FIELD INSTRUCTIONS:

1. SEE THIS ASSEMBLY WITH CURRENT VERSIONS A, B, C, D, E, F, G, H, I, J, K, L, M, N, O, P, Q, R, S, T, U, V, W, X, Y, Z.

2. SEE THIS ASSEMBLY WITH CURRENT VERSIONS A, B, C, D, E, F, G, H, I, J, K, L, M, N, O, P, Q, R, S, T, U, V, W, X, Y, Z.

D

C

B

A

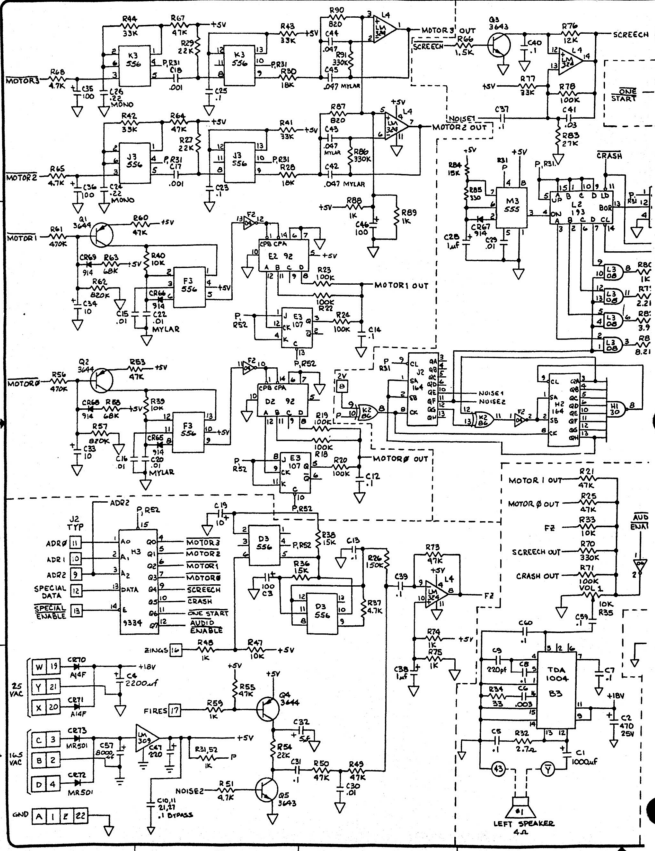

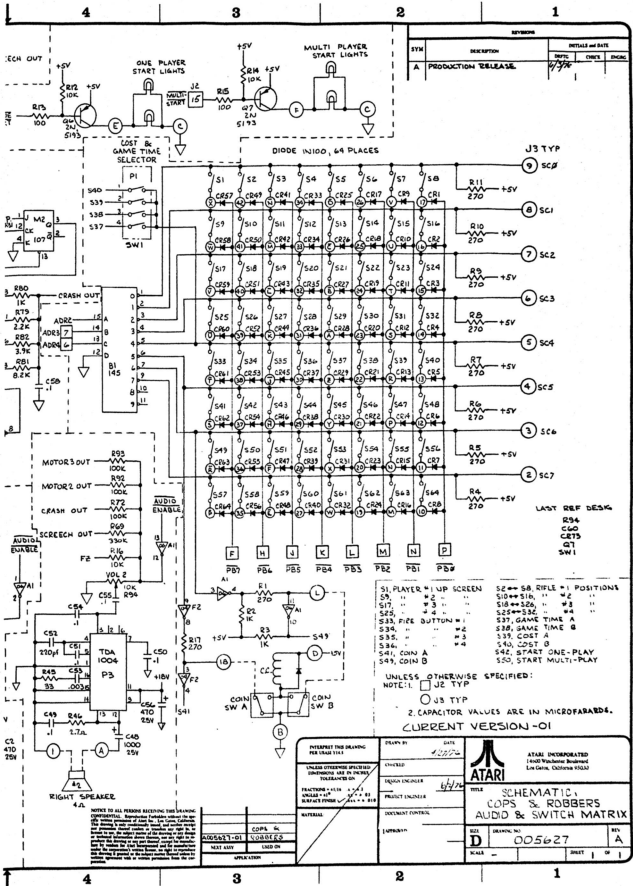

SYM	DESCRIPTION	INITIALS AND DATE		
		DATE	DESIGN	ENGR.
A	PRODUCTION RELEASE	4/7/76		

- S1, PLAYER #1 UP SCREEN
- S2 -- SA RIFLE #1 POSITIONS
- S10 -- S10, " #2 "
- S17 -- " #3 "
- S18 -- S20, " #3 "
- S25 -- " #4 "
- S26 -- S28, " #4 "
- S33, FIRE BUTTON = #1
- S34, " #2
- S35, " #3
- S36 -- " #4
- S41, COIN A
- S49, COIN B
- S52 -- SA RIFLE #1 POSITIONS
- S10 -- S10, " #2 "
- S18 -- S20, " #3 "
- S26 -- S28, " #4 "
- S37, GAME TIME A
- S38, GAME TIME B
- S39, COST A
- S40, COST B
- S42, START ONE-PLAY
- S50, START MULTI-PLAY

UNLESS OTHERWISE SPECIFIED:
 NOTE: 1. J2 TYPE
 2. CAPACITOR VALUES ARE IN MICROFARADS.
CURRENT VERSION - 01

PREPARED FOR DRAWING PER 10441 1111	DRAWN BY DATE CHECKED REGION ENGINEER PROJECT ENGINEER	ATARI INCORPORATED 1400 Winchester Boulevard Los Gatos, California 95030
UNLESS OTHERWISE SPECIFIED DIMENSIONS ARE IN INCHES TOLERANCES ARE:	TITLE SCHEMATIC OF COPS & ROBBERS AUDIO & SWITCH MATRIX	SHEET NO. 005627 REV. A
FRACTIONS -- 1/16, 1/8, 1/4, 1/2, 3/4 DECIMALS -- .1, .2, .3, .4, .5, .6, .7, .8, .9	MATERIALS	DOCUMENT CONTROL
APPROVED BY: CDP/A DATE: 4/10/76	NEXT ACTION: USED IN	SCALE: 1" = 1"

NOTICE TO ALL PERSONS RECEIVING THIS DRAWING
 CONFIDENTIAL: This drawing contains information which is the property of Atari, Inc. and is to be used only for the purposes intended. It is to be kept confidential and not to be distributed outside of Atari, Inc. without the express written permission of Atari, Inc. This drawing is to be returned to Atari, Inc. upon completion of the project for which it was prepared.

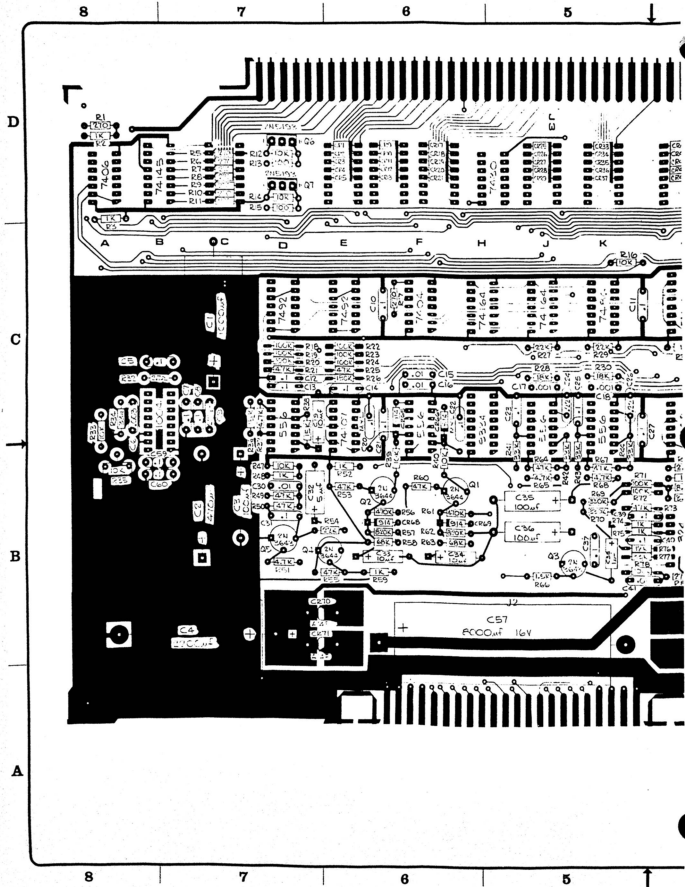

8

7

6

5

D

C

B

A

8

7

6

5

J2
C57
1000uf 16V

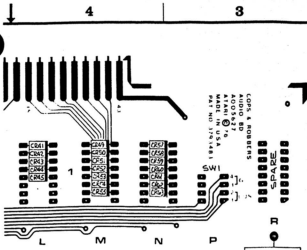

ICOPS & ROBBERS
AUDIO BD
PART NO. 1005627
MADE IN U.S.A.
REPAIR PARTS DIVISION

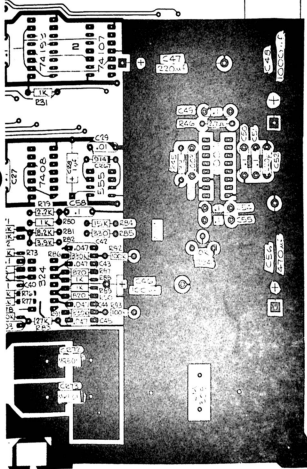

NOTES: UNLESS OTHERWISE SPECIFIED
1. ALL DIODES ARE 1N100
2. THIS ASSY DWG TO BE USED WITH
005626 REVISION 'A' P.C. BDS

CURRENT VERSION -01

NOTICE TO ALL PERSONS RECEIVING THIS DRAWING:
This drawing is the property of Atari, Inc. It is to be used for the production of parts and assemblies only. It is not to be reproduced, stored in a retrieval system, or transmitted in any form or by any means, electronic, mechanical, photocopying, recording, or by any information storage and retrieval system, without the prior written permission of Atari, Inc. The drawing is provided as a guide only and does not constitute a contract. The drawing is provided as a guide only and does not constitute a contract. The drawing is provided as a guide only and does not constitute a contract.

DATE	4/7/76
DESIGNED BY	PROJECT ENGINEER
CHECKED BY	PROJECT ENGINEER
APPROVED BY	
DATE	
DESIGNED BY	
CHECKED BY	
APPROVED BY	

DISSEMINATION THIS DRAWING PER L3487 (1-1) UNLESS OTHERWISE SPECIFIED UNCLASSIFIED ARE IN PENCIL DRAWING IS IN	DRAWN BY: <u>DATE</u> CHECKED BY: <u>DATE</u> PROJECT ENGINEER: <u>DATE</u> DOCUMENT CONTROL: _____ APPROVED BY: _____	ATARI INCORPORATED 14000 Winchester Boulevard Los Gatos, California 95030 ATARI TITLE: ASSEMBLY, ICOPS & ROBBERS AUDIO & SWITCH MATRIX BD SIZE: D DRAWING NO: A005627 REV: A WALL: 2:1 SHEET: 1 OF 1
--	--	---

DRAWING NO. A005627

A



PARTS LIST SPECIFICATION

Page 1 of 3

Drawn

Checked

Proj. Eng.

Mech. Eng.

Elec. Eng.

REV.

A

Rev.	Description	Date	Apprv.	Rev.	Description	Date	Apprv.
A	PROD. REL.	6/2/76					

Item	Part Number	Qty.	DESCRIPTION				
1	005628-01	1	P.C. BOARD				
2	10-5101	2	Res, Carb Comp, $\frac{1}{4}$ W, 5%, 100 OHM				
3	10-5102	11	" " " " " 1K "				
			R13,15				
			R2,3,31,48,52,				
			59,74,75,80,88				
			89				
4	10-5152	1	" " " " " 1.5K "				
			R66				
5	10-5103	7	" " " " " 10K "				
			R12,14,16,33,39,				
			40,47				
6	10-5123	1	" " " " " 12K "				
			R76				
7	10-5153	3	" " " " " 15K "				
			R36,38,84				
8	10-5183	2	" " " " " 18K "				
			R28,30				
9	10-5104	11	" " " " " 100K "				
			R18-20,22-24,71				
			72,78,92,93				
10	10-5154	1	" " " " " 150K "				
			R26				
11	10-52P7	2	" " " " " 2.7 "				
			R32,46				
12	10-5271	9	" " " " " 270 "				
			R1,5-11,17				
13	10-5222	1	" " " " " 2.2K "				
			R79				
14	10-5223	3	" " " " " 22K "				
			R27,29,54				
15	10-5273	1	" " " " " 27K "				
			R83				
16	10-5330	2	" " " " " 33 "				
			R34,45				
17	10-5331	1	" " " " " 330 "				
			R85				
18	10-5392	1	" " " " " 3.9K "				
			R82				
19	10-5333	5	" " " " " 33K "				
			R41-44,77				
20	10-5334	4	" " " " " 330K "				
			R69,70,86,91				
21	10-5472	4	" " " " " 4.7K "				
			R37,51,65,68				

