

CRASH

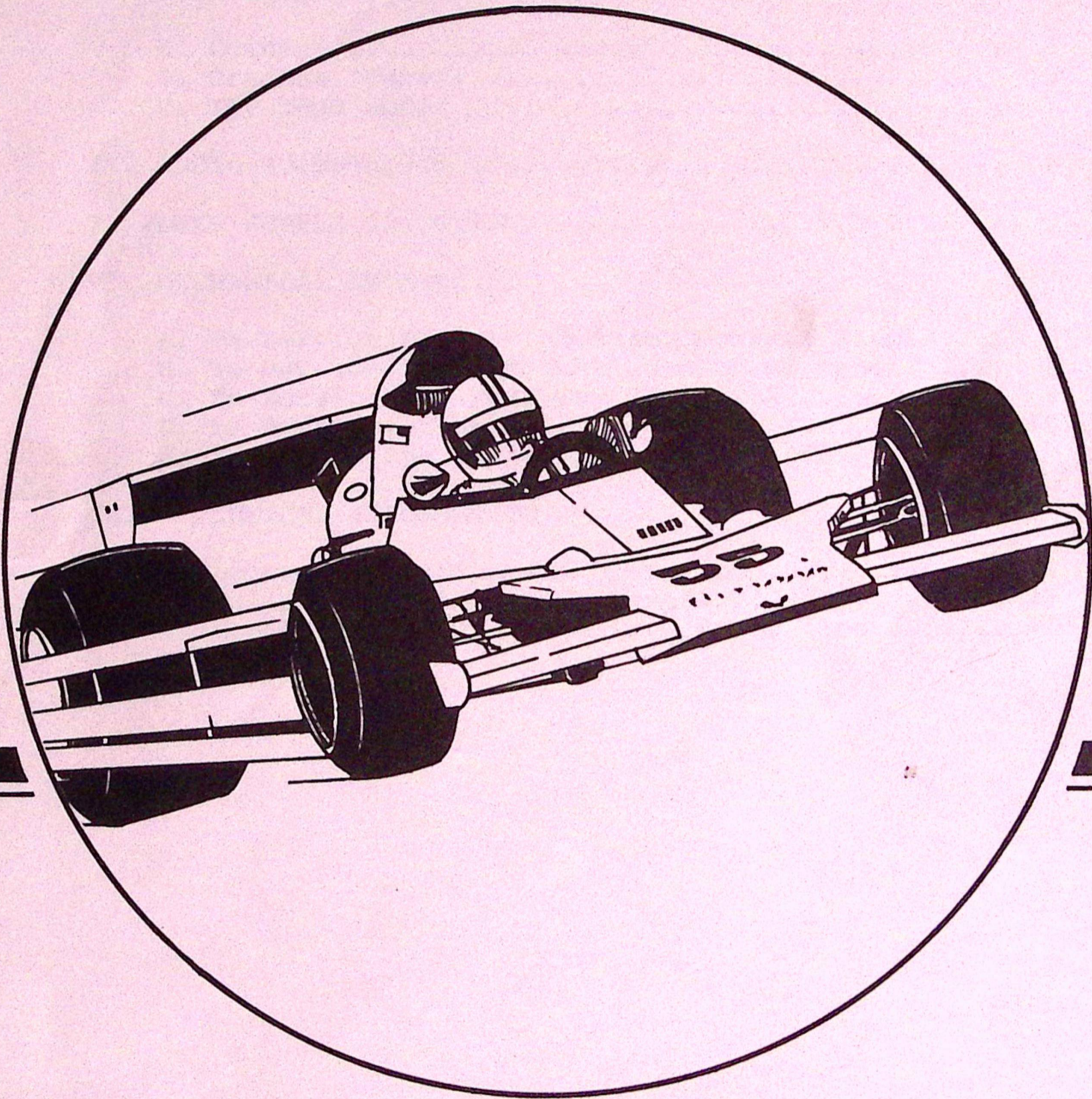

July 1979

Exidy
inc.

(c) 1979 EXIDY, Inc.

CONTENTS

I. GENERAL	3
II. NORMAL OPERATION	
A. Attract Mode	4
B. Introduction Mode	4
C. Game Play	4
III. SELECTABLE OPTIONS	
A. Coinage	5
B. Crashes (Turns)	5
C. TOP THIS SCORE	5
IV. AUDIO ADJUSTMENTS	5
V. POWER SUPPLY ADJUSTMENTS	6
VI. MECHANICAL ASSEMBLIES	
A. To Service Early-Production Control Panels ...	7
B. To Service Late-Production Control Panels	8
C. To Service the Four-Way Joy Stick	9
D. To Remove the Monitor	10
E. To Remove the Logic and Audio Boards	10
VII. TECHNICAL INFORMATION	
A. Logic Description and Operation	11
B. Audio Description and Operation	11
C. Diagrams, Pinout Table, and Schematics	14

ILLUSTRATIONS

Figure 1: Monitor Display	3
Figure 2: Audio Board Adjustments	5
Figure 3: Power Supply Adjustments	6
Figure 4: Control Panel (Early Production)	7
Figure 5: Control Panel (Late Production)	8
Figure 6: Four-Way Joy Stick	9
Figure 7: Major Internal Components	10
Figure 8: Logic Board Block Diagram	14
Figure 9: Audio Board Block Diagram	15
Figure 10: Harness Diagram	16

I. GENERAL

CRASH is a one or two player skill game in which players drive a car around a five lane square track while avoiding collisions with computer controlled drone cars. Players score points by driving over speed dots marked on the traffic lanes; players avoid collisions by changing lanes at the four traffic interchanges, and by using the FAST button to beat drone cars to interchanges.

CRASH has three coinage options. After the player inserts his coins, play instructions and the day's high score appear on screen. An optional TOP THIS SCORE feature gives a replay to the player who beats a random score.

The operator selects the number of crashes (turns) per play: 2, 3, 4, or 5.

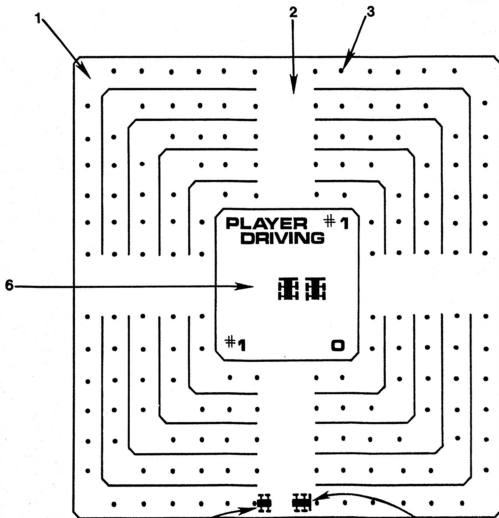

Figure 1: Monitor Display

- | | |
|----------------|-----------------|
| 1 Traffic lane | 4 Player car |
| 2 Interchange | 5 Drone car |
| 3 Speed dot | 6 Message panel |

II. NORMAL OPERATION

A. Attract Mode

When the game is first turned on, the words GAME OVER will flash on screen. Also on screen will be TODAY'S HIGH SCORE followed by a score which changes with each new higher score attained throughout the day. When the game is turned off, the high score is reset to zero.

Also displayed on screen, at the operator's selection, will be one of the following:

COIN	PLAY
2	1

or

COIN	PLAY
1	1
2	2

or

COIN	PLAY
2	1
4	2

CRASH also has a coin accumulator (credit counter) so that a player can buy a number of games in advance.

While in the attract mode (no credits, no game in progress) the game plays automatically.

B. Introduction Mode

When a player deposits a coin, the following message comes on screen:

CHANGE LANES TO AVOID
CRASH WITH OTHER CARS

10 POINTS FOR EACH DOT
BONUS POINTS IF ALL
DOTS ARE ELIMINATED

CREDITS N

TOP THIS SCORE FOR CREDIT

M

Here, N is the number of games in the credit counter, and M is a random score used by the TOP THIS SCORE feature. At the operator's option, CRASH awards one extra game to any player who matches or exceeds the score M.

C. Game Play

When a player presses one of the two START buttons (after coinage), a fanfare tune signals the start of play. The player's car starts at the bottom center of the screen (in the outer lane) and moves counter-clockwise. One drone car starts at the same place, moving in the opposite direction.

The drone car tries to crash into the player's car. The player must avoid crashes by changing lanes at interchanges; he uses the FAST button to reach an interchange before the drone car.

When the player's car drives over a speed dot, the SPEED BEEP sounds and the dot disappears. At game start, each dot scores 10 points; if the player clears all the dots in a single turn (without crashing into the drone car) the playfield is reset, and all speed dots score 20 points. Each successive time the player clears all dots, the dot score goes up: 20 points, 30 points, etc.

The number of drone cars increases with the point value of the speed dots. At game start (10 points per dot) only one drone opposes the player; at the next level (20 points per dot) two drones oppose him. At all succeeding levels (30 points and above), three drones.

A turn continues until the player crashes into a drone car. The message display in the center of the screen shows turns remaining, by displaying one car for each crash (turn) left, not counting the current turn.

III. SELECTABLE OPTIONS

CRASH has three switch selectable options. These are controlled by a seven segment DIP switch located on the main logic board at position 14A (see Figure 2, item 6). This switch is accessible from the front of the game though the coin door.

Following are the options and the switch settings for their selection:

A. Coinage	switch 4	switch 5
2 Player - 1 Coin	ON	ON
1 Player - 1 Coin	ON	OFF
2 Player - 2 Coin		
1 Player - 2 Coin	OFF	ON
2 Player - 4 Coin		
B. Crashes (Turns)	switch 6	switch 7
2 Crashes	ON	ON
3 Crashes	ON	OFF
4 Crashes	OFF	ON
5 Crashes	OFF	OFF
C. TOP THIS SCORE	switch 3	
Credit awarded for topping score	OFF	
Credit <u>not</u> awarded for topping score	ON	

IV. AUDIO ADJUSTMENTS (Figure 2)

MOTOR	-- 3 pots:
	R52=high frequency
	R53=low frequency
	R16=volume
MUSIC	-- 1 pot:
	R63=volume

VOLUME	-- 1 pot:
	R66=overall volume
CRASH	-- 1 pot:
	R29=volume
SPEED BEEP	-- 1 pot:
	R39=volume
SKID	-- 2 pots:
	R47=frequency
	R49=volume

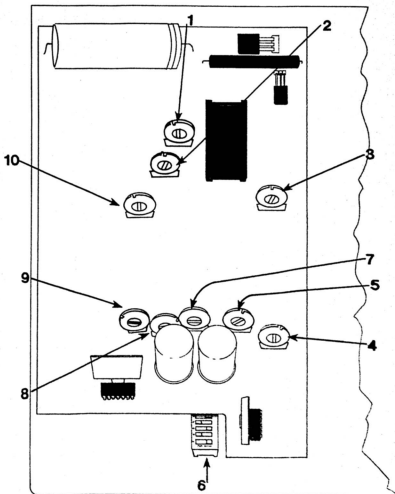

Figure 2: Audio Board Adjustments

1 R52 MOTOR	6 DIP SWITCH
2 R53 MOTOR	7 R39 SPEED BEEP
3 R63 MUSIC	8 R49 SKID
4 R66 VOLUME	9 R47 SKID
5 R29 CRASH	10 R16 MOTOR

V. POWER SUPPLY ADJUSTMENTS

1. Connect a voltmeter to the +5 and ground traces on the logic board.
2. Adjust the power supply potentiometer for $+5.0 \pm .1$ VDC (see Figure 3).

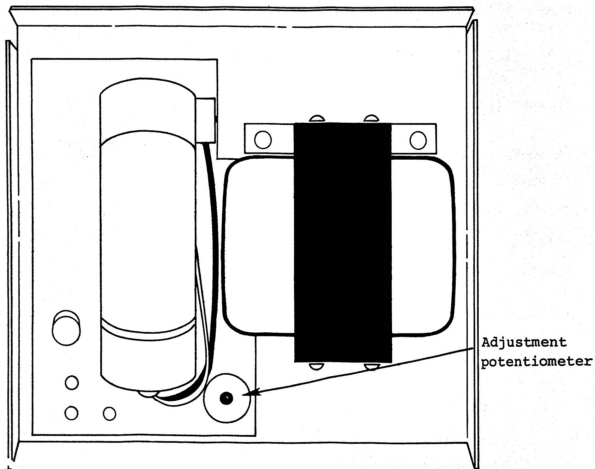

Figure 3: Power Supply Adjustments

VI. MECHANICAL ASSEMBLIES

NOTE

Each CRASH game has one of two control panels:

* A single metal plate, held by four carriage bolts (early production).

* A large metal plate, hinged at the bottom (late production).

A. To Service Early Production Control Panels (see Figure 4).

1. Unplug power cord.

2. Open the coin door.

3. Reaching up through the coin door, remove the wingnuts from the four carriage bolts that hold the control panel down.

4. Lift the control panel up from the cabinet and set it on edge, so that you can reach its underside.

5. Check all terminal connections to the pushbuttons and the four-way joy stick.

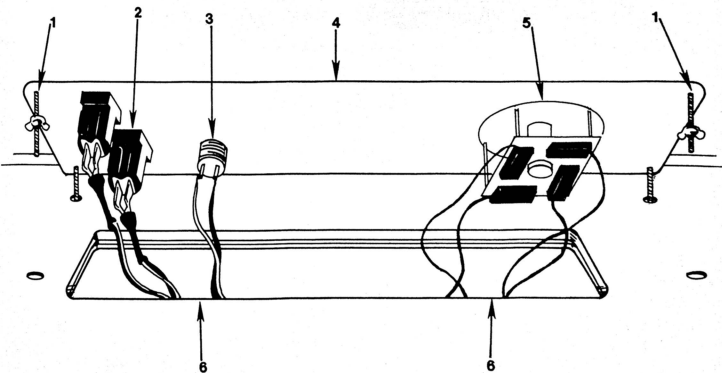

Figure 4: Control Panel (Early Production)

- | | |
|-----------------|--------------------|
| 1 Carriage bolt | 4 Control panel |
| 2 Start buttons | 5 Four-way control |
| 3 FAST button | 6 Control harness |

B. To Service Late Production Control Panels (see Figure 5)

1. Unplug the power cord.
2. Open and remove the back door.
3. From inside the cabinet, remove the three control panel nuts (see Figure 7).
4. Open the coin door.
5. From the front of the cabinet, pull the control panel out and down; let it rest on the open coin door (see Figure 5).
6. Check all terminal connections to the pushbuttons and the four-way control.

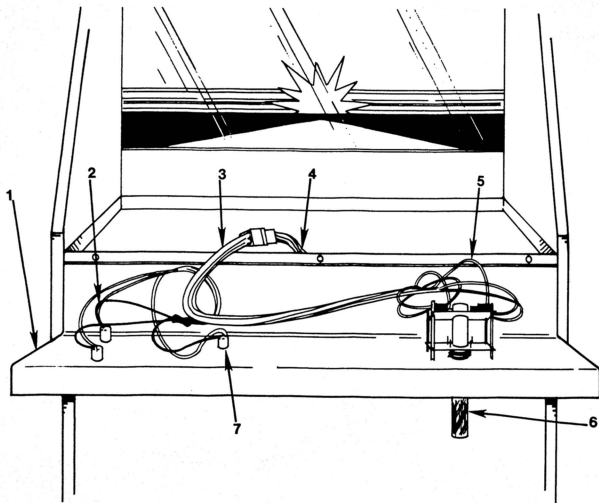

Figure 5: Control Panel (Late Production)

- | | |
|-------------------|--------------------|
| 1 Control panel | 4 Main harness |
| 2 Start buttons | 5 Four-way control |
| 3 Control harness | 6 Control stick |
| 7 FAST button | |

C. To Service the Four-Way Joy Stick

The four-way joy stick is mounted on the control panel with four long screws and standoff spacers. Four pairs of spring steel cup washers surround the control stick, between the control panel and the top plate (see Figure 6). These cup washers bear against a disk welded to the control stick, and push the stick towards its center (rest) position. Four leaf switches on the bottom plate (activated by the control stick) signal lane changes to the logic board.

To service the control:

1. Unplug the power cord.
2. Open the control panel (see above).
3. Check the harness connectors to each leaf switch.
4. Check the throw of each micro-switch; the control stick should activate, but not bottom-out against, each switch.
5. If necessary, adjust leaf switch throw by carefully bending the switch actuator with a long-nose pliers.

Figure 6: Four-Way Joy Stick

- | | |
|--------------------------|-------------------------------|
| 1 Carriage bolt | 8 Kep nut |
| 2 Control stick | 9 Switch plate (bottom plate) |
| 3 Control panel | 10 Kep nut (small pattern) |
| 4 Flat washer | 11 Leaf switch |
| 5 Cup washer | 12 Phillips screw |
| 6 Spacer | |
| 7 Lower disc (top plate) | |

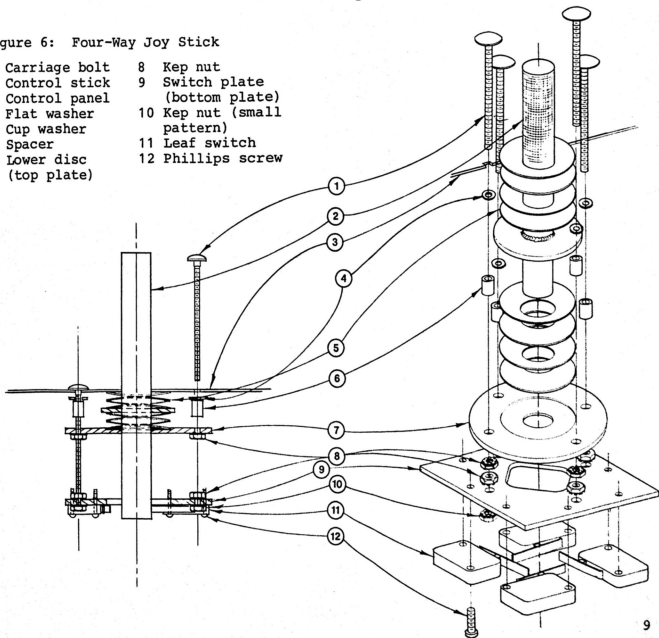

D. To Remove the Monitor

1. Unplug the power cord.
2. In some cabinets, the monitor is not accessible through the back door. A monitor access panel above the back door is secured with four wood screws.
3. Open and remove the back door or monitor access panel.
4. Unplug the harness connector from the monitor.
5. Remove the four bolts from the monitor chassis flange mounts.

6. Lift the monitor up and slide it out of the cabinet.

E. To Remove the Logic and Audio Boards

1. Unplug the power cord.
2. Open and remove the back door.
3. Clip the plastic tie wraps which hold the boards in their rack.
4. Disconnect the edge connector from the logic board.
5. Slide the boards out of their rack.

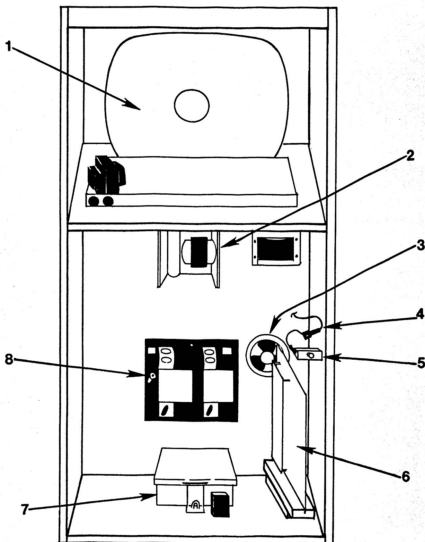

Figure 7: Major Internal Components

- | | |
|----------------|--------------------|
| 1 Monitor | 5 Interlock switch |
| 2 Power supply | 6 PC boards |
| 3 Speaker | 7 Cash box |
| 4 In-line fuse | 8 Coin door |

VII. TECHNICAL INFORMATION

A. Logic Description and Operation (see Figure 8)

CRASH uses the 6502 central processor unit. (For more information on this processor, refer to MOSTEK publication #6500-10A, MCS Microcomputer Family Hardware Manual.)

This processor is unique in that it does not have a separate input/output structure, but treats all I/O as if it were an area of memory. Memory is mapped as follows:

FFF8-FFFF	Interrupt and reset vectors
F000-FFF7	Program storage (PROM)
D000	Four-way control and interrupt reset
C000	Option switches (input)
A000	Control switches (input)
8000	Player car rotation and audio control bits (outputs)
4000-43FF	Screen RAM
3000	Player car horizontal position (controls)
2000	Player car vertical position (controls)
1000-1FFF	Program storage (PROM)
0100-01FF	Stack RAM
0000-00FF	Base page RAM

Base page RAM holds variables while the game program is running; the stack RAM holds return addresses and important data during subroutines. The program storage PROM holds the program which controls the operation of the game.

The screen RAM consists of 1024 bytes (8-bit words) of read/write memory. When not being addressed by the processor, this RAM is scanned by main timing, to display a 32 x 32 matrix of squares on the screen. The data stored in the screen RAM is then used to select one of 256 images from the screen ROM (each image is 8 elements wide and 8 lines tall). Note that the

processor never addresses screen ROM directly (see Figure 8).

The 8 x 8 images selected from screen ROM fit together to form the display on screen. An alphanumeric character consists of a single 8 x 8 image, while the player's car and the crash explosion are each made up of several images.

Example:

To store the letter "X" in the upper left corner of the screen, the processor would write 29H in memory location 4000H.

The player car is generated by two sets of counters (horizontal and vertical) which are used to position the image on screen. The outputs of the counters, along with the rotation information in 8000H, are fed to the player car PROM to form the car's image. The processor controls the car by preloading the counters to the desired position during vertical sync.

The processor reads data from the switches by gating the data from the control or option switches onto the data bus when the appropriate address is selected.

B. Audio Description and Operation (see Figure 9)

The audio board is powered by +5 VDC from the logic board and +15 VDC developed on the audio board itself. The AC power source for the +15 VDC comes from an external transformer which steps down the 115 VAC line voltage.

The audio board contains the following circuits:

- * +15 VDC regulated power supplies
- * audio amplifier

- * white noise generator
- * speed beep sound generator
- * crash sound generator
- * skid sound generator
- * motor sound generator
- * music input
- * yoke polarity driver

Following are brief descriptions of these circuits:

The +15 VDC Power Supply

The first stage of the +15 VDC supply is a full wave rectifier which converts the input 35 VAC (center-tapped) to approximately +25 VDC. This later DC voltage is not critical, however, and may vary from transformer to transformer.

The second stage is a self-contained 3-lead regulator chip (LM 340T - VR1) which converts the +25 VDC to +15 VDC. This +15 VDC source feeds most audio circuits, and the base of transistor Q1. This source is a relatively low current supply, so pass transistor Q1 provides a higher current at +15 VDC for the audio amplifier chips (LM 380N or equivalent). Transistor Q1 is configured as an emitter follower, so the emitter voltage will equal the regulated +15 VDC minus approximately .7 VDC (the normal drop across the base-emitter junction for a silicon transistor at or near saturation).

The White Noise Generator

The white noise is produced by the thermal breakdown of a transistor junction. Q2 has a grounded base, an open collector, and an emitter tied to the +15 VDC current source. The base-emitter junction is reverse biased so much that it breaks down, generating broad band noise.

U1 amplifies Q2's output. U1's output is a high impedance current source and would be easily loaded down by other audio circuits; the single stage amplifier Q3 prevents this loading, and provides a low impedance source for driving other circuits.

The Speed Beep Sound Generator

U11A is wired as a triggered oscillator (one shot); U11B is wired as a VCO and amplifier, with volume controlled by R39. The processor sends a signal when a speed dot is erased. This pulse triggers U11A, which enables U11B for the one shot period.

The Crash Sound Generator

The crash sound is triggered by a negative-going TTL pulse from the logic board. Transistor Q6 receives no base current until the incoming signal 5 CRASH forward biases diode CR7, creating a base current path charging capacitor C15. When the input signal is removed, diode CR7 is once more reverse biased, leaving the charged C15 to keep the circuit on for a period determined by the RC combination C15, R24.

This circuit, however, does not oscillate. It merely amplifies the white noise previously generated, and thus is like an amplifying switch with a small turn-off delay. C11, C19 and R11 form a damped-wave decay network. A diode in the collector of Q6 provides output isolation.

The Skid Sound Generator

The skid sound is enabled by a TTL low level input from the logic board. This generator consists of a voltage controlled oscillator (used as a tone generator) and an amplitude modulator used to shape the sound volume.

When there is no input signal, transistor Q11 is saturated, thus holding U4 pin 5 (the input to the VCO) relatively low and U5 pin 2 (the control input to the amplitude modulator) relatively high. This voltage at U5 pin 2 holds the output OFF.

Note that one end of a 68K resistor is tied to the base of Q11 and the other end is tied to the output of U3, an open-collector gate. Given a TTL low level on the input of this gate, the output drives toward ground, thus making the 68K resistor effectively the bottom part of a resistor divider on the base of Q11.

This would immediately rob Q11 of most of its base current and cause the collector voltage to rise, if not for the 6.8 uF capacitor in the upper half of the divider. This capacitor takes time to discharge, and thus the collector voltage rises gradually. This changes the VCO frequency gradually from low to high.

Since the emitter voltage is the amplitude control input to U5, this also enables the output of the modulator U5 in the same manner (except that a descending voltage increases the output amplitude).

The duration of the input signal 5 SKID determines the duration of the skid sound directly. The output is fed directly to the audio input bus.

The Motor Sound Generator

The Q4 - U10 circuit generates the motor sound in much the same way that the Q11 - U4 circuit generates the skid sound. The low motor/high motor input is selected by the position of the control panel FAST button. R52 and R53 control the motor sound frequencies, not the volume. R16 is the volume control.

The complements of both the low and high fundamental frequencies are present at the collector of Q12. The input U10-5 has the composite of all fundamentals and harmonics.

The Music Input

The music is generated entirely by the microprocessor on the logic board, out of software. The input on the audio board simply consists of an isolation and volume control network, prior to passing the signal to the audio drivers (U7 and U8).

The Yoke Polarity Driver

This circuit is used only in cocktail table models of CRASH, where the video display must be turned over in order for a player on either side of the table to see an upright picture when it is his turn to play. The circuit is a single D type flip-flop driving a transistor (MJE 182). When this transistor is turned on the collector drives toward ground, thus supplying the yoke relay with the ground it needs to energize and reverse the yoke leads in the video monitor.

The flip-flop U2 is set by a negative-going TTL pulse from the logic board to U2 pin 2; this inverts the picture. U2 is reset by a negative-going pulse from the logic board to pin 13.

C. Diagrams, Pinout Table and Schematics

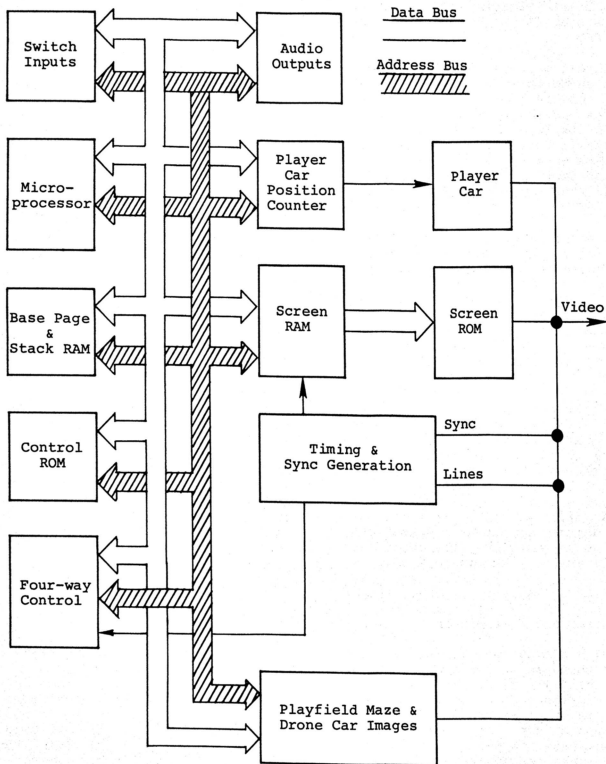

Figure 8: Logic Board Block Diagram

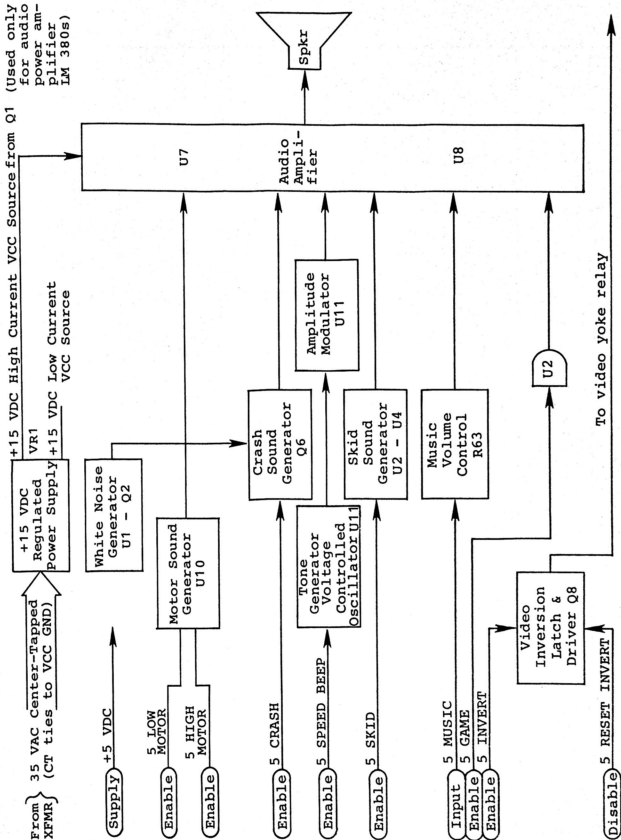

Figure 9: Audio Board Block Diagram

Pinout Table

From	To	Signal	From	To	Signal
J1-1	J5-5	1 player start	J7-1	VCC	5 V out
J1-2	J5-11	Four-way down	J7-2	GND	5 V common ground 35 V CT
J1-3	J5-8	Four-way left	J7-5	35 VAC	
J1-4	J5-10	Four-way up	J7-6		
J1-5	J5-7	Four-way right	J9-1	E2	AC interlock out
J1-6	J5-9	FAST	J9-2	Plug	AC common
J1-7	J5-6	2 player start	J9-3	Plug	AC ground
J1-8		Unused	J10-1	leads 1 & 3	35 V transformer 110 VAC in
J1-9	(J4-2) (J5-2)	Ground	J10-2	leads 2 & 4	
J2-A	J3-10	AC lo (used only for 110 VAC lamp versions)	J15-1	6.3 V	6.3 VAC out
J2-B	J3-9	AC hi	J15-2		
J3-1	J5-4	Video out	J10-1		110 VAC hot
J3-2	J5-3	Ground	P9-1	TRM 1 & 3	110 VAC to 5 V power supply
J3-7	P10-3	AC gnd	P9-2		
J4-1	J5-1	VCC 5 VDC	P9-2	TRM 2 & 4	AC to 5 V power supply
J4-2	J5-2	Ground	P9-3	J10-3 chassis ground	AC ground
J4-3	J5-12	Coin norm. open	P15-1	P16-1	6.3 VAC supply
J5-13	Open	Static antenna*	P15-2	P16-2	6.3 VAC common
J5-14	Power supply gnd, P7-2	35 VAC CT grounded	E1	F1-B	AC hot (fused to interlock switch)
J5-15	P7-5	35 VAC			
J5-16	P7-6				
J5-20	J6-A	Speaker out			
J5-21	J6-B				

* The static antenna is a six inch long wire in the harness. One end is connected to J5-13; the other

end is free. Cut 1/4" pieces off as needed, until static discharges no longer turn on the game.

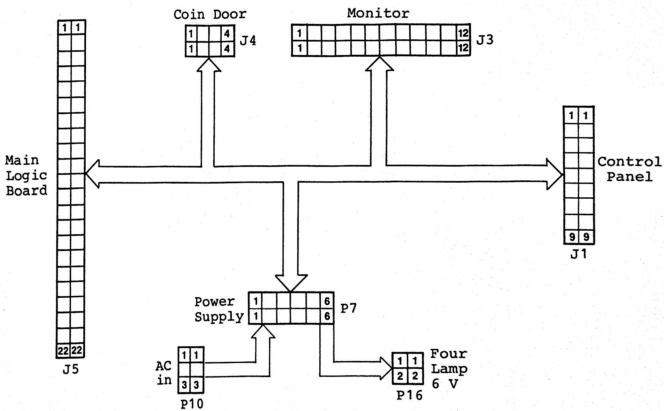
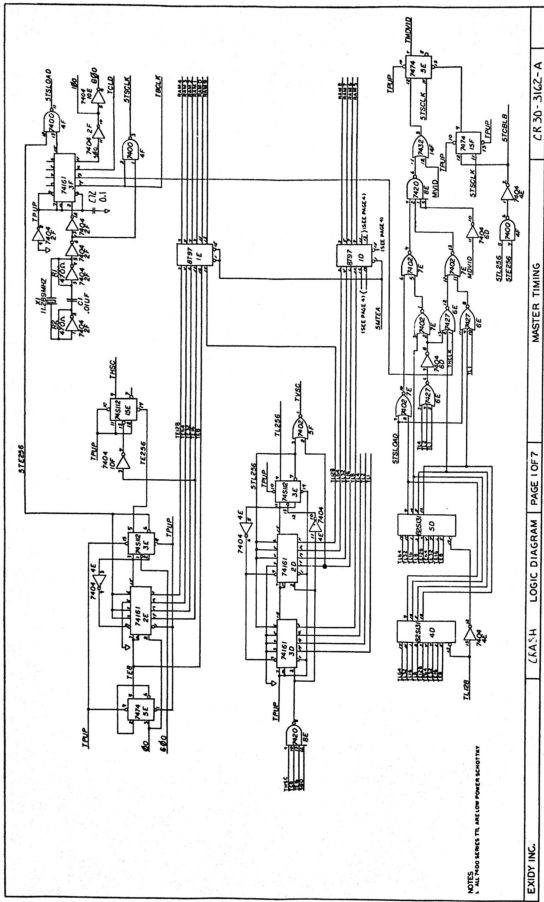
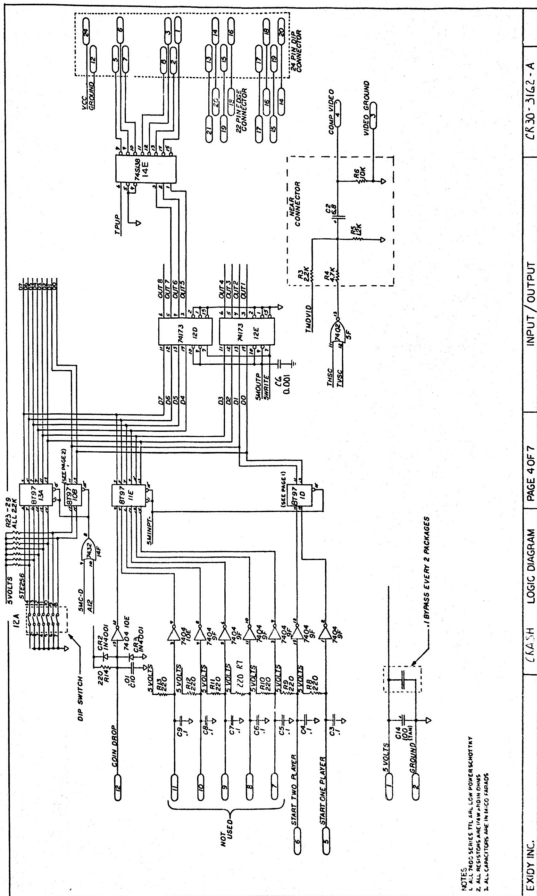

Figure 10: Harness Diagram



NOTE: ALL 7400 SERIES TTL ARE LOW POWER SCHOTTKY



NOTES:
 1. ALL THIS SERIES TTL, ALL LOW POWER EMITTER
 2. ALL LOGIC IS ACTIVE LOW UNLESS OTHERWISE NOTED
 3. ALL CONNECTIONS ARE IN ACCORDANCE

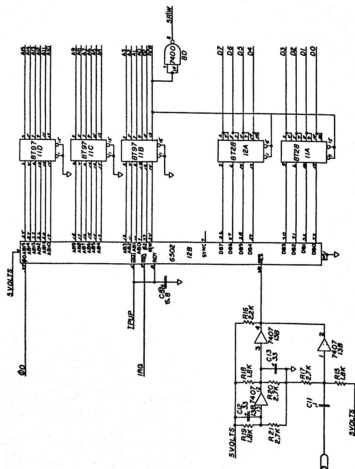
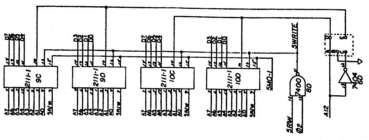

NOTES
 1. ALL LOGIC DEVICES ARE LOW POWER QUANTITY EXCEPT 7407
 2. ALL RESISTORS ARE 1/4W AND 5% TOL.
 3. ALL CAPACITORS ARE IN MICRO FARADS

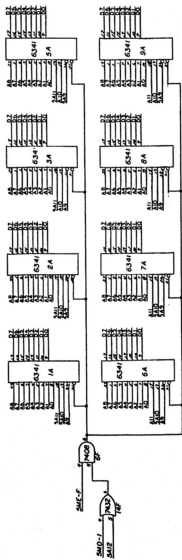

NOTES
 1. ALL REGISTER'S TTL ARE LOW POWER SORTKEY

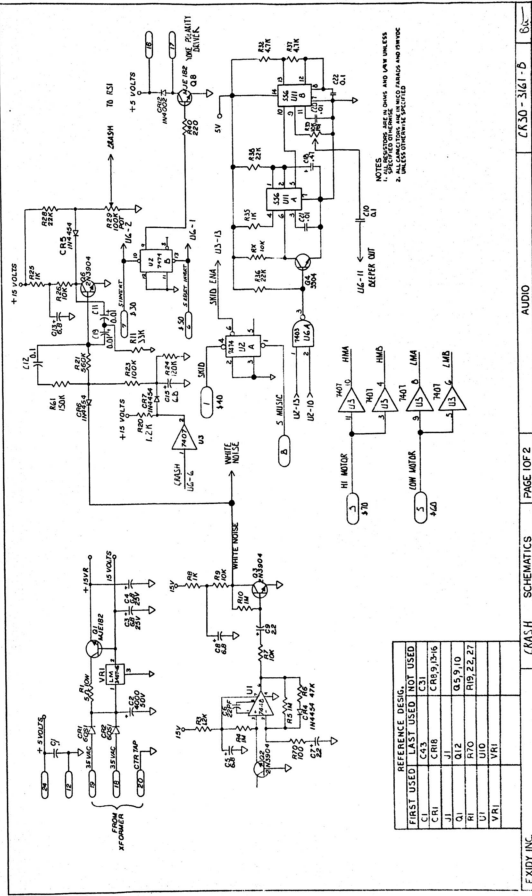

NOTES:
 1. ALL RESISTORS ARE IN OHMS, AND LAWS UNLESS
 OTHERWISE SPECIFIED.
 2. ALL CAPACITORS ARE IN MICRO FARADS, UNLESS
 OTHERWISE SPECIFIED.

REFERENCE DESIG.	FIRST USED	LAST USED	NOT USED
C1	C43		
CRI	C18		
CI	C18		
CR1	CR9, D16		
CI	C31		
J1	J1		
Q1	Q12		
R1	R70		
R10	R19, 22, 27		
UI	UI0		
VRI	VRI		

