

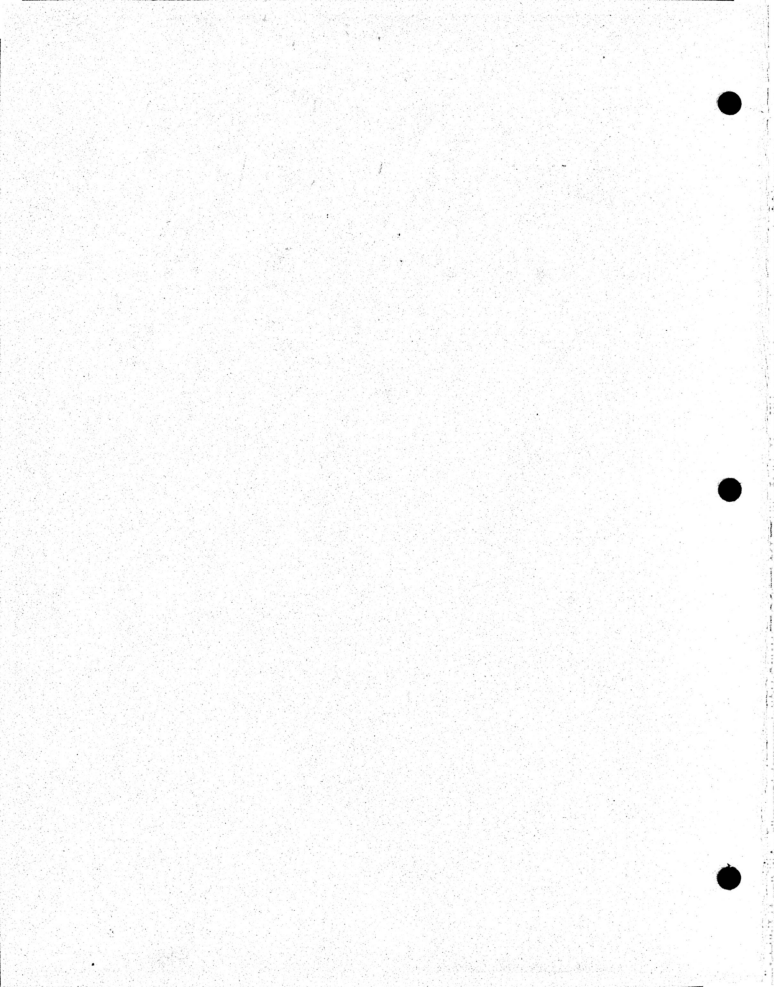

CRAZY CLIMBER



CRAZY CLIMBER-UPRIGHT

TABLE OF CONTENTS

1. CRAZY CLIMBER GAME SET-UP

- A. Introduction
- B. Game Inspection
- C. Game Installation
- D. Dip Switch & Volume Control Settings

2. MAINTENANCE

- A. Cleaning
- B. Fuse Replacement
- C. Video Monitor Removal
- D. Video Monitor Adjustments
- E. Fluorescent Bulb Replacement
- F. Printed Circuit Board Replacement

3. ILLUSTRATIONS AND PART LISTS

- Figure 1 Video and Cabinet Assembly
- Figure 2 Coin Mechanisms and Front Door
- Figure 3 Switching Regulator & Cabinet Parts
- Figure 4 8-Way Joystick Assembly
- Figure 5 Control Panel
- Figure 6 CPU Board "A" & Component List
- Figure 7 CPU Board "B" & Component List
- Figure 8 Option Switch & Volume Control Locations
- Figure 9 Wiring Diagram
- Figure 10 PCB Board "A" Schematic (FOLD OUT)
- Figure 11 PCB Board "B" Schematic (FOLD OUT)

INTRODUCTION

TAITO AMERICA'S CRAZY CLIMBER UPRIGHT is a skill based video action game, with speech, designed for one or two players.

The object of the CRAZY CLIMBER game is to advance the climber to the top of each skyscraper attempting to avoid the various obstacles. A player can scale up to a total of four skyscrapers. A player accumulates point value for climbing and then receives these points if he is picked up by the helicopter at the top of each skyscraper. If the player misses the next helicopter the bonus points are lost and the player advances to the next skyscraper. An additional climber is displayed if the players score reaches 30,000 points (adjustable).

GAME INSPECTION

TAITO AMERICA'S CRAZY CLIMBER game is ready to play when received. However, careful inspection is necessary to insure your game is in perfect condition. Please verify the following before turning the game on.

- Examine external parts for chips, dents, or broken parts.
- Open the service door and examine the following:
 - Plug-in connectors to make sure they are firmly seated.
 - Speaker
 - Player controls
 - Printed circuit boards making sure there is no damage to the components.
 - Check for loose foreign objects especially metal objects which may cause electrical problems.
 - Fuses, making sure they are firmly in the holders.
 - Transformer
 - Coin Mechanisms

If problems occur or technical assistance is required, contact our Customer Service Department HOT LINE Toll Free 800-323-0666 (except Illinois). Illinois phone 981-1000 X 215.

The Video Monitor is properly adjusted before shipping, if there are any adjustments necessary refer to the manufacturers operating manual.

POWER REQUIREMENTS

TAITO AMERICA'S CRAZY CLIMBER game is shipped ready for operation at 120VAC, 60Hz with a power consumption of approximately 250 Watts.

CAUTION

For safe operation it is recommended the cabinet be grounded. This game is equipped with a three conductor power cable. The third conductor is the ground conductor and when the cable is plugged into an appropriate receptacle, the game is grounded. The offset pin on the power cable's three-prong connector is the ground connection.

LOCATION SPACE REQUIREMENTS

- Depth - 35" (87.5cm)
- Width - 24" (61cm)
- Height - 68" (171cm)
- Weight - 300 lbs. (135Kg)

INSTALLATION REQUIREMENTS

The following precautions should be followed when installing the game.

- Avoid rough handling of the game, the picture tube is fragile.
- Install the game on a level surface.
- Avoid installing the game where it may receive excessive sunlight or heat, to prevent the game from rising internal temperature.
- Do not install in a damp or dusty location.
- For a short time after connecting the power to the game, the picture may be temporarily distorted.

DIP SWITCH AND VOLUME CONTROL SETTINGS

DIP SWITCH SETTINGS

TAITO AMERICA'S CRAZY CLIMBER game provides the following option switches. See Figure 8. These options can be found on PC Board "A" Switch B.

SW 1 and SW2 are used for selecting the number of climbers. Switches 1 and 2 are preset at the factory for 4 climbers.

CLIMBERS	SW1	SW2
3	OFF	OFF
4	ON	OFF
5	OFF	ON
6	ON	ON

TABLE 1 CLIMBER OPTION

- SW3 is not used and should be kept in the OFF position.
- SW4 when in the ON position displays a test pattern and runs through four screens.
- SW5 & SW6 are used for coin selection. Switches 5 and 6 are preset at the factory for 1 coin - 1 play.

COIN SELECTION	SW5	SW6
1 coin - 1 play	OFF	OFF
2 coin - 1 play	ON	OFF
3 coin - 1 play	OFF	ON
4 coin - 1 play	ON	ON

TABLE 2 COIN SELECTION OPTION

- SW7 is used for adjusting the score at which time an additional climber is added. SW7 is present at the factory for 30,000 points.

SW7	OFF	30,000
	ON	50,000

TABLE 3 CLIMBER SCORING OPTION

- SW7 & SW8 are normally in the OFF position unless used for a free play. Then both switches should be in the ON position.

NOTE

Switches must not be adjusted unless the power is off.

VOLUME CONTROL SETTING

- VR. This option switch is used to control the volume. See Figure 6. Volume goes down in turning as the arrow indicates.

MAINTENANCE

All games require a certain amount of maintenance to keep them in good condition. A periodic check of mechanical controls would be beneficial to guarantee your game will be profitable.

CLEANING

The exterior of the game, all metal parts and all plastic parts can be cleaned with a non-abrasive cleanser. Caution should be used when cleaning the plastic, a dry cloth can cause scratches and result in a foggy appearance.

FUSE REPLACEMENT

This game uses six fuses, 5 are located on the Switching Regulator. See Figure 3 for size and part number of fuses. One fuse is located on the Power Supply itself.

VIDEO MONITOR REMOVAL

If you need to remove the video monitor, follow the instructions listed below:

CAUTION

It is recommended the game be left disconnected for at least one hour before removing the video monitor. This will probably discharge the video tube but extreme caution is still necessary.

- Remove power from line voltage.
- Disconnect the monitor and cable connector.
- Remove wire cable clamp.
- Take out the two side bolts, one on each side of the cabinet.
- Lower the monitor to rest on the lower set of wood supports.
- Remove the four mounting bolts and disconnect the green ground wire.
- Slide the monitor out by pulling the monitor towards you.

CAUTION

Use extreme caution and do not touch electrical parts of the monitor yoke area with your hands or with any metal object in your hands! High voltages may exist in any monitor, even with power disconnected.

VIDEO MONITOR ADJUSTMENTS

The Video Monitor is factory adjusted. If there is a need for readjustments after the game has been shipped please refer to the manufacturers operating manual.

FLUORESCENT TUBE REPLACEMENT

CAUTION

If you drop a fluorescent tube and it breaks it will explode!
Please use care when replacing.

To replace the fluorescent bulb the control panel must be removed. With both hands turn the bulb toward you and carefully pull out of the lamp socket.

PRINTED CIRCUIT BOARD REPLACEMENT

You may wish to remove the CRAZY CLIMBER printed circuit boards for replacement or service. Follow the procedure below.

To remove the "A" Board (08-00005-002) and/or the "B" Board (08-00005-003) slide the double layered board set out of the guides.

WARNING

This equipment generates, uses, and can radiate radio frequency energy and if not installed and used in accordance with the instruction manual, may cause interference to radio communications. As temporarily permitted by regulation it has not been tested for compliance pursuant to Subpart J of Part 15 of FCC Rules, which are designed to provide reasonable protection against such interference. Operation of this equipment in a residential area is likely to cause interference in which case the user at his own expense will be required to take whatever measures may be required to correct the interference.

VIDEO AND CABINET ASSEMBLY

FIGURE 1

ITEM	TAITO PART NO.	DESCRIPTION	REFERENCE
1	47-00001-001	Screened Acrylic Marquee Panel	400073
2	27-00001-001	Fluorescent Tube, Std., 15W	AA054711
3	42B-00057-001	Fluorescent Lamp Panel	140006
4	26-00004-001	Lamp Socket (Holder)	113000
5	61C-00007-001	Glass Stop Bracket	500024
6	26-00005-001	Starter Socket	114001
7	29-00003-001	Starter	114000
8	18-00002-002	Ballast Transformer	010006
9	61B-00011-001	"L" Bracket	AA013584
10	04-00008-001	Cabinet Assembly	860007
11	63B-00006-001	T Molding, Chrome	400007
12	59-00008-001	Clamp Fastener	390002
13	47D-00002-001	Cover Glass Assembly	148011
14	63C-00003-001	Monitor Shroud	400005
15	61C-00016-001	Glass Retaining Bracket	500022
16	44C-00001-001	Caster	520000
17	63B-00005-002	L Molding, Black, 22½" Long	400031-A
18	63B-00005-003	L Molding, Black, 33¾" Long	400031-B
19	31-00001-001 31-00001-002	Monitor, 19" Color	840017
20	61C-00004-001	Video Mounting Bracket	500026
21	45-00001-001	Anchor Plate	600005-C
22	45-00001-001	Service Lock & Key	600005
23	41C-00035-001	Cabinet Back	143003
24	61B-00027-001	Ventilator Screen	EP030010
25	500086	Bracket Top	AA013580
26	500088	Cash Case	AA028507
27	400050	Cash Box	AA028506
28	600007	Lock Plate	AA013583
29	500089	Cash Box Door	AA026512
30	600006	Lock (Cash Box) & Key	AA016545
31	500060	Coin Funnel	AA025510
32	500062	Coin Funnel Plate	AA013690
33	130000	Counter, 6V DC	AA051717
34	500091	Counter Bracket	AA013608
35	63B-00006-004	U Channel Black	400025
36	500087	Bracket Bottom	500087
37	800011	Counter Drive Credit Board	AAM50012
38	100028	10 Position Edge Connector	AA055720
39	500035	Credit Board Bracket	
*40	08-00005-002	PCB "A"	
*41	08-00005-003	PCB "B"	

*Not Shown on Figure 1

VIDEO AND CABINET ASSEMBLY

FIGURE 1

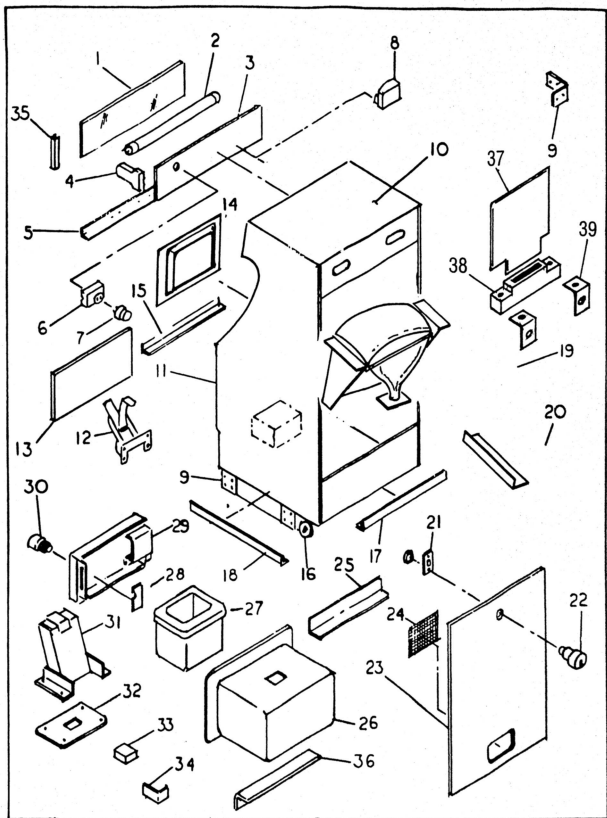

COIN MECHANISM AND FRONT DOOR ASSEMBLY

FIGURE 2

ITEM	TAITO PART NO.	DESCRIPTION	REFERENCE
1	500010	Door Frame	AA026510
2	400047	Price Card U.S. 25¢	AA029512
3	110000	Pilot Lamp, 12V, 150Ma.	AA054704
4	113001	Vinyl Socket	AA055698
5	500124	Coin Entry Plate for 25¢	
6	600002	Service Lock & Key No. 7900	AA016558
7	120017	Taito Name Tag	
8	500009	Coin Rejector Door	AA026511
9	50021-E	Cover Plate	AA019522
10	104000	Mate-N-Loc Pin A	AA055789
11	103007	Mate-N-Loc Housing 9P	AA055581
12	103008	Mate-N-Loc Housing 9P	AA055582
13	104001	Mate-N-Loc Pin 1B	AA055790
14	500021-1	Lock Plate	AA013578
15	500021-G	Coin Guide (B)	AA025508
16	500021-H	Coin Guide (A)	AA025507
17	500021-J	Tilt Switch	AA068717
18	500058	Lock Guard	AA013577
19	500021-K	Rejector Button	AA027504
20	500021-L	Spring Cancel Holder	AA015504
21	024502	Service Switch	
22	500021-M	Cancel Lever	AA013557
23	500021-N	Rejector Bracket	AA013554
24	500021-P	Rejector Holder	AA023501
25	500054	Coin Guide	AA025503
26	199005	Insulator	AA019502
27	020502	Micro Switch	AA052512
28	370002	Actuator	AA053501
29	500021-R	Rejector Lever Connector	

COIN MECHANISM AND FRONT DOOR ASSEMBLY

FIGURE 2

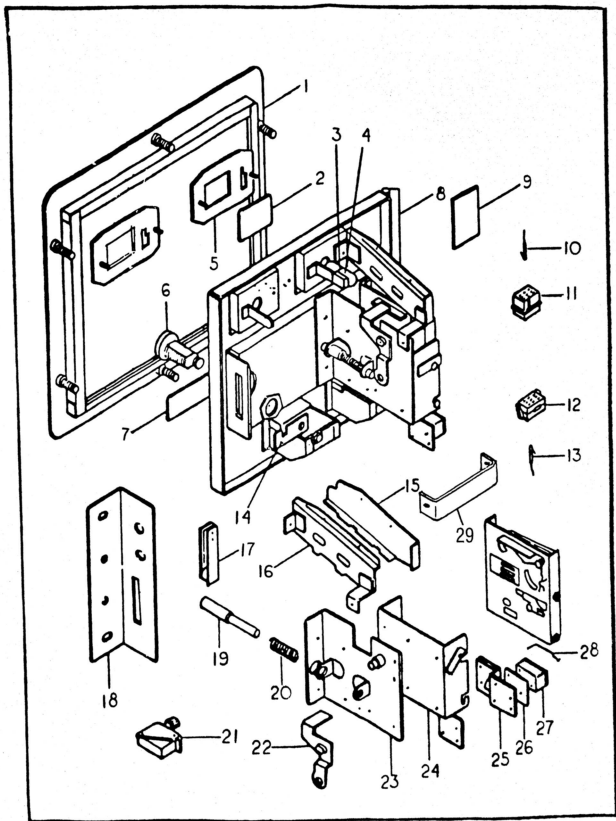

SWITCHING REGULATOR & CABINET PARTS

FIGURE 3

ITEM	TAITO PART NO.	DESCRIPTION	REFERENCE
1	800010	Switching Regulator PCB Assembly	AAM60009
2	998702	Shield Box	AA013613
3	22B-00001-001	Power Line Filter	
4	26-00003-001	Service Outlet	
5	24-00002-002	Fuse, 1.5 AMP, 3AG, Slo-Blo, 250V	
5A	24-00002-001	Fuse, 3AMP, 3 AG, Slo-Blo, 250V	
6	24-00001-001	Fuse Holder	
7	35-00001-001	Barrier Strip, 8 Position	
8	42-00034-001	Power Board	
9	61-00030-001	Switch, Interlock	
10	29-00004-001	Toggle Power Switch	
11	35B-00002-001	Insulating Shield	
12	500025	Toggle Switch Bracket	
13	18A-00001-001	Isolation Transformer	
14	998962	Noise Filter	AAT61017
15	998703	Shield Cover	
16	61B00003-001	Bracket Interlock Switch	

SWITCHING REGULATOR & CABINET PARTS

FIGURE 3

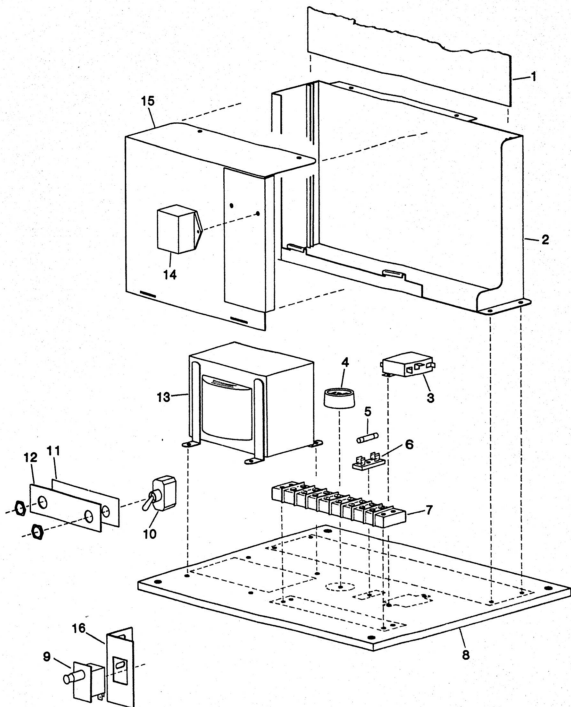

8-WAY JOYSTICK ASSEMBLY

FIGURE 4

ITEM	TAITO PART NO.	DESCRIPTION	REFERENCE
1	400026	Color Ball	BP090003
2	500153	Control Lever	UW020001
3	400030	Mask	RT090009
4	500154	Joystick "Base"	RF030002
5	390041	Plain Washer	AAL61027
6	370007	Spring	RF060001
7	500155	Joystick "Base"	RF030003
8	500156	Center Ball	RF020005
9	500157	Center Ball Cover	RF030004
10	500158	Collar	RF020002
11	500159	Actuator Push Plate	RF030007
12	500160	Push Plate Guide	RF030005
13	500161	M.S. Base	RF030001
14	390042	Spacer	RF020003
15	020503	Micro Switch	AA052532
16	199010	Insulator V Type	AA019504
17	500162	Block	RF020006
18	390043	Snap Pin	
19	500163	Lock Plate	RF030006

8-WAY JOYSTICK ASSEMBLY

FIGURE 4

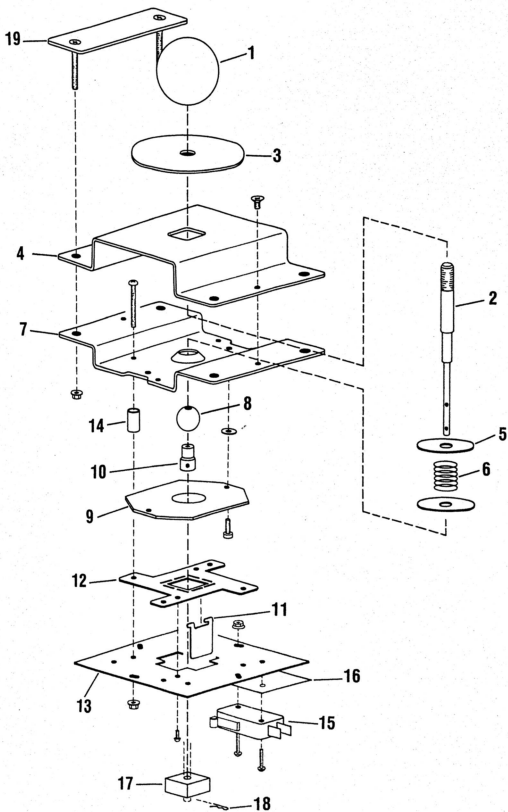

CONTROL PANEL ASSEMBLY**FIGURE 5**

ITEM	TAITD PART NO.	DESCRIPTION	REFERENCE
1	998590	Push Button Assembly (White)	
2	47C00003-001	Control Panel (Aluminum)	
3	42D00033-001	Control Panel (Wood)	
4	020501	Micro Switch	
5	199010	Insulator	
6	355000	Pal Nut	
7	500018	Switch Button Bracket	
8	63A00021-001	Mask	
9	850042	Joystick Assembly (8-Way)	UWK00005
10	63A00020-001	Knob & Shaft	
11	61A00015-001	Strike Hook	

CONTROL PANEL ASSEMBLY

FIGURE 5

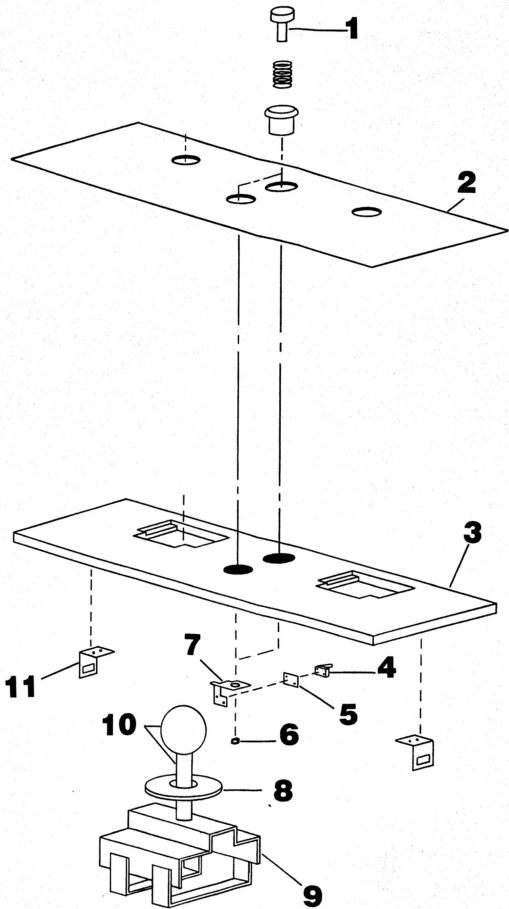

CPU BOARD "A" & COMPONENT LIST

FIGURE 6

ITEM	TAITO PART NO.	DESCRIPTION	REFERENCE
1	79-00013-001	PCB Sticker	AAO 55786
2	26-00001-022	IS2 - IC Socket 22P	AAO 55999
3	26-00001-024	IS3 - IC Socket 24P	AAO 55787
4	25-00021-001	50P Angle Pin Header	AAO 55154
5	25-00004-001	PCB Conn. PCN364J040AG	
6	19-00003-001	XIN X-Tal 18.432 Mhz	AAO 69590
7	15-20000-001	IC 1 LS IC 74LS00	AAO 33001
8	15-20002-001	IC 2 LS IC 74LS02	AAO 33003
9	15-20004-001	IC 3 LS IC 74LS04	AAO 33005
10	15-20008-001	IC 4 LS IC 74LS08	AAO 33009
11	15-20010-001	IC 5 LS IC 74LS10	AAO 33011
12	15-20011-001	IC 6 LS IC 74LS11	AAO 33012
13	15-20021-001	IC 7 LS IC 74LS21	AAO 33021
14	15-30025-001	IC 8 TTL IC 7425	AAO 32006
15	15-20032-001	IC 9 LS IC 74LS32	AAO 33027
16	15-20074-001	IC10 LS IC 74LS74	AAT 33051
17	15-20086-001	IC11 LS IC 74LS86	AAT 33062
18	15-20107-001	IC12 LS IC 74LS107	AAT 33076
19	15-20139-001	IC13 LS IC 74LS139	AAT 33097
20	15-20157-001	IC14 LS IC 74LS157	AAT 33112
21	15-20161-001	IC15 LS IC 74LS161	AAT 33116
22	15-20163-001	IC16 LS IC 74LS163	AAT 33118
23	15-20174-001	IC17 LS IC 74LS174	AAT 33127
24	15-20175-001	IC18 LS IC 74LS175	AAT 33128
25	15-20194-001	IC19 LS IC 74LS194	AAT 33144
26	15-20245-001	IC20 LS IC 74LS245	AAT 33157
27	15-20273-001	IC21 LS IC 74LS273	AAT 33170

ITEM	TAITO PART NO.	DESCRIPTION	REFERENCE
28	15-20283-001	IC22 LS IC 74LS283	AAT 33176
29	15-20367-001	IC23 LS IC 74LS367	AAT 33203
30	15-20368-001	IC24 LS IC 74LS368	AAT 33204
31	15-10008-001	IC25 Static Ram MBB1014	
32	15-10003-001	IC26 Static Ram MBB114NL	AAT 32156
33	15-10009-001	IC27 Static Ram D2115A	AAT 32169
34	16-00001-001	Rom 1 P-Rom CC-1 2716	
35	16-00001-002	Rom 2 P-Rom CC-2 2716	
36	16-00001-003	Rom 3 P-Rom CC-3 2716	
37	16-00001-004	Rom 4 P-Rom CC-4 2716	
38	16-00001-005	Rom 5 P-Rom CC-5 2716	
39	16-00001-006	Rom 6 P-Rom CC-6 2716	
40	16-00001-014	Rom A P-Rom A 6331-1J	
41	16-00001-015	Rom B P-Rom B 6331-1J	
42	16-00001-016	Rom C P-Rom C 6331-1J	
43	12-10003-101	C1 Cap-Ceramic 100pf50V	AAT 41378
44	12-10002-104	C2 Cap-Ceramic 0.1uf50V	AAT 41672
45	11-00001-101	R 1 Res, Carbon 100ohm 1/4-5%	AAT 51741
46	11-00001-221	R 2 Res, Carbon 220 1/4-5%	AAT 51749
47	11-00001-331	R 3 Res, Carbon 330 1/4-5%	AAT 51753
48	11-00001-471	R 4 Res, Carbon 470 1/4-5%	AAT 51757
49	11-00001-102	R 5 Res, Carbon 1K	AAT 51765
50	11-00001-562	R 6 Res, Carbon 5.6K	AAT 51783
51	11-00001-103	R 7 Res, Carbon 10K 1/4-5%	AAT 51789
52	63-00014-001	Locking Circuit Board Support LCB-8	

CPU BOARD "B" & COMPONENT LIST

FIGURE 7

ITEM	TAITO PART NO.	DESCRIPTION	REFERENCE
1	79-00013-001	PC Board Sticker	
2	29-00008-001	Dip Switch DDS-8	AAO 52566
3	26-00001-024	IC Socket 24P	AAO 55787
4	26-00001-040	IC Socket 40P	AAO 55812
5	25-00004-001	PC Board Conn. PCN364J040AG	
6	25-00021-001	Angle Pin Header PS 50PA	AAO 55154
7	11-60001-202	Variable Res 2K P1	
8	13-00002-001	Diode IS1588	AAI 12025
9	15-50003-001	OP Amp MB 3712	AAT31042
10	15-20000-001	IC 1 LS IC 74LS00	AAT 33001
11	15-20002-001	IC 2 LS IC 74LS02	AAT 33003
12	15-20004-001	IC 3 LS IC 74LS04	AAT 33005
13	15-20008-001	IC 4 LS IC 74LS08	AAT 33009
14	15-20032-001	IC 5 LS IC 74LS32	AAT 33027
15	15-20042-001	IC 6 LS IC 74LS42	AAT 33032
16	15-20074-001	IC 7 LS IC 74LS74	AAT 33051
17	15-20125-001	IC 8 LS IC 74LS125	AAT 33089
18	15-20138-001	IC 9 LS IC 74LS138	AAT 33096
19	15-20139-001	IC10 LS IC 74LS139	AAT 33097
20	15-20157-001	IC11 LS IC 74LS157	AAT 33112
21	15-20161-001	IC12 LS IC 74LS161	AAT 33116
22	15-20174-001	IC13 LS IC 74LS174	AAT 33127
23	15-30259-001	IC14 TTL IC 74259	01709
24	15-20273-001	IC15 LS IC 74LS273	AAT 33170
25	15-20367-001	IC16 LS IC 74LS367	AAT 33203
26	15-20368-001	IC17 LS IC 74LS368	AAT 33204
27	15-20393-001	IC18 LS IC 74LS393	AAT 33220
28	15-10003-001	IC19 Static Ram MB8114NL	AAT 33156
29	15-50004-001	IC20 Op Amp LM3900	AAT 31011
30	15-60003-001	IC21 Sound IC AY-3-8910	AAT 32165

ITEM	TAITO PART NO.	DESCRIPTION	REFERENCE
31	16-00001-107	Rom 7 CC-7A 2732	
32	16-00001-108	Rom 8A P-Rom CC-8 2732	
33	16-00001-009	Rom 9 P-Rom CC-9 2732	
34	16-00001-010	Rom 10 P-Rom CC-10 2732	
35	16-00001-011	Rom 11 P-Rom CC-11 2732	
36	16-00001-012	Rom 12A P-Rom CC-12 2732	
37	16-00001-113	Rom 13A P-Rom CC-13 2732	
38	12-10002-102	C1 Cap-Ceramic 0.00uf50V	AAT 41399
39	12-10002-104	C2 Cap-Ceramic 0.1uf50V	AAT 41672
40	12-40001-105	C3 Cap., Tantalum 1uf25V	AAT 41425
41	12-40001-106	C4 Cap., Tantalum 10uf25V	AAT 41430
42	12-50001-476	C5 Cap., Tantalum 47uf35V	AAT 41657
43	12-20001-107	C6 Cap., Electrolytic 25VB 100uf	AAT 41036
44	12-20001-477	C7 Cap., Electrolytic 25VB 470uf	AAT 41039
45	11-00001-221	R 1 Res., Carbon 220ohm 1/4-5%	AAT 51749
46	11-00001-102	R 2 Res., Carbon 1K	AAT 51765
47	11-00001-103	R 3 Res., Carbon 10K	AAT 51789
48	11-00001-183	R 4 Res., Carbon 18K	AAT 51795
49	11-00001-273	R 5 Res., Carbon 27K	AAT 51799
50	11-00001-473	R 6 Res., Carbon 47K	AAT 51805
51	11-00001-104	R 7 Res., Carbon 100K	AAT 51803
52	11-00001-204	R 8 Res., Carbon 200K	AAT 51820
53	11-00001-394	R 9 Res., Carbon 390K	AAT 51827
54	11-00001-824	R10 Res., Carbon 820K	AAT 51835
55	11-50001-010	RB1 Resistor Block 1ohmx8	AAT 55036
56	15-00009-001	Custom Module	
57	15-44066-001	IC22 C Mos IC MC14066	AAT 36067
58	15-20245-001	IC23 LS IC 74LS245	AAT 33157

OPTION SWITCH & VOLUME CONTROL LOCATIONS

FIGURE 8

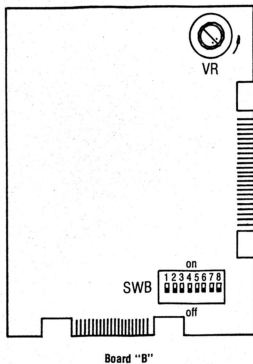

NOTES



5
1





TAITO AMERICA CORPORATION
1256 Estes Avenue, Elk Grove Village, IL 60007
Telephone (312) 981-1000 Telex 25-3290

PCB BOARD "A" SCHEMATIC

FIGURE 10

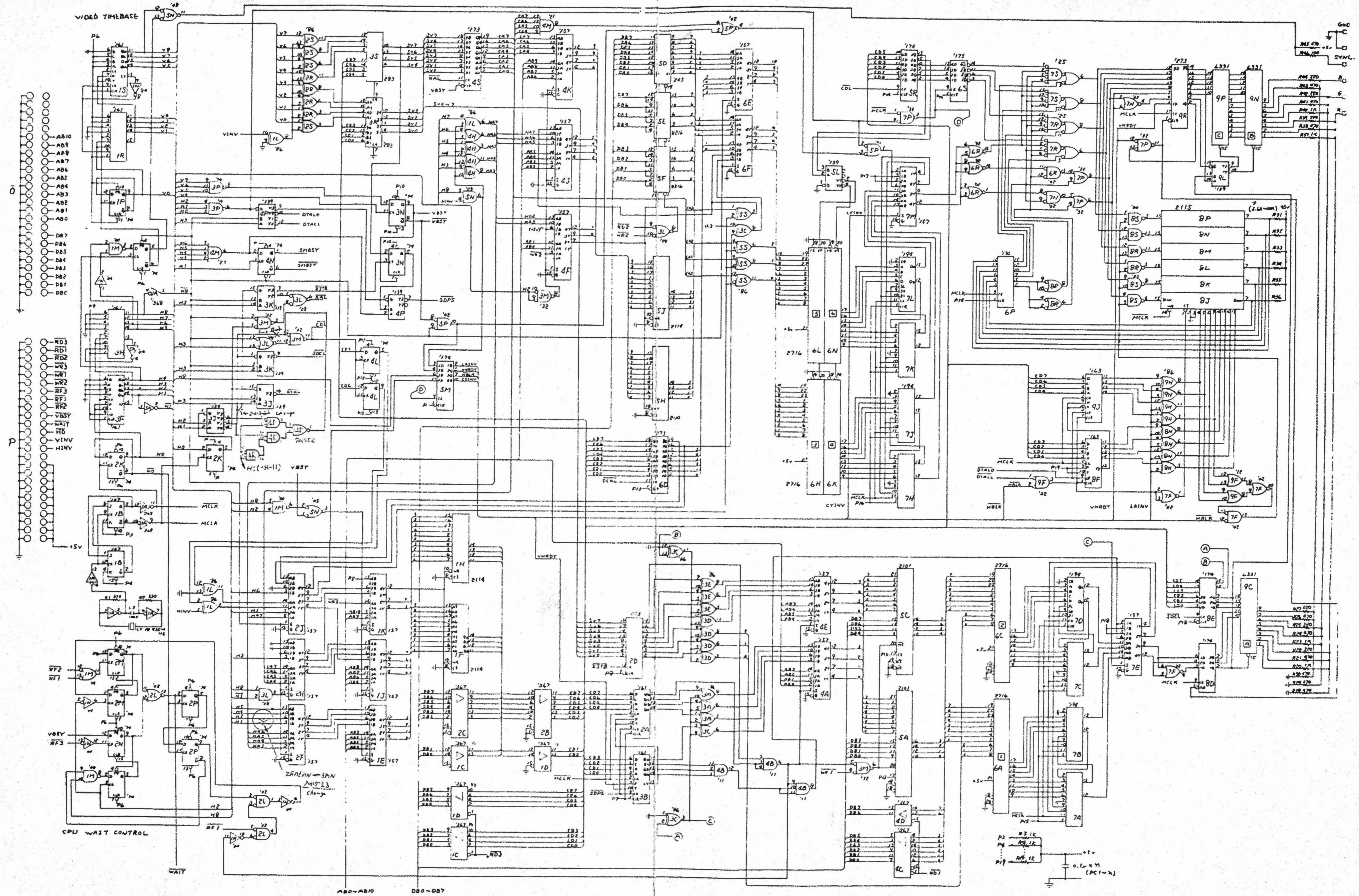

AB0-AB10 DB0-DB7

PCB BOARD "B" SCHEMATIC

FIGURE 11

