

2ND PRINTING NOV 99

# SEGA

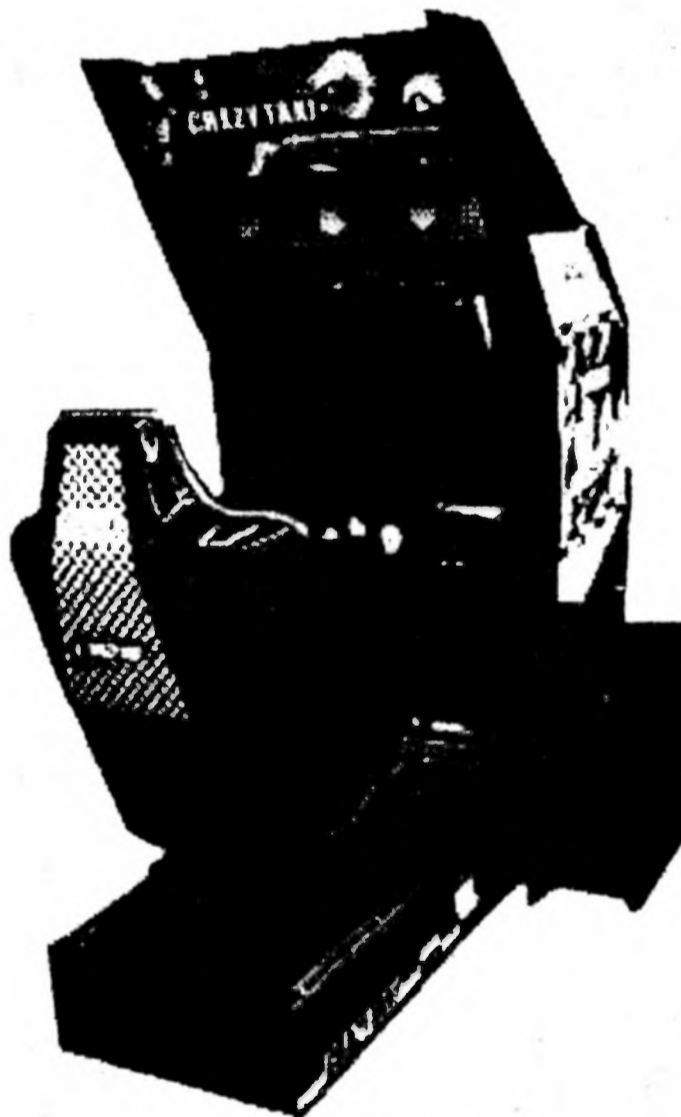

STD VERSION  
**OWNER'S MANUAL**



SEGA ENTERPRISES, INC. USA

MANUAL NO. 4201-6468-02



## **Warranty**

Your new Sega Product is covered for a period of 90 days from the date of shipment. This certifies that the Printed Circuit Boards, Power Supplies and Monitor are to be free of defects in workmanship or materials under normal operating conditions. This also certifies that all Interactive Control Assemblies are to be free from defects in workmanship and materials under normal operating conditions. No other product in this machine is hereby covered.

Sellers sole liability in the event a warranted part described above fails shall be, at its option, to replace or repair the defective part during the warranty period. For Warranty claims, contact your Sega Distributor.

Should the Seller determine, by inspection that the product was caused by Accident, Misuse, Neglect, Alteration, Improper Repair, Installation or Testing, the warranty offered will be null and void.

Under no circumstances is the Seller responsible for any loss of profits, loss of use, or other damages.

This shall be the exclusive written Warranty of the original purchaser expressed in lieu of all other warranties expressed or implied. Under no circumstance shall it extend beyond the period of time listed above.

## TABLE OF CONTENTS

INTRODUCTION OF THE OWNERS MANUAL	1
GENERAL PRECAUTIONS	2~3
1. PRECAUTIONS TO BE HEDED FOR OPERATION	4~5
2. NAME OF PARTS	6
3. ACCESSORIES	7~8
4. ASSEMBLY AND INSTALLATION	9~15
5. PRECAUTIONS TO BE HEDED WHEN MOVING MACHINE	16
6. CONTENTS OF GAME	17~19
7. EXPLANATION OF TEST AND DATA DISPLAY	20~30
7-1 SWITCH UNIT AND COIN METER	21
7-2 SYSTEM TEST MODE	22
7-3 GAME TEST MODE	22
7-4 INPUT TEST	23
7-5 OUTPUT TEST	23
7-6 SOUND TEST	24
7-7 C.R.T. TEST	24
7-8 VOLUME SETTING	25
7-9 GAME ASSIGNMENTS	26
7-10 COIN ASSIGNMENTS	27~29
7-11 BOOKKEEPING	30
7-12 BACKUP DATA CLEAR	30
8. HANDLE MECHA	31~33
8-1 REMOVING THE CONTROL PANEL	31
8-2 REPLACING AND ADJUSTING THE HANDLE'S VR	32
8-3 GREASING	33
9. SHIFT LEVER	34~35
9-1 REMOVING THE SHIFT LEVER	34
9-2 SWITCH REPLACEMENT	35
10. ACCEL & BRAKE	36~37
10-1 ADJUSTING AND REPLACING THE VR	36~37
10-2 GREASING TO FOOT BRAKE AND ACCEL	37
11. COIN SELECTOR	38~40
12. MONITOR	41~43
13. REPLACEMENT OF FLUORESCENT LAMP	44
13-1 REPLACEMENT OF FLUORESCENT LAMP	44
14. PERIODIC INSPECTION TABLE	45
15. TROUBLESHOOTING	46
16. GAME BOARD	47~49
16-1 REMOVING THE GAME BOARD	47
16-2 REPLACEMENT OF FUSE	48
16-3 COMPOSITION OF THE GAME BOARD	49
18. DESIGN RELATED PARTS	50
19. PARTS LIST	51~78
20. WIRING DIAGRAMS	XXX

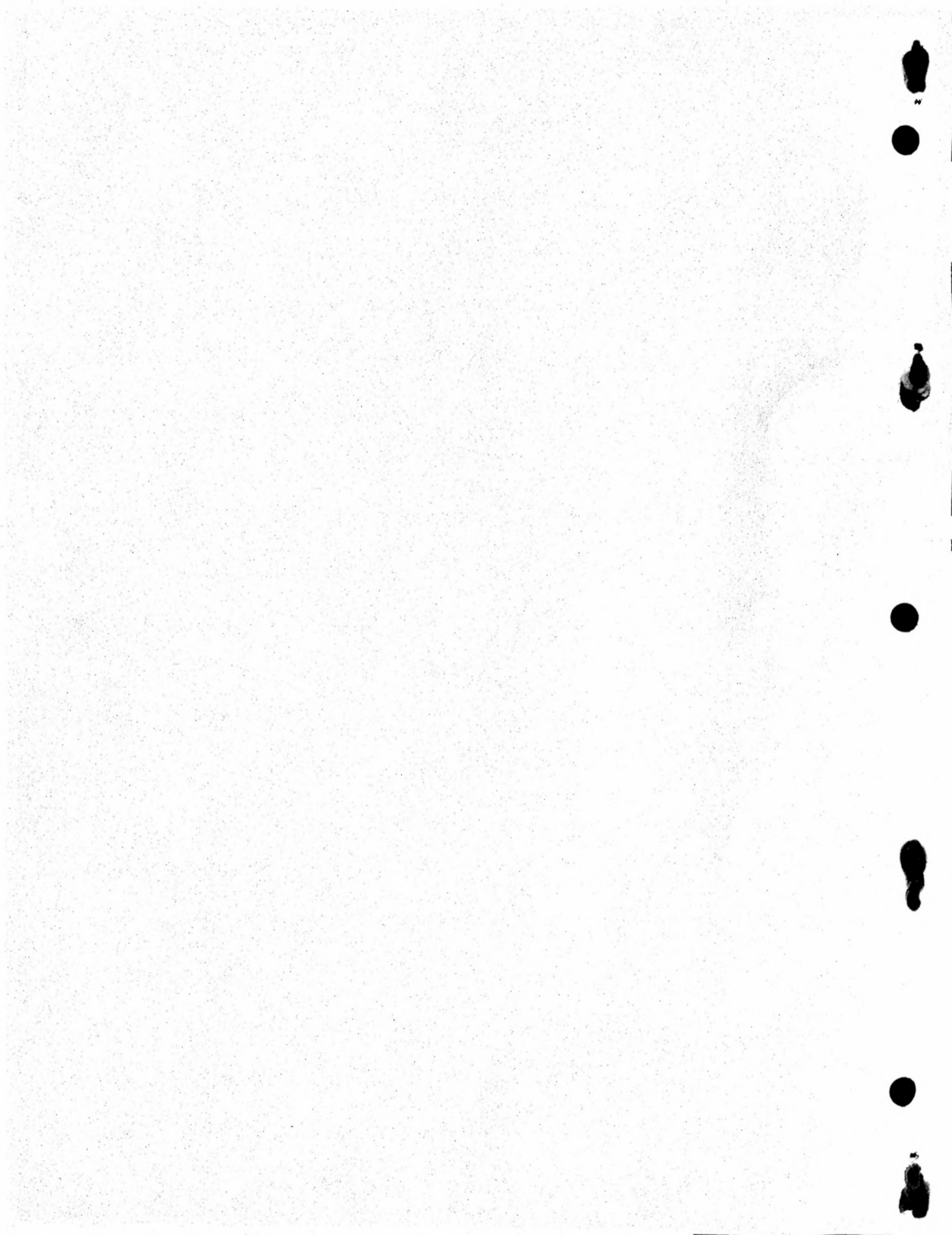

## SPECIFICATIONS

Installation space:	68 in. (L) x 41 in. (W)
Height:	84 in.
Weight:	Approx. 550 lbs.
Power maximum current:	3.5 Amp AC 120V 60 Hz
<b>MONITOR:</b>	<b>29" NANA0 MONITOR</b>

## INTRODUCTION OF THE OWNERS MANUAL

SEGA ENTERPRISES, LTD., has for more than 30 years been supplying various innovative and popular amusement products to the world market. This Owners Manual is intended to provide detailed descriptions together with all the necessary installation, game settings and parts ordering information related to CRAZY TAXI, a new SEGA product.

This manual is intended for those who have knowledge of electricity and technical expertise, especially in ICs, CRTs, microprocessors, and circuit boards. Read this manual carefully to acquire sufficient knowledge before working on the machine. Should there be a malfunction, non-technical personnel should under no circumstances touch the interior system. Should the need arise, contact our main office, or the closest branch office listed below.

### **SEGA ENTERPRISES, INC. (USA)**

#### **Customer Service**

45133 Industrial Drive

Fremont, CA 94538

Phone 650-632-7580

Fax 650-632-7594

7:30 am - 4:00 pm, Pacific Standard Time

Monday thru Friday

## **General Precautions**

---

**Follow Instructions:** All operating and use instructions should be followed.

**Attachments:** Do not use attachments not recommended by the product manufacturer as they may cause hazards.

**Accessories:** Do not place this product on an unstable cart, stand, tripod, bracket, or table. The product may fall, causing serious injury to a child or adult, and serious damage to the product. Use only with a cart, stand, tripod, bracket, or table recommended by the manufacturer, or sold with the product. Any mounting of the product should follow the manufacturer's instructions, and should use only mounting accessories recommended by the manufacturer.

**Moving the Product:** This product should be moved with care. Quick stops, excessive force, and uneven surfaces may cause the product to overturn.

**Ventilation:** Slots and openings in the cabinet are provided for ventilation, to ensure reliable operation of the product and to protect it from overheating; these openings must not be blocked or covered. The openings should never be blocked by placing the product in a built-in installation such as a bookcase or rack unless proper ventilation is provided or the manufacturer's instructions have been adhered to.

**Power Sources:** This product should be operated only from the type of power source indicated on the marking label. If you are not sure of the type of power supply to your location, consult your local power company. For products intended to operate from battery power or other sources, refer to the operating instructions.

**Grounding or Polarization:** This product is equipped with a three-wire grounding-type plug, a plug having a third (grounding) pin. This plug will only fit into a grounding-type power outlet. This is a safety feature. If you are unable to insert the plug into the outlet, contact your electrician to replace your obsolete outlet. Do not defeat the safety purpose of the grounding-type plug.

**Power Cord Protection:** Power-supply cords should be routed so that they are not likely to be walked on or pinched by items placed upon or against them, paying particular attention to cords at plugs, convenience receptacles, and the point where they exit from the product.

**Overloading:** Do not overload wall outlets, extension cords, or integral convenience receptacles as this can result in a risk of fire or electric shock.

**Object and Liquid Entry:** Never push objects of any kind into this product through openings as they may touch dangerous voltage points or short-out parts that could result in a fire or electric shock. Never spill liquid of any kind on the product.

**Servicing:** Do not attempt to service this product yourself as opening or removing covers may expose you to dangerous voltage or other hazards. Refer all servicing to qualified service personnel.

**Damage Requiring Service:** Unplug this product from the wall outlet and refer servicing to qualified service personnel under the following conditions:

- a) If the power cord or plug is damaged;
- b) If liquid has been spilled, or objects have fallen into the product;
- c) If the product has been exposed to rain or water;
- d) If the product does not operate normally when following the operating instructions. Adjust only those controls that are explained in the operating instructions. An improper adjustment of other controls may result in damage and will often require extensive work by a qualified technician to restore the product to its normal operation;
- e) If the product has been dropped or damaged in any way;
- f) When the product exhibits a distinct change in performance; this indicates a need for service.

**Replacement Parts:** When replacement parts are required, be sure the service technician has used replacement parts specified by the manufacturer or that have the same characteristics as the original part. Unauthorized substitutions may result in fire, electric shock, or other hazards.

**Safety Check:** Upon completion of any service or repairs to this product, ask the service technician to perform safety checks to determine that the product is in proper operating condition.

**Heat:** The product should be situated away from heat sources such as radiators, heat registers, stoves, or other products (including amplifiers) that produce heat.

**Lithium Battery-** Dispose of batteries only in accordance with the battery manufacturer's recommendations. Do not dispose in an open flame condition, since the battery may explode.

**Cleaning:** When cleaning the monitor glass, use water or glass cleaner and a soft cloth. Do not apply chemicals such as benzine, thinner, etc.

**Location:** This an indoor game machine, DO NOT install it outside. To ensure proper usage, avoid installing indoors in the places mentioned below:

- Places subject to rain/water leakage, or condensation due to humidity;
- In close proximity to a potential wet area;
- Locations receiving direct sunlight;
- Places close to heating units or hot air;
- In the vicinity of highly inflammable/volatile chemicals or hazardous matter;
- On sloped surfaces;
- In the vicinity of emergency response facilities such as fire exits and fire extinguishers;
- Places subject to any type of violent impact;
- Dusty places.

#### **INSTALLATION PRECAUTIONS**

- Verify the amperage of the branch circuit outlet before plugging in the power plug. Do not overload the circuit.
- Avoid using an extension cord. If one is required, use an extension cord of type SJT, 16/3 AWG rated min. 120 VAC, 7A.
- Moving this unit requires a minimum clearance (of doors, etc.) of 32" (W) by 77" (H).
- For the operation of this machine, secure a minimum area of 32" (W) by 42"(D).

#### **REGULATORY APPROVALS**

This game has been tested and found to comply with the Federal Communications Commission Rules.

This device complies with Part 15 of the FCC Rules. Operation is subject to the following two conditions: (1) This device may not cause harmful interference, and (2) this device must accept any interference received, including interference that may cause undesired operation.

This game has been tested and listed by Underwriters Laboratories, Inc., to ANSI/UL22.

**LISTED**



**5K92**

**AMUSEMENT MACHINE**

# 1 . PRECAUTIONS TO BE HEDED FOR OPERATION

In order to prevent accidents, be sure to comply with the following points before and during operation.

## PRECAUTIONS TO BE HEDED FOR OPERATION BEFORE STARTING THE OPERATION



- In order to avoid accidents, check the following before starting the operation:  
Check if all of the adjusters are in contact with the surface. If they are not, the cabinet can move and cause an accident.

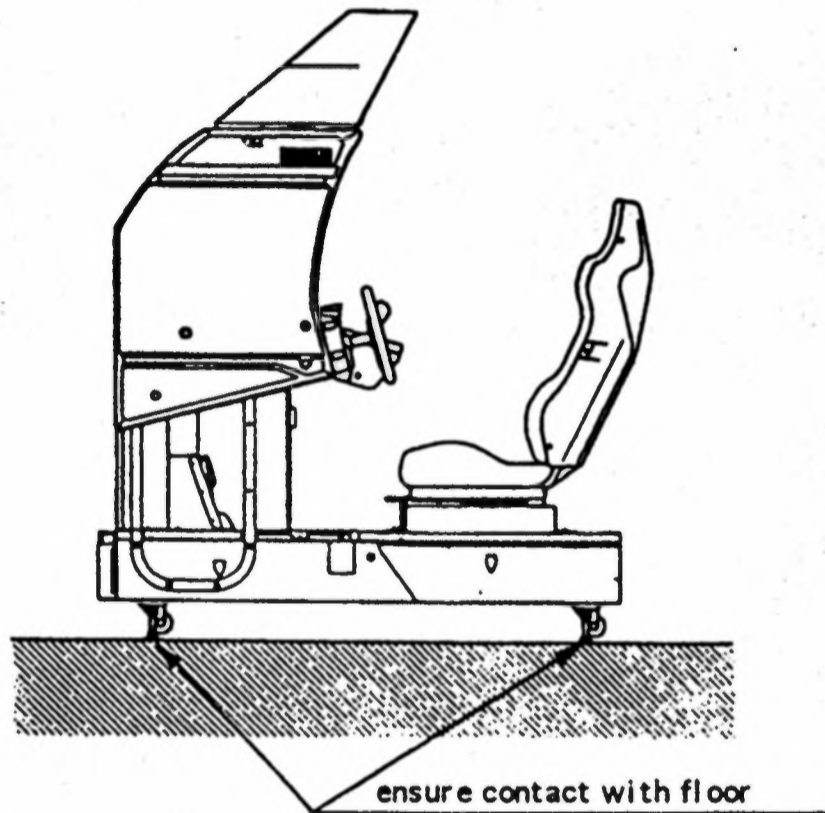

- Do not climb on the product. Climbing on the product can cause falling down accidents. To check the top portion of the product, use a step.
- To avoid electric shock, check to see if door & cover parts are closed.
- To avoid electric shock, short circuit and or parts damage, do not put the following items on or in the periphery of the product:
  - Flower vases, flower pots, cups, water tanks, cosmetics, and receptacles/containers/vessels containing chemicals and water.



To avoid injury, be sure to provide sufficient space by considering the potentially crowded situation at the installation location. Insufficient installation space can cause the player to come into contact with or hit others and result in injury or trouble.

## PRECAUTIONS TO BE HEEDED DURING OPERATION



**CAUTION!**

To avoid injury and accidents, those who fall under the following categories are not allowed to play the game:

- \* Intoxicated persons
- \* Those who have high blood pressure or heart problems.
- \* Those who have experienced muscle convulsion or loss of consciousness when playing video games, etc.
- \* Persons susceptible to motion sickness.
- \* Persons whose acts runs counter to the products warning displays.
- \* Instruct those who wear high-heeled shoes to refrain from playing the game by explaining that playing the game with high-heeled shoes is very dangerous and likely to cause a potentially hazardous situation.



**CAUTION!**

- To avoid electric shock and short circuit, do not allow customers to put hands and fingers or extraneous matter in openings of the product or small openings in or around doors.
- To avoid electric shock and short circuit, do not allow the customers to unplug the power plug without a justifiable reason.
- Although this product has the accident preventive covering attached to potentially hazardous places where hand and fingers could be caught, small children are unable to perceive hazards. Use care so that small children do not come close to the product when in play.
- Immediately stop such violent acts as hitting and kicking the product. Such violent acts can cause parts damage and/or falling down, resulting in injury due to fragments and falling down.

## 2 . NAME OF PARTS

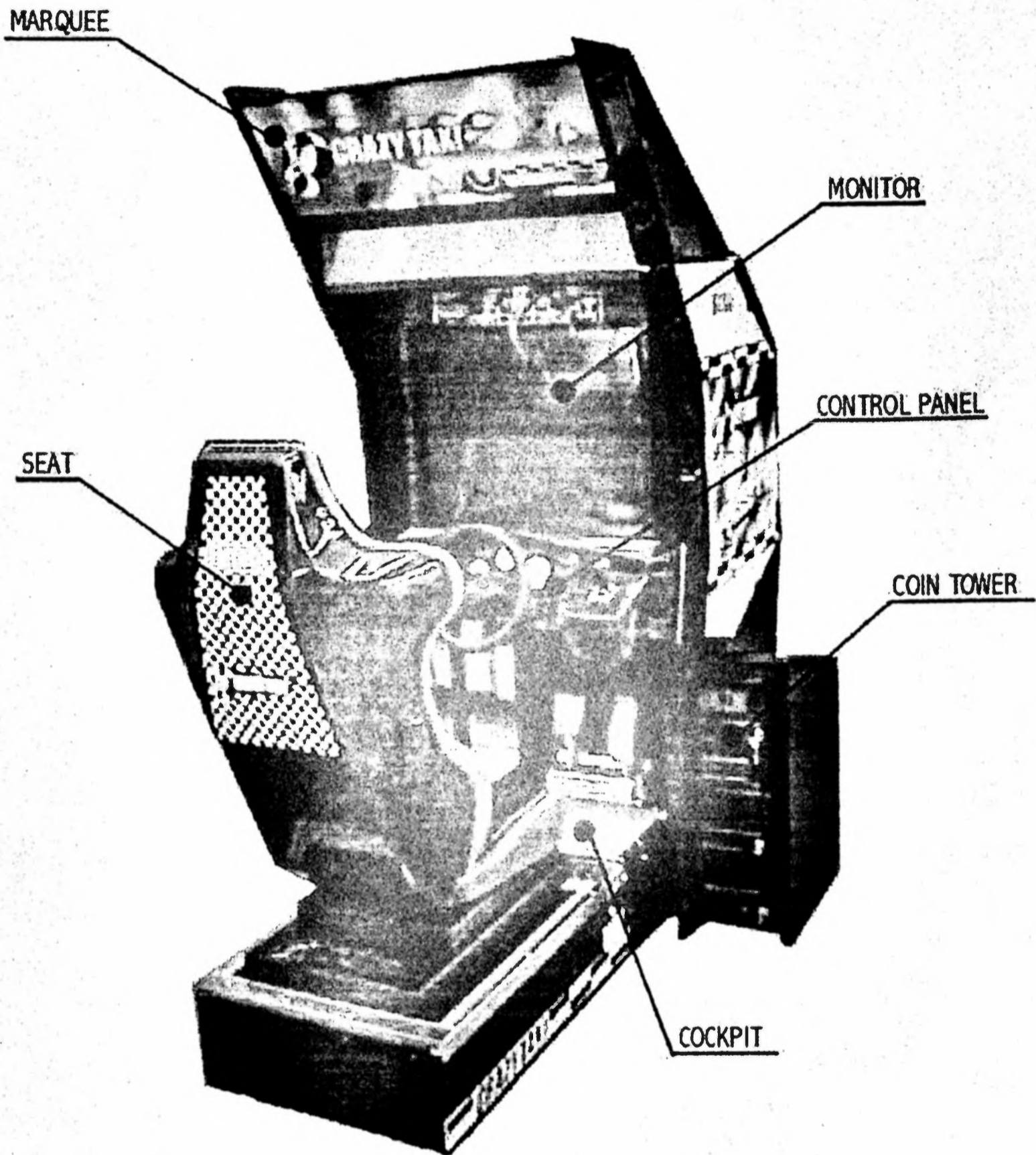

GAME SPECIFICATIONS	WIDTH in.	LENGTH in.	HEIGHT in.	WEIGHT lbs.
All measurements are and rounded UP				
DURING SHIPPING	45"	X 70"	X 84"	~ 600 LBS.
WHEN ASSEMBLED	39"	X 65"	X 80"	550 LBS.

### 3. ACCESSORIES

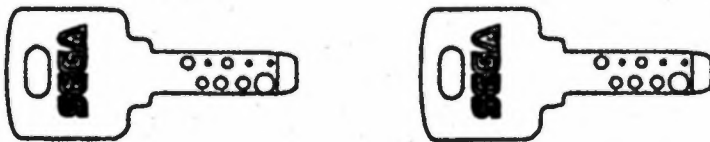
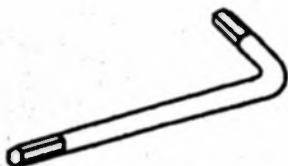
<p><b>DESCRIPTION</b>      <b>OWNERS MANUAL</b> Part No. (Qty.) 4201-6468-01 Note Figures If Part No. has no description, the Number has not been registered or can not be registered. Such a part may not be obtainable even if the customer desires to purchase it. Therefore, ensure that the part is in safekeeping with you.</p>	<p><b>KEY MASTER</b> 220-5576 (2) For opening/closing the doors</p>	<p><b>KEY</b> (2) For the CASHBOX DOOR</p>
<p><b>TAMPERPROOF WRENCH</b> M8 540-0009-01 (1) TOOL</p>	 The image shows two keys side-by-side. The left key is a 'KEY MASTER' with a notched head and a bit with four circular indentations. The right key is a 'KEY' for the 'CASHBOX DOOR', also with a notched head and a bit with four circular indentations.	
 A simple line drawing of a tamperproof wrench, which is a long, thin metal rod with a hook-shaped end.		



WARNING!

**THE SHIPMENT METHOD DESCRIBED BELOW ONLY APPLIES TO 'MODEL 3' BOARDS CONTAINED IN THE FOLLOWING GAMES:**

LOST WORLD, VIRTUA FIGHTER 3, SUPER GT, SEGA BASS FISHING, STRIKER 2, HARLEY DAVIDSON, RALLY 2, DAYTONA 2, DIRT DEVILS, HOUSE OF THE DEAD 2, OCEAN HUNTER, STAR WARS TRILOGY, ZOMBIE REVENGE, CRAZY TAXI

**!!NEVER SHIP MODEL 3 / NAOMI GAME BOARDS OUTSIDE OF CAGE!!**

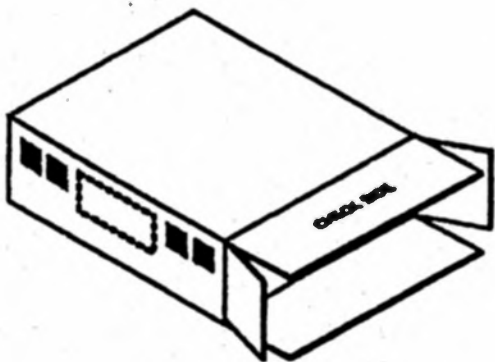

CARTON BOX

601-8928 (1)

Used for transporting the GAME BOARD.  
{SUPPLIED WITH YOUR GAME}

**DO NOT SHIP GAME BOARD WITHOUT THIS BOX AS IT MAY DAMAGE THE GAME BOARD AND VOID YOUR WARRANTY.**

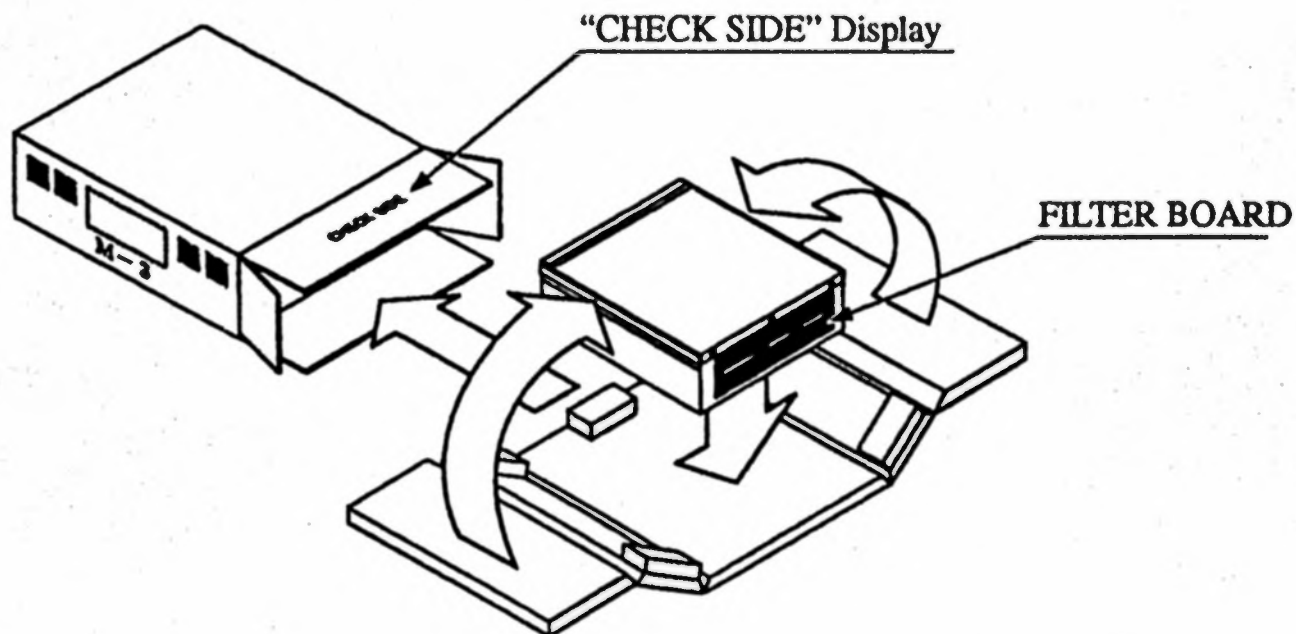

WARNING!

**NO OTHER GAMES BOARDS ARE TO BE SHIPPED IN THE CAGE AS THEY MAY BE DAMAGED BEYOND REPAIR. PLEASE SHIP THEM WITHOUT CAGE PROPERLY PROTECTED DURING SHIPPING.**

## 4 . ASSEMBLING AND INSTALLATION



Assembling should be performed as per this manual. Since this is a complex machine, erroneous assembling may cause damage to the machine, or malfunctioning to occur.

When assembling, be sure to perform work by plural persons. Depending on the assembly work, there are some cases in which performing the work by a single person can cause personal injury or parts damage.

When carrying out the assembly work, follow the procedure in the following 5-item sequence:

- 1 ASSY OF THE REAR CABI (COCKPIT)
- 2 ASSY OF BILLBOARD
- 3 SECURING IN PLACE (ADJUSTER ADJUSTMENT)
- 4 POWER SUPPLY
- 5 ASSEMBLING CHECK

Note that the tools such as a phillips screwdriver and wrench for M16 hexagon bolt w/24 mm width across flats are required for the assembly wor.

- 1 ASSY OF REAR CABI (COCKPIT)



Permanantly tightening the hex bolts should not be completed until the leg levelers are adjusted properly.

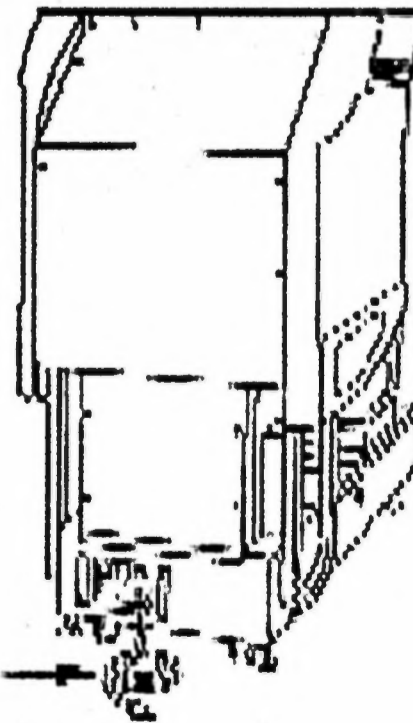

- ① Install the coin chute tower on the Right-hand side of cabinet. Open the coin chute door and the cashbox door to secure with the 4 hexagon bolts from inside the doors. Please note that the Coin Chute tower is NOT mounted

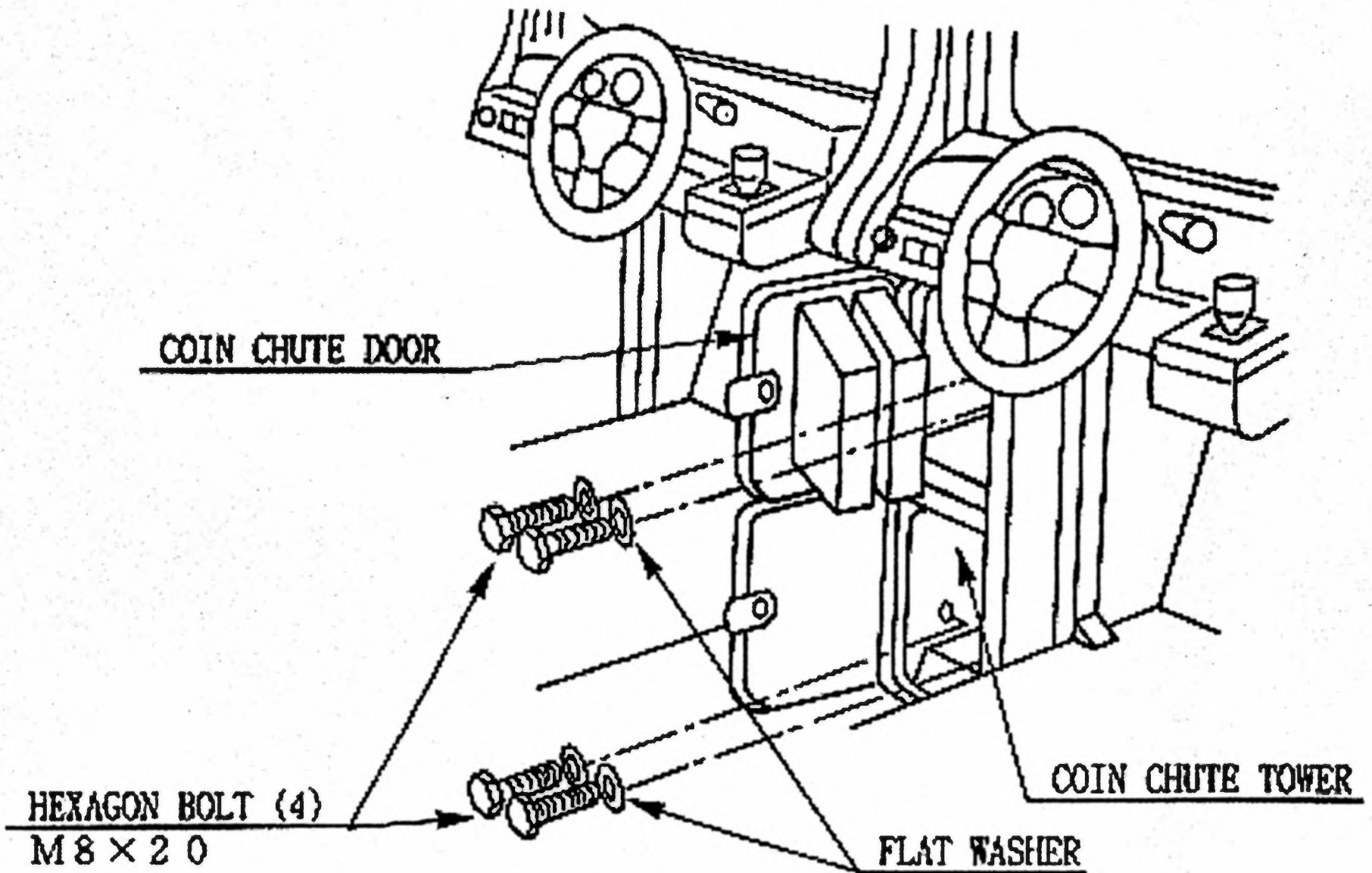

*NOTE: ON SEGA'S CRAZY TAXI GAME THERE IS NOT TWO COCKPITS SIDE BY SIDE AS PICTURED ABOVE. THE GAME HAS ONLY ONE COCKPIT AND THE COIN TOWER WILL MOUNT ON THE RIGHT SIDE AS YOU FACE THE CABINET..*

## 2 ASSY OF THE BILLBOARD



Due to its large size, it is very difficult for one person alone to install the billboard, Make sure 2 or more persons are available to perform this work. Attempting to perform the installation alone can cause an accident.

- ① Mount Billboard on cabinet by ensuring the front lip of the Billboard is securely placed under the mounting bracket already installed on the cabinet. Fasten with the 3 hexagon bolts.
- ② Connect all of the 4 connectors inside the Billboard box (This needs to be done prior to final installation of Billboard Assy).

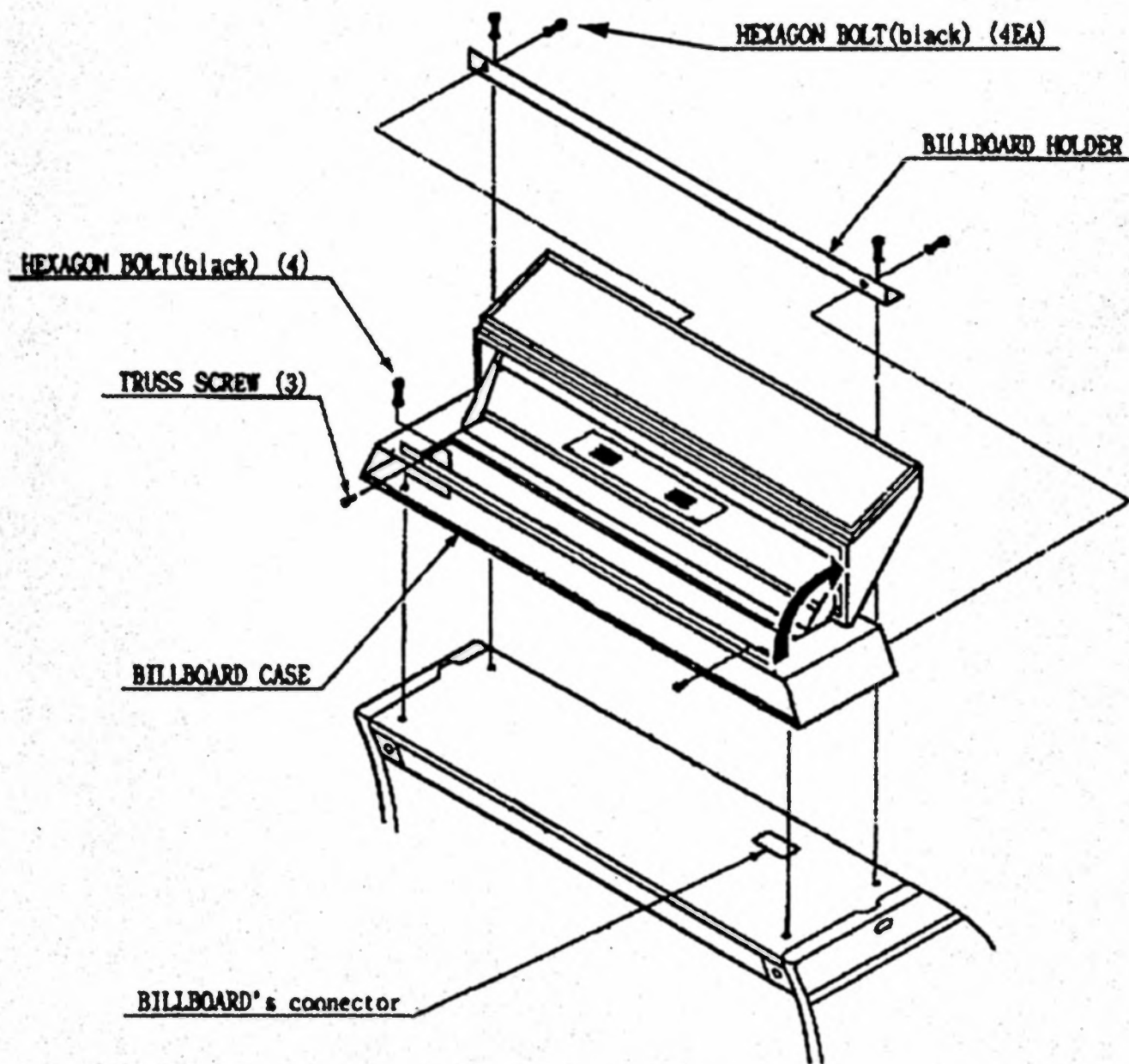

## 2

### SECURING IN PLACE (ADJUSTER ADJUSTMENT)



Be sure to have all the Adjusters make contact with the surface. Unless the Adjusters come into contact with the surface, the Cabinet can move of itself, causing an accident.

This machine has 4 each of casters and adjusters (shown below). When the installation position is determined, cause the adjusters to come into contact with the floor directly, make adjustments in a manner so that the casters will be raised approximately 5mm. from the floor and make sure that the machine position is level.

- ① Move the machine to the installation position.
- ② Cause all of the leg levelers to make contact with the floor. By using a wrench, make adjustments in the height of the leg adjusters to ensure that the machine's position is level.
- ③ After making adjustments, fasten the leg adjuster nut upward and secure the height of the leg adjuster.

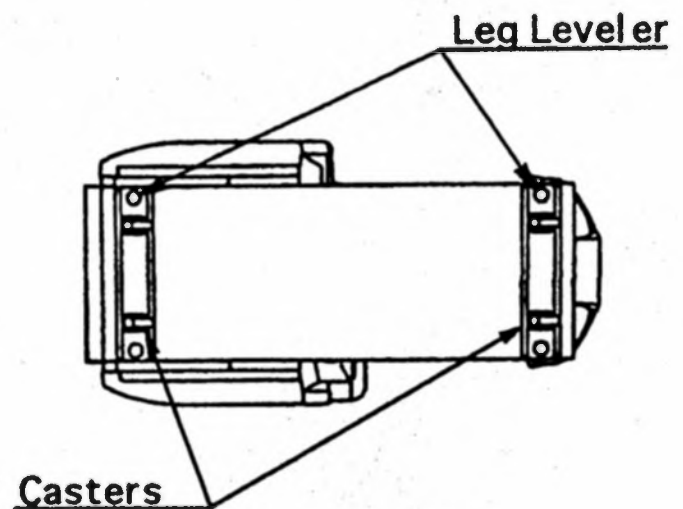
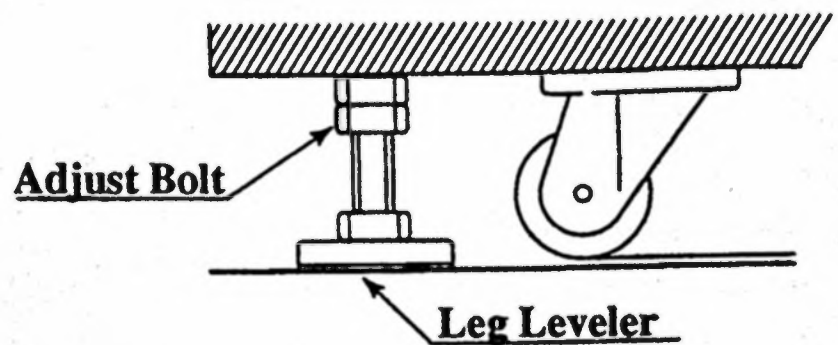

# 4

## POWER SUPPLY



- Ensure that the power cord is not exposed on the surface (passage, etc.). If exposed, they can be caught and are susceptible to damage. If damaged, the cord can cause an electric shock or short circuit.
- Ensure that the wiring position is not in the customer's passage way or the wiring has protective covering.

Connect the game to the power supply and turn on power to the game. Before connecting power supply be sure that power switch is off

- ① Turning the AC unit's main switch on will cause the machine to start the power check and network check automatically.
- ② In the Power On check, the steering wheel turns left and right, and then returns to the centering position and stops. In this check, the values of the VR inside the control panel are corrected.
- ③ Until this check is finished, and the steering wheel stops, do not touch the steering wheel or play the game.

If you do, the steering reaction during the game (reaction at the time of course-out or crash) can not be obtained correctly. In the case of an abnormal reaction during the game, turn power on again from the beginning and complete the power on check.

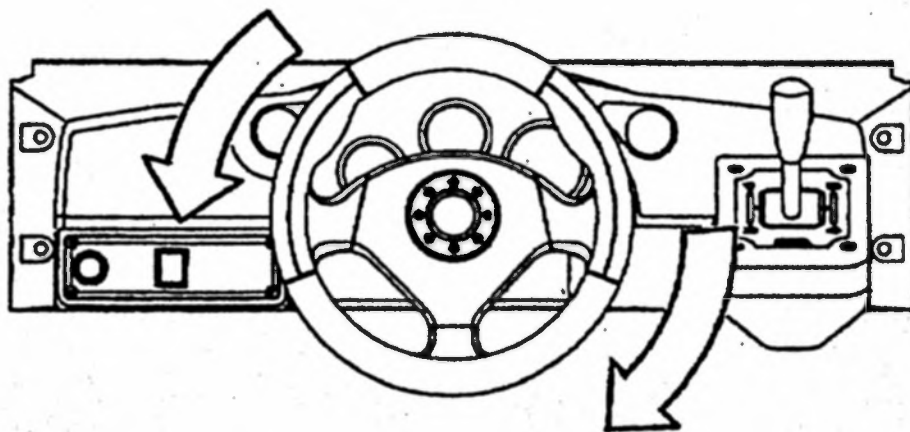
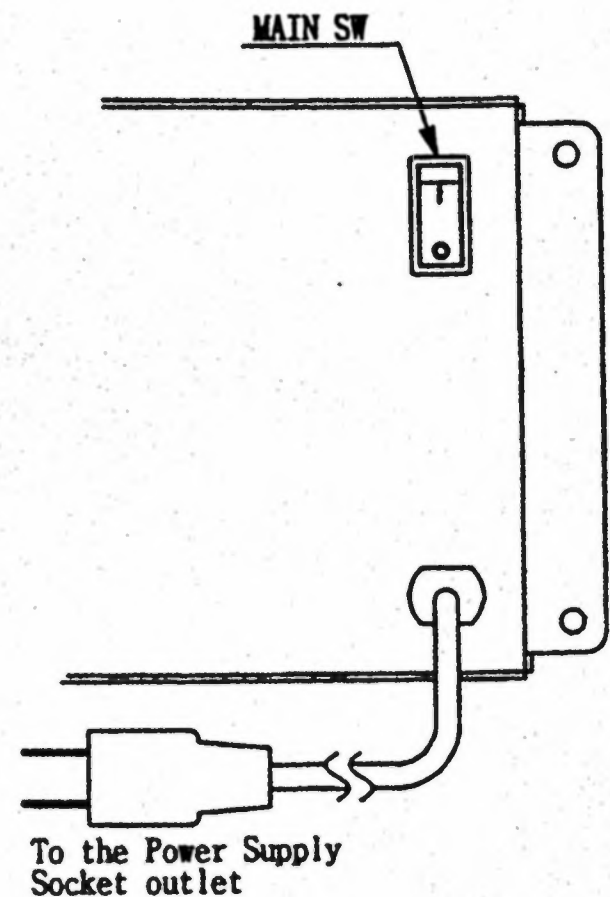

# 5

## ASSEMBLING CHECK

The TEST MENU allows for each part of the cabinet to be checked, the Monitor to be adjusted, and the coin and game related various functions to be performed.

Selecting the MEMORY TEST on the test mode menu screen causes the on-board memory to be tested automatically. The game board is satisfactory if the display beside each IC No. shows GOOD.

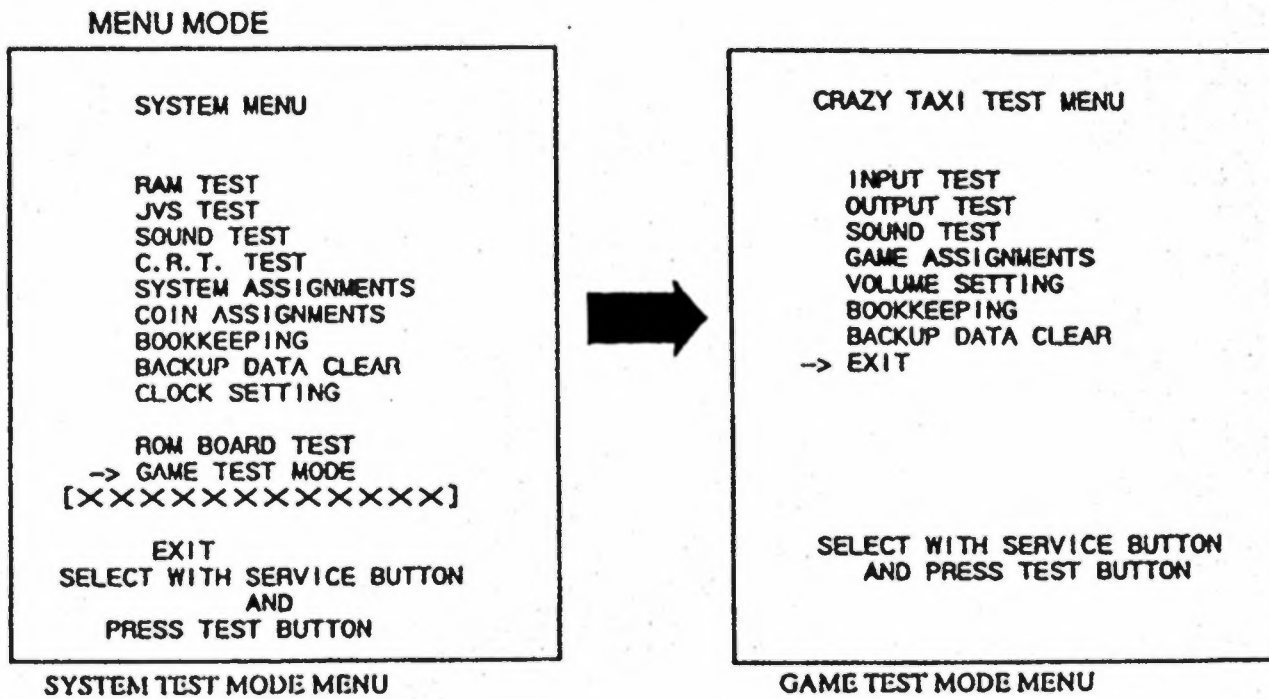

INPUT TEST

DRIVE GEAR	OFF
REVERSE GEAR	OFF
START	OFF
COIN CHUTE #1	OFF
COIN CHUTE #2	OFF
SERVICE	OFF
TEST	OFF
HANDLE	80H
ACCEL	30H
BRAKE	30H

PRESS TEST AND SERVICE BUTTON TO EXIT

Selecting the INPUT TEST on the Test Mode menu screen causes the screen (on Which each switch and V.R. are tested) to be displayed. Press each switch. For the coin switch test, insert a coin from the coin inlet with the coin chute door being open. If the display beside each switch indicates "ON", the switch and wiring connections are satisfactory. Check the display of V.R. value for steering wheel and accelerator & brake. If the V.R. values are not satisfactory, make adjustments as necessary.

OUTPUT TEST

START LAMP    ON

  
  
  
  
  
  
  
  
  
  

PRESS TEST BUTTON TO EXIT

In the OUTPUT TEST mode, carry out lamp test to ensure that each lamp lights up satisfactory.

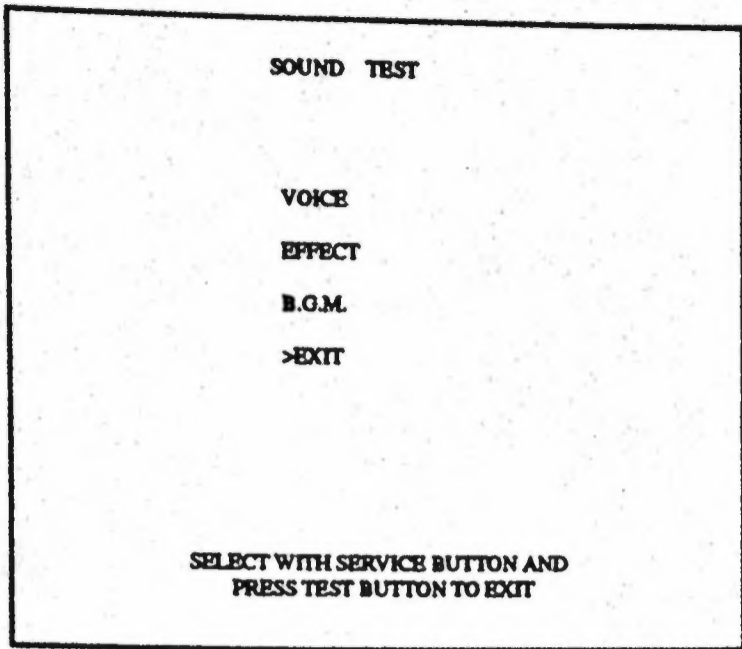

In the TEST mode, selecting SOUND TEST causes the screen, on which sound related BD and wiring connections are tested, to be displayed. Be sure to check if the sound is satisfactorily emitted from each of speaker and the sound volume is appropriate.

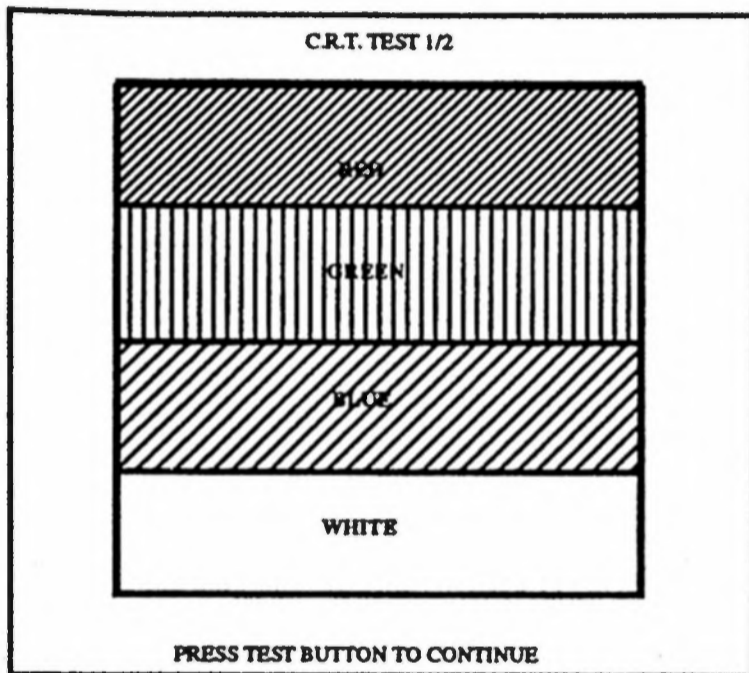

In the TEST mode menu, selecting C.R.T. TEST allows the screen (on which the projector is tested) to be displayed. Although the projector adjustments have been made at the same time of shipment from the factory, color deviation, etc., may occur due to the effect caused by geomagnetism, the location building's steel frames and other game machines in the periphery. By watching the test mode screen, make judgement as to whether an adjustment is needed. If it is necessary, adjust the projector by referring to Section 9.

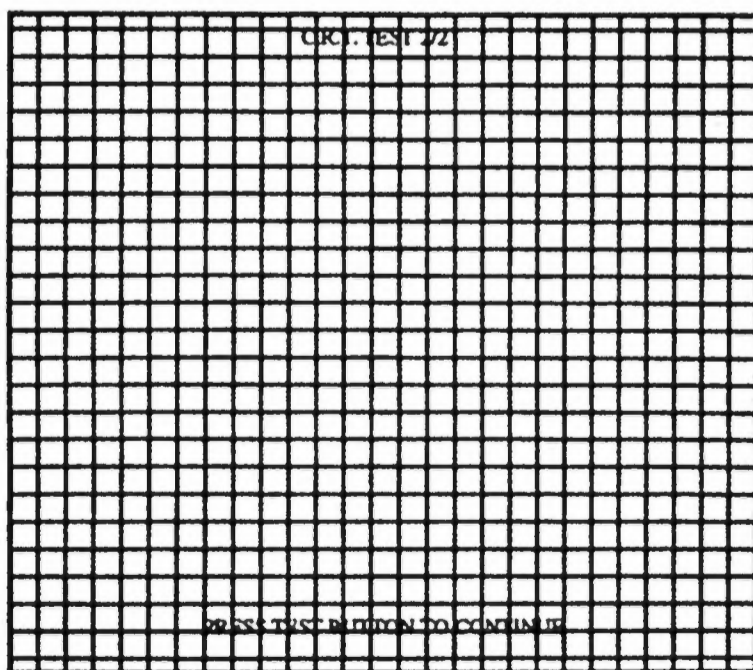

Perform the above inspections also at the time of monthly inspection.

## 5 . PRECATIONS TO BE HEEDED WHEN MOVING THE MACHINE



- When moving the machine, be sure to pull out the plug from the power supply. Moving the machine with the plug as is inserted can damage the power cord and cause a fire or electric shock.
- When moving the machine on the floor, retract the Adjusters and ensure that Casters make contact with the floor. During transportation, pay careful attention so that Casters do not tread power cords. Damaging the power cords can cause an electric shock and/or short circuit.
- When lifting the cabinet, be sure to hold the catch portions or bottom part. Lifting the cabinet by holding other portions can damage parts and installation portions, due to the empty weight of the cabinet, and cause personal injury.



Use care when handling glass made parts. When the glass is damaged, fragments of glass can cause injury

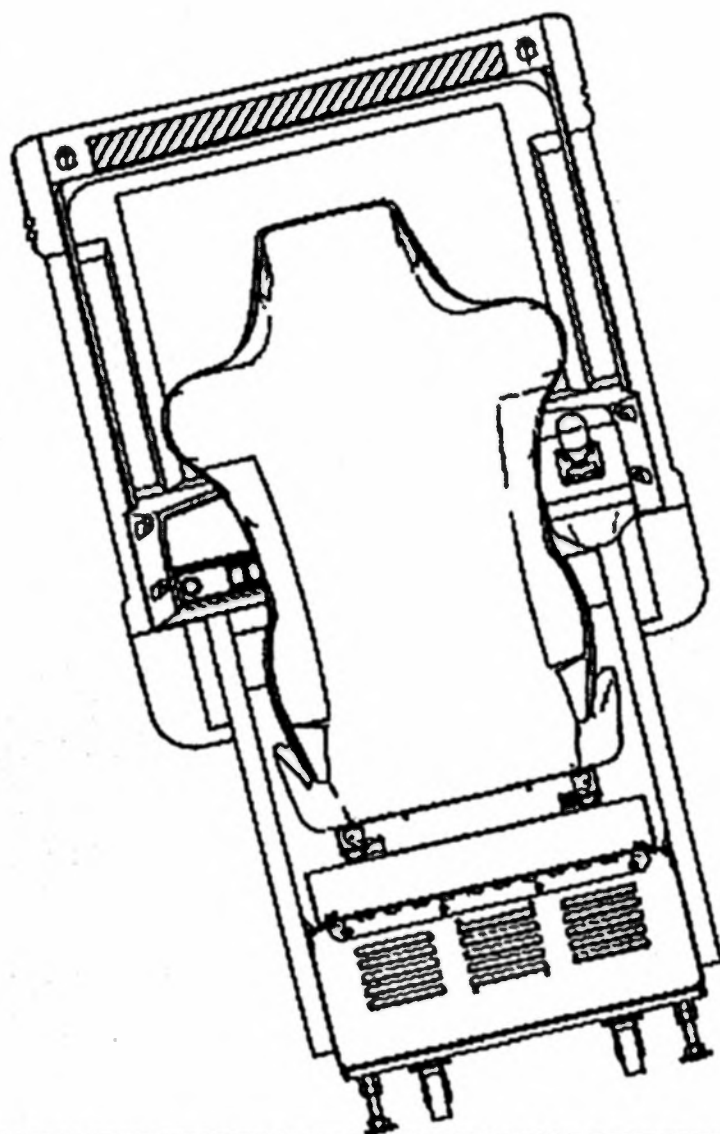

Do not push the cabinet from the left/right direction.

## 6. CONTENTS OF GAME

The following explanations apply to the case the product is functioning satisfactorily. Should there be any moves different from the following contents, some sort of faults may have occurred. Immediately look into the cause of the fault and eliminate the cause thereof to ensure satisfactory operation. During the Advertise mode, the Billboard's Decoration Lamp lights up periodically. When the machine is energized, the Billboard's Fluorescent Lamp is always lit. The Steering Wheel repeats centering action periodically. Automatic centering will apply to the Steering Wheel if it is not centered. During the Advertise Mode, sound is emitted from the Speaker beside the Monitor.

### OUTLINE OF GAME

The Player as a taxi driver picks up a passenger (hereafter customer) randomly appearing on the the Game Field waiting for a taxi, and takes the Customer tot he desired destination. Time Limit is set for each Customer (displayed on the upper left-hand side of Customer while traveling). If the taxi takes Customer to the destination within the time limit, Customer pays the fare (the player earns points.).

On the contrary, if the player fails to take the Customer to the destination within the time limit, Customer will get off and results in no fare (no points) for the player. The Player is to accomplish the above within the time limit of the game (displayed on the upper left-hand side of the screen) repetitively as many times as possible. When time limit becomes zero (0), the game is over. The game is aimed at earning money as much as possible by taking as many Customers as possible to their destinations within the time limit.

### HOW TO OPERATE

The operation of Steering Wheel, and Accelerator & Brake pedals are similiar to an actual car.

#### SHIFT LEVER

Input to (D) towards the monitor side to drive forward, and to (R) towards you to reverse. Auto transmission and not manual is applied to speed shifting. The DR LAMP displays Forward (D) and Reverse (R), whichever is being inputted.

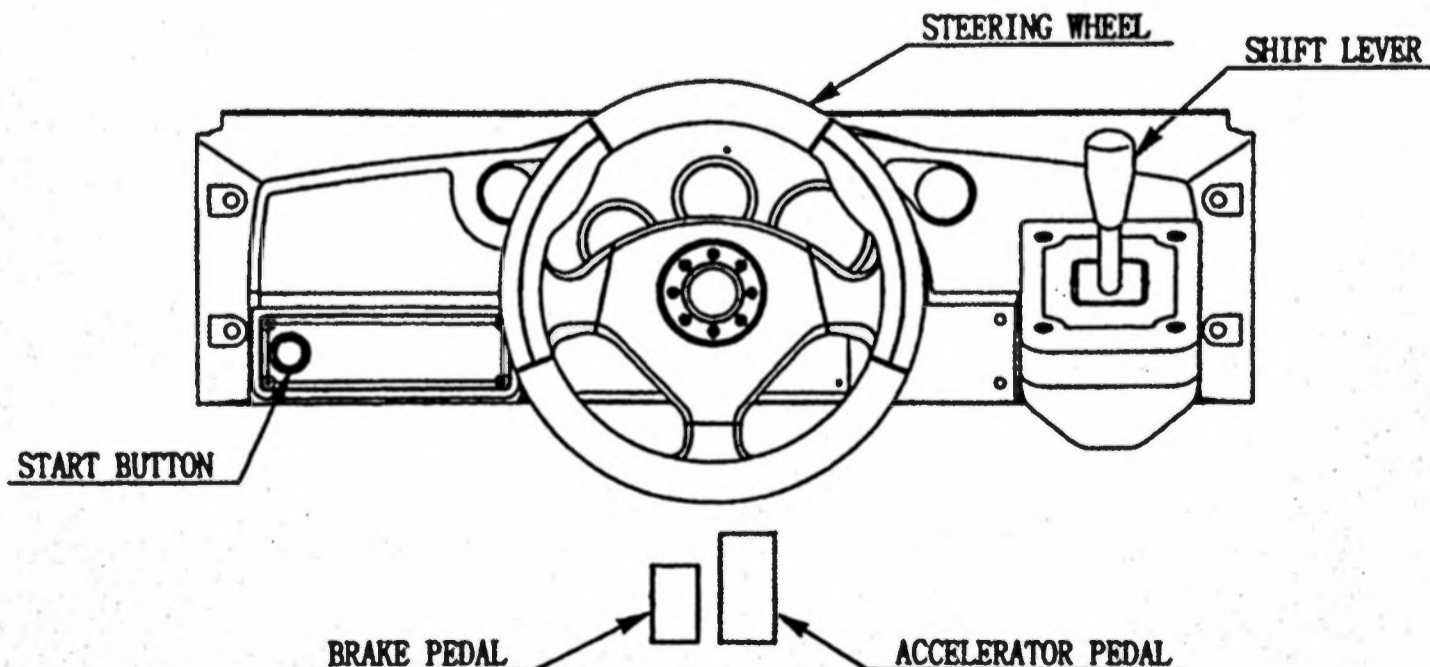

## HOW TO PLAY

- ① Insert a coin.  
Coin insertion causes credit(s) to be displayed on the screen. For example, in the case of 2 coins one credit setting, "INSERT COIN(S) CREDIT(S) 1/2" is displayed when one coin is inserted.
- ② Inserting one play worth of coin(s) causes "PRESS START BUTTON" to be displayed and the START BUTTON to flash. Press the START BUTTON to have the character mode appear on this screen.
- ③ In the Character Select Mode, select on-screen player character. Turn the Steering Wheel left or right to shift to each character select mode. Press the START button or step on either of Accel. or Brake pedal to decide on the character being displayed.
- ④ While the Character Select Mode is displayed, countdown is executed. Counting down to (0) causes the character being displayed to be selected automatically.

- ⑤ When the character is determined, the game starts. The Taxi picks up the Customer who has the \$ Mark above him/her. There is a circular mark signifying the Stop Area in the periphery of Customer. Stop the taxi in the Stop Area.

When the taxi completely stops in the Stop Area, the on-screen scene shifts and Customer rides in automatically. At this time, the taxi is in status not operable.

When the Customer rides in, the necessary time to the destination is added to the Game's Time Limit.

The color of the \$ mark represents the distance of the destination. Green indicates the furthest destination. The distance becomes shorter sequentially in order of green-->yellowish green-->yellow-->orange-->red.



- ⑥ Take the Customer to the destination. While traveling to the destination, time limit and the arrow showing the direction of destination are displayed on the screen.

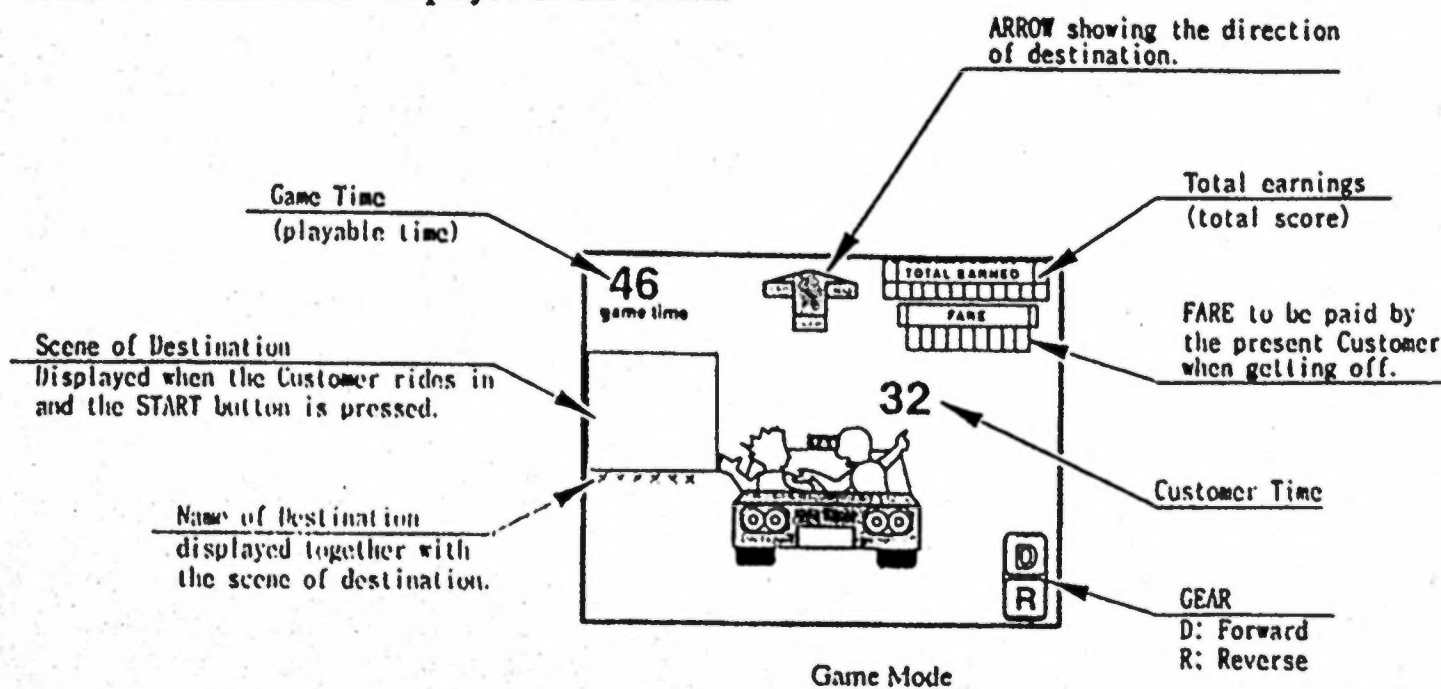

⑥ The following explains as regards how to earn FARE (or score points).

The minimum fare is earned at the time the taxi picks up the Customer.

Basically, the best way to earn FARE is to take the Customer to their destination as fast as possible. In other words, since the time remaining when reaching the destination is converted into FARE, the more remaining time is, the greater the FARE the player earns.

In addition to the above, receiving a tip is another way of increasing the FARE. The tip awarded for doing something to please the customer is added to the FARE. Details are as follows:

- Tip for dodging: Awarded when dodging other (ordinary) car at the very critical moment.
- Tip for Jumping: Awarded when the taxi jumps over trailers, etc.
- Tips for drifting: Awarded when the taxi drifts.

When awarding tips, coins are sent in a flying motion from the Customer towards the FARE METER. If tips are consecutively earned, the earning rate increases (in combo) This combo effect resets if the taxi bumps against another ordinary car.

The combo display appears below the FARE METER.

The Customer's fare is not added to the TOTAL FARE unless the Customer is taken to the destination.

⑦ When reaching the destination, drop off the Customer. Stop the taxi within the destination area mark. When the taxi completely stops within the area, the on-screen shifts to evaluation mode and the customer gets off automatically. the Customer's evaluation displayed in characters depends on the remaining seconds of the Customer time when reaching the destination.

- SPEEDY: Display of more remaining time/money converted from time is paid.
- NORMAL: Display of normal remaining time/normal amount of money converted from time paid.
- SLOW: Display of less remaining time/less amount of money converted from time is paid.

After suming up the above, the Customer's FARE is determined and then the FARE is added to the TOTAL FARE. After TOTAL FARE calculations, the player ranking is displayed. The ranking is based on the score data of the 99 players played in the past.

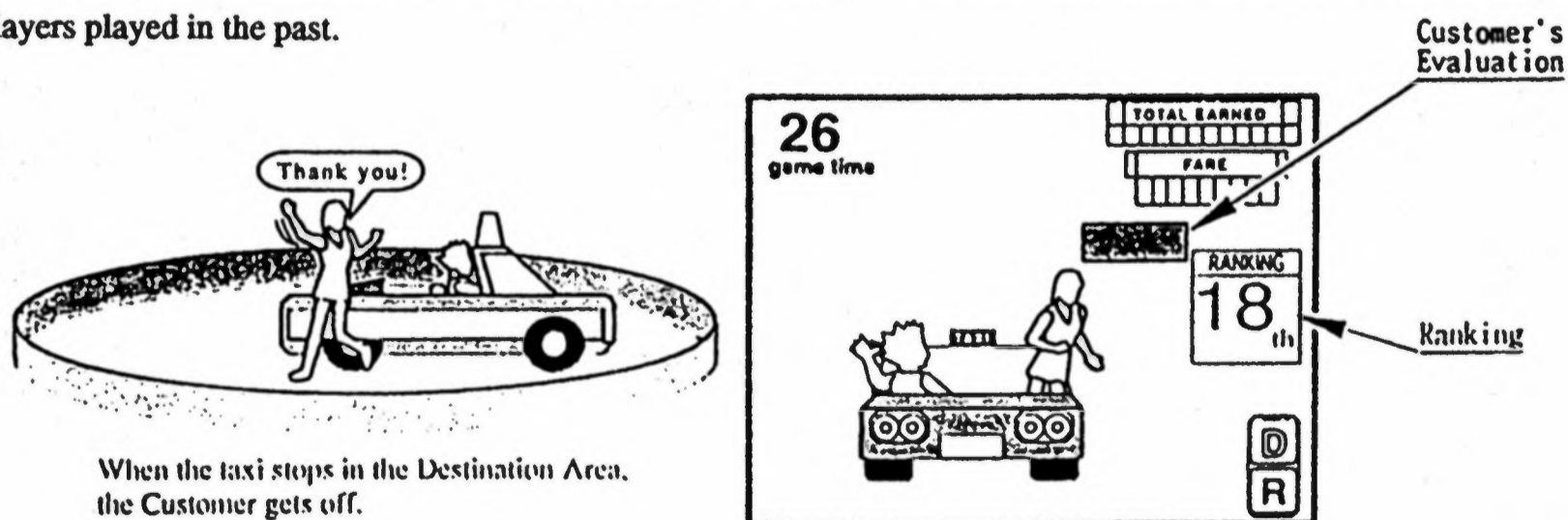

⑧ If the remaining time of the Customer becomes zero, the Customer becomes angry and gets off. At this time, the Customer's FARE is not added to the TOTAL FARE.

⑨ When the Game Time becomes 0, the game is over. The GAME OVER screen appears, with TOTAL EARNED, evaluation comment and RANKING displayed. If any credit(s) which is one play worth or more remains, the START LAMP unlit during game will then flash.

## 7 . EXPLANATION OF TEST AND DATA DISPLAY

By operating the switch unit, periodically perform the tests and data check. When installing the machine initially or collecting cash, or when the machine does not function correctly, perform checking in accordance with the explanations given in this section. The following shows tests and modes that should be utilized as applicable.



IMPORTANT!

### CAUTIONS TO BE HEEDED WHEN USING THE TEST MODE:

In the case where plural machines are linked for communication play, if even one seat enters the test mode, all of the linked seats will enter the test mode. Therefore, if any one of the linked machines is in play, use care so as not to use the test mode.

The contents of the setting changes made will not be effective unless the test mode is finished in the test mode. When the setting is changed, be sure to "EXIT" in the menu mode. Do not press the TEST BUTTON during network check at the time of turning the power on or exiting from the test mode. If anyone of the linked machines uses the test mode during network check, all other Seats will continue network checking. Cause all of the Seats to reenter the test mode and then have all of the Seats exit from the test mode simultaneously.

TABLE 7 EXPLANATION OF TEST MODE

ITEMS	DESCRIPTION	SECTIONS
INSTALLATION OF MACHINE	When the machine is installed, perform the following: 1. Check to see that each setting is as per standard setting made at the time of shipment. 2. In the INPUT TEST mode, check each SW and VR. 3. In the OUTPUT TEST mode, check each of lamps. 4. In the MEMORY TEST mode, check ICs on the IC Board.	7 - 10, 7 - 11 7 - 6 7 - 7 7 - 3, 7 - 4
MEMORY	Choose MEMORY TEST in the MENU mode to allow the MEMORY test to be performed. In this test, PROGRAM RAMs, ROMs, and ICs on the IC Board are checked.	7 - 3, 7 - 4
P	Periodically perform the following: 1. MEMORY TEST 2. Ascertain each setting. 3. In the INPUT TEST mode, test the CONTROL device 4. In the OUTPUT TEST mode, check each of lamps.	7 - 10, 7 - 11 7 - 6 7 - 7
CONTROL SYSTEM	1. In the INPUT TEST mode, check each SW and VR. 2. Adjust or replace each SW and VR. 3. If the problem can not be solved yet, check the CONTROL's moves.	7 - 6 8
MONITOR	In the MONITOR ADJUSTMENT mode, check to see if the MONITOR adjustment is appropriately made.	12
IC BOARD	1. MEMORY TEST 2. In the SOUND TEST mode, check the sound related ROMs.	7 - 2 7 - 8
DATA CHECK	Check such data as game play time and histogram to adjust the difficulty level, etc	7 - 15

## 7 - 1 SWITCH UNIT AND COIN METER



WARNING!

Never touch places other than those specified. Touching places not specified can cause electric shock and short circuit.



IMPORTANT!

- Adjust to the optimum sound volume by considering the environmental requirements of the installation location.
- If the COIN METER and the game board are electrically disconnected, game play is not possible.

Open COIN CHUTE DOOR, and the switch unit shown appears. The function of each switch is as follows:

### SWITCH UNIT

- ① **SOUND VOLUME**  
Controls the speaker volume of the right/left speakers.
- ② **TEST BUTTON (TEST SW)**  
For the handling of the TEST BUTTON, refer to the section on test mode.
- ③ **SERVICE BUTTON (SERVICE SW)**  
Gives credits without registering on the coin meter.

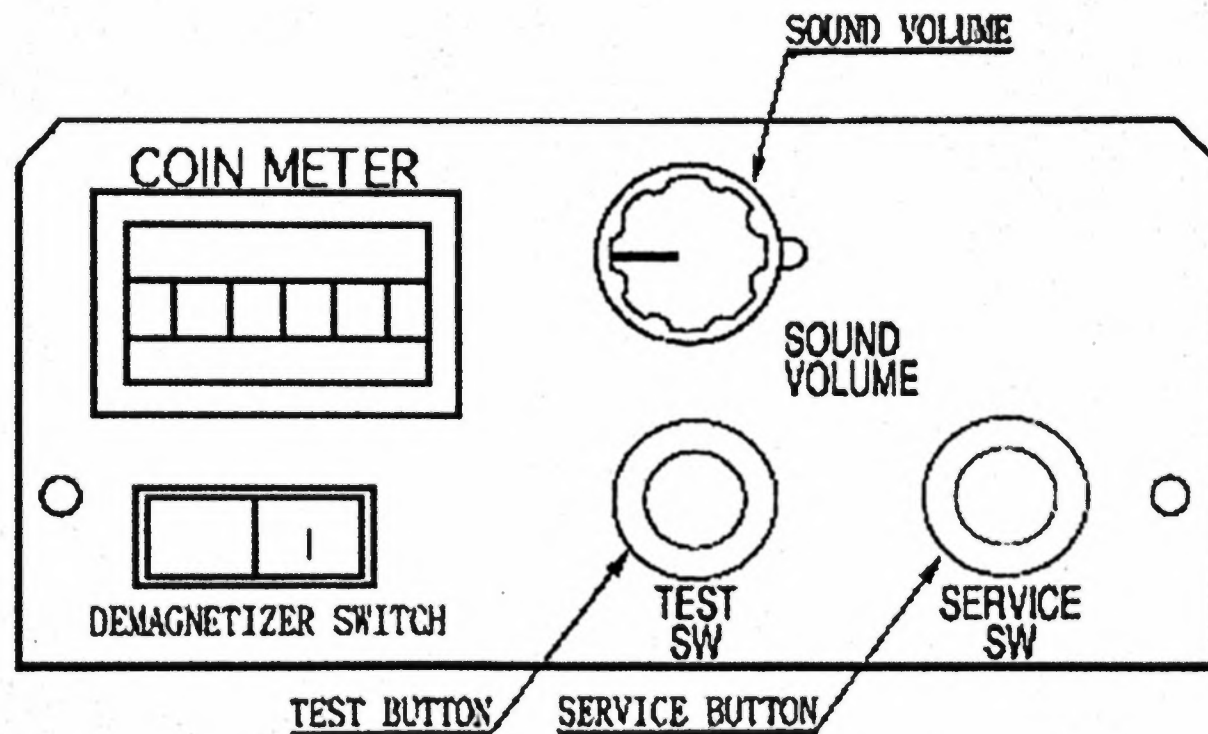

## 7 - 2 SYSTEM TEST MODE



**IMPORTANT!**

The contents of settings changed in the TEST mode are stored when the TEST mode is finished from EXIT in the MENU mode. If the power is turned off before the TEST mode is finished, the contents of setting change become ineffective.

Executing "BACKUP DATA CLEAR" in the SYSTEM TEST MODE does not clear the BOOKKEEPING data in the GAME TEST MODE.

Entering the TEST mode clears fractional number of coins less than one credit and BONUS ADDER data.

The SYSTEM TEST mode mainly allows for IC Board functioning check, monitor adjustment, coin assignments, etc. For details, refer to NAOMI SERVICE MANUAL. The following assignments, however, should be designated for this product.

CABINET TYPE:        1 PLAYER (S)  
 MONITOR TYPE:        HORIZONTAL  
 COIN CHUTE TYPE:    COMMON

## 7 - 3 GAME TEST MODE

### MENU MODE

SYSTEM MENU

RAM TEST  
 JVS TEST  
 SOUND TEST  
 C. R. T. TEST  
 SYSTEM ASSIGNMENTS  
 COIN ASSIGNMENTS  
 BOOKKEEPING  
 BACKUP DATA CLEAR  
 CLOCK SETTING

ROM BOARD TEST  
 -> GAME TEST MODE  
 [XXXXXXXXXXXXX]

EXIT  
 SELECT WITH SERVICE BUTTON  
 AND  
 PRESS TEST BUTTON

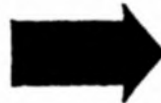

CRAZY TAXI TEST MENU

INPUT TEST  
 OUTPUT TEST  
 SOUND TEST  
 GAME ASSIGNMENTS  
 VOLUME SETTING  
 BOOKKEEPING  
 BACKUP DATA CLEAR  
 -> EXIT

SELECT WITH SERVICE BUTTON  
 AND PRESS TEST BUTTON

SYSTEM TEST MODE MENU

GAME TEST MODE MENU

- Press the TEST button to display the SYSTEM TEST MODE MENU.
- By pressing the SERVICE button, move the arrow (->) to select the GAME TEST MODE.
- Press the TEST button to enter GAME TEST MODE. The screen displays the GAME TEST MODE MENU.
- By pressing the SERVICE button, move the arrow (->) to select the desired item. Press the TEST button to execute the selected item.
- Select EXIT and press the TEST button to exit from the GAME TEST MODE and return to the SYSTEM TEST MODE MENU. Further, select EXIT and press the TEST button to finish SYSTEM TEST MODE and return to the normal mode.

## 7-4 INPUT TEST

Select INPUT TEST to have the screen shown below appear and to observe the status of each switch and the value of each V.R. on the Control Panel. Periodically check the status of each switch and V.R. on this screen.

INPUT TEST	
DRIVE GEAR	OFF
REVERSE GEAR	OFF
START	OFF
COIN CHUTE #1	OFF
COIN CHUTE #2	OFF
SERVICE	OFF
TEST	OFF
HANDLE	80H
ACCEL	30H
BRAKE	30H

PRESS TEST AND SERVICE BUTTON TO EXIT

FIG. 7.4 INPUT TEST

- By pressing each switch, if the display on the right-hand side of the name of each switch changes to ON from OFF, the SW and the wiring connections are satisfactory.
- To check CHUTE 1 & CHUTE 2 coin switches, open the COIN CHUTE DOOR and insert a coin(s) in the slot.
- Press either the TEST BUTTON and the START BUTTON to return to the test menu.

As a standard, refer to the following for each of the Volume's adjustment. By operating the Handle (Steering Wheel) and Pedal, if the V of each Volume guage smoothly moves as the corresponding value varies in a natural manner, then it is satisfactory.

## 7-5 OUTPUT TEST

OUTPUT TEST	
START LAMP	ON

PRESS TEST BUTTON TO EXIT

FIG. 7.5 OUTPUT TEST

Choose OUTPUT TEST to cause the following lower screen to appear. In this test, check the status of each lamp.

The right-hand side "ON" & "OFF" display of START LAMP automatically alternates. The lamp lights up when "ON" is displayed and goes off when "OFF" is displayed. Check to ensure that the lamp lights up and goes off in consistency with the display of "ON" and "OFF".

Press the TEST button to return to the TEST MENU.

## 7 - 6 SOUND TEST

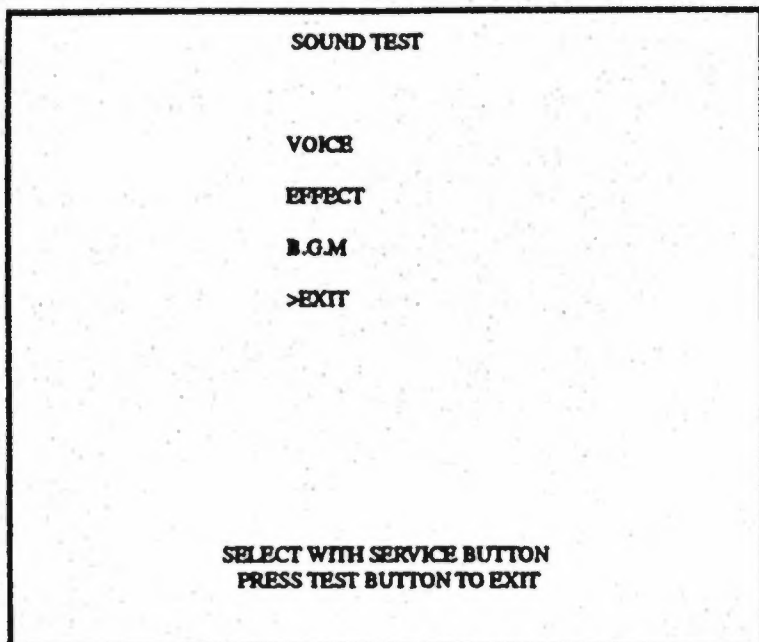

FIG. 7.6 SOUND TEST

This test mode allows each sound related board and speaker to be checked.

- Press the Service Button to select the sound to be tested, and press the Test Button to have the selected Sound Test screen appear.
- Select EXIT and press the Test Button to return to the Test Menu.

## 7 - 7 C.R.T. TEST

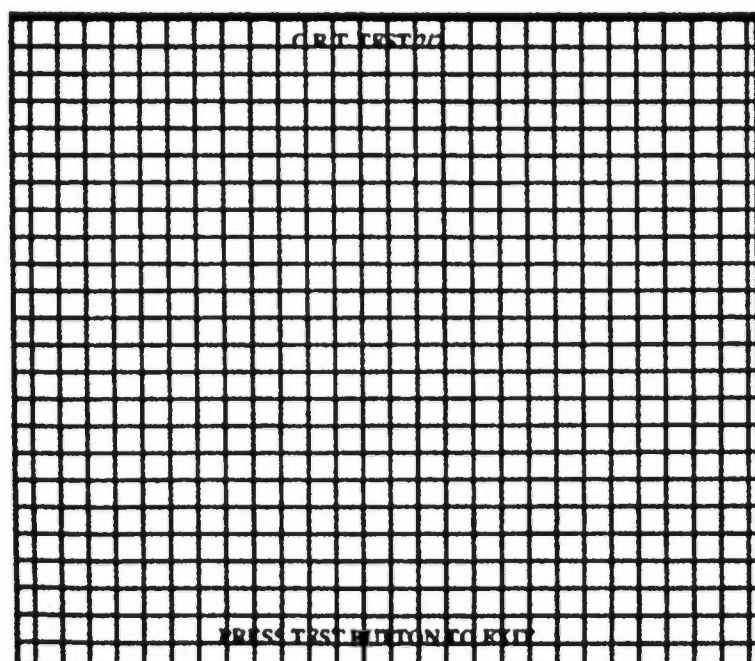
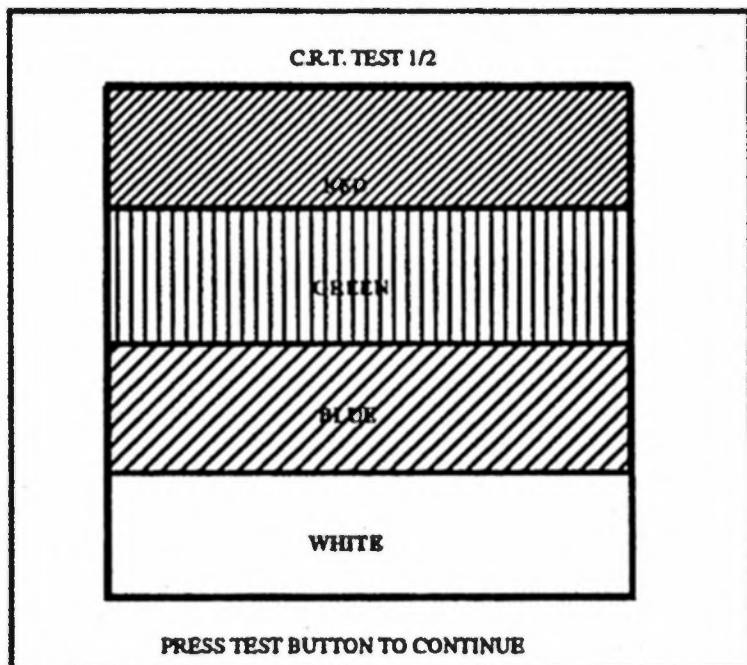

FIG. 7.7 C.R.T. TEST

- Select C.R.T. TEST to cause the MONITOR to display the screen shown left, allowing MONITOR adjustment status to be checked.
- Periodically check the MONITOR adjustment status on this screen.
- The screen (1/2) enables color adjustment check to be performed. The color bar of each of the 4 colors, i.e., red, green, blue, and white, is the darkest at the extreme left and becomes brighter towards the extreme right.
- Press the TEST BUTTON to shift to the next screen (2/2).
- The screen (2/2) allows screen size and distortion to be tested.
- Check if the CROSSHATCH FRAME LINE goes out of the screen and if the crosshatch lines are distorted.
- Press the TEST BUTTON to return to the MENU mode.

## 7 - 8 VOLUME SETTING

When VOLUME SETTING is selected, the following appears on the screen and each operating unit's Volume can be set.

If the operability is unsatisfactory, or when the Volume is adjusted or replaced, set the Volume in this mode.

The 3 kinds of Volume Settings for HANDLE, ACCEL, and BRAKE are to be set. The Max. value, Min. value for each and the HANDLE'S CENTER value are to be set as applicable.

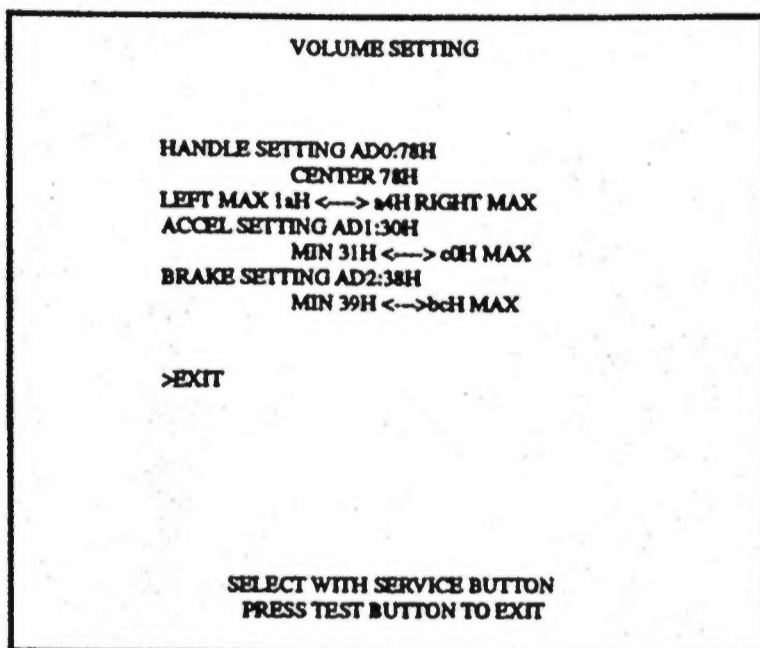

- ① Press the SERVICE button to select the Volume value to be changed.
- ② Press the TEST button to cause the characters of the selected Volume value to turn red.
- ③ Input the value in the manner corresponding to the selected item.
- ④ Press the SERVICE button to select EXIT, and press the TEST button to return to the MENU mode. At the same time the VOLUME SETTING is finished, the input values are stored as the Max. and Min. values.

FIG. 7.8 VOLUME SETTING

## 7 - 9 GAME ASSIGNMENTS

Selecting the GAME ASSIGNMENTS in the MENU mode causes the present game settings to be displayed and also the game settings changes (game difficulty, etc.) can be made. Each item displays the following content.

### SETTING CHANGE PROCEDURE

- ① Press the SERVICE BUTTON to move the ">" to the desired item.
- ② Choose the desired setting change item by using the TEST BUTTON.
- ③ To return to the MENU mode, move the arrow to EXIT and press the TEST BUTTON.

GAME ASSIGNMENTS	
START TIME	50
TIME DIFCULTY	4/8
GAME DIFFICULTY	4/8
>EXIT	
SELECT WITH SERVICE BUTTON AND PRESS TEST BUTTON TO EXIT	

- **START TIME**  
This is the time allotted at the time of game start. Setting is possible starting from the shortest time sequentially in order of 35, 40, 45, 50, 55, -60, 65, and 70.
- **TIME DIFFICULTY**  
Refers to the amount of BONUS TIME to be added when the taxi picks up the Customer. This can be set from 1/8 to 8/8 in 8 steps. The difficulty increases sequentially in order starting from 1/8.
- **GAME DIFFICULTY**  
Sets the difficulty level in 4 categories, i.e., EASY, NORMAL, HARD, and HARDEST.

## 7 - 10 COIN ASSIGNMENTS

The "COIN ASSIGNMENTS" mode permits you to set the start number of credits, as well as the basic numbers of coins and credits. This mode expresses "how many coins correspond to how many credits."

### SETTING CHANGE PROCEDURE



IMPORTANT!

Setting changes cannot be stored unless the TEST BUTTON is pressed while the arrow is on EXIT.

- ① Press the SERVICE BUTTON to move the arrow to the desired item.
- ② Choose the desired setting change item by using the TEST BUTTON.
- ③ To return to the MENU mode, move the arrow to EXIT and press the TEST BUTTON.

## 7 - 10 COIN ASSIGNMENTS

COIN ASSIGNMENTS			
COIN/CREDIT SETTING	#1		
CHUTE#1	1 COIN	1 CREDIT	
CHUTE#2	1 COIN	1 CREDIT	
ADDITIONAL SETTING			
MANUAL SETTING			
>EXIT			
SELECT WITH SERVICE BUTTON AND PRESS TEST BUTTON			

### COIN/CREDIT SETTING

Sets the CREDITS increase increment per coin insertion. There are 27 settings from #1 to #27, expressed in XX CREDIT as against XX COINS inserted. (TABLE 7.10a, 7.10b) #27 refers to FREE PLAY.

When the COIN CHUTE TYPE is set to INDIVIDUAL, there are some setting numbers not displayed as indicated in TABLE 7.10b.

### MANUAL SETTING

This allows credit increase setting as against coin insertion to be further set in the manner finer than COIN/CREDIT SETTING (refer to TABLE 7.10c).

TABLE 7.10a COIN/CREDIT SETTING (COIN CHUTE COMMON TYPE)

SETTING	FUNCTIONING OF CHUTE#1	
SETTING #1	1 COIN	1 CREDIT
SETTING #2	1 COIN	2 CREDITS
SETTING #3	1 COIN	3 CREDITS
SETTING #4	1 COIN	4 CREDITS
SETTING #5	1 COIN	5 CREDITS
SETTING #6	1 COIN	2 CREDITS
SETTING #7	1 COIN	5 CREDITS
SETTING #8	1 COIN	3 CREDITS
SETTING #9	1 COIN	4 CREDITS
SETTING #10	1 COIN	5 CREDITS
SETTING #11	1 COIN	6 CREDITS
SETTING #12	2 COINS	1 CREDIT
SETTING #13	1 COIN	1 CREDIT
SETTING #14	1 COIN	2 CREDITS
SETTING #15	1 COIN	1 CREDIT
	2 COINS	3 CREDITS
SETTING #16	1 COIN	3 CREDITS
SETTING #17	3 COINS	1 CREDIT
SETTING #18	4 COINS	1 CREDIT
SETTING #19	1 COIN	1 CREDIT
	2 COINS	2 CREDITS
	3 COINS	3 CREDITS
	4 COINS	5 CREDITS
SETTING #20	1 COIN	5 CREDITS
SETTING #21	5 COINS	1 CREDIT
SETTING #22	1 COIN	2 CREDITS
SETTING #23	2 COINS	1 CREDIT
	4 COINS	2 CREDITS
	5 COINS	3 CREDITS
SETTING #24	1 COIN	3 CREDITS
SETTING #25	1 COIN	1 CREDIT
	2 COINS	2 CREDITS
	3 COINS	3 CREDITS
	4 COINS	4 CREDITS
	5 COINS	6 CREDITS
SETTING #26	1 COIN	1 CREDITS
SETTING #27	FREE PLAY	

# MANUAL SETTING

Selecting MANUAL SETTING in the COIN ASSIGNMENTS mode displays the following screen.

MANUAL SETTING										
COIN TO CREDIT	1 COIN		1 CREDIT		---					①
BONUS ADDER	NO BONUS ADDER									②
COIN CHUTE #1 MULTIPLIER										
1 COIN COUNTS AS 1 COIN										
COIN	1	2	3	4	5	6	7	8	9	③
CREDIT	1	2	3	4	5	6	7	8	9	
COIN CHUTE #2 MULTIPLIER										
1 COIN COUNTS AS 1 COIN										
COIN	1	2	3	4	5	6	7	8	9	
CREDIT	1	2	3	4	5	6	7	8	9	
>EXIT										
SELECT WITH SERVICE BUTTON AND PRESS TEST BUTTON										

FIG. 7.11b MANUAL SETTING

- ① Determines Coin/Credit setting.
- ② This sets how many coins should be inserted to obtain one Service Coin.
- ③ This sets how many tokens one coin represents.

Table 7.10c MANUAL SETTING

COIN TO CREDIT	1 COIN	1 CREDIT
	2 COINS	1 CREDIT
	3 COINS	1 CREDIT
	4 COINS	1 CREDIT
	5 COINS	1 CREDIT
	6 COINS	1 CREDIT
	7 COINS	1 CREDIT
	8 COINS	1 CREDIT
	9 COINS	1 CREDIT
BONUS ADDER	NO BONUS ADDER	
	2 COINS GIVE 1 EXTRA COIN	
	3 COINS GIVE 1 EXTRA COIN	
	4 COINS GIVE 1 EXTRA COIN	
	5 COINS GIVE 1 EXTRA COIN	
	6 COINS GIVE 1 EXTRA COIN	
	7 COINS GIVE 1 EXTRA COIN	
	8 COINS GIVE 1 EXTRA COIN	
	9 COINS GIVE 1 EXTRA COIN	
COIN CHUTE MULTIPLIER	1 COIN COUNTS AS 1 COIN	
	1 COIN COUNTS AS 2 COINS	
	1 COIN COUNTS AS 3 COINS	
	1 COIN COUNTS AS 4 COINS	
	1 COIN COUNTS AS 5 COINS	
	1 COIN COUNTS AS 6 COINS	
	1 COIN COUNTS AS 7 COINS	
	1 COIN COUNTS AS 8 COINS	
	1 COIN COUNTS AS 9 COINS	

## 7 - 11 BOOKKEEPING

Choosing BOOKKEEPING in the MENU mode displays the data of operating status up to the present are shown on 2 pages. Press the TEST BUTTON to proceed to PAGE 2/2.

BOOKKEEPING		PAGE1/3
COIN CHUTE #1		XXXXXXXXXXXX
COIN CHUTE #2		XXXXXXXXXXXX
TOTAL COINS		XXXXXXXXXXXX
COIN CREDITS		XXXXXXXXXXXX
SERVICE CREDITS		XXXXXXXXXXXX
TOTAL CREDITS		XXXXXXXXXXXX
NUMBER OF GAMES		XXXXXXXXXXXX
TOTAL PLAY	TIME	XDXXHXXMXXS
AVERAGE PLAY	TIME	XXMXXS
LONGEST PLAY	TIME	XXMXXS
SHORTEST PLAY	TIME	XXMXXS

PRESS TEST BUTTON TO CONTINUE

FIG. 7.11a BOOKKEEPING (1/3)

- **COIN CHUTE#\*:**  
Number of coins put in each Coin Chute.
- **TOTAL COINS:**  
Total number of activations of Coin Chutes.
- **COIN CREDITS:**  
Number of credits registered by inserting coins.

In Page 2/3, Histogram of Number of Play as against Play Time is displayed. For setting the DIFFICULTY, refer to this histogram.

Page 3/3 displays the character's selected frequency at the time of Game Start.

BOOKKEEPING PAGE 2/3			
TIME HISTOGRAM			
COURSE	BEGINNER	ADVANCED	EXPERT
-2M29S	0	0	0
2M30S-2M44S	0	0	0
2M45S-2M59S	0	0	0
3M00S-3M14S	0	0	0
3M15S-3M29S	0	0	0
3M30S-3M44S	0	0	0
3M45S-3M59S	0	0	0
4M00S-4M14S	0	0	0
4M15S-4M29S	0	0	0
4M30S-	0	0	0

PRESS TEST BUTTON TO EXIT

FIG. 7.11b BOOKKEEPING (2/3)

BOOKKEEPING 3/3	
FAVORITE CHARACTER	
AXEL	0
B.DJOE	0
GENA	0
GUS	0

SELECT WITH SERVICE BUTTON  
PRESS TEST BUTTON TO EXIT

FIG. 7.11c BOOKKEEPING (3/3)

## 7 - 12 BACKUP DATA CLEAR

BACKUP DATA CLEAR	
YES (CLEAR)	>NO (CANCEL)

SELECT WITH SERVICE BUTTON  
PRESS TEST BUTTON TO EXIT

FIG. 7.12 BACKUP DATA CLEAR

Clears the contents of BOOKKEEPING and high score player ranking entry.

- When clearing, bring the arrow to "YES" and when not clearing, to "NO", by using the SERVICE BUTTON, and push the TEST BUTTON.
- When the data has been cleared, "COMPLETED" will be displayed. Bring the arrow to "NO" and press the TEST BUTTON to cause the MENU mode to return on to the screen.
- Note that the contents of the GAME SETTING, COIN SETTING, and BOARD SETTING are not affected by BACKUP DATA CLEAR operation.

## 8. HANDLE MECHA



- In order to prevent an electric shock and short circuit, be sure to turn power off before performing work by touching the interior parts of the product.
- Be careful so as not to damage wirings. Damaged wiring can cause an electric shock or short circuit accident.

In the test mode, if the steering wheel's VR variations are not within the allowable range, the VR installation position adjustments or VR replacement is needed. Also, be sure to apply grease to the VR gear portion once every 3 months.

### 8 - 1 REMOVING THE CONTROL PANEL

- ① Turn the power switch off.
- ② Remove a total of 4 tamperproof screws from both sides of the control panel's front.
- ③ Remove the two tamperproof screws from the underside of the control panel.
- ④ Wiring connectors are connected inside the control panel. Carefully draw the control panel in a manner so as not to damage wiring.
- ⑤ Disconnect the wiring connector.

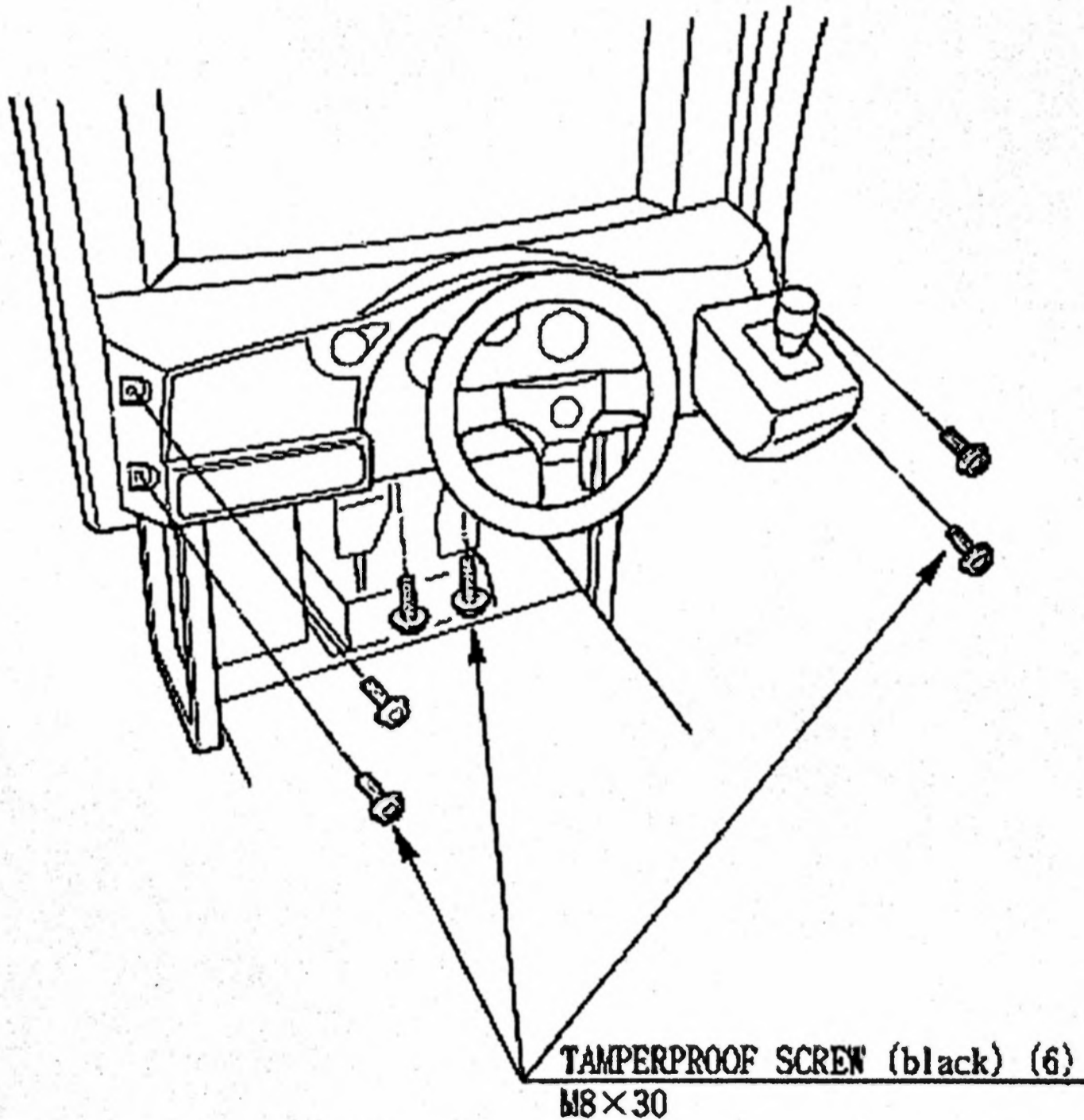

## 8 - 2 REPLACING AND ADJUSTING THE HANDLE'S VR



- Never touch places other than those specified. Touching places not specified can cause electric shock and/or short circuit.
- After the replacement or adjustment of the VR, be sure to set the variable value of the VR in the test mode's Volume Setting.

### REPLACING THE VOLUME

- ① Turn off the power.
- ② Disconnect the connector.
- ③ Take out the 2 screws which secure the volume Bracket and remove the Volume Bracket.
- ④ Take out the 2 screws to remove the Volume Gear and replace the Volume.
- ⑤ After replacing the Volume, perform Volume setting in the Volume Setting Mode.

### ADJUSTING THE VOLUME

- ① In the Test Mode, have the Volume value indicating screen displayed.
- ② Loosen the 2 screws which secure the Volume Bracket to disengage Gear Mesh.
- ③ With the Steering Wheel in the centering position, cause gears to be engaged in the manner so that the Volume Shaft is in the status shown below.
- ④ Fasten screws which secure the Volume Bracket.
- ⑤ Perform Volume setting as per the Volume Setting Mode.

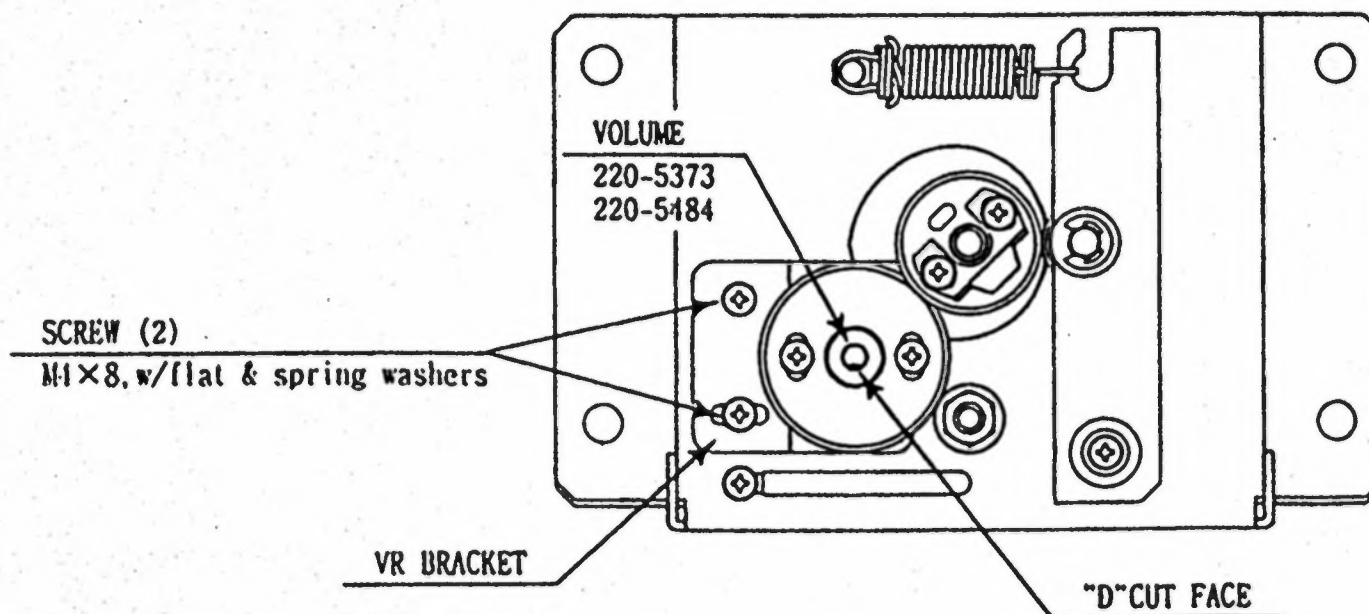

### 8 - 3 GREASING



- Never touch places other than those specified. Touching places not specified can cause electric shock and/or short circuit.
- After the replacement or adjustment of the VR, be sure to set the variable value of the VR in the test mode's Volume Setting.

Apply greasing to the Volume gear mesh portion every 3 months.

For spray greasing, use Grease Mate (Part No. 090-0066).

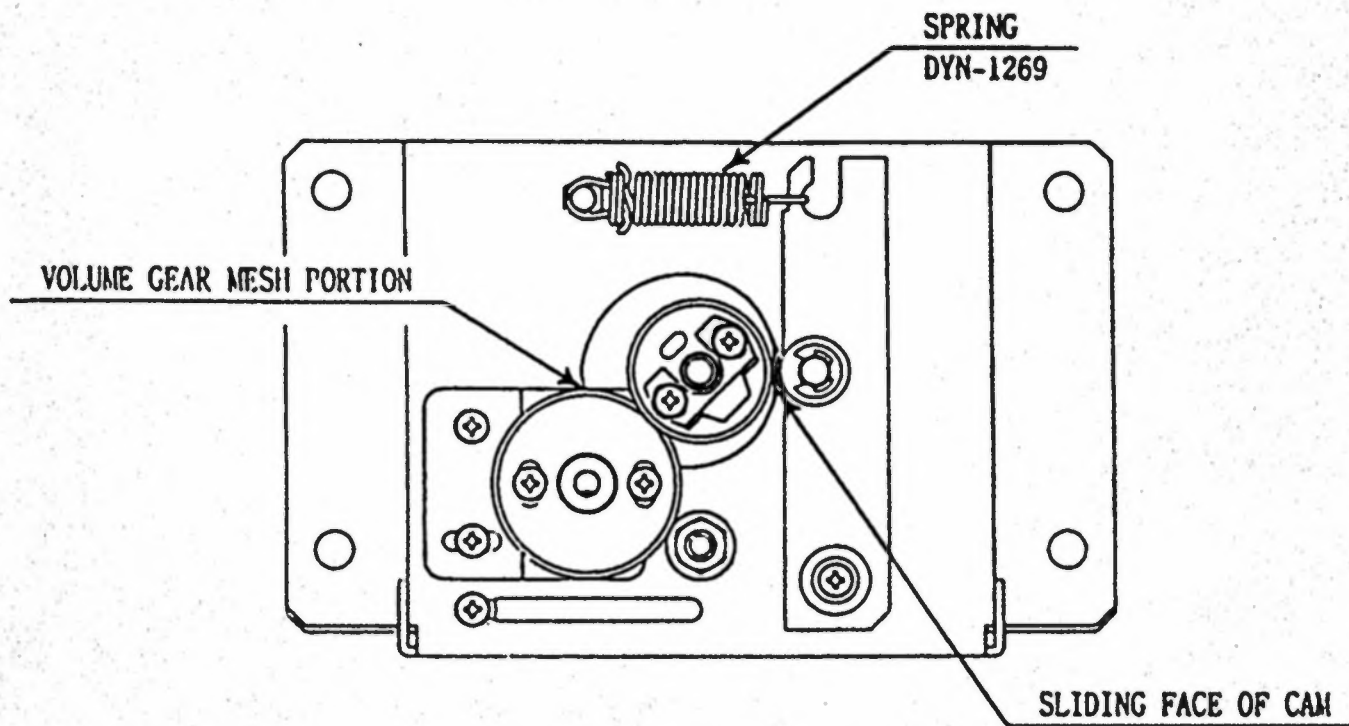

## 9. SHIFT LEVER



- In order to prevent electric shock and short circuit, be sure to turn off the power before performing work on the interior parts of the product.
- Be careful not to damage wiring. Damaged wiring can cause electric shock or short circuit.
- Do not touch places other than those specified. Touching places other than those specified can cause an electric shock or short circuit accident.

If the Shift Lever operation is not satisfactory, remove the Shift Lever in the following procedure and replace the microswitch.

### 9 - 1 REMOVING THE SHIFT LEVER

- ① Turn Power off.
- ② Take out the 4 SPECIAL BOLTS and pull the SHIFT LEVER UNIT upward by paying careful attention so as not to damage the wiring.
- ③ Disconnect the 2 connectors to allow the unit to be removed.
- ④ When reinstalling, follow the procedure opposite as when removing. At this time, ensure that "DOWN" display appears on the upper part as shown.

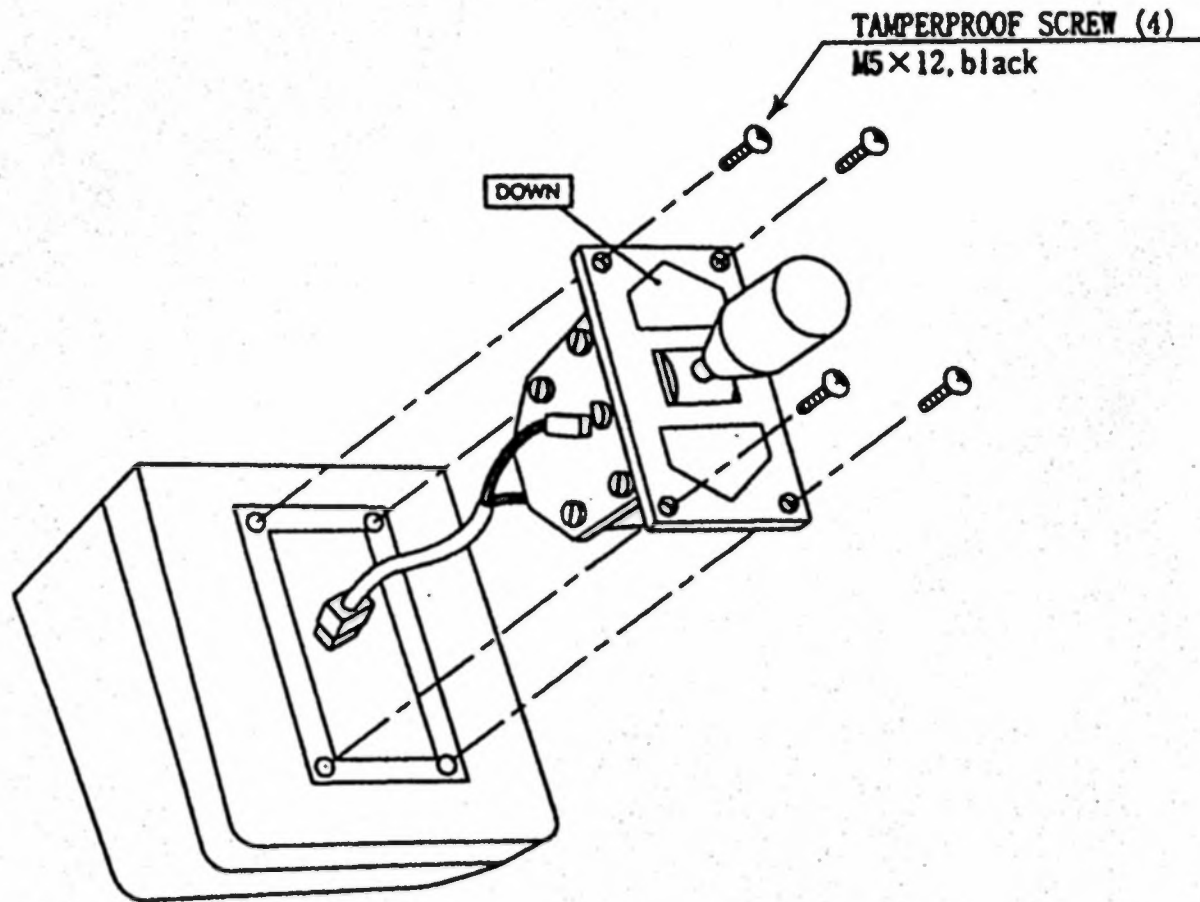

## 9-2 SWITCH REPLACEMENT

Each microswitch is secured with 2 screws. Remove the 2 screws and replace the Microswitch.

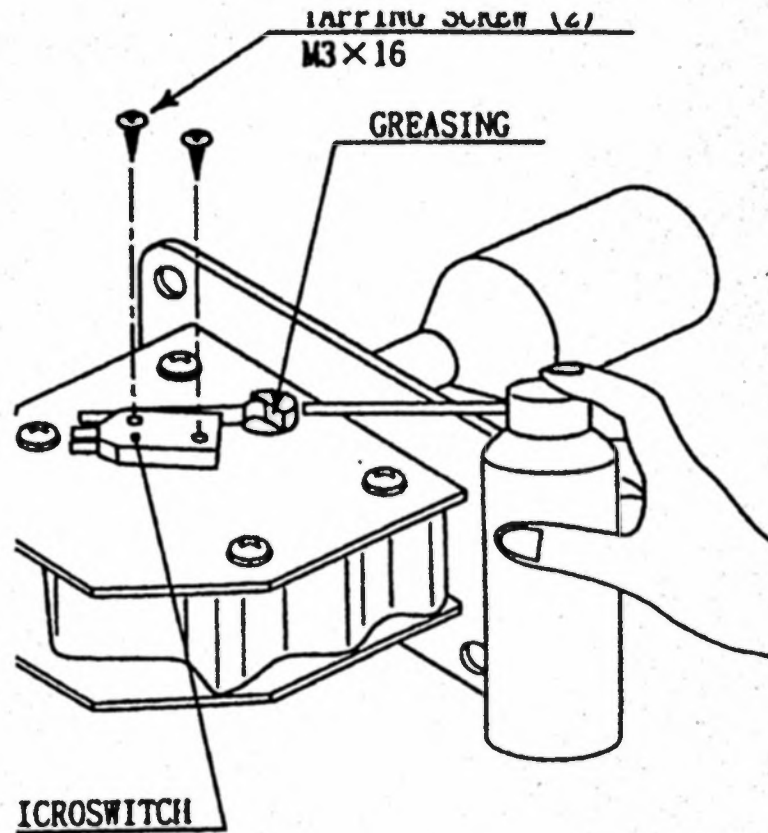

After replacing the Switch, check to see if the switch is inputted as per Shift Lever operation in the Test Mode.

4x6

TO BE RELEASED  
11/25/04 TOWN

## 10. ACCEL & BRAKE(S)



- In order to prevent an electric shock and short circuit, be sure to turn power off before performing work by touching the interior parts of the product.
- Be careful so as not to damage wirings. Damaged wiring can cause an electric shock or short circuit accident.
- Do not touch places other than those specified. Touching places not specified can cause an electric shock or short circuit accident.

If Accel and Brake operation is not satisfactory, adjustment of Volume installation position or Volume replacement is needed. Also, be sure to apply greasing to the gear mesh portion once every three months.

### 10 - 1 ADJUSTING AND REPLACING THE V.R.

	When released:		When stepped on:
ACCEL. :	Under 30 H	↔	Over C0H
BRAKE :	Under 30 H	↔	Over C0H

Check Volume values in the Test Mode.

Since work is performed inside the energized cabinet, be very careful so as not to touch undesignated portions. Touching places not specified can cause an electric shock or short circuit.

- ① Take out the 2 truss screws and remove the Front Cover from the Accel. & Brake unit.
- ② Loosen the screw which secures the Potentiobase, and adjust the Volume Value by moving the Base.
- ③ Secure the Potentiobase.
- ④ Perform Volume setting in the Volume Setting Mode.

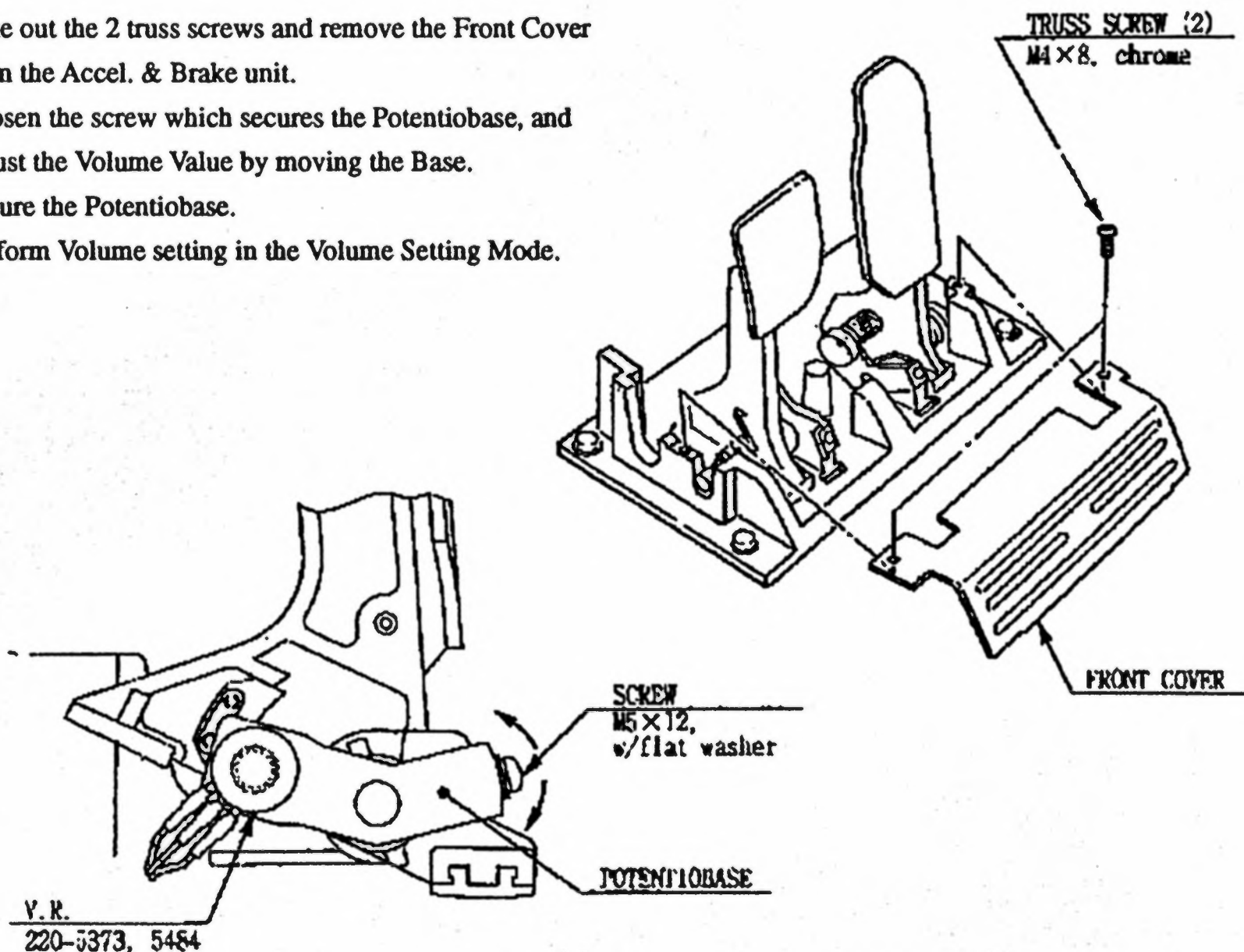

Check Volume values in the Test Mode.

Since work is performed inside the energized cabinet, be very careful so as not to touch undesigned portions. Touching places not specified can cause an electric shock or short circuit.

- ① Take out the 2 truss screws and remove the Front Cover from the Accel. & Brake unit.
- ② Loosen the screw which secures the Potentiobase, and adjust the Volume Value by moving the Base.
- ③ Secure the Potentiobase.
- ④ Perform Volume setting in the Volume Setting Mode.

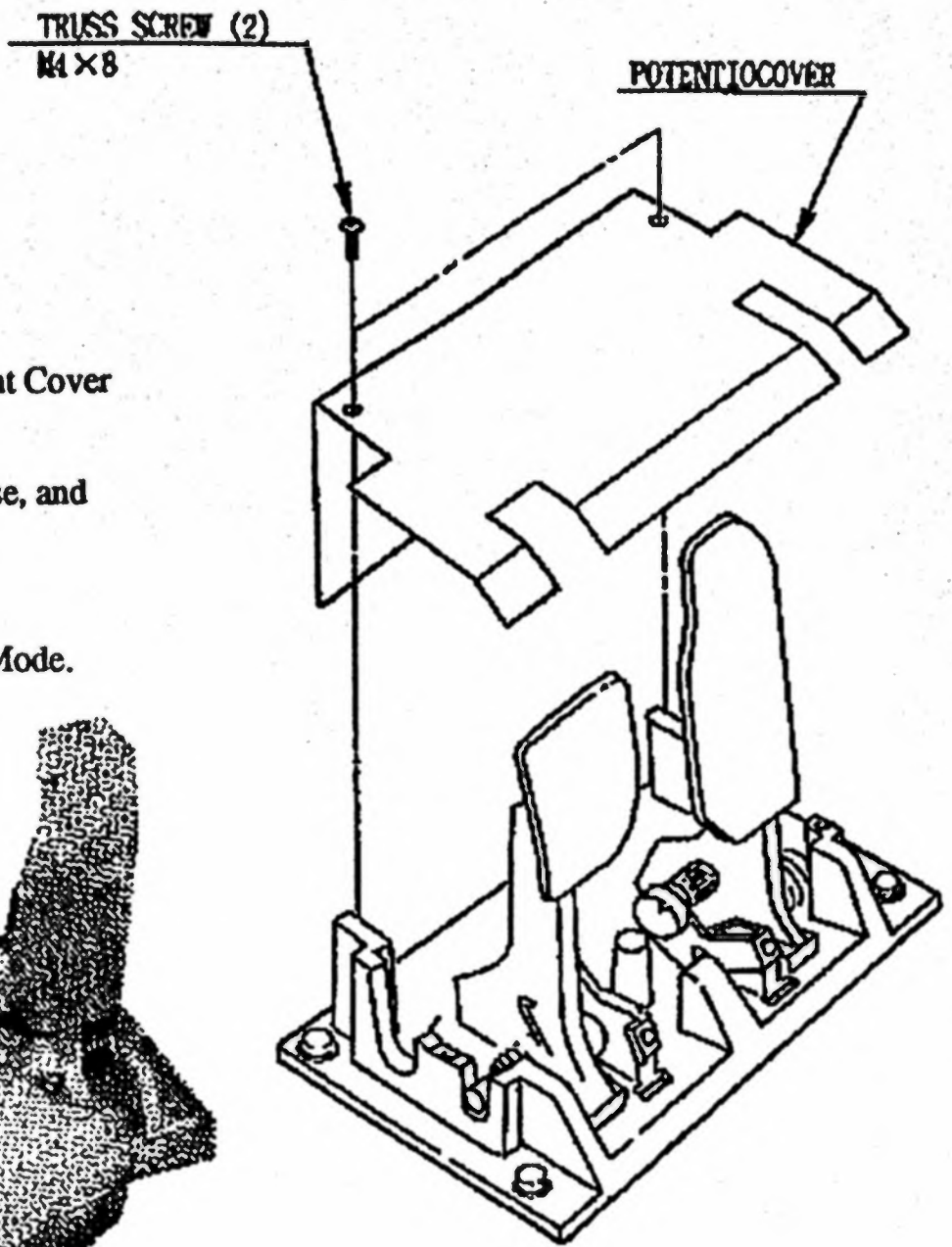
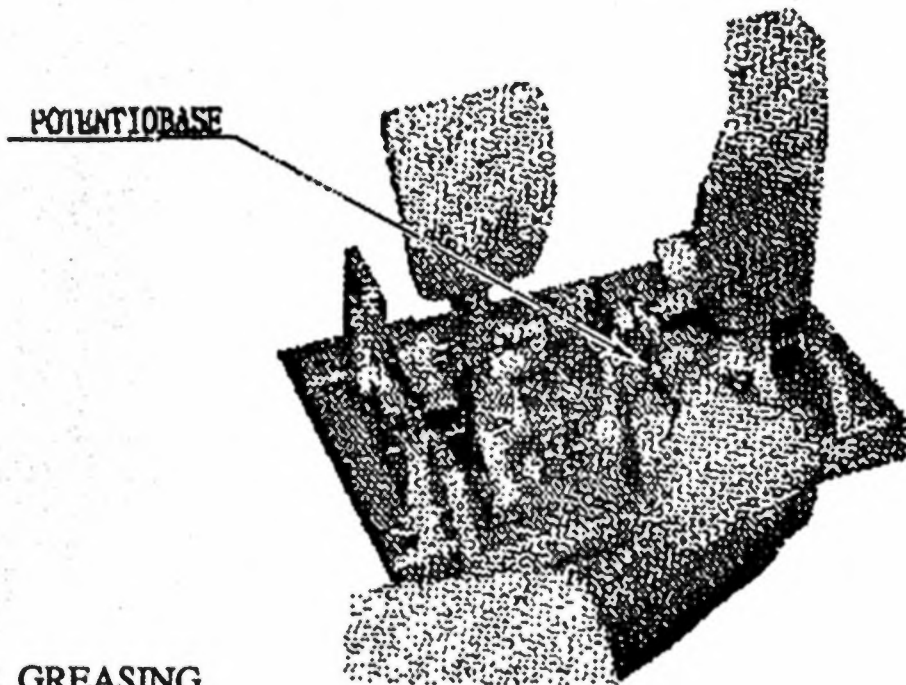

#### 10 - 2 GREASING



IMPORTANT!

Be sure to use designated grease. Using undesigned grease can cause parts damage.

Once every 3 months, apply greasing to the Spring and Gear Mesh portion. For spray greasing, use GREASE MATE (PART No. 090-0066).

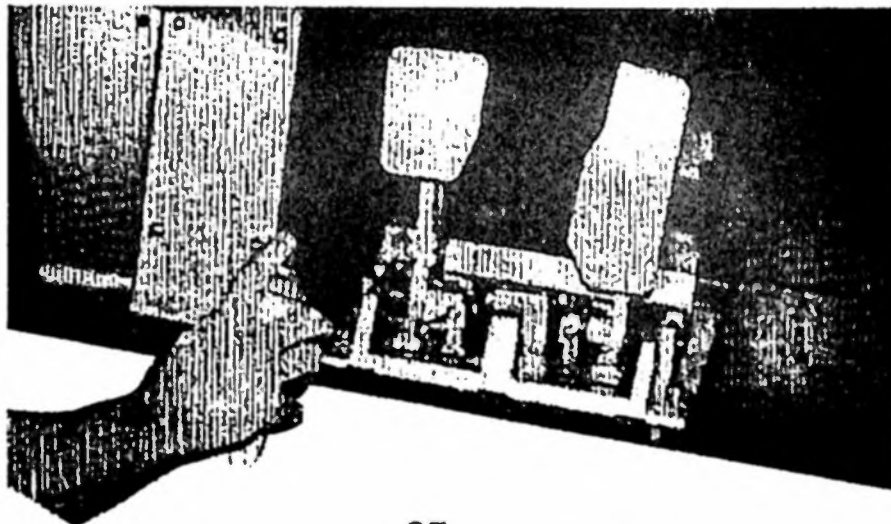

## 11 . COIN SELECTOR

### HANDLING THE COIN JAM

If the coin is not rejected when the **REJECT BUTTON** is pressed, open the coin chute door and open the selector gate. After removing the jammed coin, put a normal coin in and check to see that the selector correctly functions.

### CLEANING THE COIN SELECTOR

The coin selector should be cleaned once every 3 months. When cleaning, follow the procedure below:

- ① Turn the power for the machine **OFF**.  
Open the coin chute door.
- ② Open the gate and dust off by using a soft brush (made of wool, etc.).
- ③ Remove and clean smears by using a soft cloth dipped in water or diluted chemical detergent and then squeezed dry.
- ④ Remove the **CRADLE**.  
When removing the retaining ring(**E-ring**), be very careful so as not to bend the shaft.
- ⑤ Remove stain from the shaft and pillow portions by wiping off with a soft cloth, etc.
- ⑥ After wiping as per #5 above, further apply a dry cloth, etc. to cause the coin selector to dry completely.

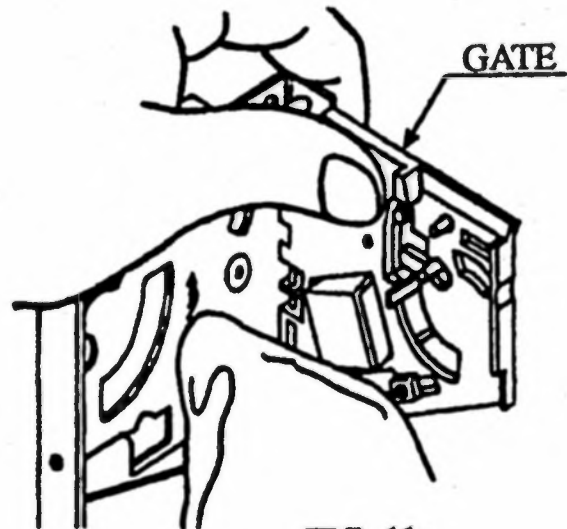

FIG. 11a

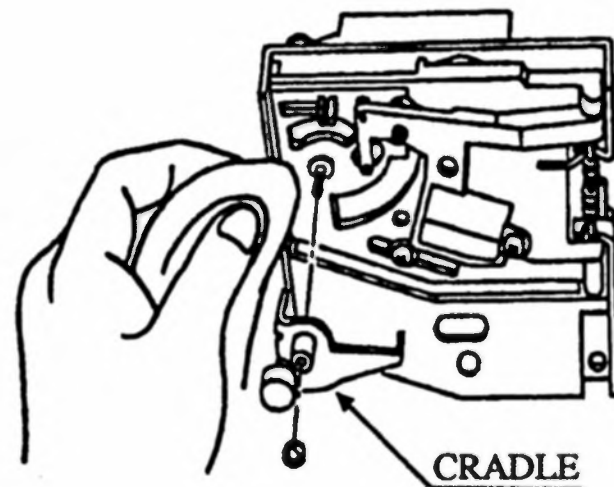

FIG.11b



IMPORTANT!

- Never apply machine oil, etc. to the coin selector
- After cleaning the Coin Selecting, Insert a regular coin in the normal working status and ensure that the Selector correctly functions.

### COIN INSERTION TEST

Once a month, when performing the **COIN SW TEST**, simultaneously check the following:

- Does the Coin Meter count satisfactorily?
- Does the coin drop into the Cashbox correctly?
- Is the coin rejected when inserted while keeping the **REJECT BUTTON** is pressed down?

Insert a coin while keeping the Reject Button pressed down and check if it is rejected.

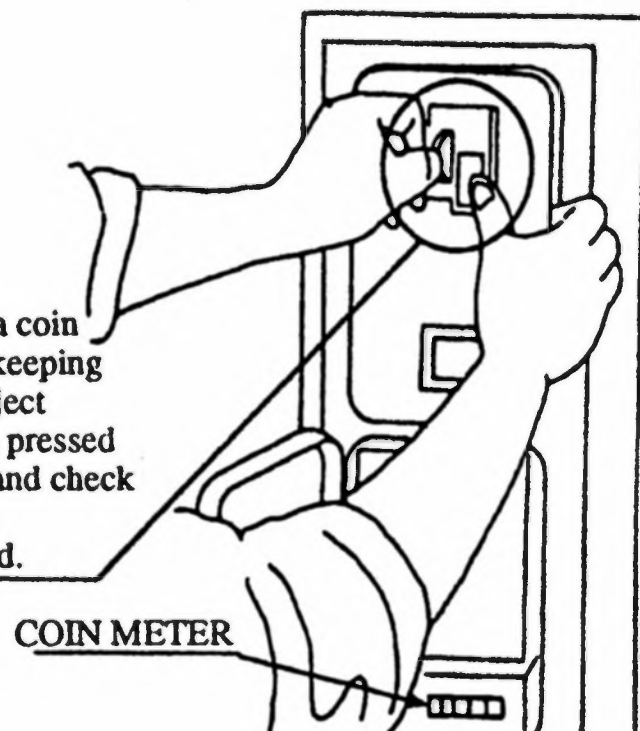

FIG. 11c

## OPTIONAL DOLLAR BILL ACCEPTOR

● THE COIN DOOR ASSEMBLY USED ON **CRAZY TAXI** COMES EQUIPPED TO ACCEPT A DOLLAR BILL ACCEPTOR. ALL NEEDED WIRING CONNECTIONS ARE CONVENIENTLY LOCATED INSIDE THE GAME FOR THIS APPLICATION.

● THE COIN DOOR CAN ACCCOMMODATE THE FOLLOWING VALIDATORS:

HOLE POSITION#1  
(FORWARD-MOST POSITION)

Mars 2000 series

HOLE POSITION#2

Mars 2000 series  
DBV45 (JCM)

HOLE POSITION #3

CURRENTLY NOT USED

HOLE POSITION #4

DSI01\*

\*The back flange on the chute can be removed for hold position #4. If the flange is not removed, it may interfere with the back of the cabinet.

The frame and cashbox enclosure on this coindoor has been modified to accommodate a Mars 2000 series upstacker. A 2000 series stacker can be added by simply removing the top two entry door and replacing it with a one entry door with a cut-out for a stacker. This one entry door can be ordered through Coin Controls or one of Coin Controls authorized distributors. The part number is 91-4000-01. The Mars stacker can be obtained through an authorized Mars distributor.

# COIN CONTROLS INTERNATIONAL



1850 HOWARD ST., BLK GROVE IL 60007  
(847) 228-1810

## OVER/UNDER TWO ENTRY COIN DOOR\*

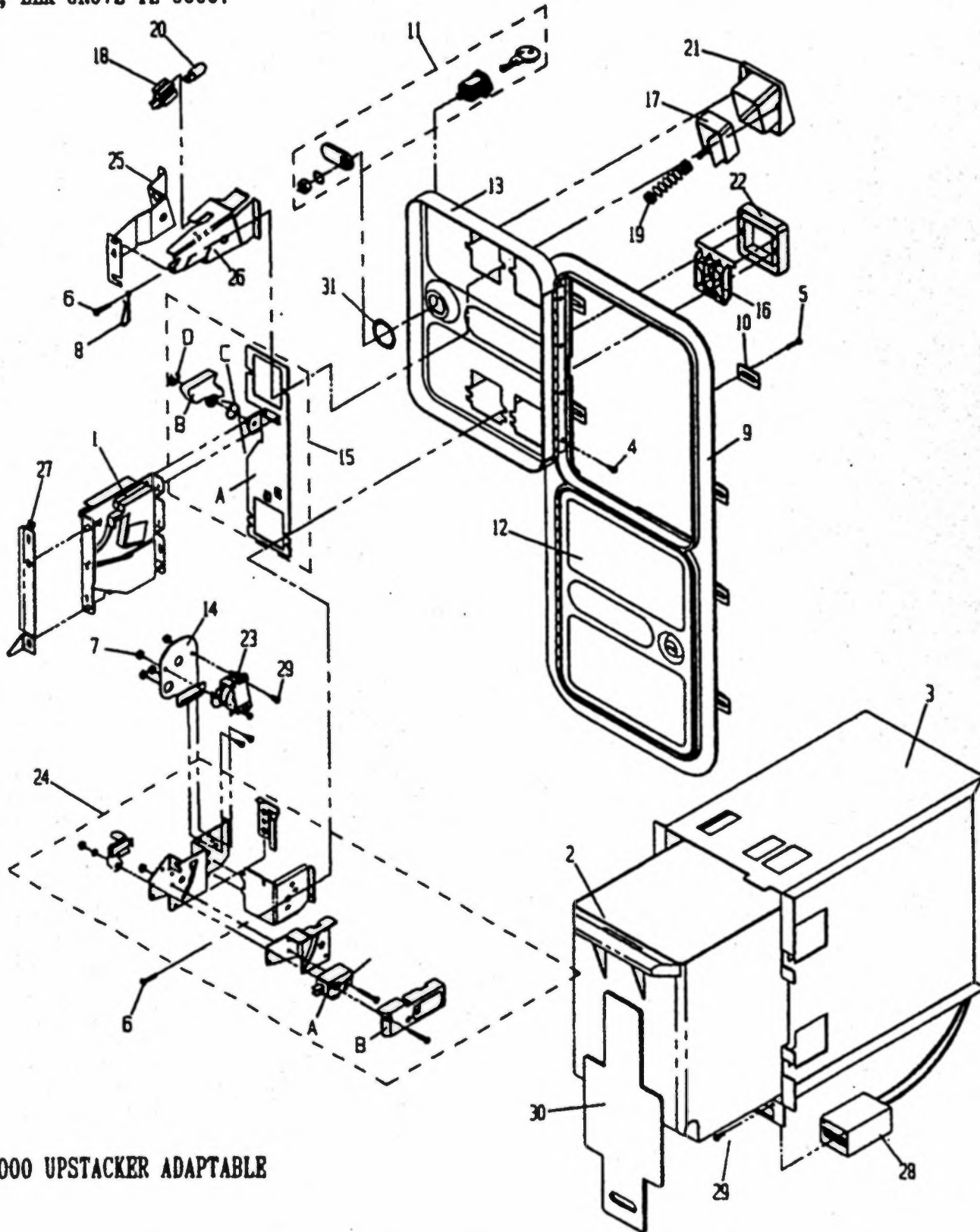

\* MARS SERIES 2000 UPSTACKER ADAPTABLE

PART #	DESCRIPTION	COST	PART #	DESCRIPTION	COST	PART #	DESCRIPTION	COST
1)	12-4050-XX S-10 ACCEPTOR	19.50	16)	91-1109-16 REJECT FLAP NYLON, BLACK	2.70	28)	23-1011-00 12V DC METER	8.50
	12-4150-011 S-7 US #.25	12.00	17)	91-1113-01 ENTRY/REJECT BUTTON 25c	4.45		23-1103-00 4.5V DC METER	8.50
2)	20-4177-00 PLASTIC CASEBOX	7.40	18)	91-1117-00 LAMPHOLDER	1.40	29)	90-1032-01 METER & LOCKOUT SCREW	.25
3)	20-4189-00 ENCLOSURE, Z2000	27.50	19)	91-1121-00 E/R BUTTON SPRING	.80	30)	22-1400-00 LOCKING BAR	7.00
4)	90-1002-00 HINGE SCREW	.25	20)	91-1118-00 6V LAMP WEDGE BASE	.95	31)	90-1019-00 3/4" LOCKWASHER	.25
5)	90-1003-00 CLAMP SCREW	.95	21)	91-1311-16 BUTTON BEZEL BLACK	2.70			
6)	90-1017-00 SCREW BEZEL NYLON	.25	22)	91-1312-16 REJECT BEZEL BLACK	2.70			
7)	90-1206-02 #4-40 KEP NUT	.25	23)	91-2125-00 12V LOCKOUT COIL ASSEMBLY	12.85			
8)	90-1300-00 KEYBOOK	.35	24)	91-2216-16 MICROSWITCH ASSEMBLY	15.00			
9)	91-0508-16 FRAME	30.00	24A)	91-1116-16 MICROSWITCH BLACK	5.40			
10)	91-0506-00 CLAMP	.45		91-1116-11 MICROSWITCH WHITE	5.40			
11)	91-0547-00 DOUBLE D CAN LOCK	5.25		91-1116-10 MICROSWITCH RED	5.40			
12)	91-0603-16 BLACK MINI DOOR	8.40	24B)	91-1125-00 MICROSWITCH PLASTIC COVER	.85			
13)	91-0604-16 2 ENTRY UPPER DOOR	10.00	25)	92-1002-01 COIN INLET LAMP SIDE	1.80			
14)	91-1008-039 LOCKOUT BRACKET	4.30	26)	92-1002-021 COIN INLET COVER SIDE	1.80			
15)	91-1008-107 BASEPLATE ASSEMBLY	5.00	27)	92-1002-10 MOLD NOTCH BRACKET	1.50			

## 12. MONITOR



**CAUTION!**

When performing such work as installing and removing the monitor, inserting and disconnecting the external connectors to and from monitor, be sure to disconnect the power connector (plug) before starting work. Proceeding the work without following this instruction can cause electric shock or malfunctioning.

Using the monitor by converting it without obtaining a prior permission is not allowed. SEGA shall not be liable for any malfunctioning and accident caused by said conversion.



**WARNING!**

### Primary side and secondary side

The monitor's circuit which is divided into the Primary side and secondary side, is electrically isolated. Do not touch the primary side and the secondary side simultaneously. Failing to observe the instruction can cause electric shock, and this is very dangerous. When making monitor adjustments, use a non-conductive driver and make adjustment without touching any other part other than the Adjustment V.R. and Knob. Also, be sure not to cause a short-circuit to the Primary side and the Secondary side. If short-circuited, it can cause electric shock or malfunctioning, which is very dangerous.

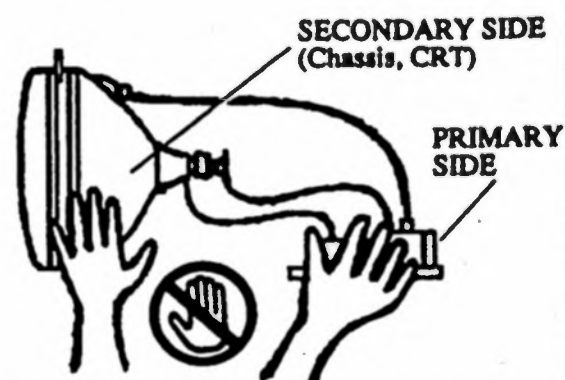

### High tension Voltage

Some of the parts inside the monitor are subject to high-tension voltage in excess of 20,000 volts and very dangerous. Therefore, do not touch the monitor interior. Should soldering & paper wastes, etc. be mixed in the monitor, turn the power off so as not to cause malfunctioning or fire hazard.

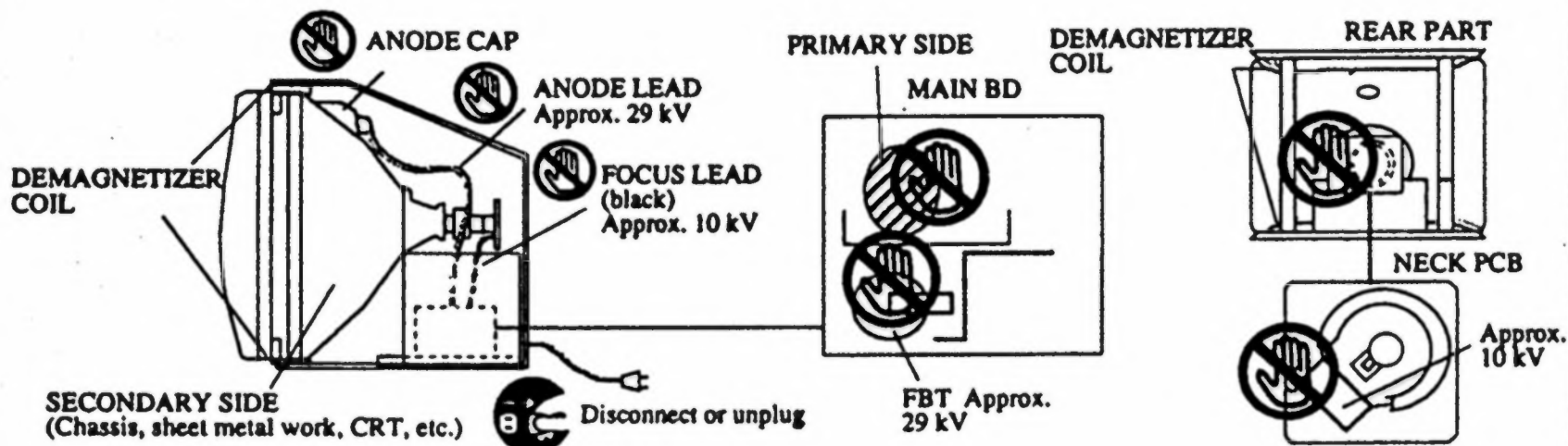

### Connecting the CRT and PCB

For combining the CRT and PCB, use the specified part No. to maintain the status of adjustments made at the factory. The anode of the CRT itself will be accumulatively charged as time elapses, generating high tension voltage which is very dangerous. The monitor should be used with the Chassis, CRT and PCB assembled. When repair, etc. is required at the time of malfunctioning, be sure to send it in an "as assembled" condition. If these are disassembled, what's charged to said high tension voltage can be discharged, causing a very hazardous situation. Therefore, under no circumstances should it be disassembled.



**CAUTION!**

### Static Electricity

Touching the CRT surface sometimes causes you to slightly feel electricity. This is because the CRT surfaces are subject to static and will not adversely affect the human body.

### Installation and removal

Ensure that the Magnetizer Coil, FBT (Fly-Back Transformer), Anode Lead and Focus Lead are not positioned close to the sheet metal work's sharp edges, etc. and avoid damaging the insulated portions so as not to cause an electric shock and malfunctioning. (For the name of parts, refer to the above figures.)



CAUTION!

For the purpose of static prevention, special coating is applied to the CRT face of this product. To protect the coating, pay attention to the following points. Damaging the coating film can cause electric shock to the customers. For the caution to be heeded when clearing, refer to the Section of Periodic inspection Table.

Do not apply or rub with a hard item (a rod with pointed edge, pen, etc.) to or on C.R.T. surfaces.

Avoid applying stickers, seals, etc. on the C.R.T. face.

Do not remove aluminum foils from the C.R.T. corners. Removing the aluminum foils can cause static prevention effects to be lowered.

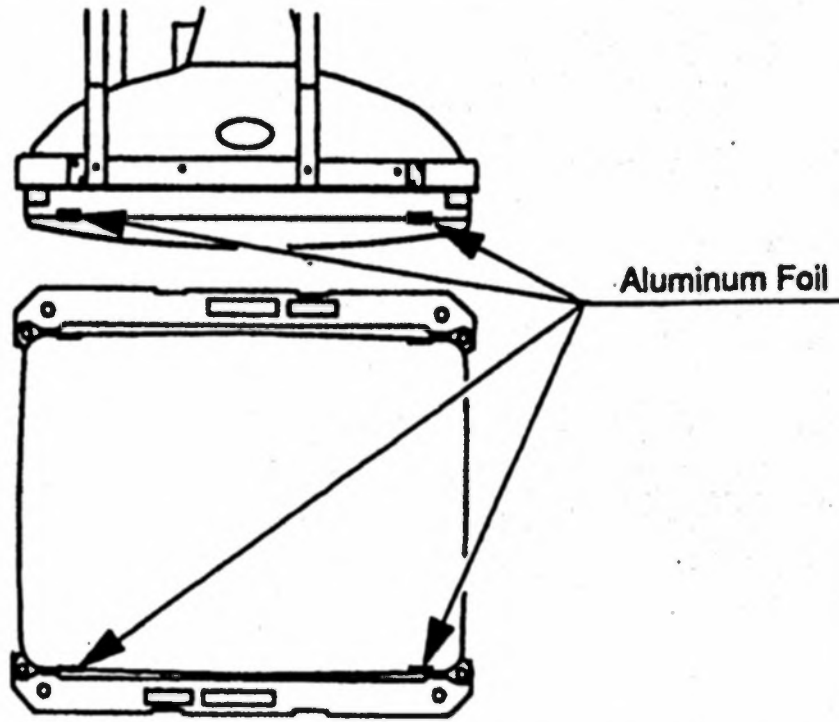

CAUTION!

Monitor adjustments have been made at the time of shipment. Therefore do not make further adjustment without a justifiable reason.

Adjusting the monitor which contains high tension parts is dangerous work. Also, an erroneous adjustment can cause deviated synchronization and image fault, resulting in malfunctioning.

When making adjustment, utilize a resinous Alignment Rod. Servicing with bare hands or using conductive tools can cause electric shock.

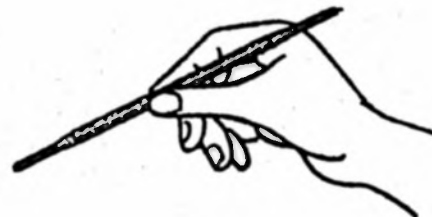
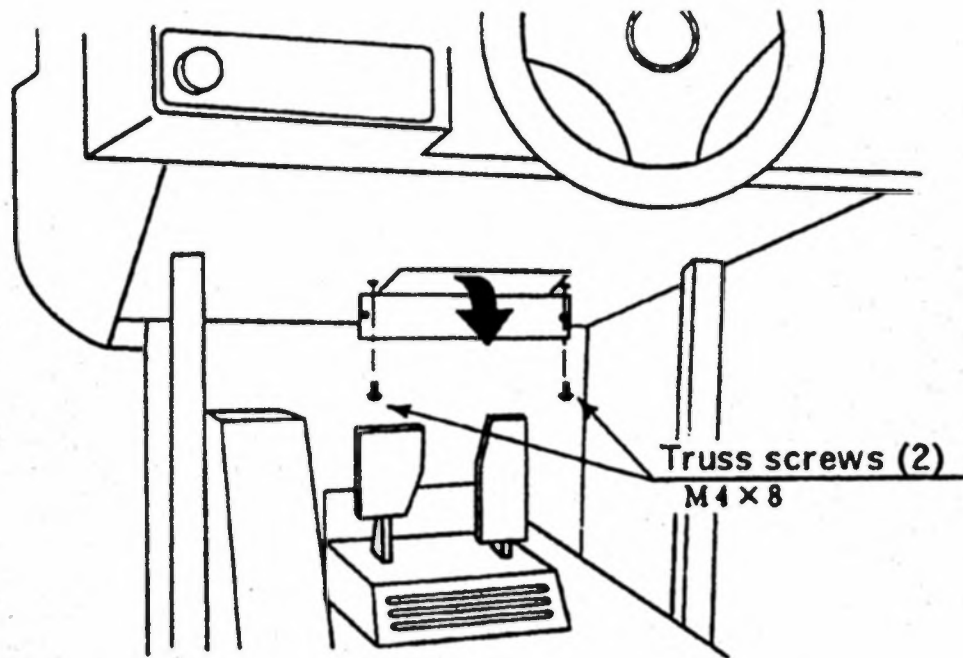

NANAO monitor: 2 0 0 - 5 2 4 2 - 2 4 - 0 4 (24K mode)

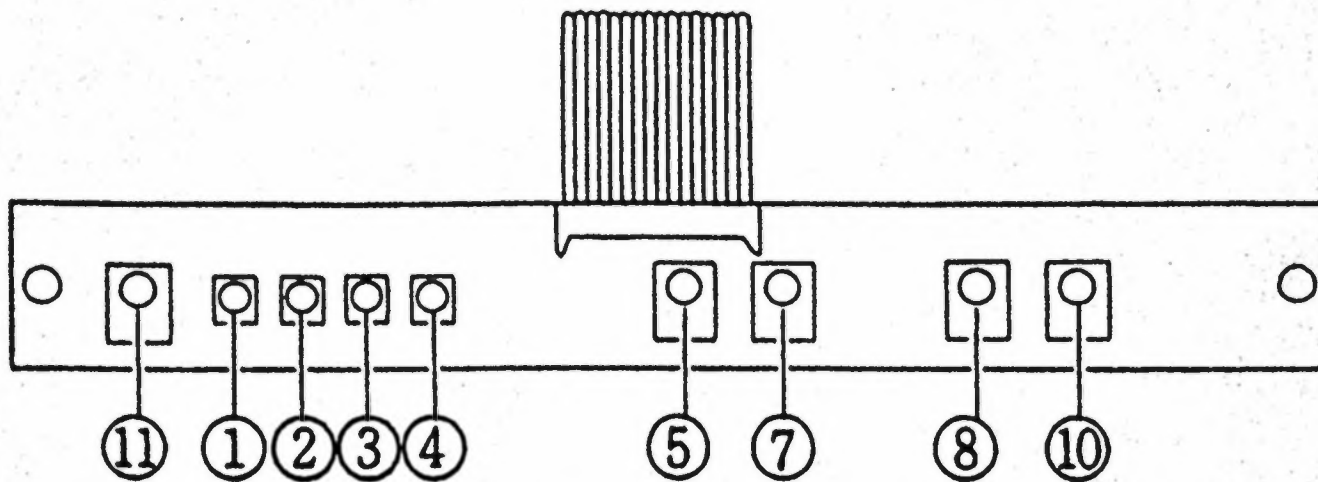

SANWA monitor: 2 0 0 - 5 2 4 3 - 2 4 (24K mode)

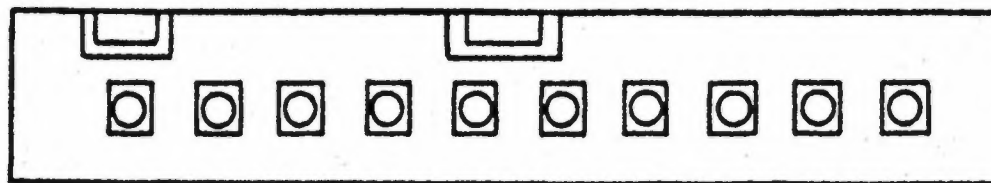

①	②	③	④	⑤	⑥	⑦	⑧	⑨	⑩
R GAIN	G GAIN	B GAIN	BRIGHT	H SIZE	H HOLD	H POSI	V SIZE	V HOLD	V POSI

- ① R-GAIN
- ② G-GAIN ..... Controls colors.
- ③ B-GAIN
- ④ BRIGHT ..... Controls screen brightness.
- ⑤ H. SIZE ..... Controls horizontal screen size.
- ⑥ H. HOLD ..... Provides horizontal synchronization, i.e., controls right/left hold.
- ⑦ H. POSI ..... Controls horizontal display position on screen.
- ⑧ V. SIZE ..... Controls vertical screen size.
- ⑨ V. HOLD ..... Provides vertical synchronization, i.e., controls up-down hold.
- ⑩ V. POSI ..... Controls vertical display position on screen.
- ⑪ CONTRAST .... Adjusts image contrast.

## 13. REPLACEMENT OF FLUORESCENT LAMP



- When performing the work, be sure to turn power off. Working with power on can cause an electric shock or short circuit accident.
- The Fluorescent Lamp, when it gets hot, can cause burns. Be very careful when replacing the Fluorescent Lamp.



To perform work safely and securely, be sure to prepare a step which is in a secure and stable condition. Not using a step or using an unstable step can cause violent falling down accidents.

### 13 -1 REPLACEMENT OF FLUORESCENT LAMP

- ① Take out the 3 Tamperproof screws from the rear of the billboard.
- ② Be sure to disconnect all connectors conected to the Marquee assembly before removing the Billboard and/or performing work.
- ③ Take out the two screws which secure the lower billboard plate mask and remove billboard

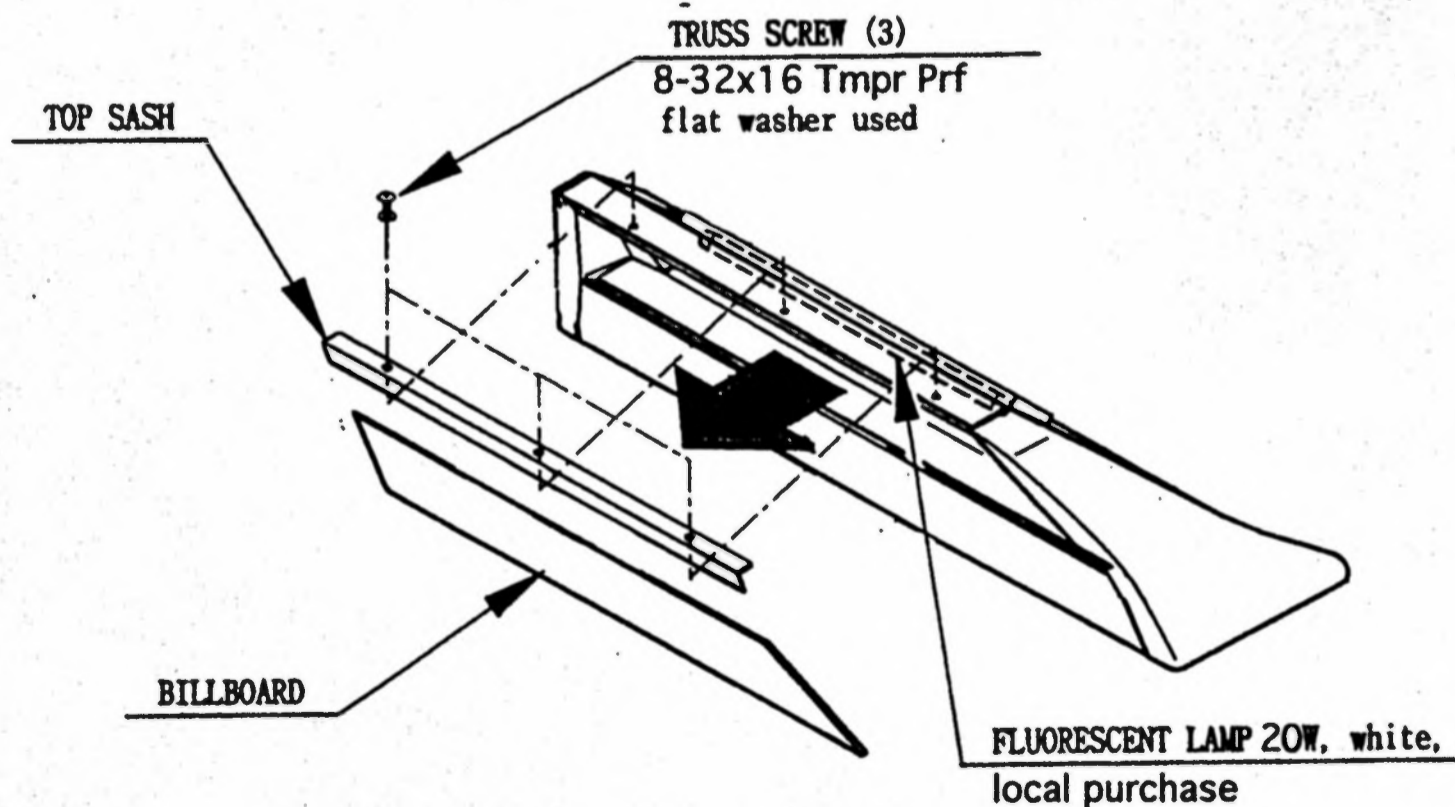

# 14. PERIODIC INSPECTION TABLE

The items listed below require periodic check and maintenance to retain the performance of this machine and ensure safe operation.



**WARNING!**

- Be sure to check once a year to see if Power Cords are damaged, the plug is securely inserted, dust is accumulated between the Socket Outlet and the Power Plug, etc. Using the product with dust as is accumulated can cause a fire or electrical shock.
- Periodically once a year, request the place of contact herein stated or the Distributer, etc. where the product was purchased from, as regards to the interior cleaning. Using the product with dust as is accumulated in the interior without cleaning can cause a fire or short circuit accident. Note that cleaning the interior parts can be performed on a pay-basis.

	Item	Interval	Reference
CABINET	Check Adjusters' contact with surface.	Daily	4
HANDLE MECHA	Check lamp.	Monthly	8
	Check VOLUME VALUE.	Monthly	8
	Check ADJUST GEAR engagement.	Trimonthly	9
	Greasing of GEAR.	Trimonthly	9
ACCEL. & BRAKE	Check VOLUME value.	Monthly	10
	Check ADJUST GEAR engagement.	Trimonthly	10
	Gear and Spring portion greasing.	Trimonthly	10
SHIFT LEVER	Check switches.	Monthly	9
COIN CHUTE TOWER	Check COIN SW.	Monthly	4
	Coin insertion test.	Monthly	11
	Cleaning of COIN SELECTOR.	Trimonthly	11
MONITOR	Check adjustments.	Monthly or when moving.	12
	Cleaning of CRT surfaces.	Weekly	12
SEAT	Antistatic measures	Bimonthly	Next page
	Applying grease to Seat Rail	Trimonthly	
GAME BD	MEMORY TEST.	Monthly	7
	Check settings.	Monthly	7
Cabinet surfaces	Cleaning	As occasion arises.	Next page
INTERIOR	Cleaning	Annually	See above.
POWER SUPPLY PLUG	Inspection and cleaning		

**CLEANING CABINET SURFACES**

If the cabinet is badly stained, use a cloth which is dipped in the chemical detergent liquid diluted with water and then squeezed dry. Do not use thinner, benzine, alcohol or chemical dustcloth as these can damage Cabinet surfaces.

**SEAT (Greasing to Seat Rail Portion)**

Move the Seat to the rearmost portion and apply spray greasing to the portion shown at the right once every 3 months by using NOK KLUBER L60 or GREASE MATE SEGA PART No. 090-0066. After greasing, move seat a few times forward and backward so as to allow the grease to be applied all over uniformly. Be sure to wipe grease which attaches to the surfaces of the PROTECT RUBBER on the seat Rail, or any excess grease.

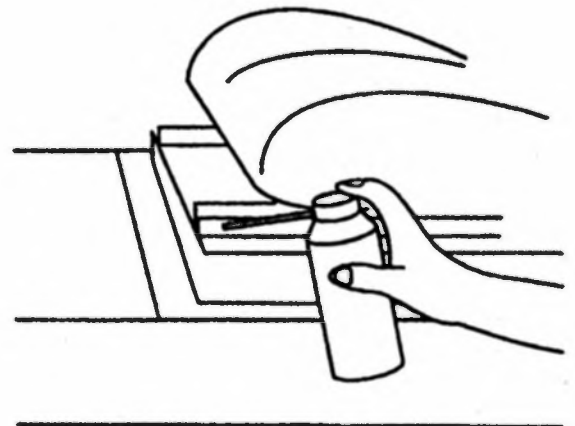

## 15. TROUBLESHOOTING

Should trouble occur, first check connector connections.

PROBLEMS	CAUSE	COUNTERMEASURES
With Main SW ON, no activation	Power is not supplied. Power supply/voltage is not correct. AC main fuse causes the power to be cut off due to momentary overload.	Plug in correctly Make sure that power supply/voltage is correct. Check fuse. Remove the cause of overload and replace fuse
Operation is unsatisfactory	Volume Setting Failure Poor mesh of V.R. gear. Spring failure due to secular change of Accelerator and Brake Mecha.	Perform Volume setting Adjust or replace V.R. Adjust Gear mesh.. Replace the Spring.
Irregular sound emitted from inside Rear Cabinet	Greasing to gear mesh portion is not satisfactory, or extraneous matter mixed in.	Apply greasing or eliminate extraneous matter.
The color of the image on PROJ. screen is incorrect.	Connector connections are defective.	Check the connection for the RGB and SYNC connectors of the PROJ. TERM. BD and VPM BUFFER BD.
The image on PROJ. screen has color deviation.	Affected by the magnetic field of installation location.	Make CONVERGENCE adjustment. (Refer to Section 12.)
No sound is emitted.	Sound Volume adjustment is not appropriate. Sound BD and speaker are malfunctioning.	Adjust sound volume. (see Section 7). Perform sound test to find and replace defective parts.(Refer to Section 7).
NETWORK check will not finish.	Communication cable's connection failure.	Perform V.R. setting, Adjustment.
Communication play is not possible.	Communication cable's connection failure. Communication Play setting is wrong.	Check for Communication cable disconnection Correctly set in test mode.
No sound from Cockpit.	In correct Cabinet Type Setting.	Correct Cabinet Type Setting.
The Fluorescent lamp does not light up.	The Fluorescent tube is burnt out.	Replace the Fluorescent tube (Refer to Section 11).
Shift operation is not satisfactory in Manual transmission.	Shift SW malfunctioning.	Replace SW

## 16. GAME BOARD



- In order to prevent an electrical shock, be sure to turn power off before performing work by touching the interior parts of the product.
- Be careful so as not to damage wirings. Damaged wiring can cause an electric shock or short circuit accident.



Do not expose the Game BD, etc. without a good reason. In this product, setting changes are made during the test mode. The Game BD need not be operated. Use the Game BD, etc. as is with the same setting made at the time of shipment.

### 16 -1 REMOVING THE GAME BOARD

To replace the IC Board or to change dip switch settings, take out the IC board using the following procedure;

- ① Turn main switch off.
- ② Unlock the base, and remove the 2 truss screws from the side of the base.
- ③ Turn the knob to unlock. The seat can be inclined in the direction shown. When inclining the seat, be careful not to damage seat parts. Carefully rest the backrest portion of the seat on the ground.
- ④ If necessary, protect the seat from damage by using a cloth or blanket on the floor.
- ⑤ Take off the 3 screws to remove the case lid. The game board is inside the shield case.
- ⑥ Take off a total of 4 screws from both sides with the seat being in an inclined state and remove the base lid F.  
Removing base lid F allows the Elec Base to be seen.

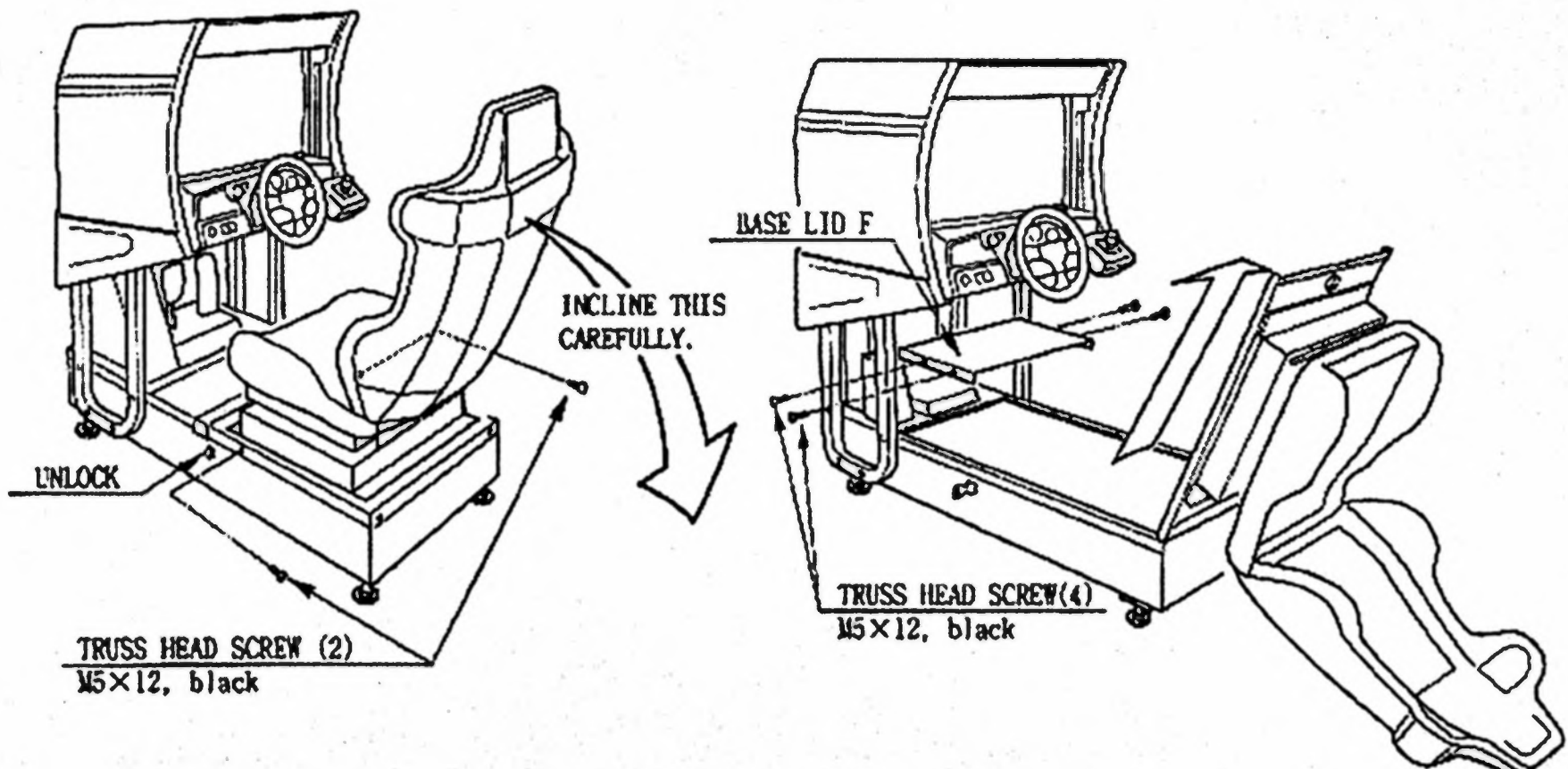

## 16 - 2 REPLACEMENT OF FUSE



**WARNING!**

- In order to prevent an electric shock, be sure to turn power off before performing work by touching the interior parts of the product.
- Be careful so as not to damage wirings. Damaged wiring can cause an electric shock or short circuit accident
- After eliminating the cause of the blowing of fuse, replace the fuse.  
Depending on the cause of the fuse blowing, using the fuse as is blown can cause generation of heat resulting in fire.

Incline the Seat and remove the Base Lid to view the Base interior. The composition of the Base interior is as shown below. There is a fuse on each of the Connect BD. and Motor Drive BD. When replacing the fuse, be sure to use the specified one.

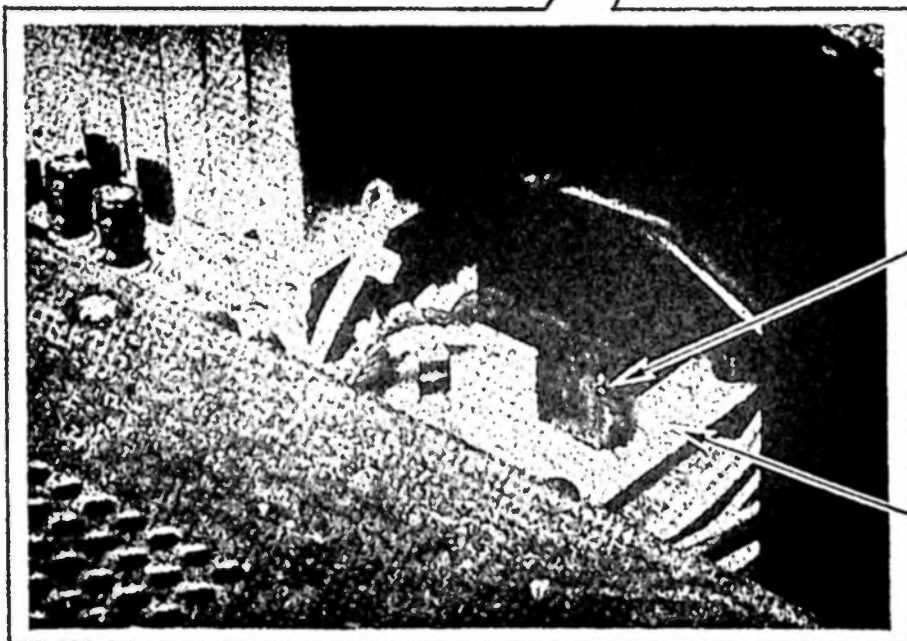
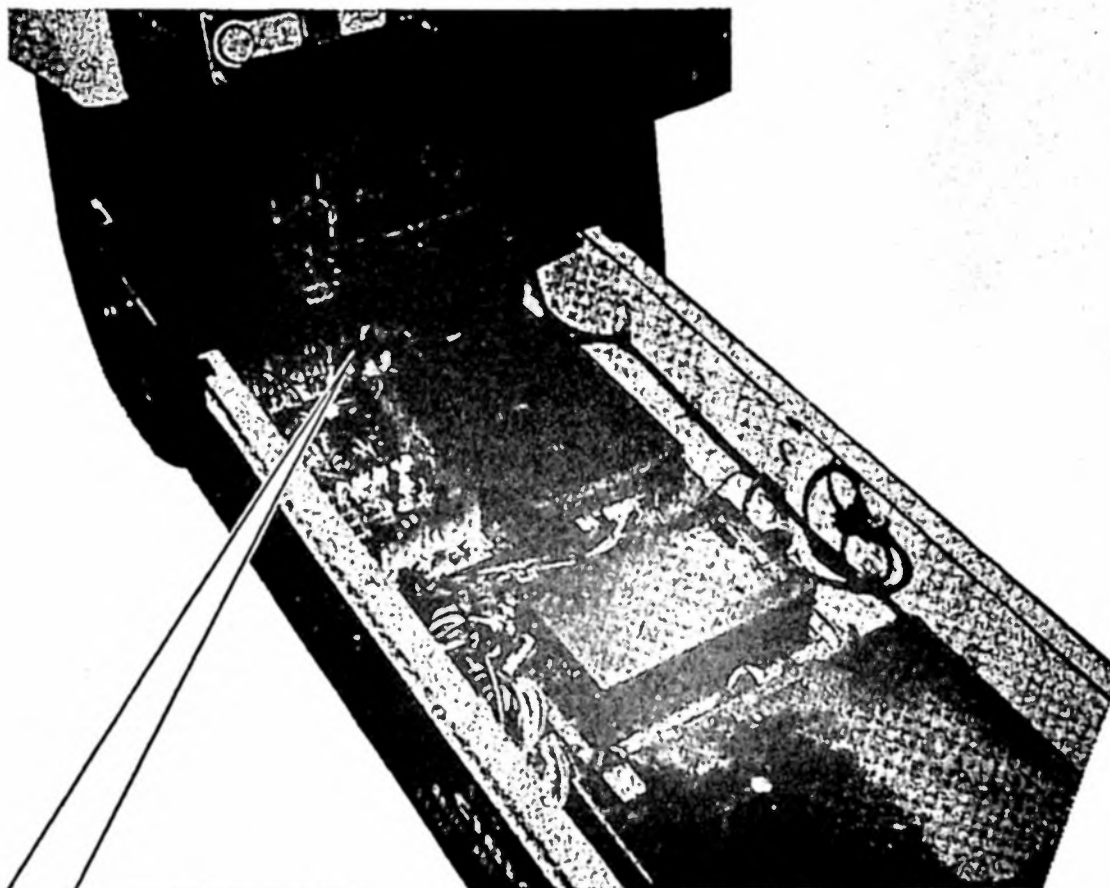

FUSE 5A  
LOCAL PURCHASE

CONNECT BD

# 16 - 3 COMPOSITION OF GAME BOARD



Ensure that the DIP SW setting is performed as designated as designated. Failure to observe thisw may cause functioning not suitable for tyhe operation, or mal-functioning.

ASSY CASE NAO USA (840-0002D-01) :USA

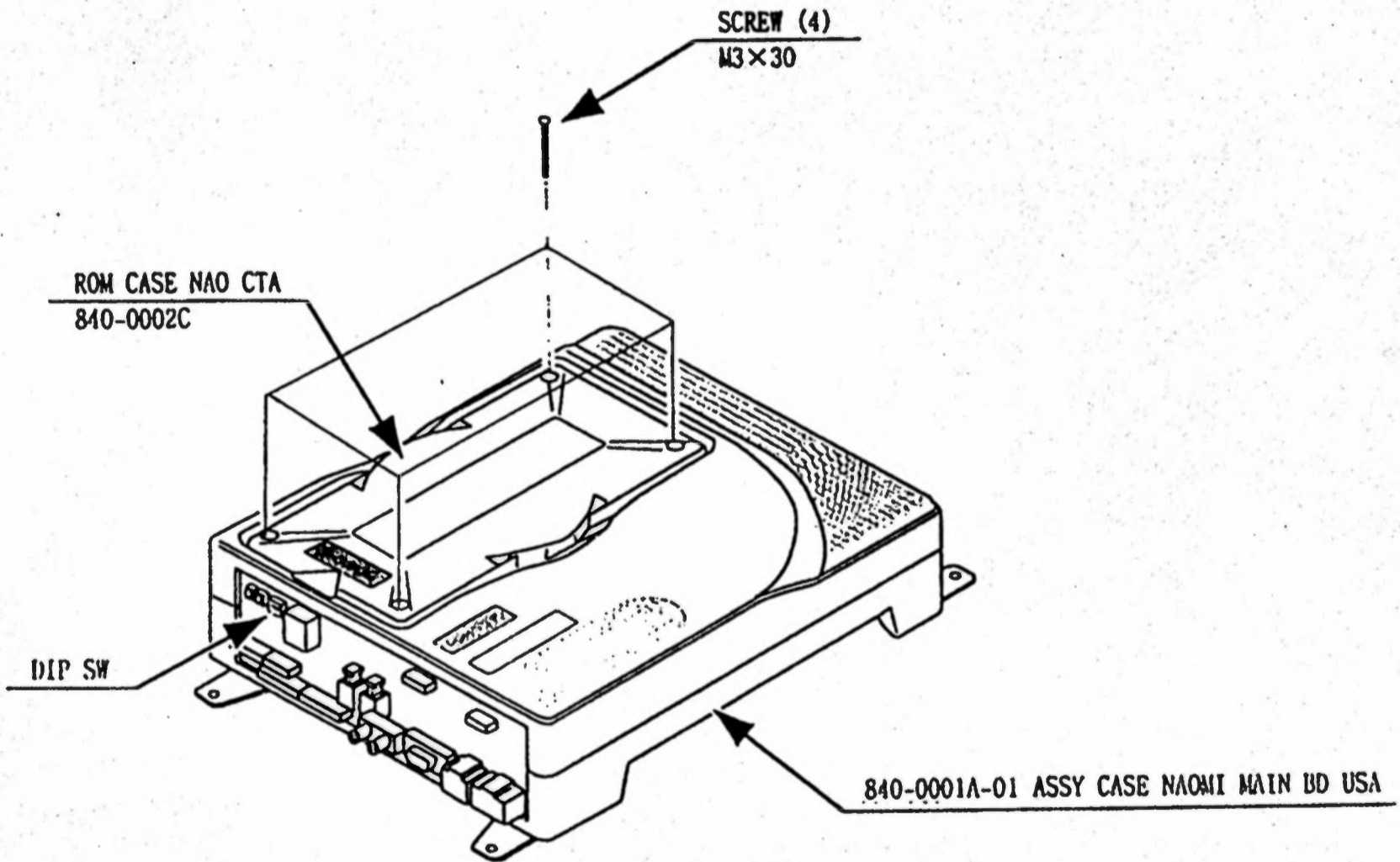

## DIP SW SETTING

IN the product, set all of the DIP SWes to OFF.

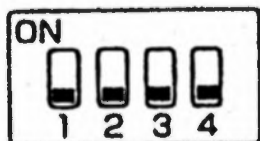

# 17. DESIGN RELATED PARTS

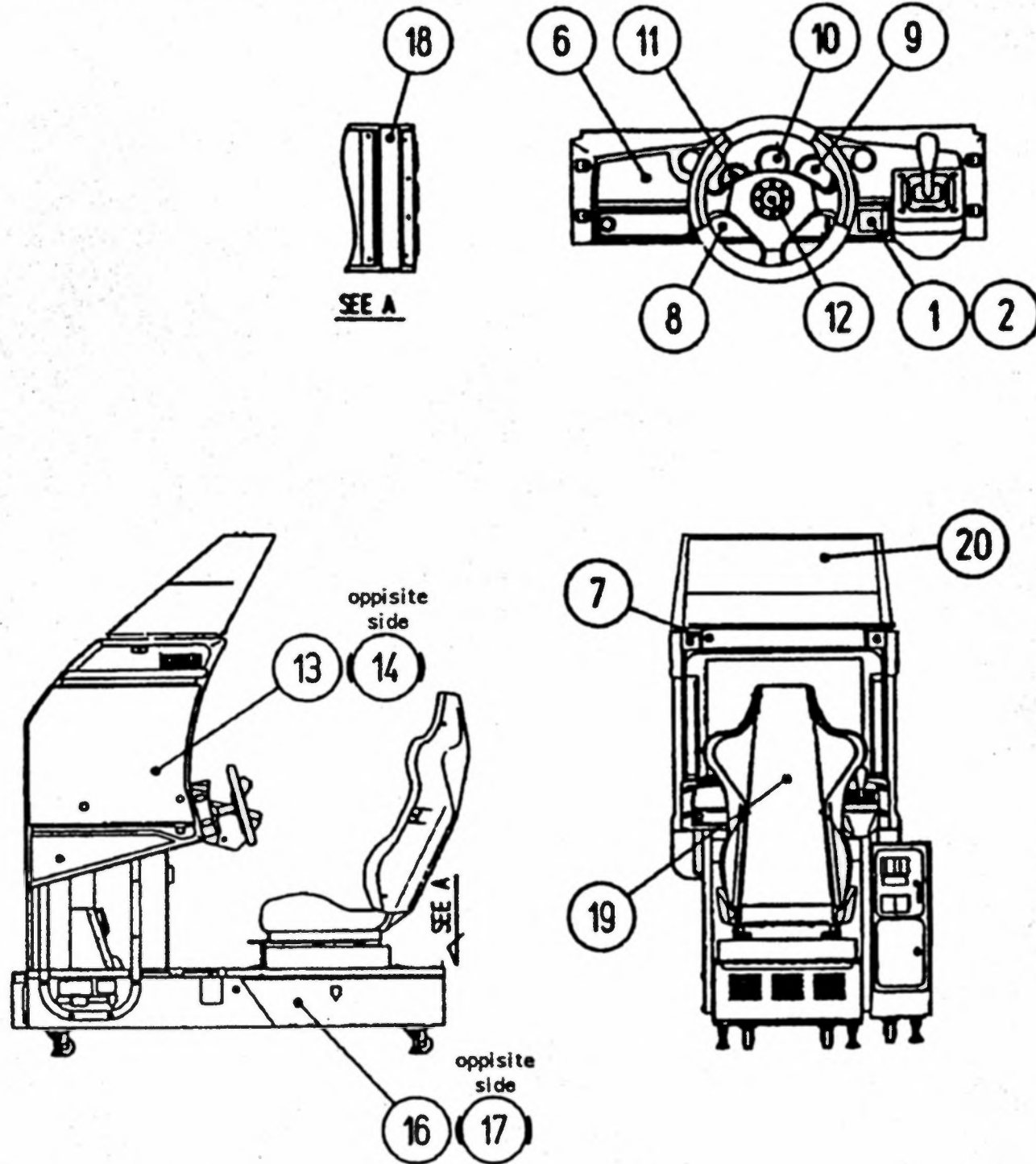

ITEM NO.	PART NO.	DESCRIPTION
1	DYN-0011	DENOMI PLATE W/O ORIGINAL
2	LOCAL PURCHASE	DENOMINATION SHEET 1 GAME
6	999-0771	STICKER INSTRUCTION SH CTA
7	999-0770	STICKER SUB INSTR SH CTA
8	SPG-1201-E	METER PANEL
9	DYN-1214-C	DESIGN PL TACO MTR TWIN
10	DYN-1214-D	DESIGN PL OIL MTR TWIN
11	DYN-1214-E	DESIGN PL WATER MTR TWIN
12	SPG-2002	STEERING EMBLEM
13	999-0773	STICKER MONITOR COVER L CTA
14	999-0772	STICKER MONITOR COVER R CTA
16	999-0769	STICKER MAIN BASE L CTA
17	999-0768	STICKER MAIN BASE R CTA
18	999-0767	STICKER MAIN BASE C CTA
19	999-0766	STICKER SEAT REAR CTA
20	999-0761	MARQUEE PLEX CRAZY TAXI

# 18. PARTS LIST

## TOP ASSY CRAZY TAXI

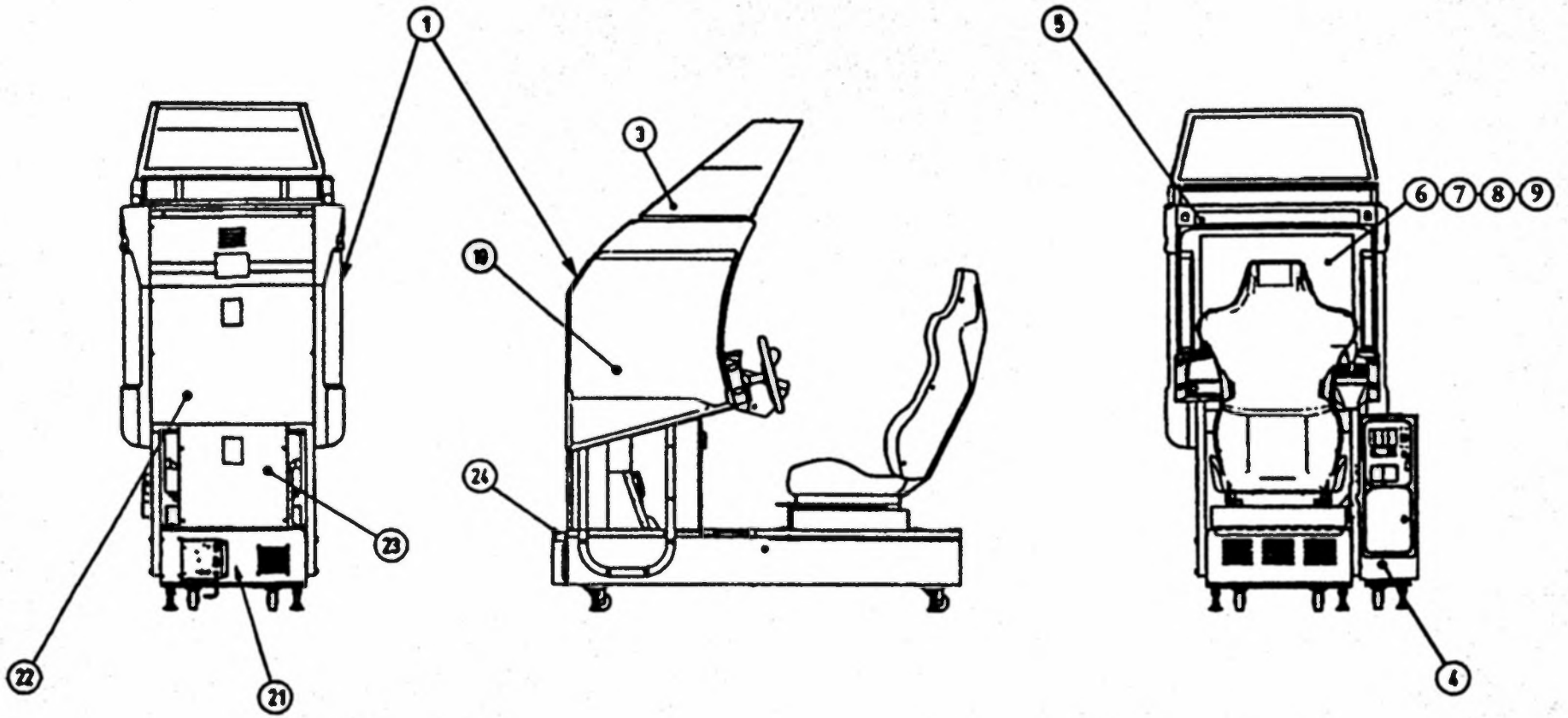

TORQUE: M8 195kgf·cm  
Under M4(M SCR) 10kgf·cm

ITEM NO.	PART NO.	DESCRIPTION
1	DRT5-10001	ASSY COCKPIT 1P CTA
3	999-0774	ASSY BILLBOARD CTA
4	SPG-0300	ASSY COIN CHUTE TOWER
5	999-0770	SUB INSTR SH CTA ENG
21	SPG-0006	AC COVER
22	INY-0004	BACK LID INY
23	DYN-0008	BACK LID B
24	DYN-0009	HOLE LID

ASSY BILLBOARD STD (999-0774)

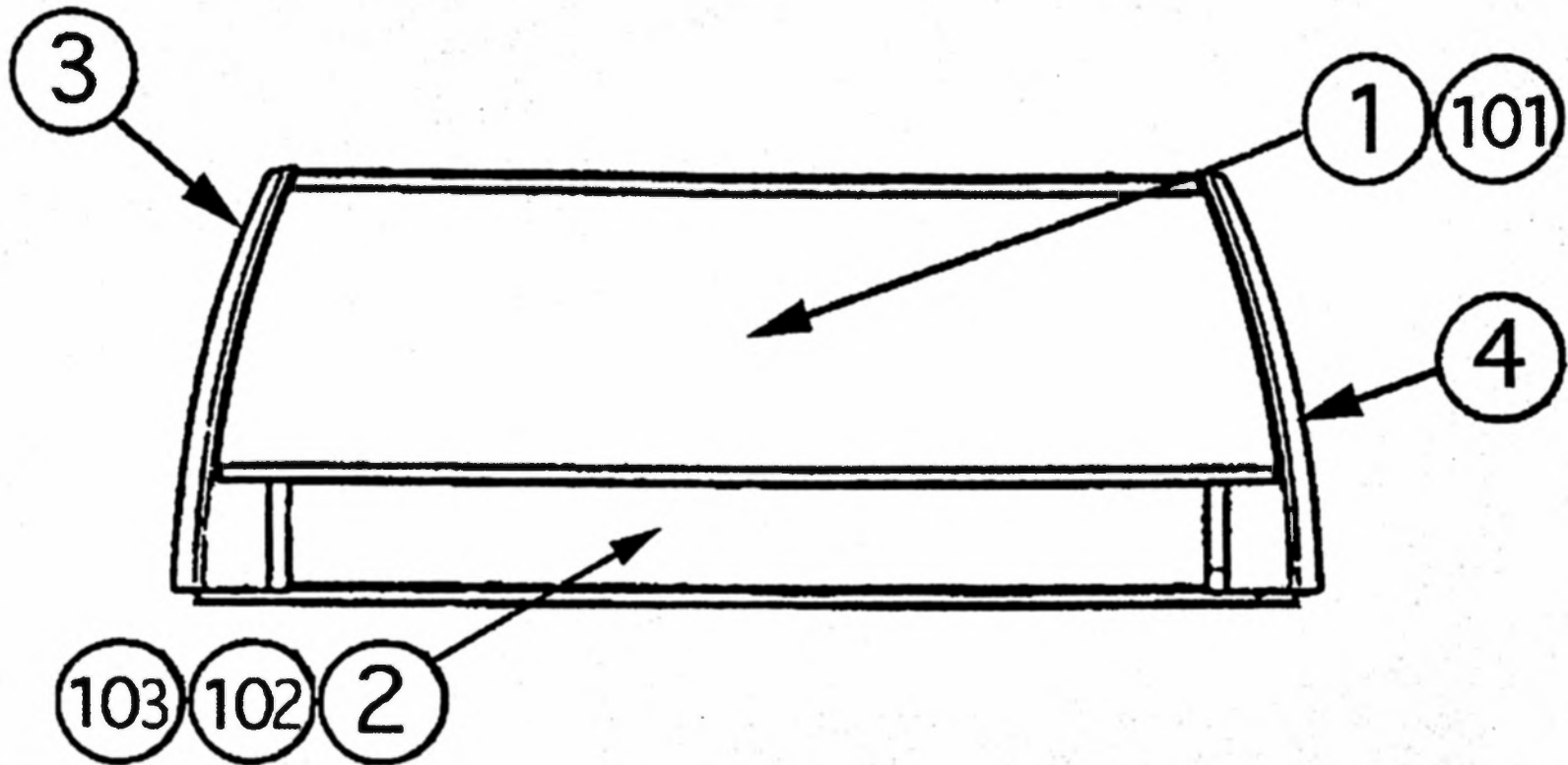

ITEM NO.	PART NO.	DESCRIPTION
1	999-0761	MARQUEE PLEX CRAZY TAXI
2	999-0733	LOWER MARQUEE GRILL
3	999-0731	MARQUEE COVER L
4	999-0732	MARQUEE COVER R
101	LOCAL PURCHASE	ASSY FL 20W EX W/CONN HIGH S
102	DRT1-0230	LAMP UNIT
103	DRT1-0240	SKT UNIT

ASSY LAMP UNIT (DRT1-0230)

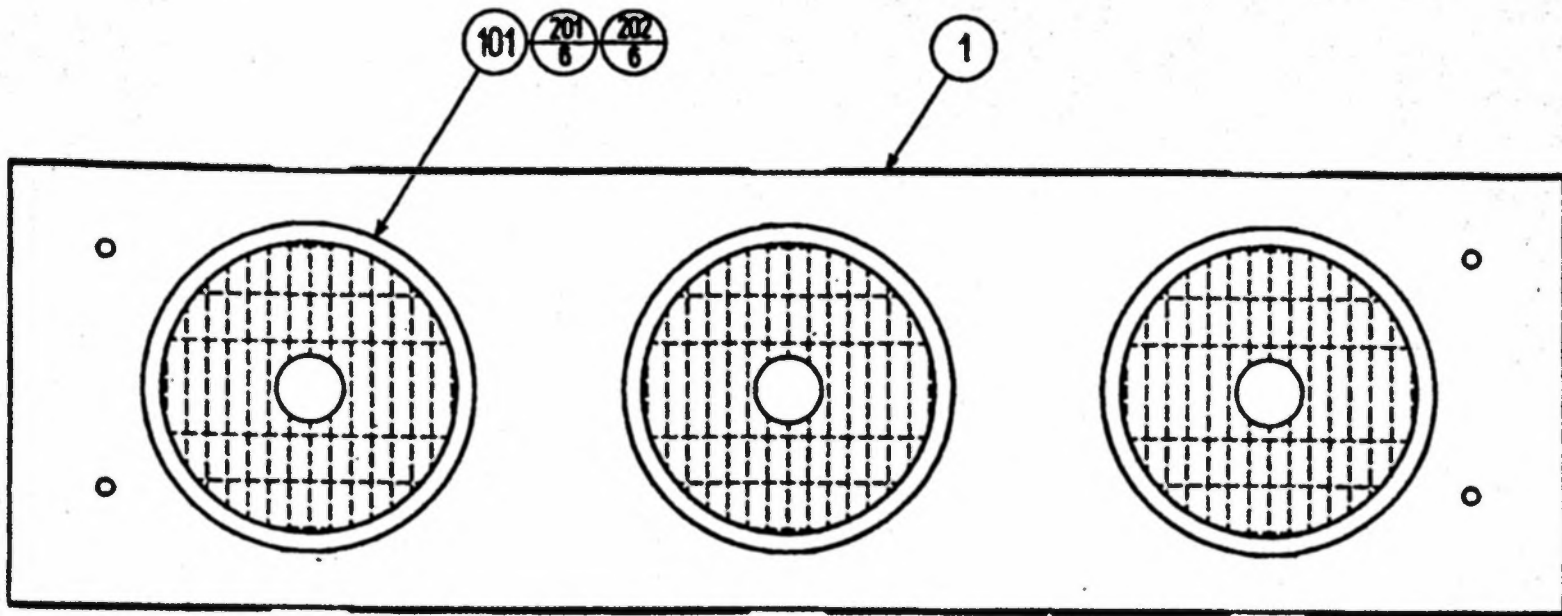

ITEM NO.	PART NO.	DESCRIPTION
1	DRT5-0231	LAMP HOLDER
101	999-0734	ASSY YELLOW LAMP COVER
201	000-T00408-0C	M SCR TH CRM M4X8
202	068-441616-0C	FLT WSHR CRM 4.4-16X1.6

ASSY SKT UNIT (DRT1-0240)

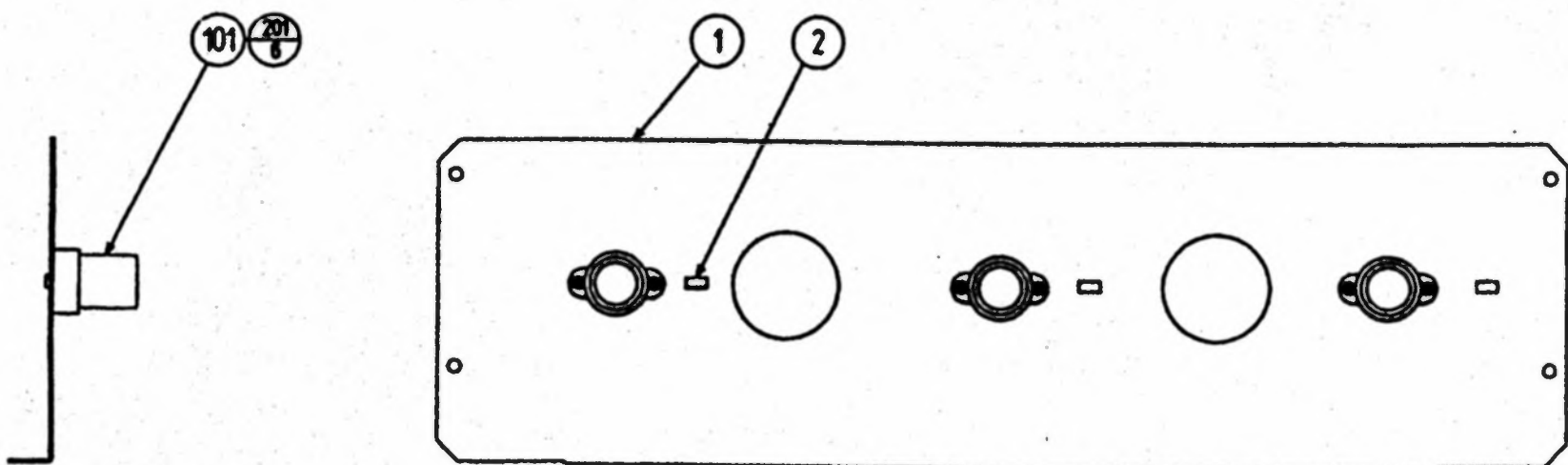

ITEM NO.	PART NO.	DESCRIPTION
1	DRT5-0241	SKT HOLDER
101	LOCAL PURCHASE	BULB SKT
201	000-P00320-S	M SCR PH W/S M3X20

ASSY COINCHUTE TOWER (DUT5-0300)

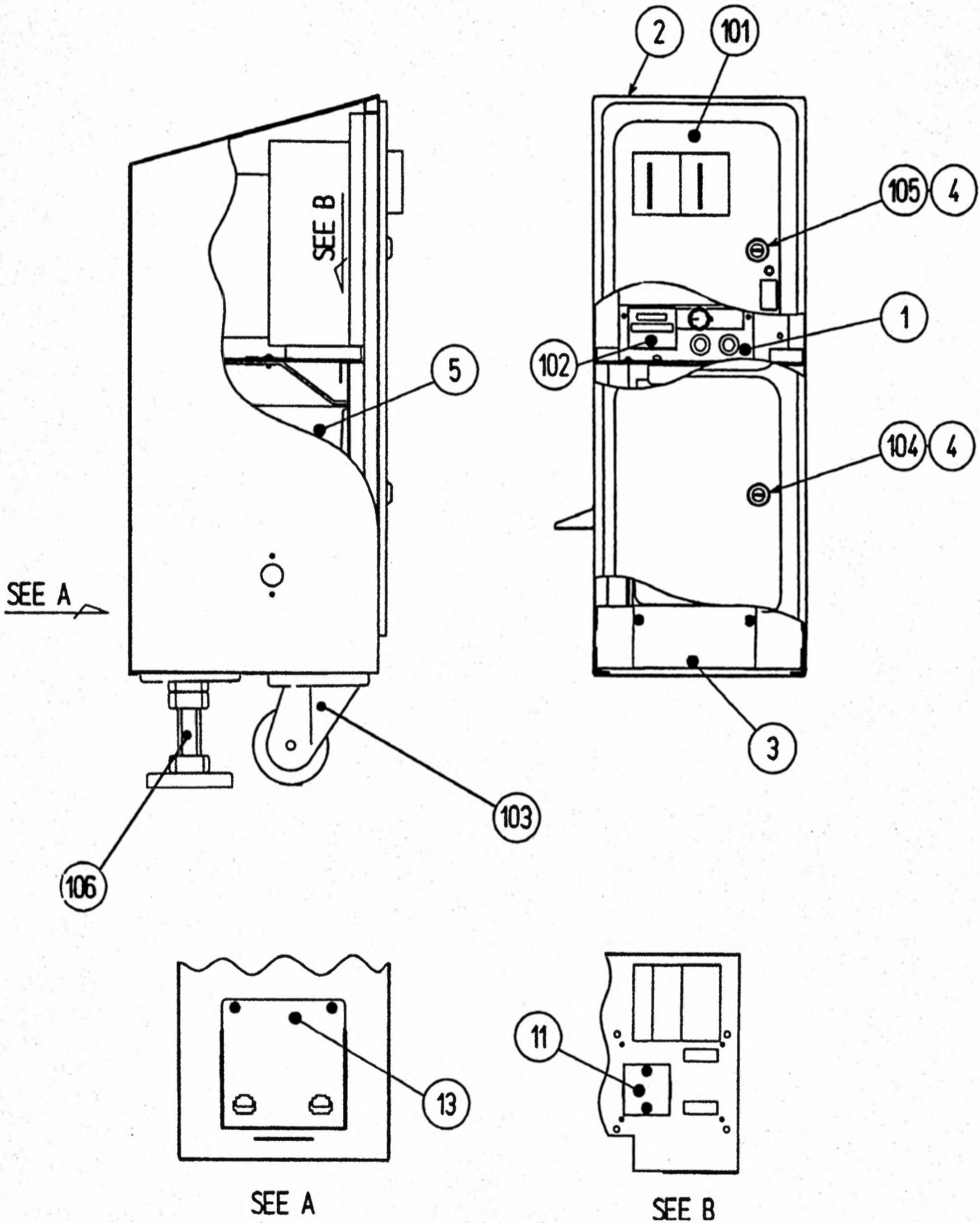

ASSY COINCHUTE TOWER (DUT5-0300)

ITEM NO.	PART NO.	DESCRIPTION
1	SPG1-0350	SW UNIT
2	SPG1-0301	COIN CHUTE TOWER
3	DYN-0302Y	COIN METER BRKT
4	DP-1167	TNG LKG
5	BOX-CASH	CASH BOX
10	DYN-0305	TOWER BRKT
11	105-5202	HOLE COVER
12	SPG-0302	WIRE BOX
13	SPG-0303	WIRE BOX LID
101	92-1003-05*	ASSY C.C. 2DR
102	220-5412	MAG CNTR W/CONN
103	999-0175	CASTER 2 1/2"
104	220-5574	CAM LOCK W/KEYS
105	220-5575	CAM LOCK MASTER W/O KEY
106	999-0176	LEG LEVELER

\* This coin door is produced by Coin Controls and can be ordered through your local distributor.

SW UNIT (SPG5-0350)

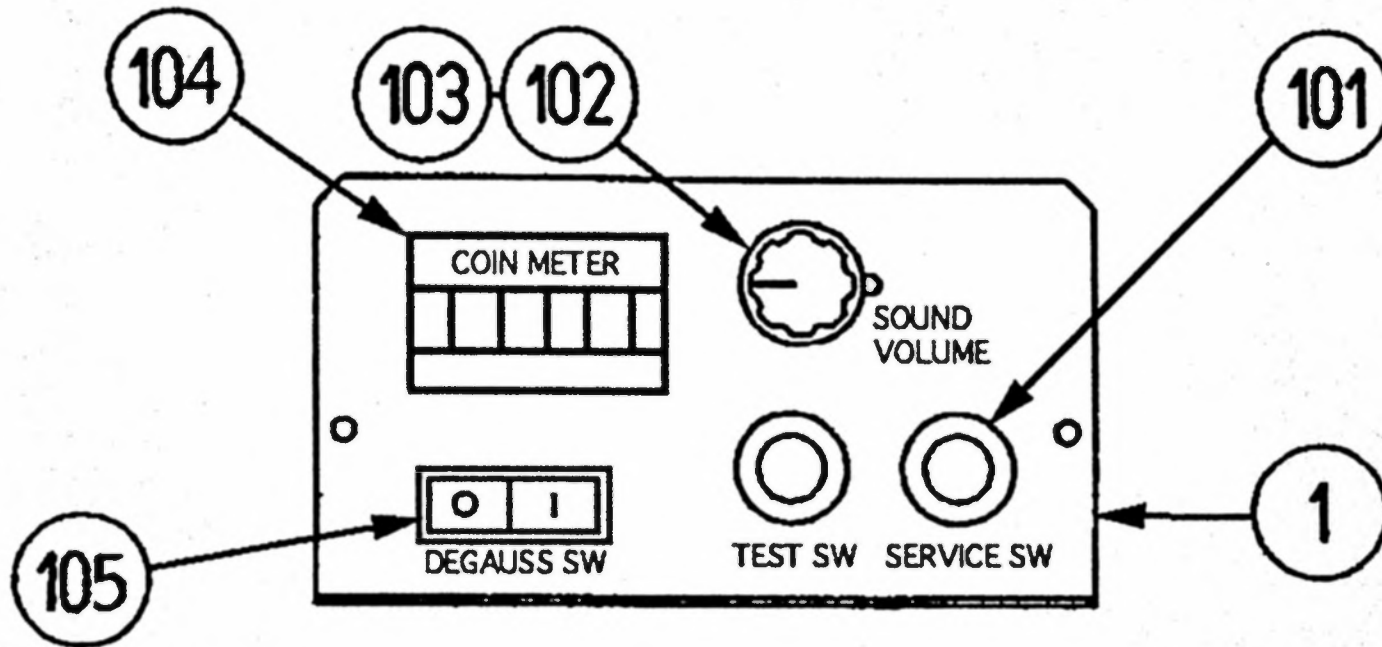

ITEM NO.	PART NO.	DESCRIPTION
1	SPG5-0351	SWITCH BRKT
101	509-5028	SW PB 1M
102	220-5179	VOL CONT B-5K OHM
103	601-0042	KNOB 22MM
104	220-5412	MAG CNTR W/CONN
105	509-5453-91-V-B	ROCKER SWJ8 V-B

AC UNIT (DRT1-0400)

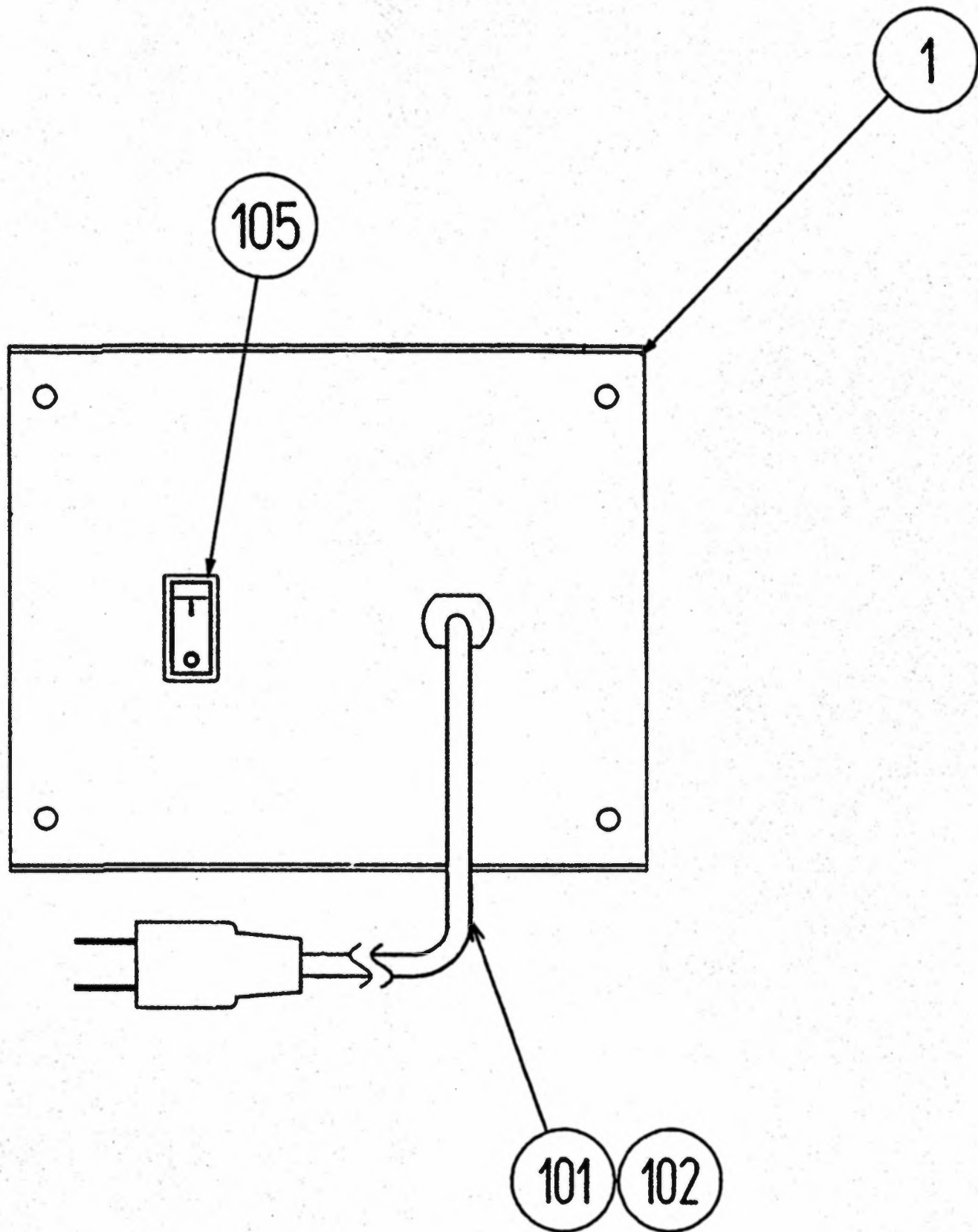

TEM NO.	PART NO.	DESCRIPTION
1	SPG1-0401	AC BRKT
101	600-5843-25	CA & PLUG ASSY 15A W/F-L=2.5M
102	280-5134-6N34	BUSHING STRAIN RELIEF 6N34
105	509-5453-91-V-B	SW ROCKER J8 V-B

ASSY MONITOR COVER R 1P (DRT5-1045)

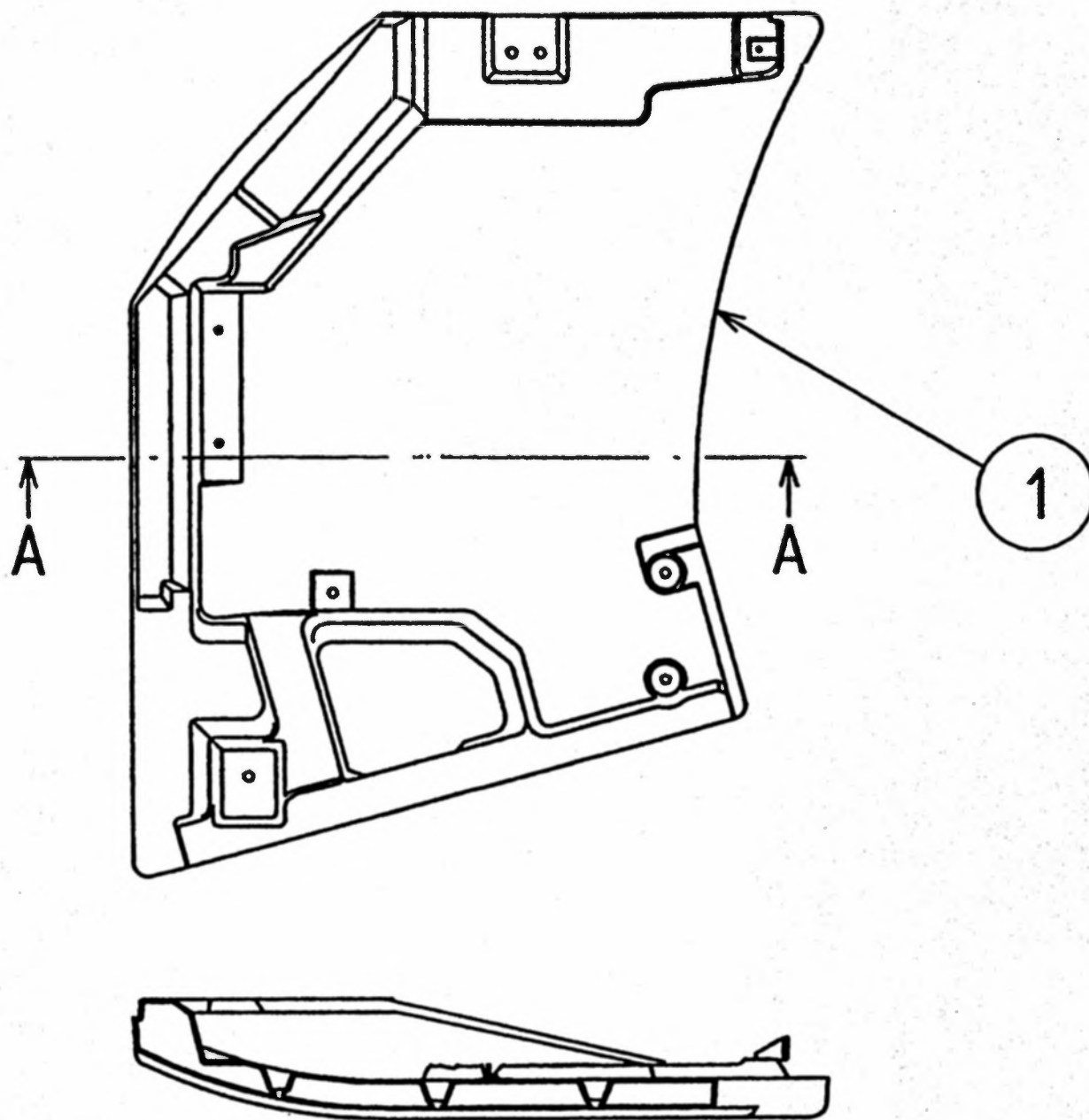

SECTION A-A

ITEM NO.	PART NO.	DESCRIPTION
1	DRT5-1046	COVER PANEL R 1P

ASSY MONITOR COVER L 1P (DRT5-1030)

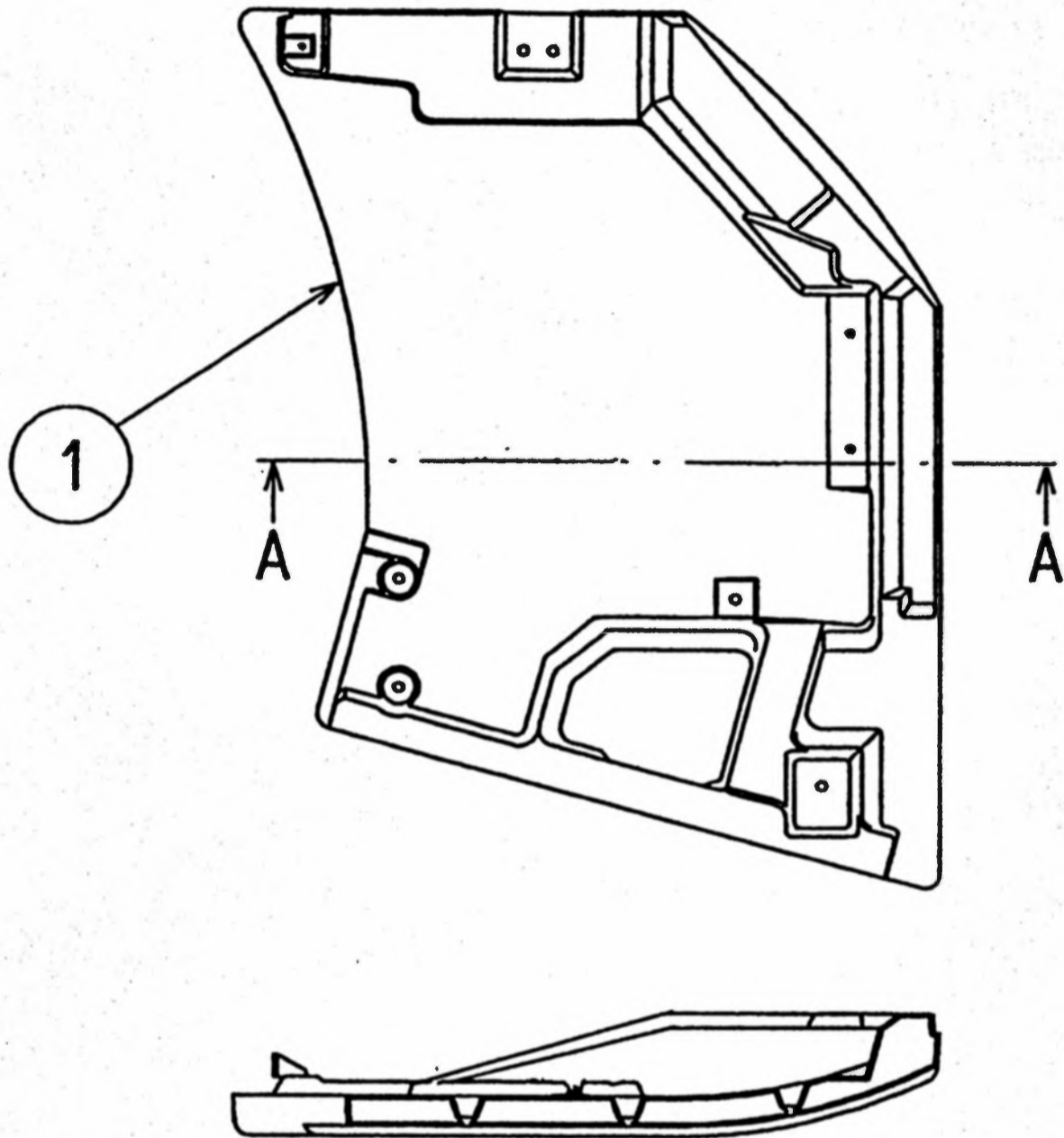

SECTION A-A

ITEM NO.	PART NO.	DESCRIPTION
1	DRT5-1031	COVER PANEL L 1P

ASSY SPEAKER (SPG-1100)

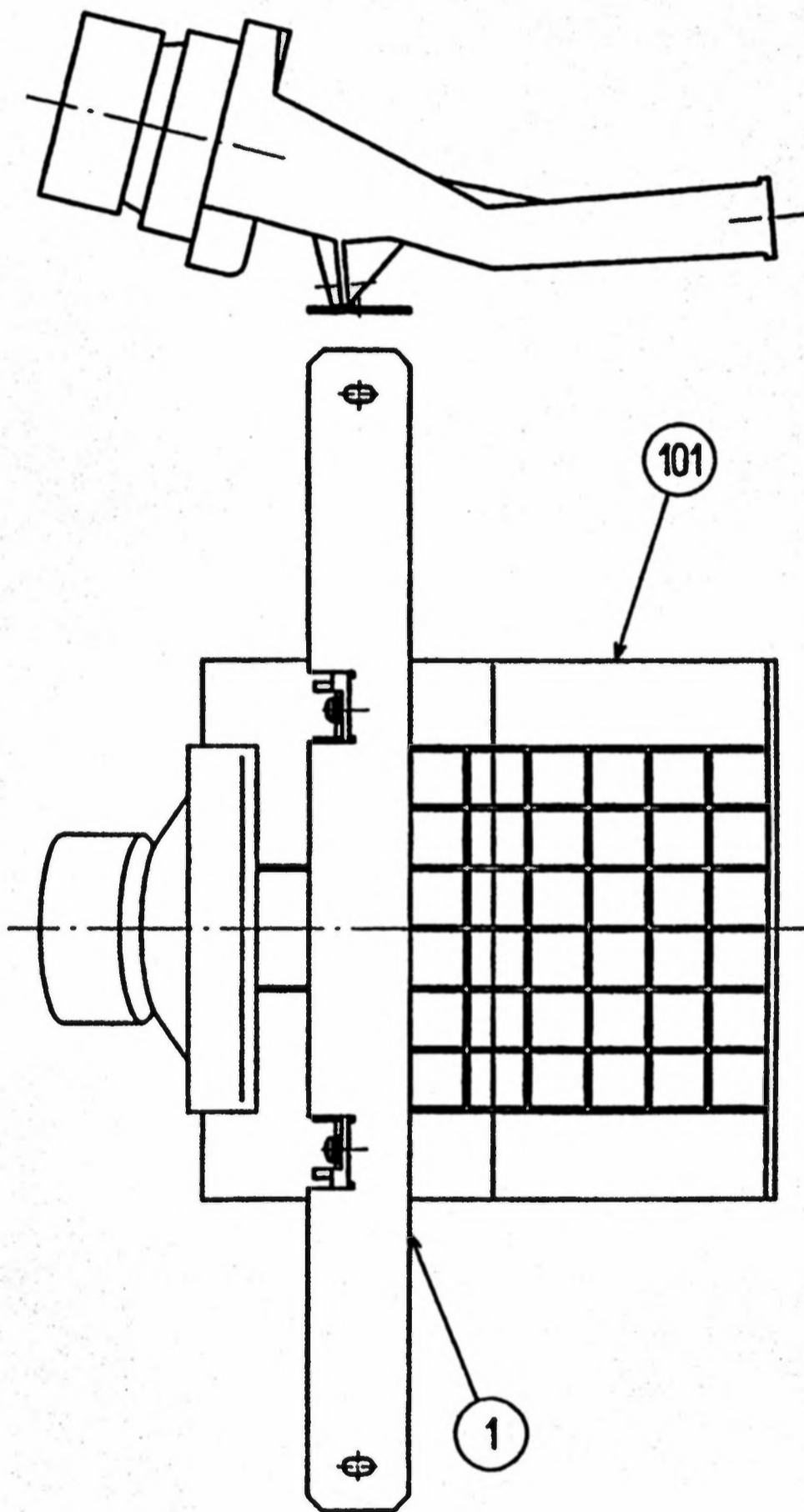

ITEM NO.	PART NO.	DESCRIPTION
1	INY-1701	SPEAKER BRKT
101	130-5159	GULL BOX SPEAKER 8OHM 5W

ASSY VIRTUAL BUTTON TWIN (DRT5-1290)

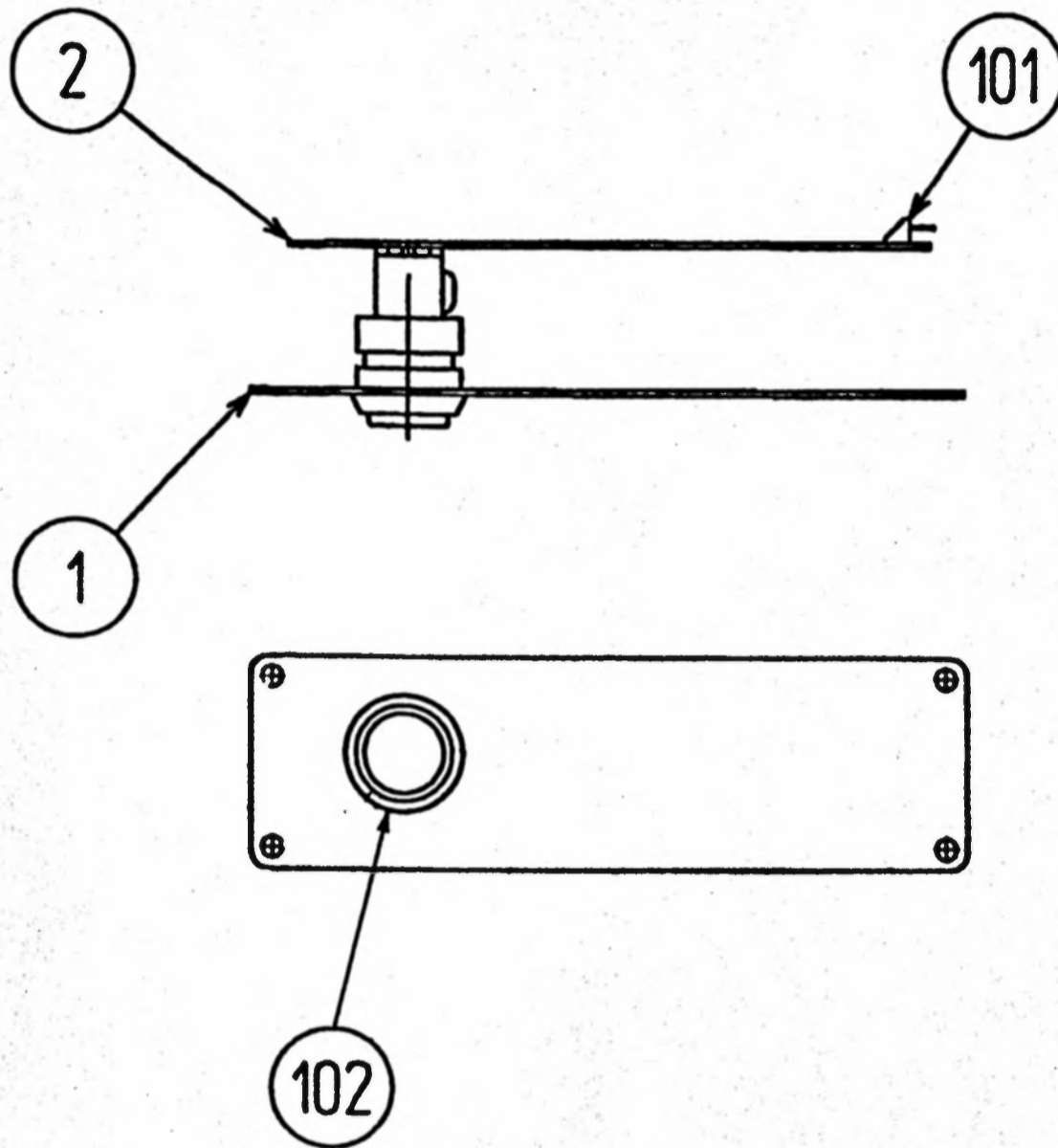

ITEM NO.	PART NO.	DESCRIPTION
1	DRT5-1291	VR BUTTON BRKT
2	171-6478B	PC BD LIGHTING SW
101	212-5205-12	CONN JST M 12P RTA
102	509-5560-Y	PB SW W/L 6V 1L Y

ASSY BASE BOX (DRT1-1500)

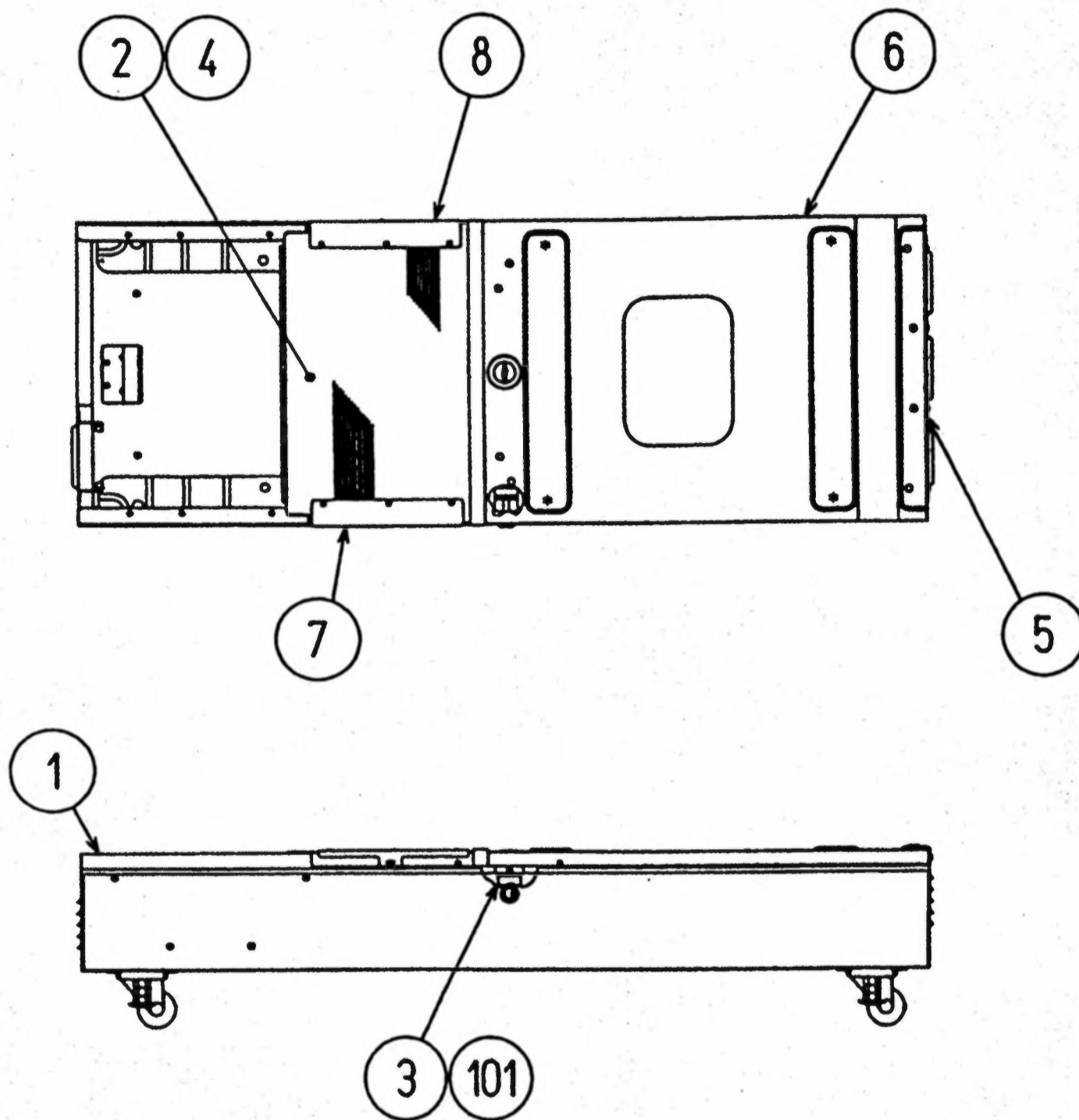

ITEM NO.	PART NO.	DESCRIPTION
1	DRT1-1501	MAIN BASE
2	DYN-2003	BASE LID F
3	DYN-2004	LOCK TNG
4	DYN-2005X	FLOOR MAT
5	DYN-2006	HINGE 480
6	DRT-1510	ASSY BASE LID R
7	DYN-2007X	LID EDGE L
8	DYN-2009X	LID EDGE R
101	220-5575	CAM LOCK MASTER W/O KEY

MAIN BASE (DRT1-1501)

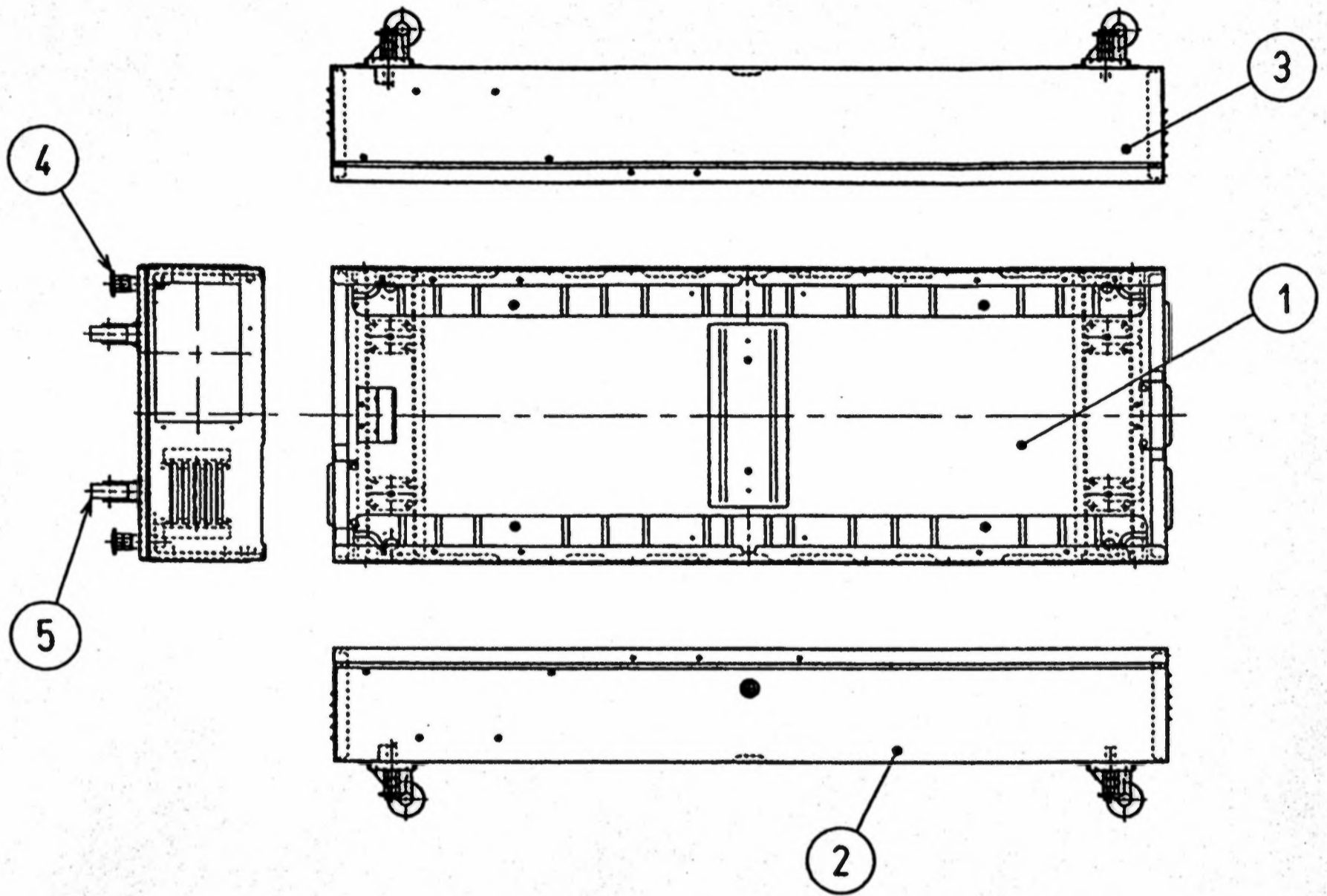

ITEM NO.	PART NO.	DESCRIPTION
1	DYN-2002X-A	MAIN BASE BLANK
2	999-0769	STICKER BASE L
3	999-0768	STICKER BASE R
4	999-0167	LEG ADJUSTER BOLT 1/2X13X3
5	999-0169	CASTER 2 1/2"

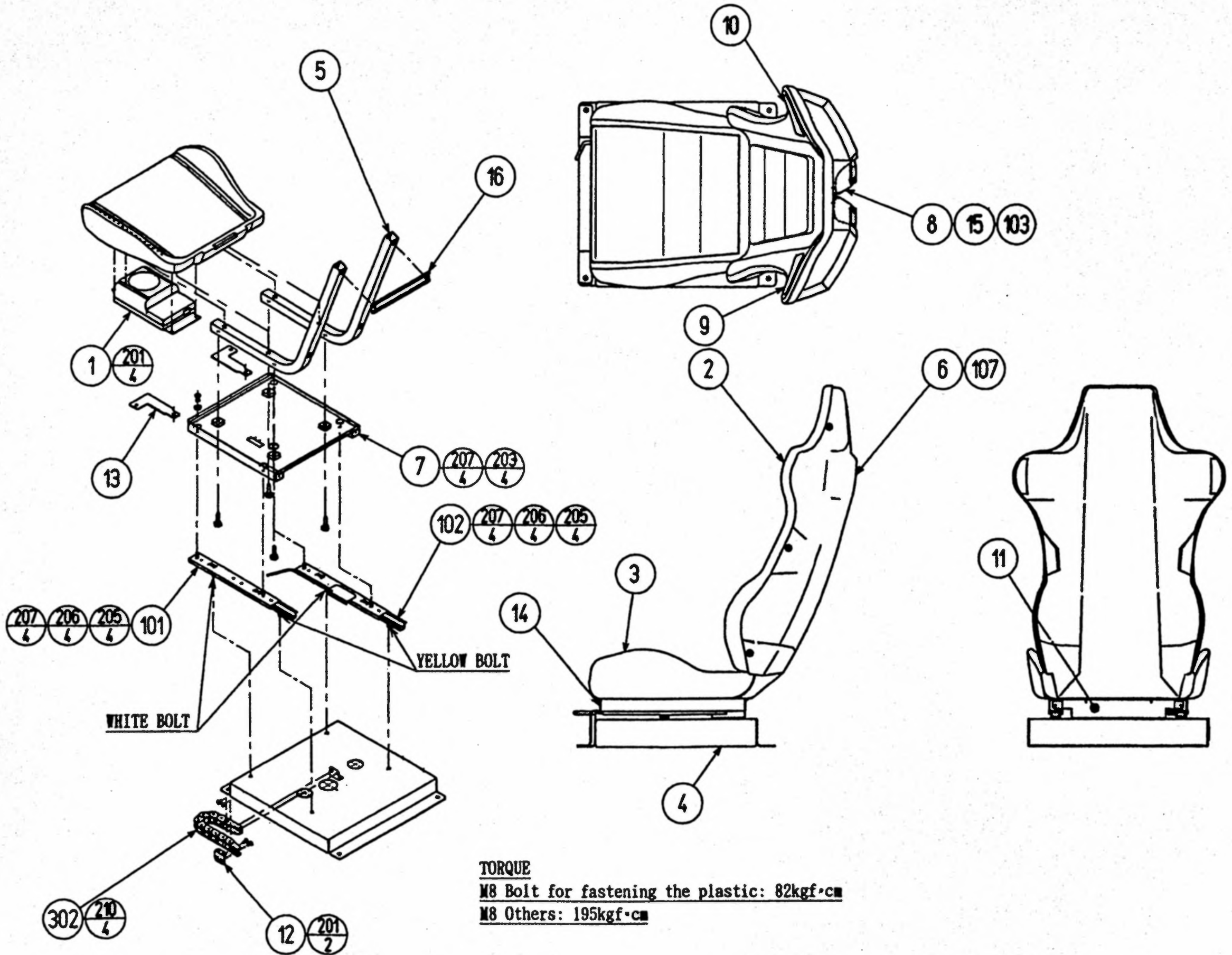

**TORQUE**  
M8 Bolt for fastening the plastic: 82kgf·cm  
M8 Others: 195kgf·cm

ASSY SEAT TWIN 1P (DRT-1600)

ITEM NO.	PART NO.	DESCRIPTION
1	SPG-1650	ASSY WOOFER
2	DRT-2202	UPPER SEAT
3	DRT-2203	LOWER SEAT
4	STC-2201	SEAT BASE
5	STC-1604	SEAT FRAME
6	DRT-1601	SEAT REAR COVER 1P
7	STC-1606	SEAT MOUNT TRAY
8	STC-1607	SP MOUNT BRKT
9	STC-1608	SPEAKER NET L
10	STC-1609	SPEAKER NET R
11	STC-1610	SAFETY GUARD
12	STC-1611	CABLE BEAR BRKT
13	STC-1612	PROTECT RUBBER
14	STC-1613	SAFETY GUARD F
15	INY-1302-B	MASK CUSHION SIDE
101	601-9059	SEAT RAIL L
102	601-9060	SEAT RAIL R
103	130-5159	GULL BOX SPEAKER 8OHM 5W
105	601-6563-188	BUSH 2.4T
106	601-6563-100	BUSH 2.4T
107	280-5297	SCRIVET 8 1K31
201	000-P00410-W	M SCR PH W/FS M4X10
203	030-000816-S	HEX BLT W/S M8X16
205	050-H00800	HEX NUT M8
206	060-S00800	SPR WSHR M8
210	000-T00616-0B	M SCR TH BLK M6X16
211	010-P00408-F	S-TITE SCR PH W/F M4x8

ASSY WOOFER (STC-1650)

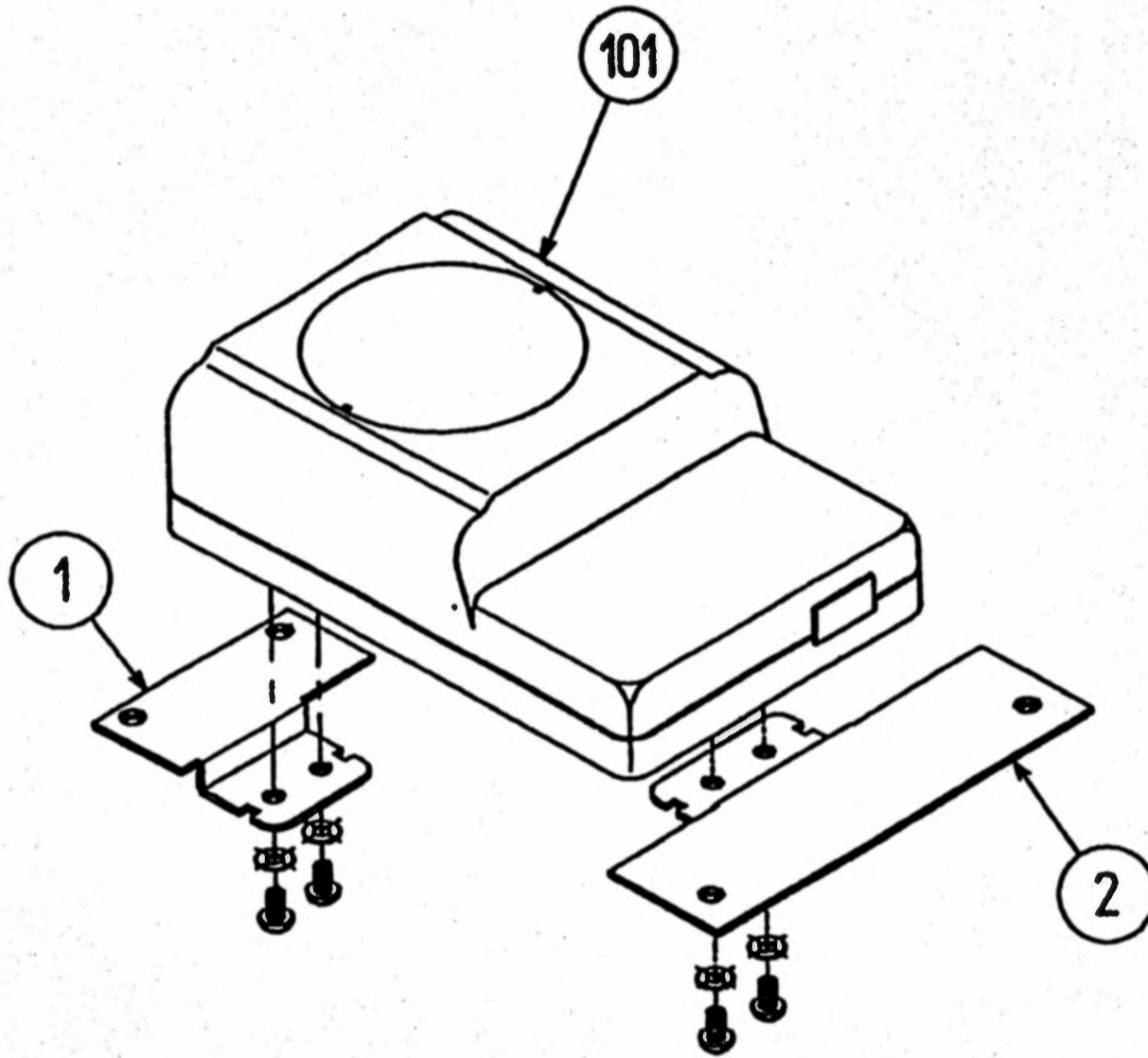

ITEM NO.	PART NO.	DESCRIPTION
1	STC-1651	WOOFER BRKT F
2	STC-1652	WOOFER BRKT R
101	130-5160	SUB WOOFER 4 OHM 30W

ASSY ACCEL&BRAKE (SPG-2200)

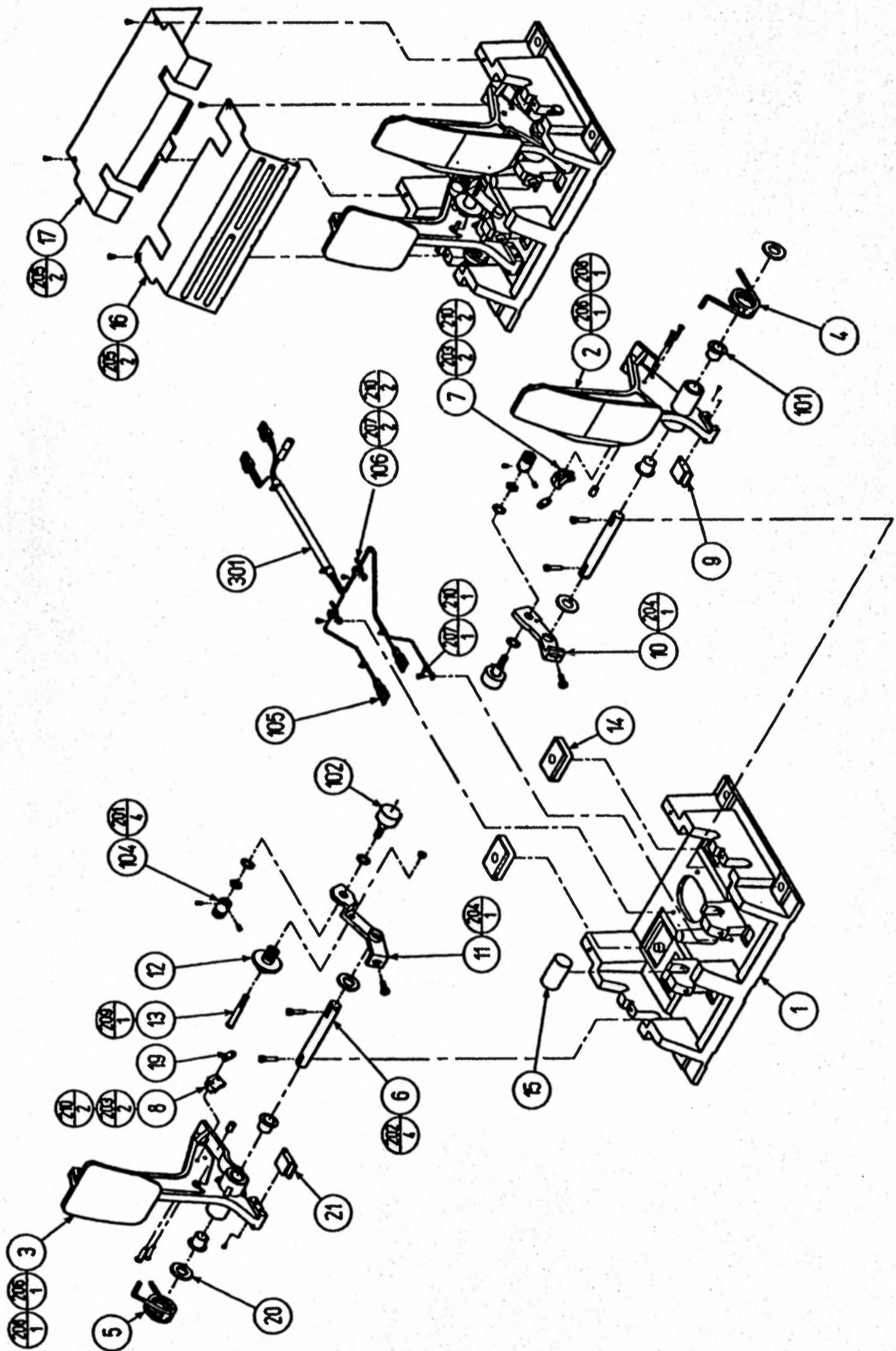

ASSY ACCEL&BRAKE (SPG-2200)

ITEM NO.	PART NO.	DESCRIPTION
1	SPG-2201	BASE
2	SPG-2202	ACCEL PEDAL
3	SPG-2203	BRAKE PEDAL
4	SPG-2204	ACCEL SPRING
5	SPG-2205	BRAKE SPRING
6	SPG-2206	SHAFT
7	SPG-2207	ACCEL GEAR
8	SPG-2208	BRAKE GEAR
9	SPG-2209	NUETRAL STOPPER
10	SPG-2210	VR PLATE ACCEL
11	SPG-2211	VR PLATE BRAKE
12	SPG-2212	AMPL GEAR
13	SPG-2213	GEAR SHAFT
14	SPG-2214	STOPPER
15	SPG-2215	RUBBER CUSHION
16	SPG-2216	COVER
17	SPG-2217	VR COVER
19	SPG-2219	GEAR STAY
20	SPG-2220	WSHR
21	SPG-2221	NUETRAL STOPPER
101	100-5263	BEARING 12
102	220-5484	VOL CONT B-5K OHM
104	601-7944	GEAR 15
105	310-5029-F15	SUMI TUBE F F 15MM
106	280-0419	HARNES LUG
201	028-A00304-P	SET SCR HEX SKT CUP P M3X4
202	020-000520-OZ	HEX SKT H CAP SCR BLK M5X20
203	000-P00420	M SCR PH M4X20
204	000-P00508-W	M SCR PH W/FS M5X8
205	000-T00408-OC	M SCR TH CRM M4X20
206	FAS-450005	SPR PIN BLK OZ 6X10
207	000-P00405	M SCR PH M4X5
208	FAS-000001	M SCR TH CRM M3X6
209	050-H00500	HEX NUT M5
210	060-F00400	FLT WSHR M4

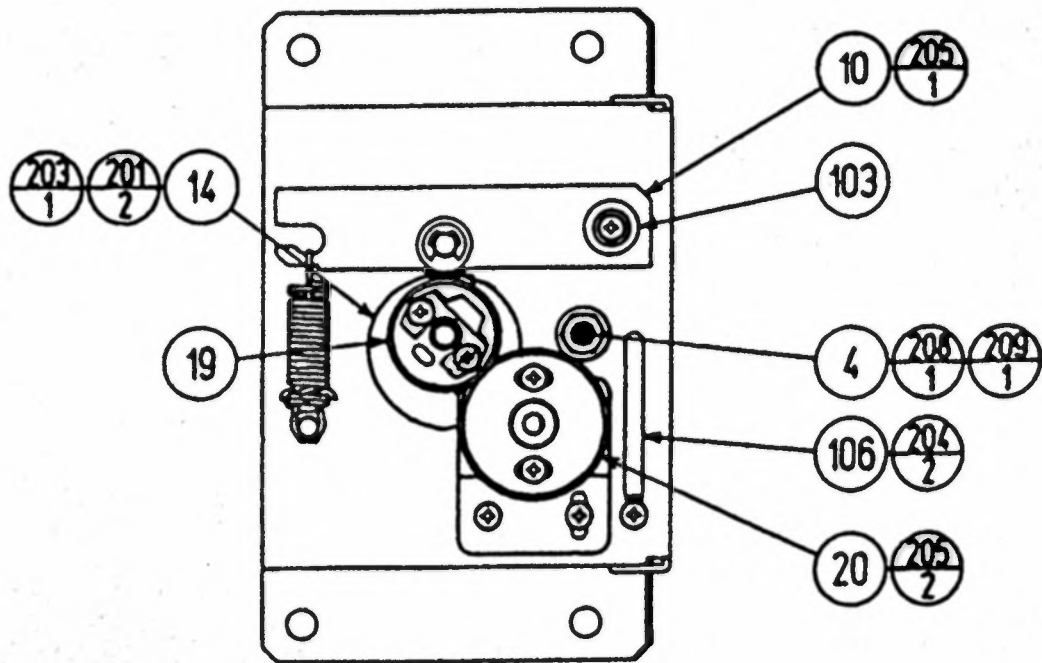
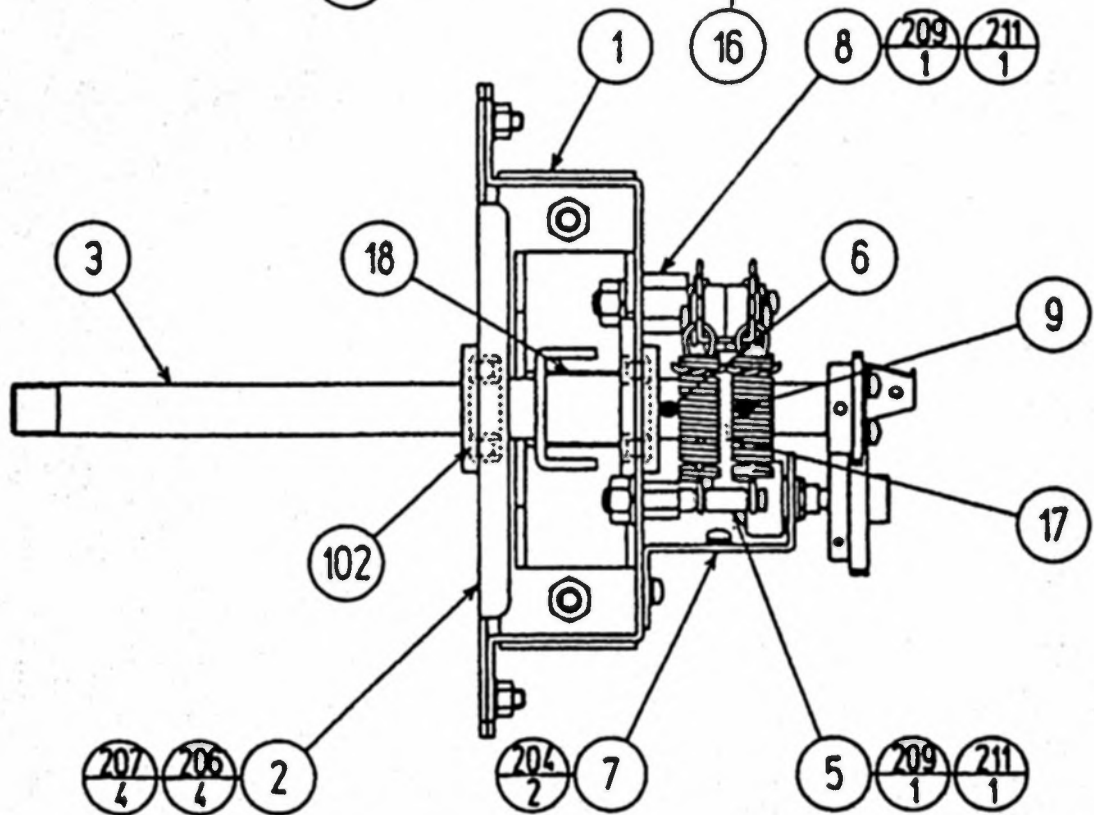
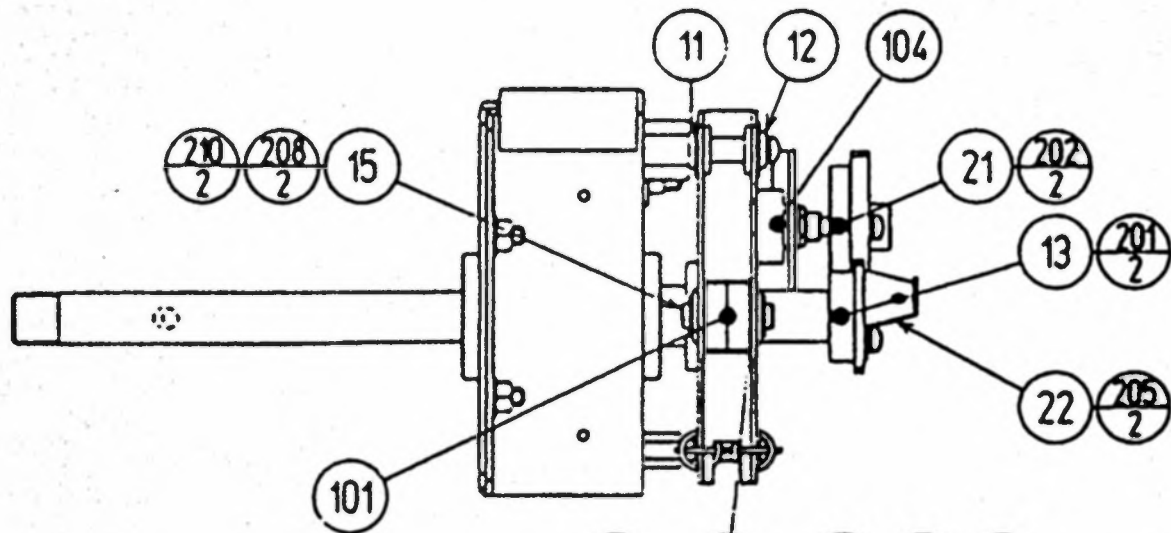

ASSY HANDLE MECHA (CTA-2100)

ITEM NO.	PART NO.	DESCRIPTION
1	CTA-2101	HANDLE BASE
2	CTA-2101	BASE LID
3	CTA-2103	HANDLE SHAFT
4	CTA-2104	STOPPER BOLT
5	CTA-2105	SPRING HOOK
6	CTA-2106	SPACER RING
7	CTA-2107	VR BRKT
8	DYN-1262	SWING ARM SHAFT
9	DYN-1269	EXT SPRING
10	DYN-1273	SWING ARM
11	BVG-1340	FLT WSHR 8.1-12X2
12	BVG-1341	FLT WSHR 4.1-12X2
13	SLC-1130	ADJUST RING
14	SLC-1141X	WHITE CAM
15	SOR-2112	BEARING SHAFT
16	SOR-2113	SPACER
17	SOR-2115	KEY 5X10
18	SPG-2109	STOPPER RUBBER
19	601-6172	GEAR 48
20	601-6959	GEAR 64
21	601-8966	GEAR HOLDER
22	SLC-1108	WIRE HOLDER
101	100-5018	BEARING BALL 8
102	100-5112	BEARING 17
103	100-5041	BEARING NSK F688 ZZ
104	220-5484	VOL CONT B-5K OHM
201	028-A00408-P	SET SCR HEX SKT CUP P M4X8
202	028-A00308-P	SET SCR HEX SKT CUP P M3X8
203	FAS-650011	STP RING BLK OZ S17
204	000-P00408-W	M SCR PH W/FS M4X8
205	000-P00412-W	M SCR PH W/FS M4X12
206	060-F00600	FLT WSHR M6
207	050-U00600	U NUT M6
208	060-F00800	FLT WSHR M8
209	050-U00800	U NUT M8
210	065-E00700	E RING 7MM
211	060-S00800	SPR WSHR M8

ASSY SHIELD CASE NAO (840-0002D-01)

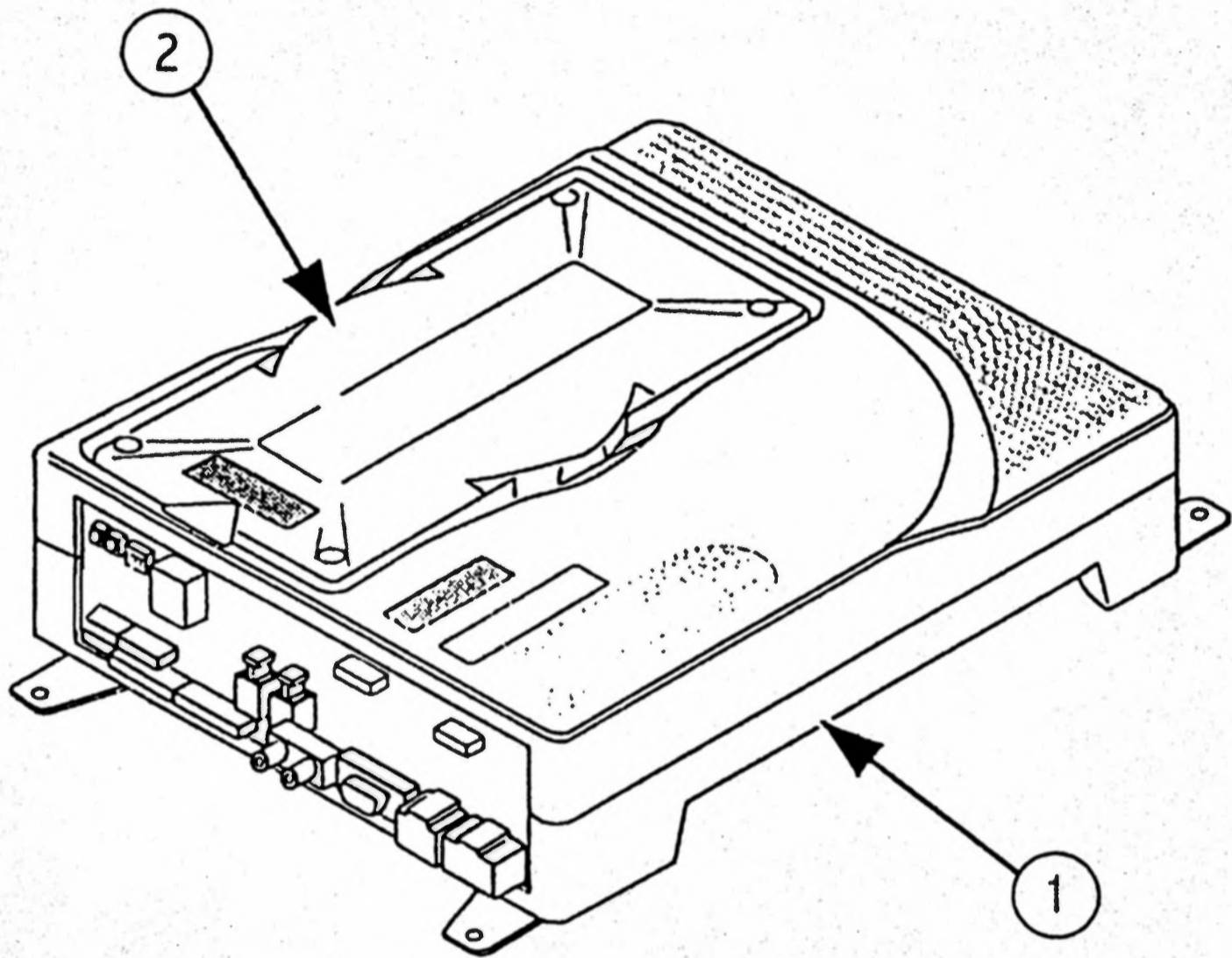

ITEM NO.	PART NO.	DESCRIPTION
1	840-0001A-01	SHIELD CASE CTA NAO USA
2	840-0001C	ROM CASE NAO

ASSY ELEC BASE (CTA1-4500)

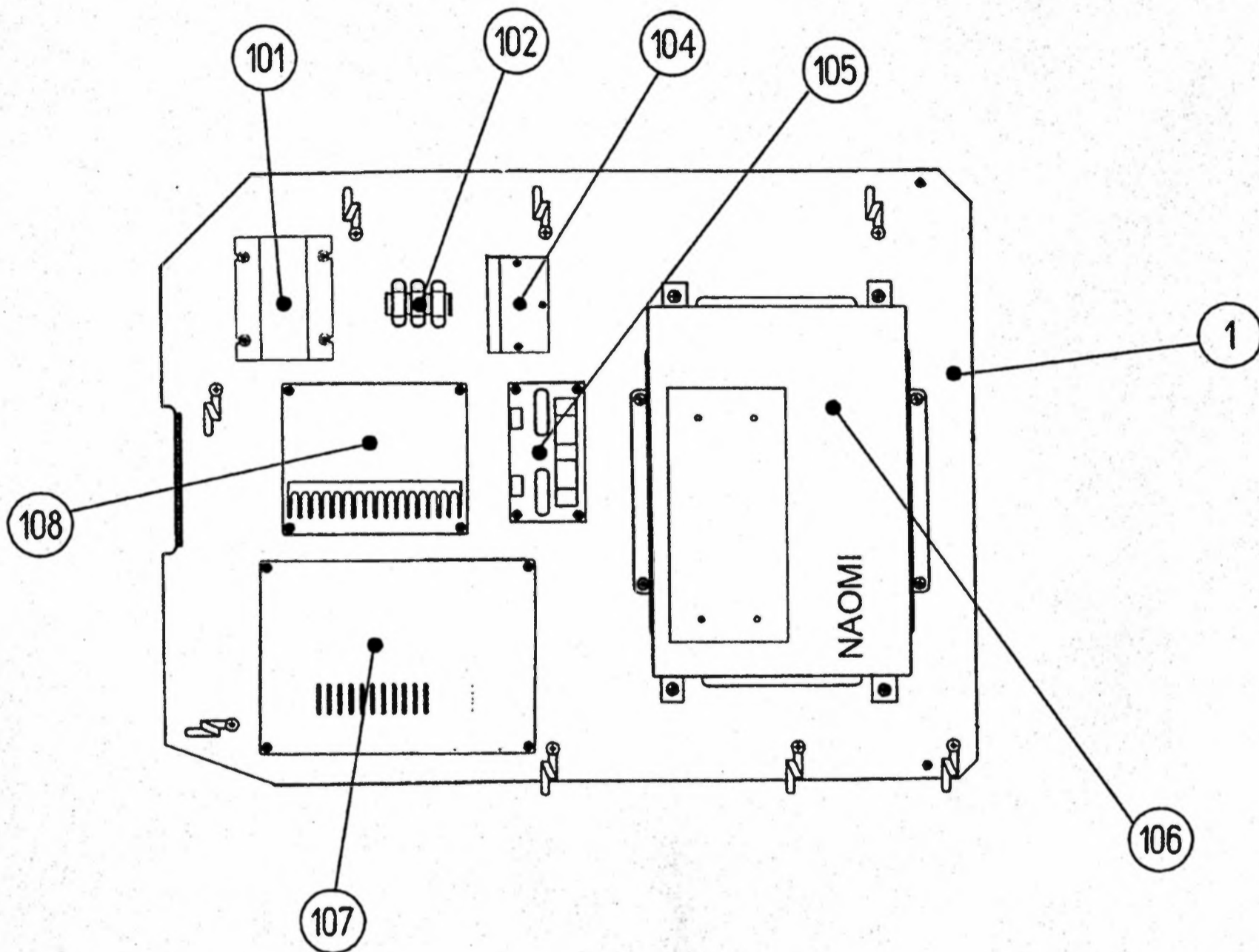

ITEM NO.	PART NO.	DESCRIPTION
1	NOT AVAILABLE	WOODEN BASE ELEC
101	560-5250-01	XFMR 12.8V 8A
102	LOCAL PURCHASE	FUSE BLOCK W/ FUSES
104	838-11651-91	LOW PASS AMP
105	837-13551-92	I/O BD
106	840-0002D-01	NAOMI BD
107	400-5330-03	PWR SPPLY
108	838-11650-29	EQ POWER AMP

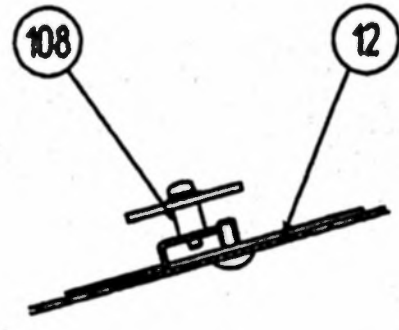
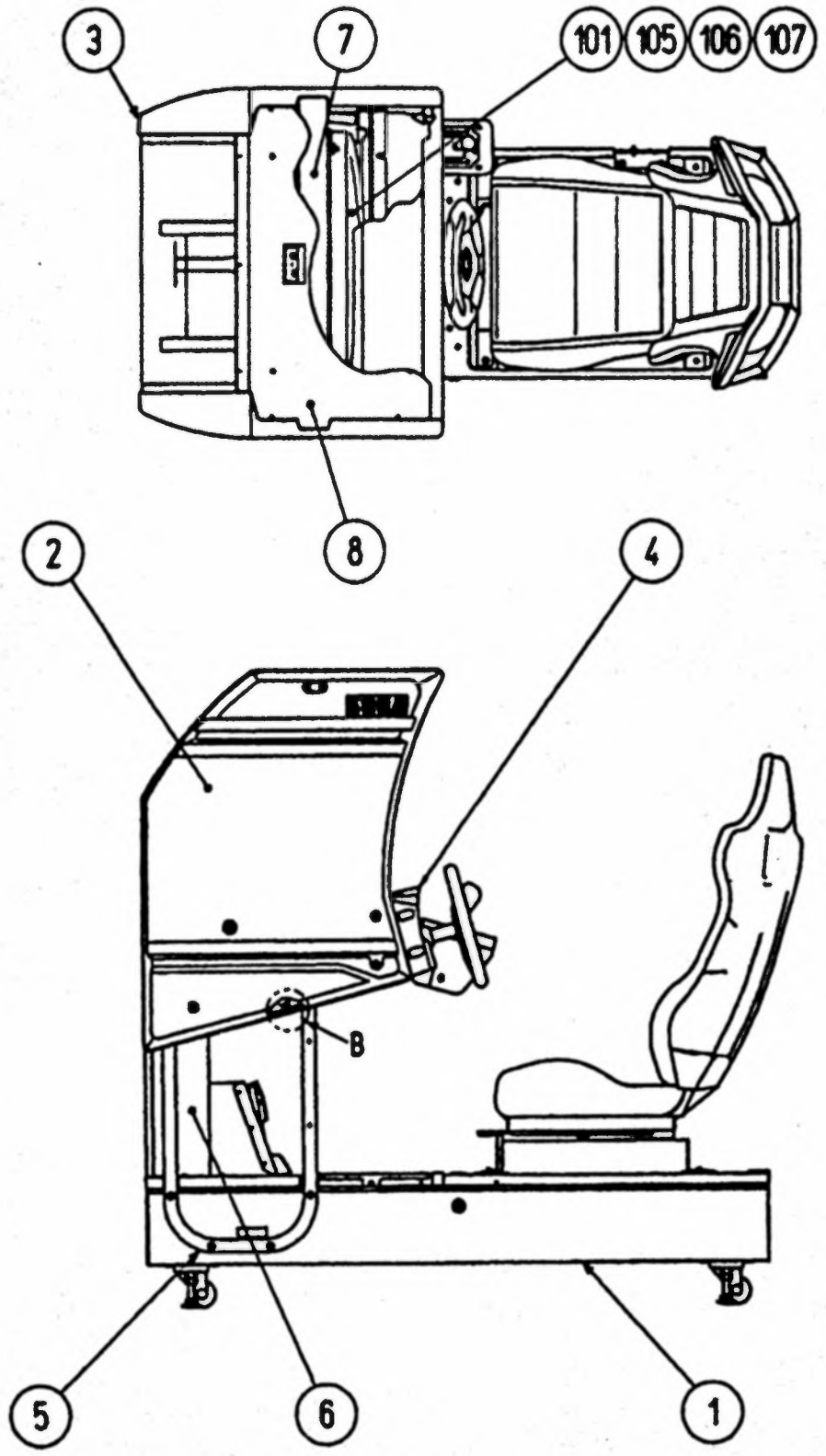

Details of PART B

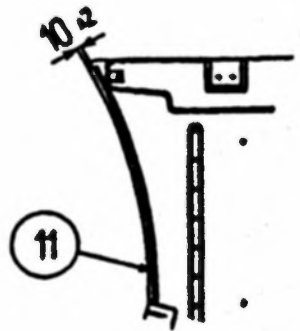
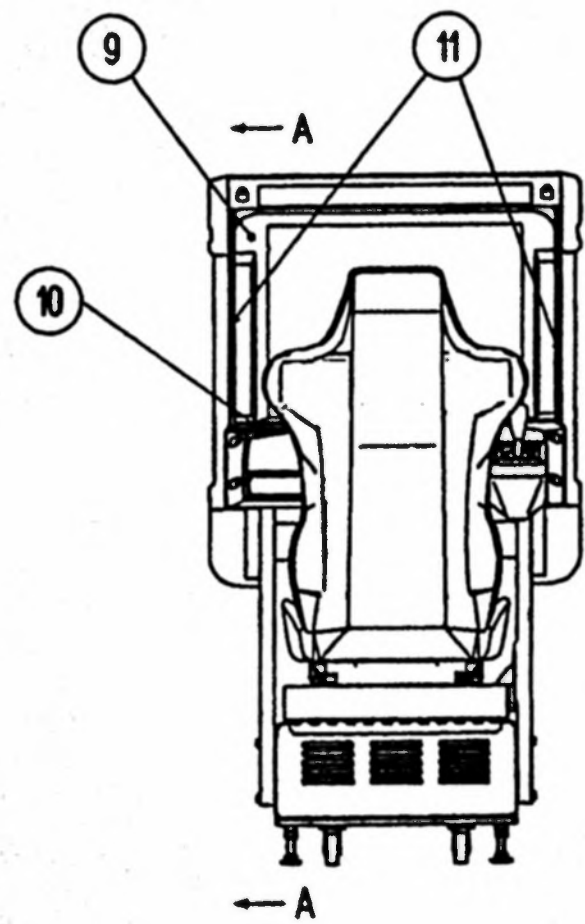

SECTION A-A

ASSY COCKPIT 1P (DRT1-10001)

ITEM NO.	PART NO.	DESCRIPTION
1	DRT5-20001	ASSY MAIN BASE 1P
2	DRT5-1030	ASSY MONITOR COVER L 1P
3	DRT5-1045	ASSY MONITOR COVER R 1P
4	DRT5-1201	ASSY CONTROL PANEL CTA
5	SPG-1004	MONITOR STAND
6	SRT-1002	WIRE COVER BOX
7	INY-1016	MONITOR SUPPORT
8	SPG-1008	ROOF LID
9	TTR-1067X	MONITOR MASK
10	SPG-1005	MASK HOLDER
11	DYN-1025	RUBBER CUSHION
12	INY-1015	CRT ADJUST PANEL
101	200-5787	ASSY CLR DSPL 29 TYPE 31K 100V
105	280-5112	BUSH FOR TV
106	280-5113	COLLAR FOR TV
107	280-5114	SPACER 6.4-25x2
108	280-5185-6	SPACER TUBE L=6
109	601-6231-C100	EDGING NEW TYPE

ASSY CONTROL PANEL (DRT1-1200-02)

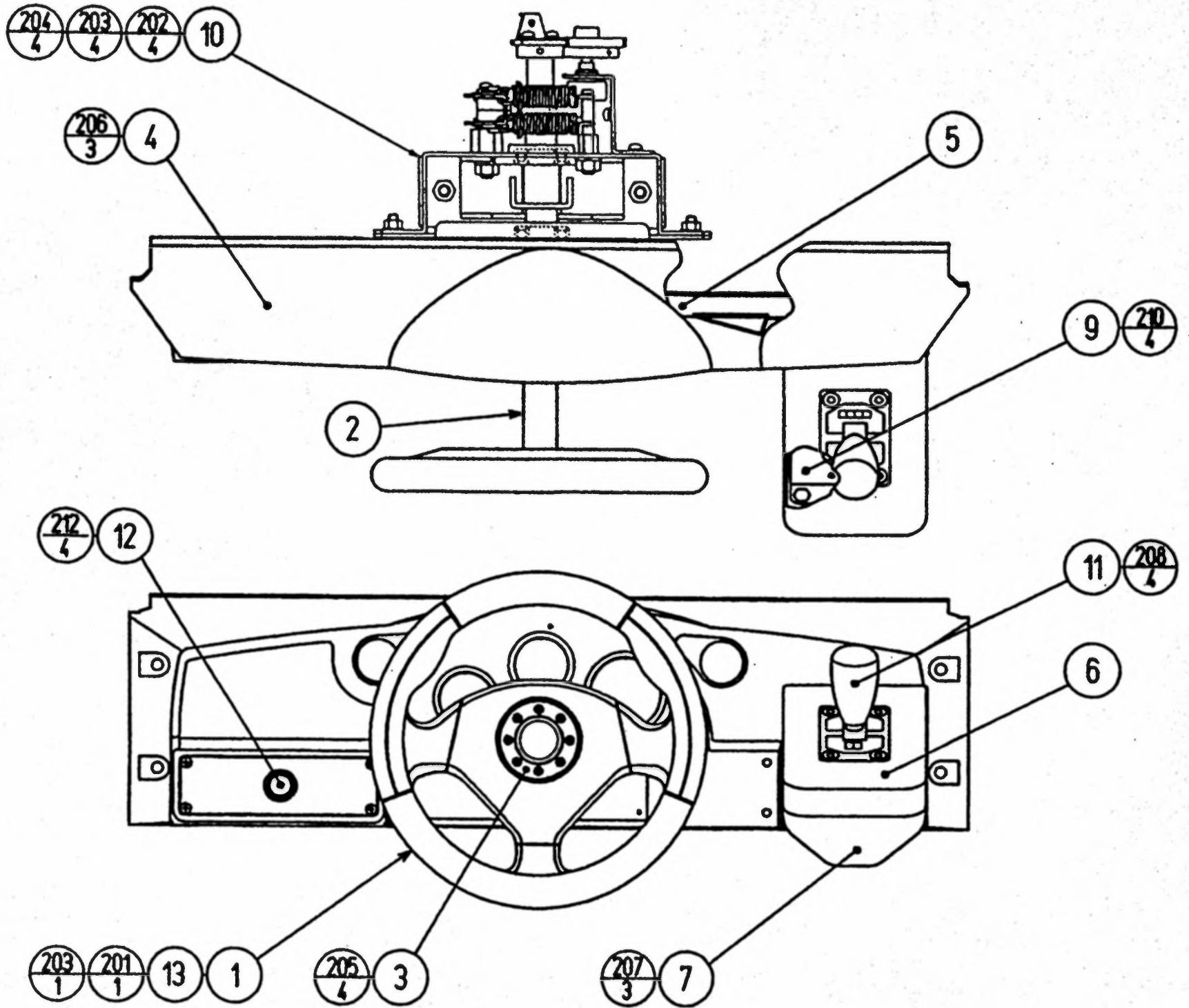

ASSY CONTROL PANEL (DRT1-1200-02)

ITEM NO.	PART NO.	DESCRIPTION
1	DYN-1201	STEERING WHEEL
2	DYN-1209X	HANDLE COLLAR
3	SPG-2002	STEERING EMBLEM
4	DRT1 -1201-01	CONTROL PANEL COVER ENG
5	SPG-1205	CONTROL PANEL BRKT
6	INY-1204	SHIFT COVER INY
7	DYN-1223X	SHIFT COVER B
9	SPG-1204	SPL BLT M8
10	CTA-2100	ASSY HANDLE MECHA
11	610-0384	ASSY SHIFTER
12	DRT5-1290	ASSY VIRTUAL BUTTON CTA
13	SPG-2039	SPACER RING
201	020-000820-0Z	HEX SKT H CAP SCR BLK OZ M8X20
202	060-F00800	FLT WSHR M8
203	060-S00800	SPR WSHR M8
204	050-H00800	HEX NUT M8
205	FAS-200013	HEX SKT H CAP SCR CRM M4X16
206	000-T00416-0B	M SCR TH BLK M4X16
207	000-P00412-W	M SCR PH W/FS M4X12
208	008-T00516-0B	TMP PRF SCR TH BLK M5X16
210	030-000820-S	HEX BLT W/S M3X12
212	000-T00412-0C	M SCR TH CRM M4X12

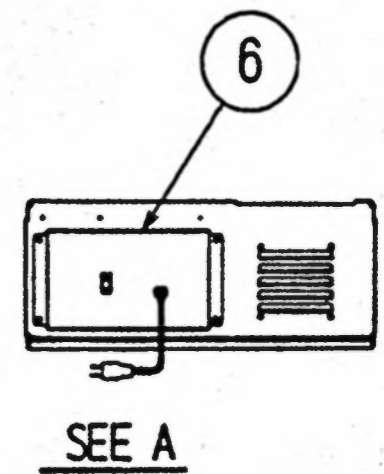
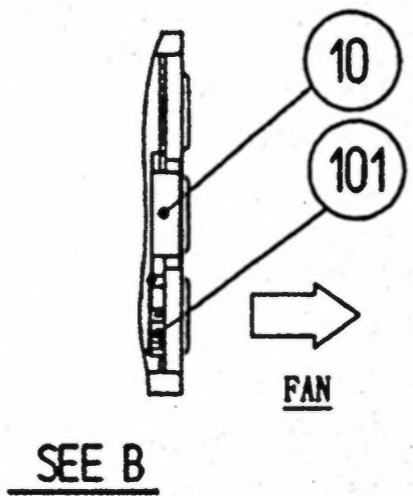
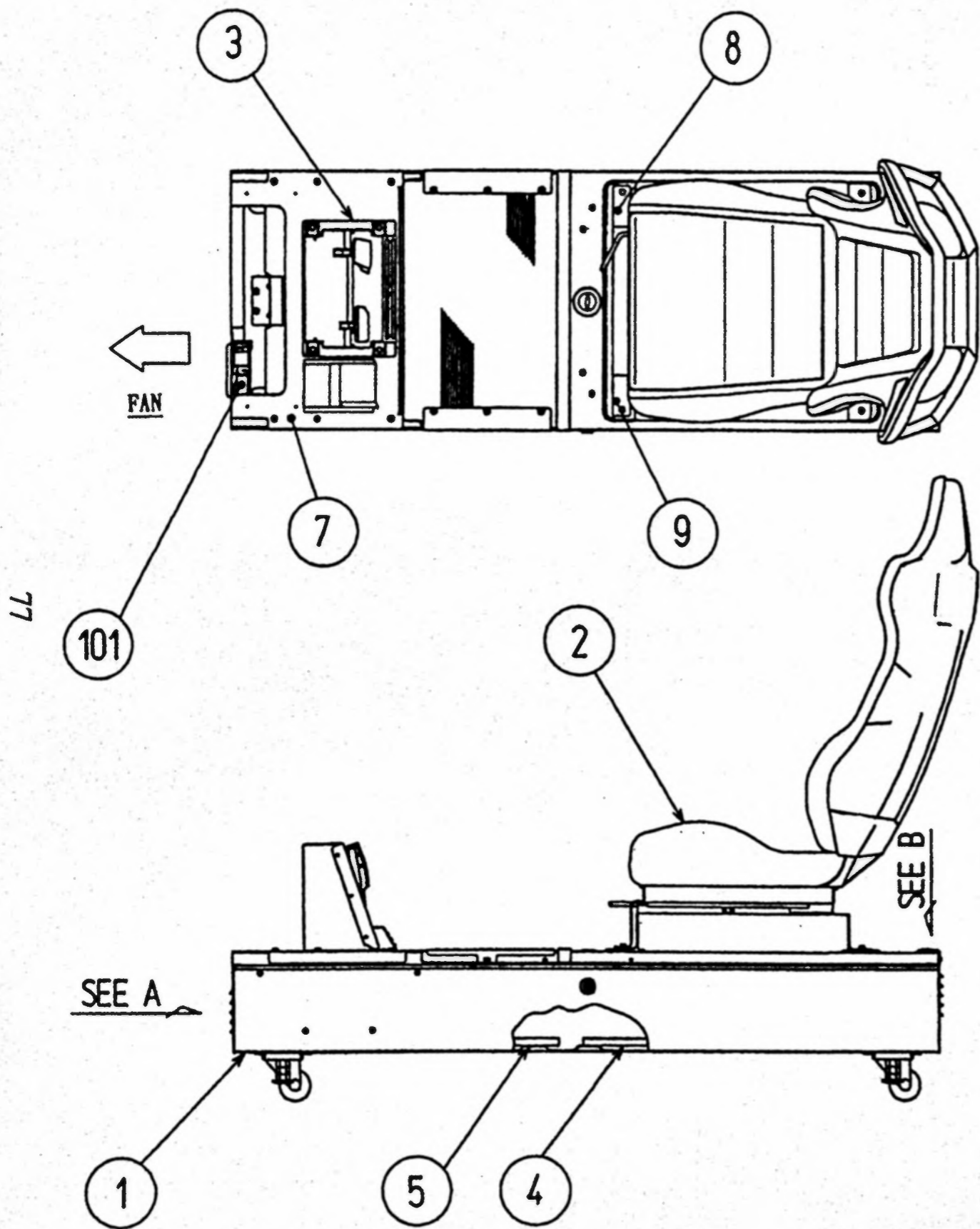

TORQUE: M6 84kgf·cm  
M8 195kgf·cm

ASSY MAIN BASE 1P (DRT5-20001)

ITEM NO.	PART NO.	DESCRIPTION
1	DRT-1500	ASSY BASE BOX
2	DRT-1600	ASSY SEAT TWIN 1P
3	SPG-2200	ASSY ACCEL&BRAKE
5	CTA1-4500	ASSY ELEC BASE
6	SRT1-0400	AC UNIT
7	SPG-1502	PEDAL BASE
8	RAL-2007	RUBBER HOLDER R TWIN
9	RAL-2008	RUBBER HOLDER L TWIN
10	SPG-1503	FAN BRKT
101	260-0011	AXIAL FLOW FAN AC100V 50-60 HZ



# VISIT OUR WEBSITE!

Netscape: SEU SERVICE HOMEPAGE

Go To: <http://www.seuservice.com/SEGASERVICE/mainpage.html> What's Related

## SEGA SERVICE

[What's new] [Manuals] [Bulletins] [Part Numbers] [Game Monitors]  
[Board Systems] [Mailing List] [SEGA Distributors] [Service Staff] [Darl's Office] [Samples]



- WHAT'S NEW
- MANUALS
- BULLETINS
- PART NUMBERS
- GAME MONITORS
- BOARD SYSTEMS
- MAILING LIST
- SEGA DISTRIBUTORS
- SERVICE STAFF
- DARL'S OFFICE
- HOME

[Y2K COMPLIANCE]

Sega Enterprises Inc., USA  
Service Department  
Phone (650)-632-7580  
Fax (650)-632-7594

Best Viewed with 

### Coin-Op Links:

[Star Tech Journal](#)

[Amusement Industry Mega Site](#)

*If you have any questions about this Home Page please E-Mail to:*

[darl.davidson@seu.sega.com](mailto:darl.davidson@seu.sega.com)  
OR  
[han.rockhill@seu.sega.com](mailto:han.rockhill@seu.sega.com)

A total of **13910** people have accessed this page.

THIS WEB SITE POWERED BY   

**SEGA**

**SEGA ENTERPRISES, INC. (USA)**

45133 Industrial Drive  
Fremont, CA 94538  
(415) 701-6580 phone  
(415) 701-6594 fax