

# DEATH RACE

EXIDY  
SERVICE  
MANUAL

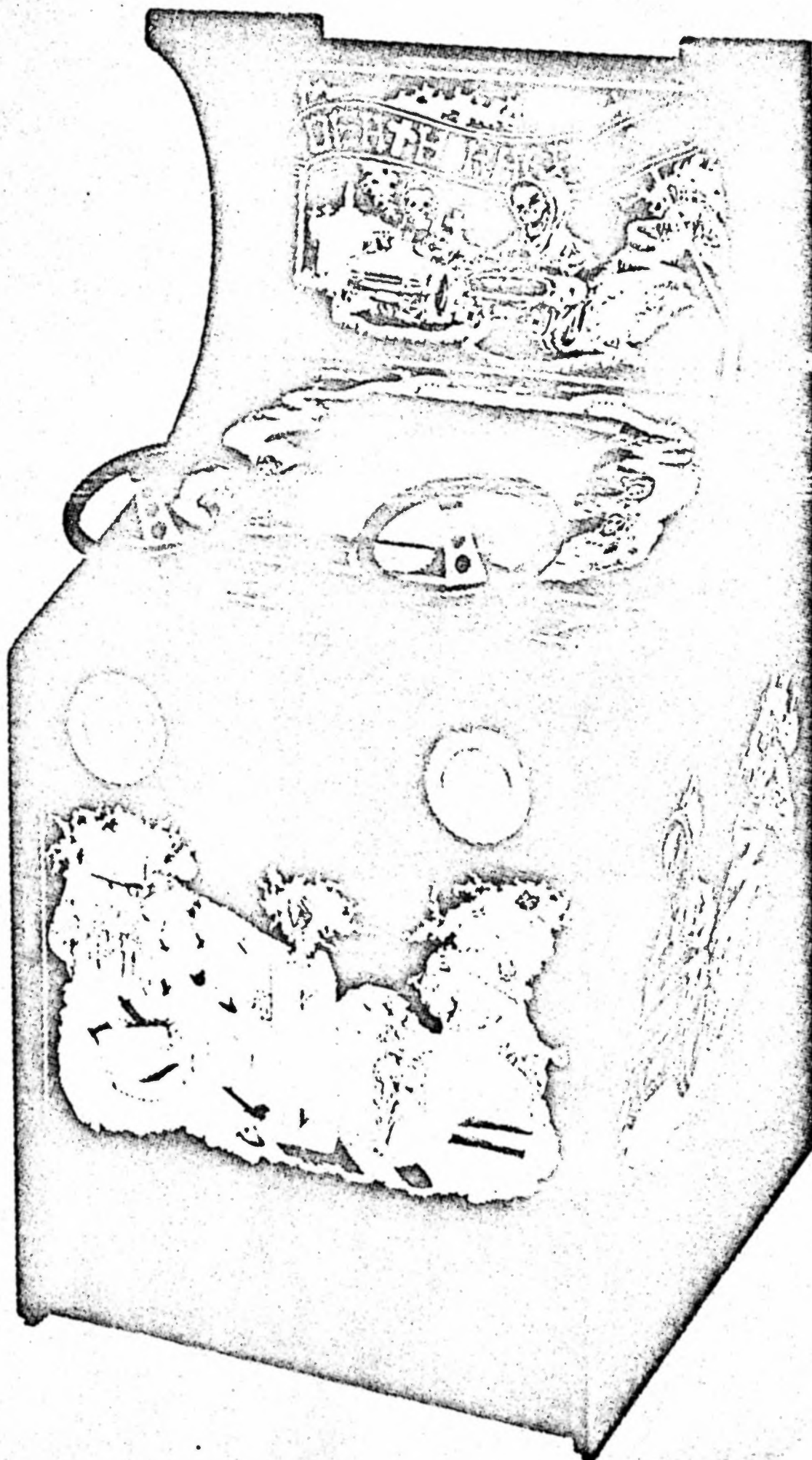

## TABLE OF CONTENTS

	PAGE NO.
I. GENERAL INFORMATION	1
II. OBJECT OF THE GAME	1
III. NORMAL OPERATION	1
IV. SYSTEM FUNCTIONAL DESCRIPTION	2
Power Supply	
Logic Printed Circuit Board (PCB)	
Coin Mechanism	
Start Switch	
Steering Units	
Pedal Units	
Speakers	
T.V. Monitor	
Shift Lever	
V. TROUBLESHOOTING TIPS	2
Picture not present	
Entire picture scrambled	
Picture present but partially bad or characters act incorrectly	3
Bad Steering	
No shift	
No acceleration or bad acceleration	
No game start/sound present	
No game start/sound not present	
Game starts/no sound	
VI. ADJUSTMENTS	
Power Supply Adjustment	4
Volume Adjustment	
Tone Adjustment	
Game Time Adjustments	
VII. FIGURES	
Figure 1 — Main Cabinet (Exploded View)	6-7
Figure 2 — Steering Box and Display (Exploded View)	8-9
Figure 3 — Foot Pedal Assembly (Rear View)	11
Figure 4 — Power Supply	13
Figure 5 — Optical (Steering) Board	15
Figure 6 — Logic Printed Circuit Board (PCB)	16
Figure 7 — System Block Diagram	19
Figure 8 — Wiring Diagram	20-21
Figure 9 — Acceleration (Foot Pedal) Wiring	23
Figure 10 — Optical Steering Board Schematic	
Figure 11 — Steering Mech. Detail (Exploded View)	

# DEATH RACE

## I. GENERAL INFORMATION

Death Race pits the player against an intelligent acting, evasive, running Gremlin. Unlike most "player versus machine" games, the "machine" in this case does not simply repeat an action or sequence, but actually "sees", "thinks", and "acts" as intelligently (and even more rapidly) than would another player. The result of this is that each game is a new and different experience.

## II. OBJECT OF THE GAME

The object of the game is simple. Hit a Gremlin and you win a point.

There are two Gremlins running around the playing field in a random fashion. They are intelligent robots in every sense and will avoid all objects so long as they can see a way to escape.

You drive one of two cars which are completely under your control. You can steer them anywhere in any direction within the playing field; move forward in low or high gear; and move in reverse when necessary. You can drive as fast, but no faster than the Gremlins can run.

When you hit a Gremlin a tombstone (cross) will appear and remain in that same spot until the game is over and a new game begun. Wherever you hit a Gremlin on the playing field, the cross will remain. Thus, each game creates its own totally random and different maze of crosses that each player must steer through while chasing the Gremlins. The more hits, the more crosses; the more crosses, the harder the steering becomes. Thus, it becomes increasingly difficult to maneuver as your skill increases.

## III. NORMAL OPERATION

The screen is divided horizontally into three (3) areas: the larger being in the middle between the dotted lines. This represents the legitimate playing field. It is only in this area that hits can occur; and any car that attempts to leave this area will crash when it contacts the top, bottom, or (dotted) side lines. There is no point given or cross created for this type of crash.

Although the cars will crash when trying to cross the dotted line toward the solid sideline, the Gremlins can and do pass through without crashing.

The areas on the sides between the solid and dotted lines are a designated "safe" area for the Gremlins. They will enter this area at will.

When you crash your car into anything, whether it be a Gremlin, cross, or a boundary (line), your car will pause briefly before moving again, unless you immediately shift into reverse to back away from the scene of the crash. Even if you do not back away, your car will begin to move again. It is thus possible to crash into and pass through, after a pause, any boundary. Although by this method you can leave the playing field and pass into the safe zone or other "out of bounds" areas, you cannot intercept and hit a Gremlin nor receive a point outside the playing field.

Once outside the playing field, you may drive your car off the visible screen and it will reappear on the opposite side of the screen. The Gremlins can do this also but should only do so if the safe zone area is blocked and there is no place for them to enter the playing field. In this case, they will normally run off the screen to the side and reappear on the opposite side. A Gremlin should never pass through the top or bottom boundaries.

Should one player crash into the other player, both cars will pause briefly before proceeding. Because of this, it is sometimes advantageous to crash into your opponent's car in order to slow down and prevent your opponent from hitting a Gremlin and scoring. There is no score from crashing into your opponent's driven car.

When one coin is inserted the sound for player one is enabled. When a second coin is inserted, the sound for player two is enabled. When the start button is depressed the game begins, the players can drive their cars and the game counter counts down from 99 toward 00. The duration of the game is adjustable in three (3) increments from one (1) minute twenty (20) seconds, to two (2) minutes fifteen (15) seconds. See "ADJUSTMENTS" for information regarding game time.

Each car has two forward speeds. When the pedal is not depressed, the car will not move, but will turn on its axis as the steering wheel is turned. Slight depressing moves the car forward in low gear, and full depression moves the car forward in high gear. If the shift lever is in reverse, the car will move backwards at a low gear speed. There is no high gear in reverse.

#### IV. SYSTEM FUNCTIONAL DESCRIPTION (Refer to System Block Diagram. Fig. 7)

115 VAC power is applied through interlock switch S1 (back door panel) to the power supply, the T.V. monitor, and the light fixtures.

The Power Supply converts this to +5VDC and 22 VAC. The +5VDC is used to power the LOGIC PCB (printed circuit board), Coin Counter, both steering units (optical boards), and both foot pedal units (2 microswitches each), the 22 VAC is used to power the audio (sound circuitry located on the LOGIC PCB.

The Logic PCB generates all video (T.V. picture), audio (sound), and is the nerve center for all control functions.

The Coin Mechanism signals the Logic PCB that a one (1) or two (2) player game can now begin, pending the pressing of the start switch. It also simultaneously signals the coin counter to advance one (1) count for each coin.

The Start Switch, when depressed, signals the logic PCB that a game can now begin.

The Steering Units for player 1 and player 2 are identical, and each consists of a steering wheel, a shift lever, and an optical control board. The optical control board converts the rotation of the steering wheel and the two (2) positions of the shift lever (forward & reverse) into commands which are routed to the Logic PCB, which then interprets and executes these commands, causing the driven cars on screen to react accordingly.

The Pedal Units for player 1 and player 2 are identical and each consists of a spring loaded foot pedal and two (2) microswitches. The pedal, when in the "off" position (not depressed) trips the top microswitch and does not trip the bottom switch. Depressing the pedal down slightly allows both the top and bottom microswitch to be in an "untripped" state, which tells the Logic PCB that the corresponding player is now in low gear. Further depression of the pedal trips the bottom microswitch, telling the Logic PCB that the corresponding player is now in high gear. The image on screen will then react accordingly.

The Speakers, which are located in the steering module, receive their signal directly from the Logic PCB; and are not activated until the coin mechanism has been tripped by a coin. They will remain active only while a game is in progress. When the game ends, so does the sound.

The Shift Lever is part of the steering units, and its signal is developed by the same optical control board as is the steering (see steering units).

#### V. TROUBLESHOOTING TIPS

##### NOTE

The single most important factor in the proper operation of your Death Race game is the power supply voltage adjustment. Before any troubleshooting can be done the power supply voltage must be checked, and adjusted if necessary. See "POWER SUPPLY ADJUSTMENT."

##### PICTURE NOT PRESENT

Check:

1. 115 VAC system power
2. +5VDC power supply
3. All harnesses connected
4. T.V. brightness control

##### ENTIRE PICTURE SCRAMBLED

Check:

1. T.V. horizontal hold control
2. T.V. vertical hold control
3. +5VDC power supply adjusted

**FIGURES**

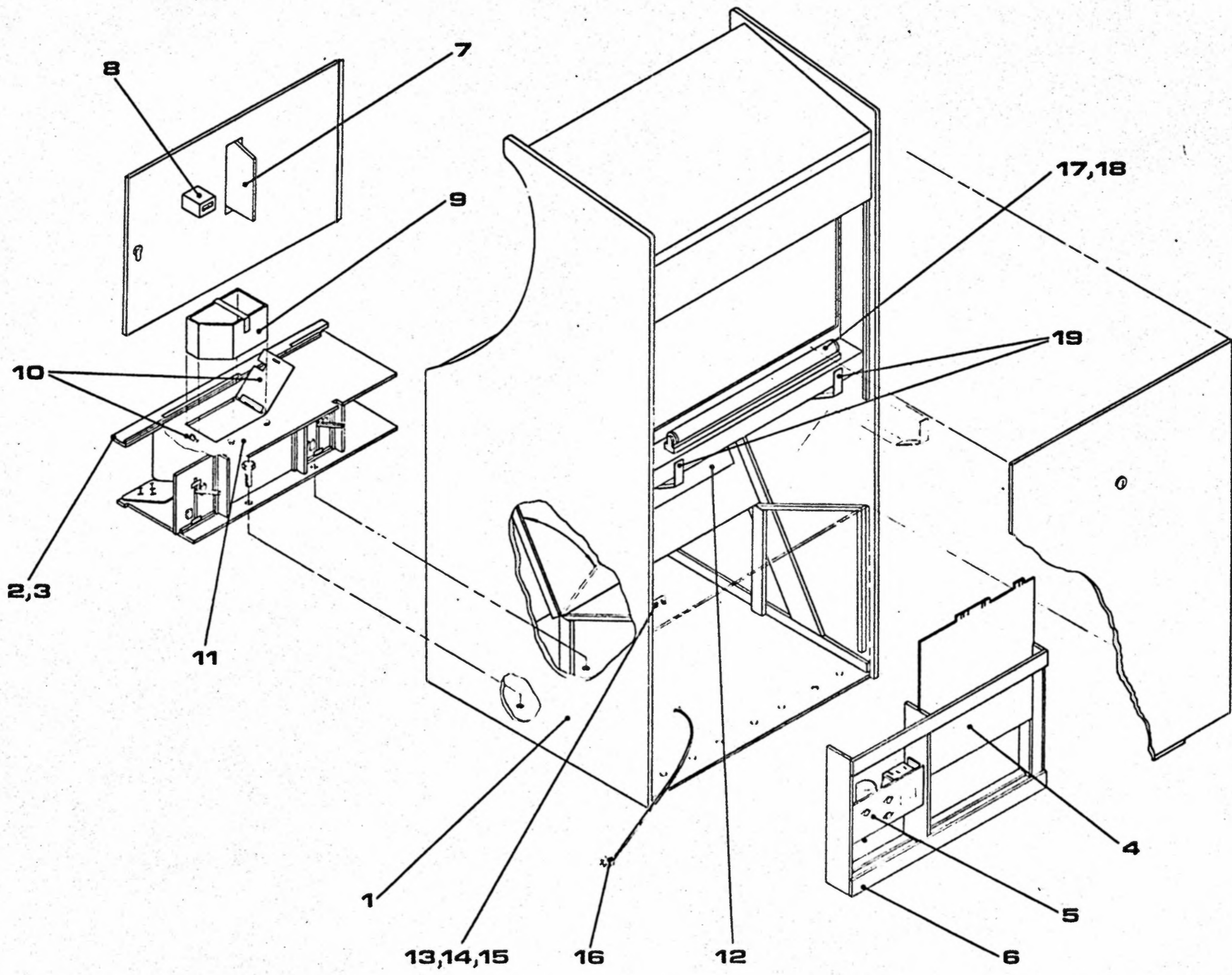

**FIG 1**  
**MAIN CABINET**

7

Figure No. 1		EXIDY
ITEM	PART NO.	DESCRIPTION
1.	DR-UP-CAB	Cabinet
2.	DR-FP-BOX-COMPLETE	Foot pedal box comp
3.	DR-FP-BOX-EMPTY	Foot pedal box empty
4.	DR-PCB-2	Game printed circuit board
5.	EAPS-5-10	Power supply
6.	DR-PCB-PS-B	Power supply & P.C.B. box
7.	2608-300	Coin mech
8.	E607	Coin counter
9.	DR-CB	Coin bucket
10.	DR-CB-LH	Coin box lid & hasp
11.	DR-FP-C	Foot pedal box cover
12.	XM701-10	Monitor
13.	E64-30A	Interlock switch
14.		Fuse holder
15.		Fuse
16.	17412	AC cord
17.	F20T12CW	Fluorescent bulb
18.	S120TS	Fluorescent fixture
19.	DR-MON-BRK7	Monitor brkt.

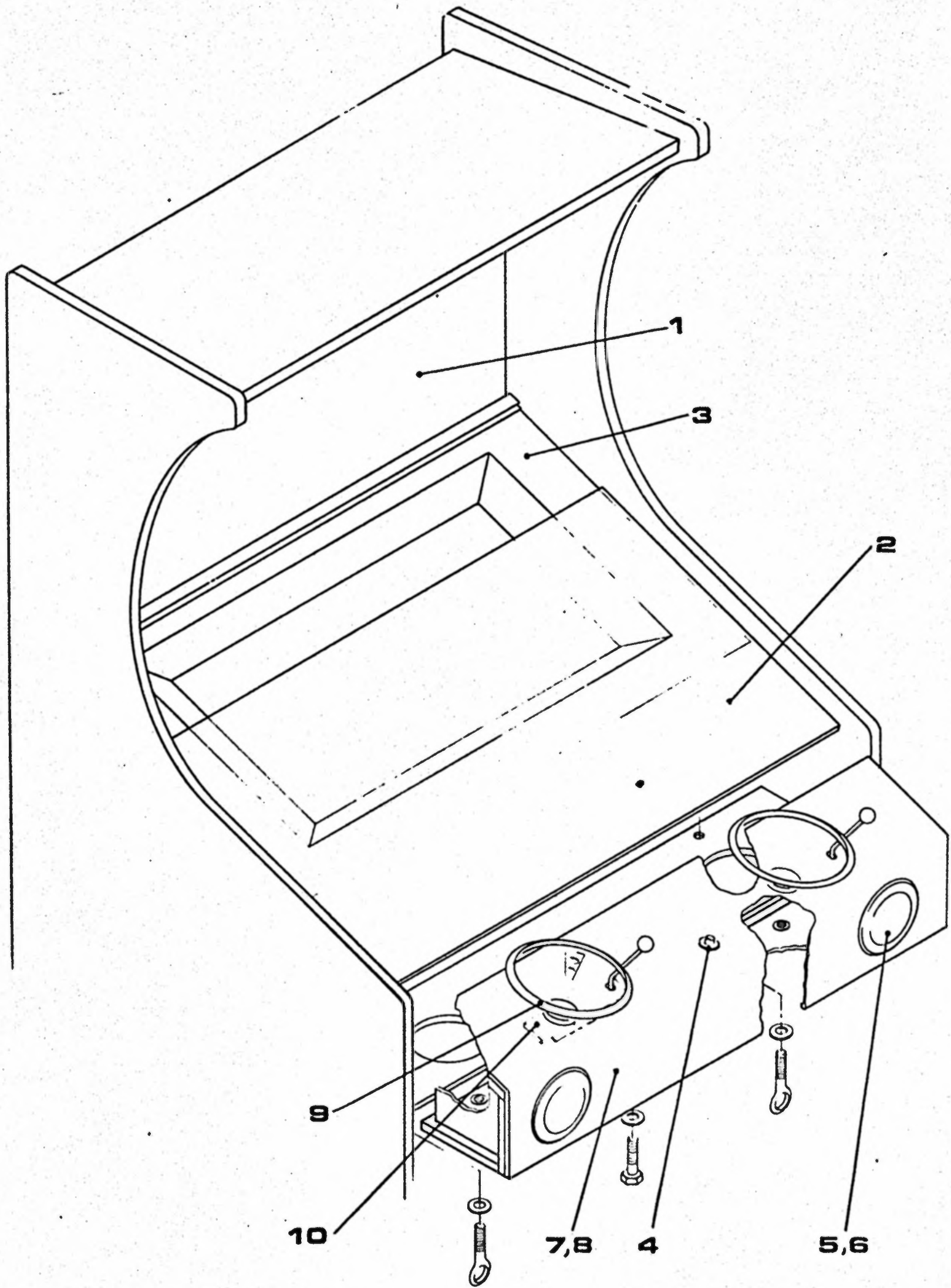

**FIG 2**  
**STEERING BOX AND DISPLAY**

Figure No. 2		EXIDY
ITEM	PART NO.	DESCRIPTION
1.	DR-PLEX-17"	Plex panel destruction derby
2.	DR-PLEX-19¾"	Plex panel frame
3.	23" BEZEL	Bezel
4.	T936-DI-BLK.	Start switch
5.	4" SPKR.-GRL.	Speaker grill
6.	4" SPKR.	Speaker
7.	DR-ST-BOX-COMP.	Steering box complete
8.	DR-ST-BOX-EMPTY	Steering box (less P.C.B.'s & harness)
9.	82-2111	Steering wheel
10.	DR-ST-ASSY	Steering Assy.



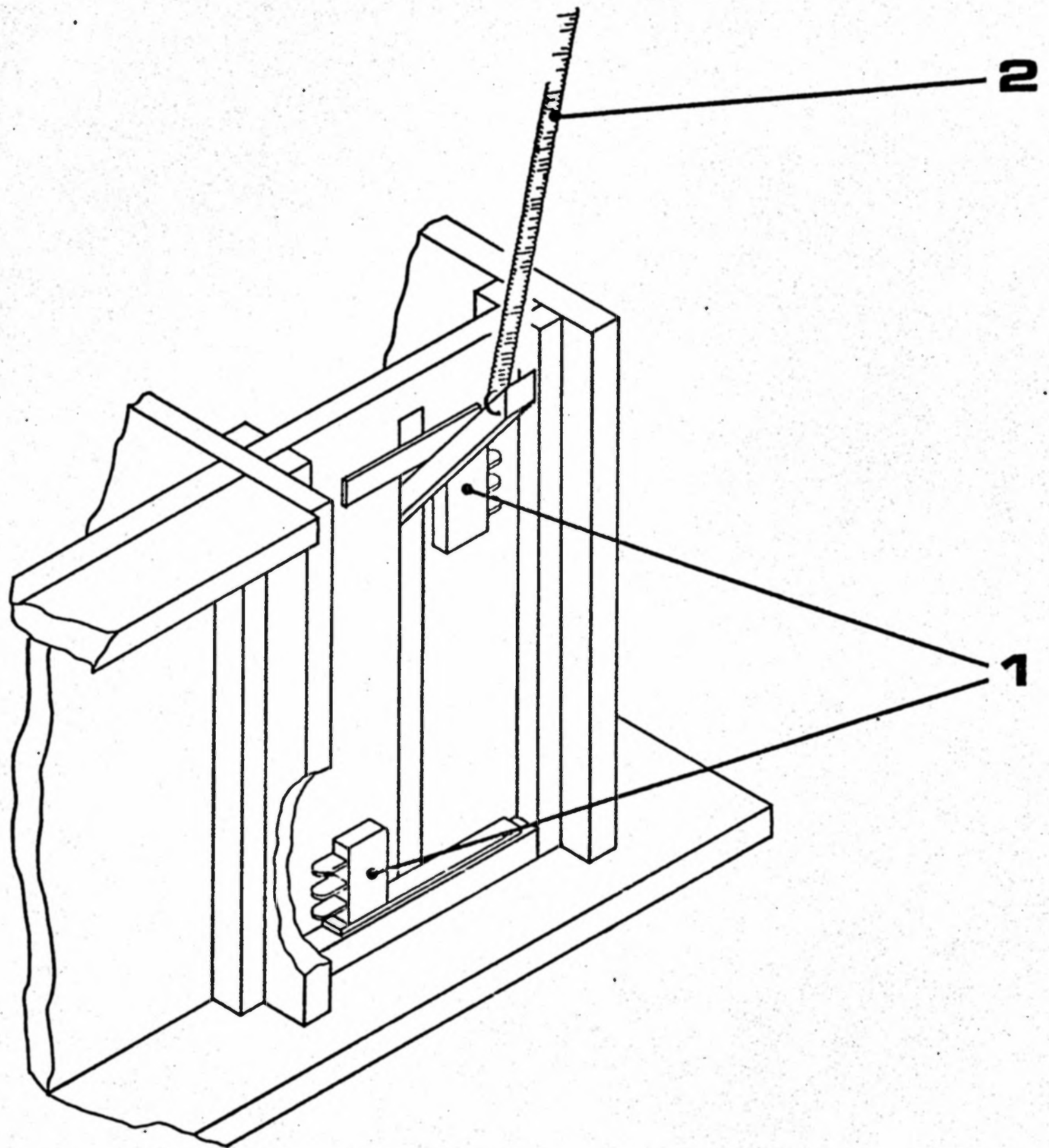

Figure No. 3		EXIDY
ITEM	PART NO.	DESCRIPTION
1.	E51-50R	Foot pedal micro switch
2.	DR-FP-SPRING	Foot pedal spring



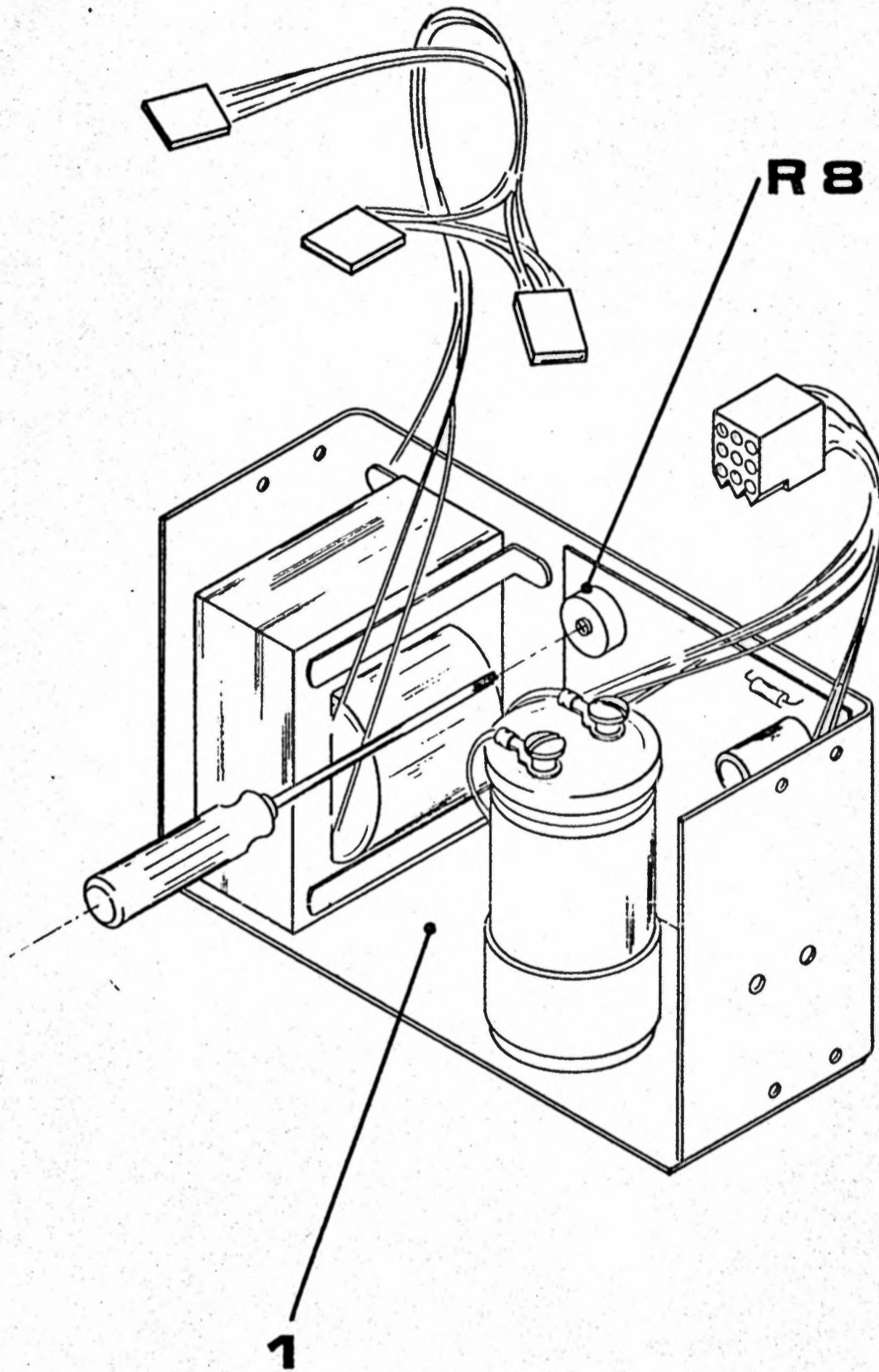

Figure No. 4		EXIDY
ITEM	PART NO.	DESCRIPTION
1.	EAPS-5-10	Power supply (including harness)



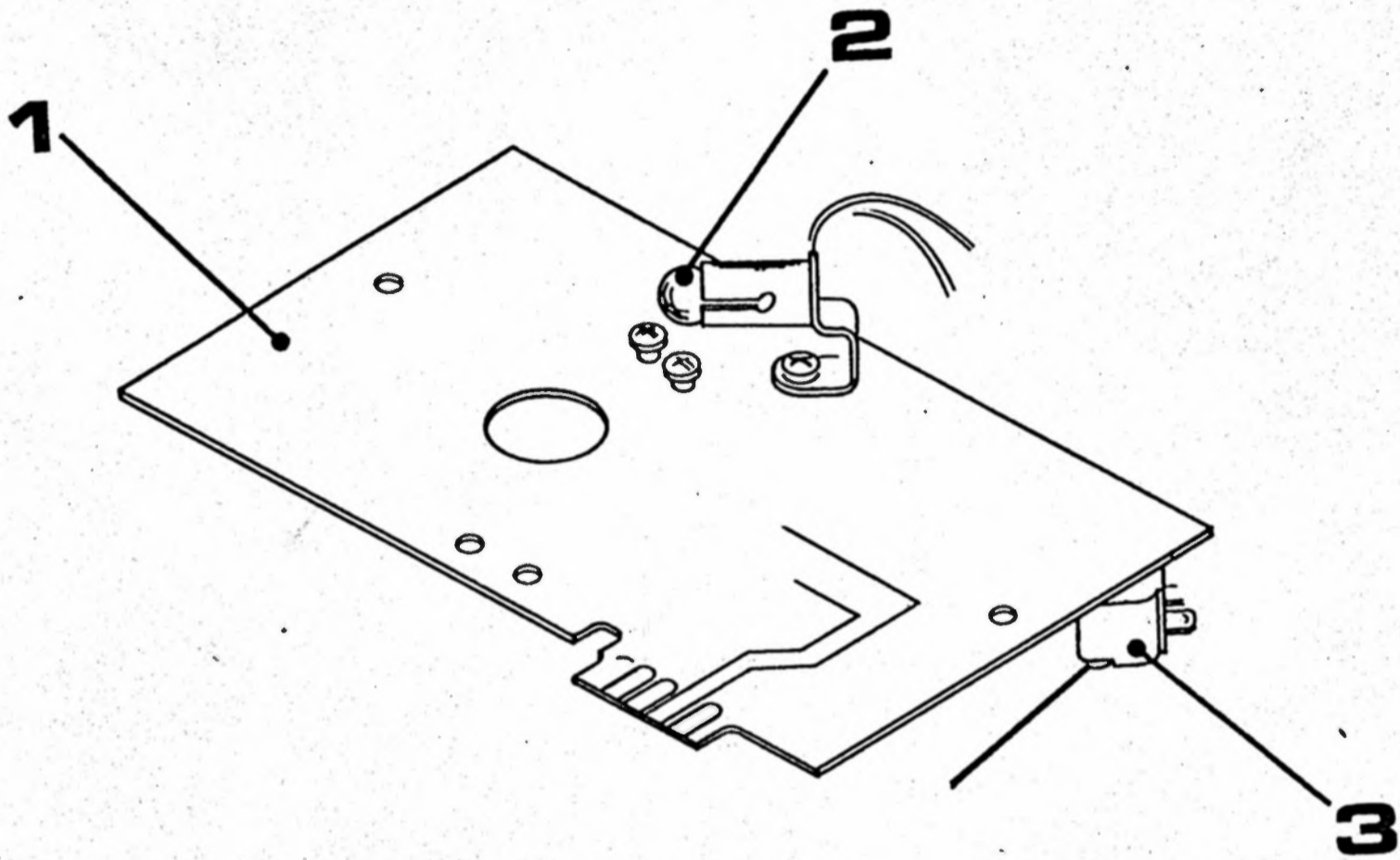
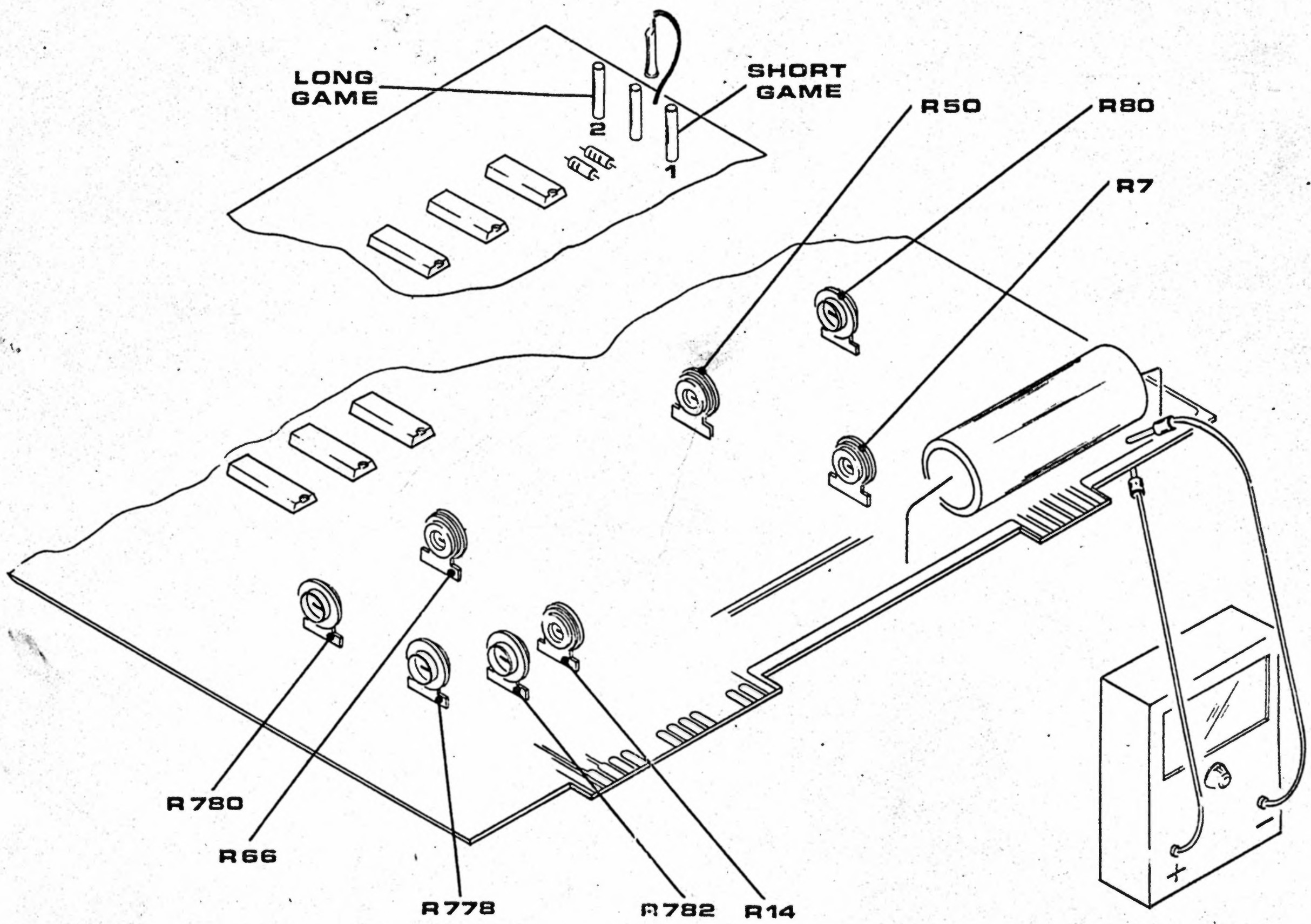

Figure No. 5		EXIDY
ITEM	PART NO.	DESCRIPTION
1.	DR-OCB-ST	Steering P.C.B.
2.	1847 BULB	Twist lock bulb
3.	E51-50R	Micro Switch

**NOTE:**

The Filament of the light bulb on optical control boards (steering boards) must be properly aligned. The bulb (over transistors marked "A", "B") must be directly between and over (in line with) both transistors. Failure to align bulb properly will result in faulty or intermittent steering. Alignment should be initially correct from factory.



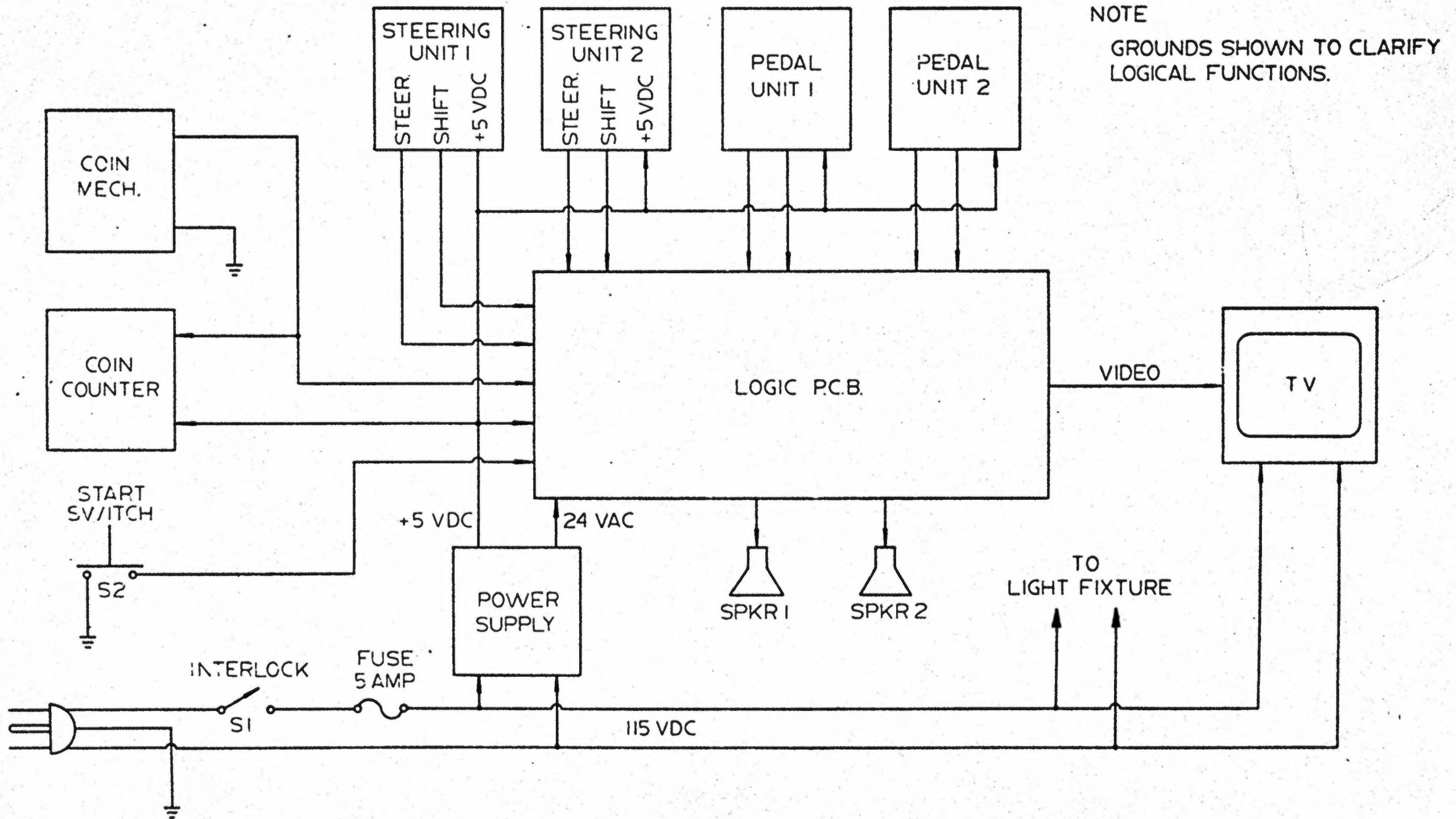

**FIG 6**  
DR1-A



**FIG 7**

**DR SYSTEM BLOCK DIAGRAM**



**FIG. 8**  
DR. WIRING DIAGRAM

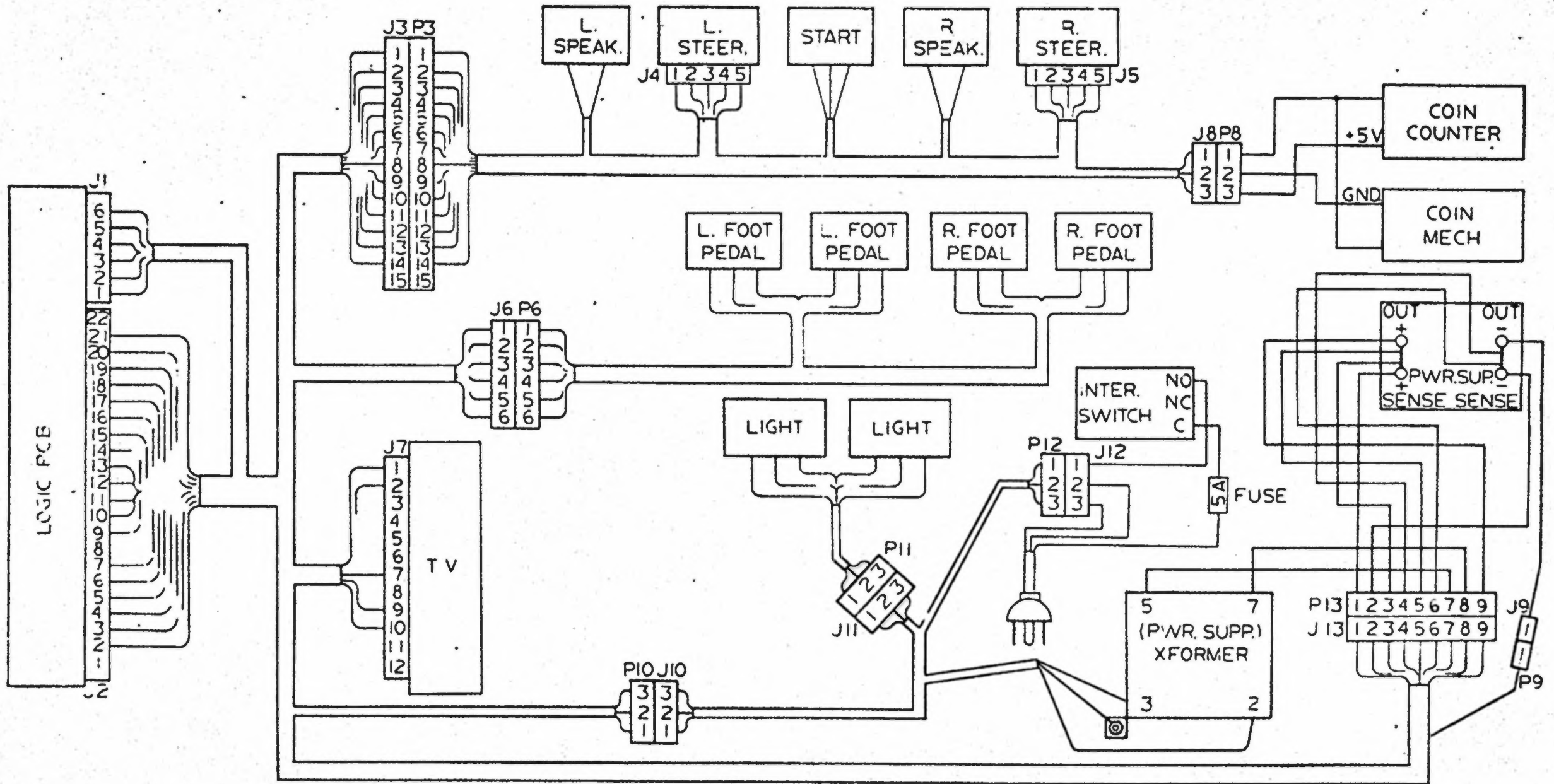

Figure No. 8

FROM:	TO:	FROM:	TO:	FROM:	TO:
J1 (PIN 1)	J13 (PIN 2)	P3 (PIN 11)	Left speaker	J7 (PIN 7)	P10 (PIN 3)
J1 (PIN 2)	J13 (PIN 1)	P3 (PIN 10)	Left speaker	J7 (PIN 10)	P10 (PIN 2)
J1 (PIN 3)	J13 (PIN 7)	P3 (PIN 13)	Right speaker	J7 (PIN 9)	P10 (PIN 1)
J1 (PIN 4)	J13 (PIN 8)	P3 (PIN 12)	Right speaker	J4 (PIN 2)	Start
J1 (PIN 5)	J13 (PIN 9)	P3 (PIN 9)	Start	J4 (PIN 1)	J5 (PIN 1)
J1 (PIN 6)	P9 (PIN 1)	P3 (PIN 14)	J8 (PIN 1)	P3 (PIN 1)	J8 (PIN 3)
J2 (PIN 2)	J3 (PIN 11)	P3 (PIN 5)	J4 (PIN 4)	P3 (PIN 2)	J8 (PIN 2)
J2 (PIN 3)	J3 (PIN 10)	P3 (PIN 4)	J4 (PIN 3)	P8 (PIN 3)	+5 V Coin counter
J2 (PIN 4)	J3 (PIN 13)	P8 (PIN 1)	Coin counter	P8 (PIN 2)	Ground coin mech.
J2 (PIN 5)	J3 (PIN 12)	P6 (PIN 4)	Foot pedal	P11 (PIN 1)	Light
J3 (PIN 9)	J2 (PIN 6)	P6 (PIN 3)	Foot pedal	P11 (PIN 1)	Light
J3 (PIN 14)	J2 (PIN 7)	P3 (PIN 3)	J4 (PIN 5)	P11 (PIN 2)	Light
J2 (PIN 9)	J3 (PIN 5)	P3 (PIN 8)	J5 (PIN 4)	P11 (PIN 2)	Light
J2 (PIN 10)	J3 (PIN 4)	P3 (PIN 7)	J5 (PIN 3)	P11 (PIN 3)	Light w safety ground
J2 (PIN 11)	J6 (PIN 4)	P6 (PIN 6)	Foot pedal	P11 (PIN 3)	Light w safety ground
J2 (PIN 12)	J6 (PIN 3)	P6 (PIN 5)	Foot pedal	J12 (PIN 1)	N.O. inter. switch
J2 (PIN 13)	J3 (PIN 3)	P3 (PIN 6)	J5 (PIN 5)	J12 (PIN 2)	To power cord
J2 (PIN 14)	J3 (PIN 8)	P13 (PIN 5)	+ Out sense	J12 (PIN 3)	To power cord
J2 (PIN 15)	J3 (PIN 7)	P13 (PIN 6)	- Sense	PWR cord	5 AMP fuse
J2 (PIN 16)	J6 (PIN 6)	P13 (PIN 3)	+ Sense	5A AMP fuse	Com. inter switch
J2 (PIN 17)	J6 (PIN 5)	P13 (PIN 4)	- Out	J10 (PIN 1)	J11 (PIN 1)
J2 (PIN 18)	J3 (PIN 6)	J13 (PIN 5)	J3 (PIN 1)	J10 (PIN 2)	J11 (PIN 2)
J7 (PIN 1)	J2 (PIN 20)	J13 (PIN 6)	J3 (PIN 2)	J10 (PIN 3)	J11 (PIN 3)
J2 (PIN 21)	J7 (PIN 2)	J13 (PIN 3)	J6 (PIN 1)	J12 (PIN 3)	Safety ground
P13 (PIN 2)	- Sense (P.S.)	J13 (PIN 4)	J6 (PIN 2)	J12 (PIN 2)	=2 of xformer
P13 (PIN 1)	+ Sense (P.S.)	J13 (PIN 4)	J6 (PIN 2)	J12 (PIN 1)	=3 of xformer
P13 (PIN 7)	#5 of xformer	P3 (PIN 1)	J4 (PIN 1)	J11 (PIN 3)	P12 (PIN 3)
P13 (PIN 8)	#7 of xformer	P3 (PIN 2)	J4 (PIN 2)	J11 (PIN 2)	P12 (PIN 2)
P13 (PIN 9)	+ Out	P6 (PIN 1)	Foot pedal	J11 (PIN 1)	P12 (PIN 1)
J9 (PIN 1)	- Out	P6 (PIN 2)	Foot pedal		



**FIG 9**

**ACCELERATION (FOOT PEDAL) WIRING**

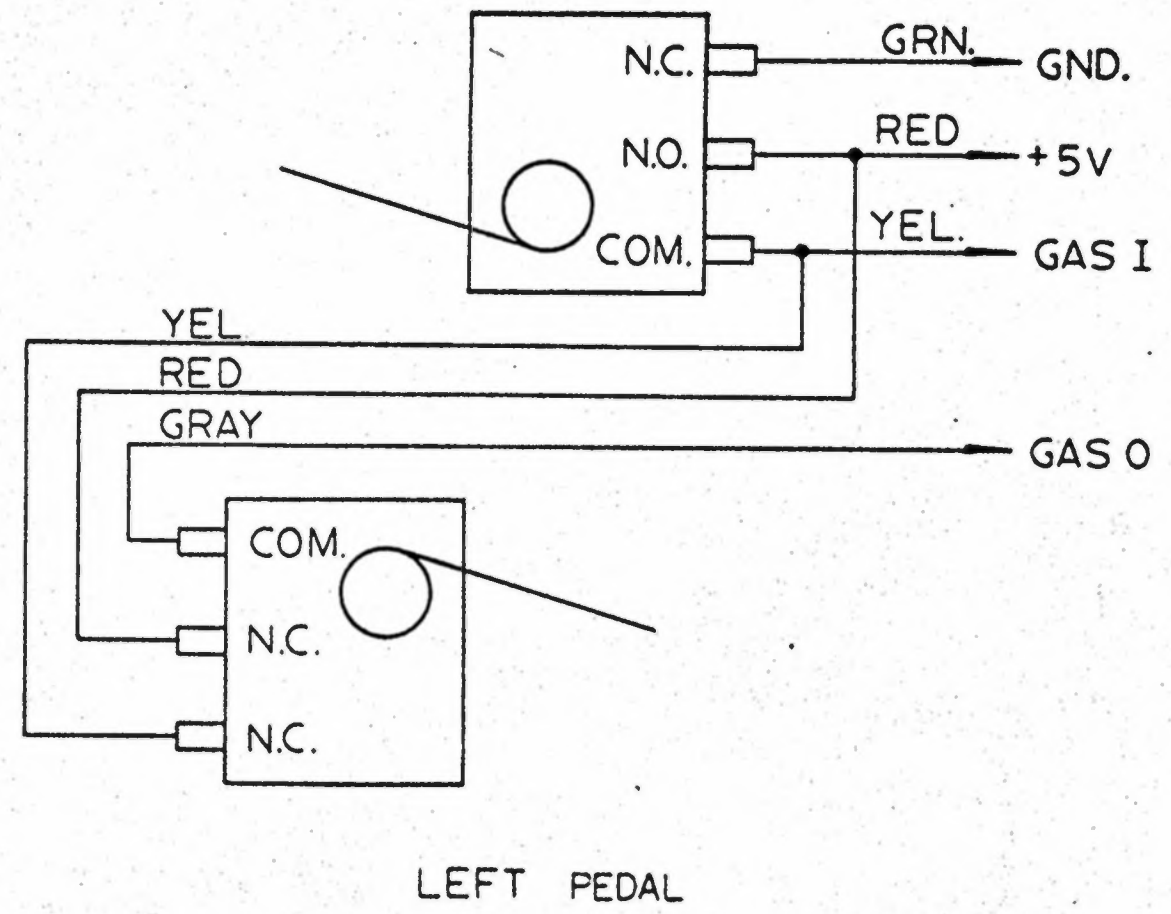
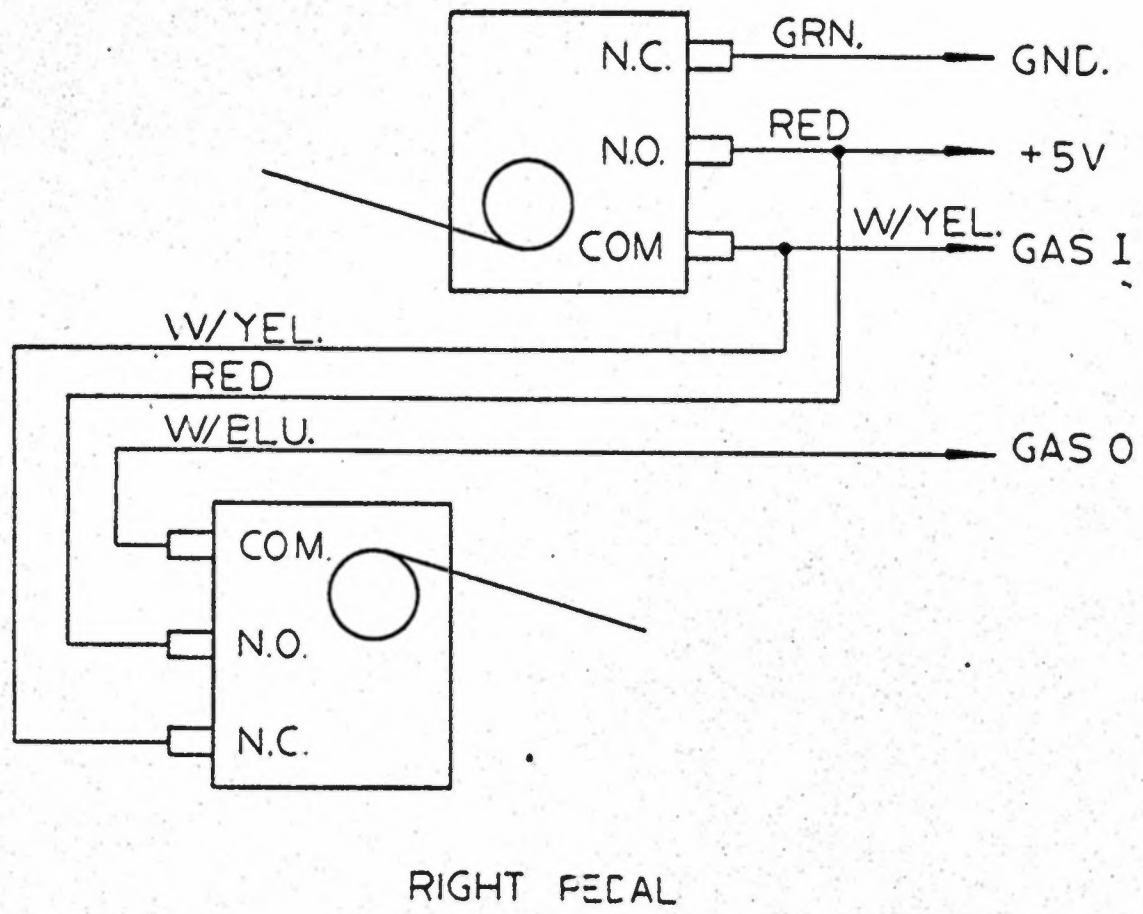

REAR VIEW

23



# FIG 10

## OPTICAL STEERING BOARD SCHEMATIC

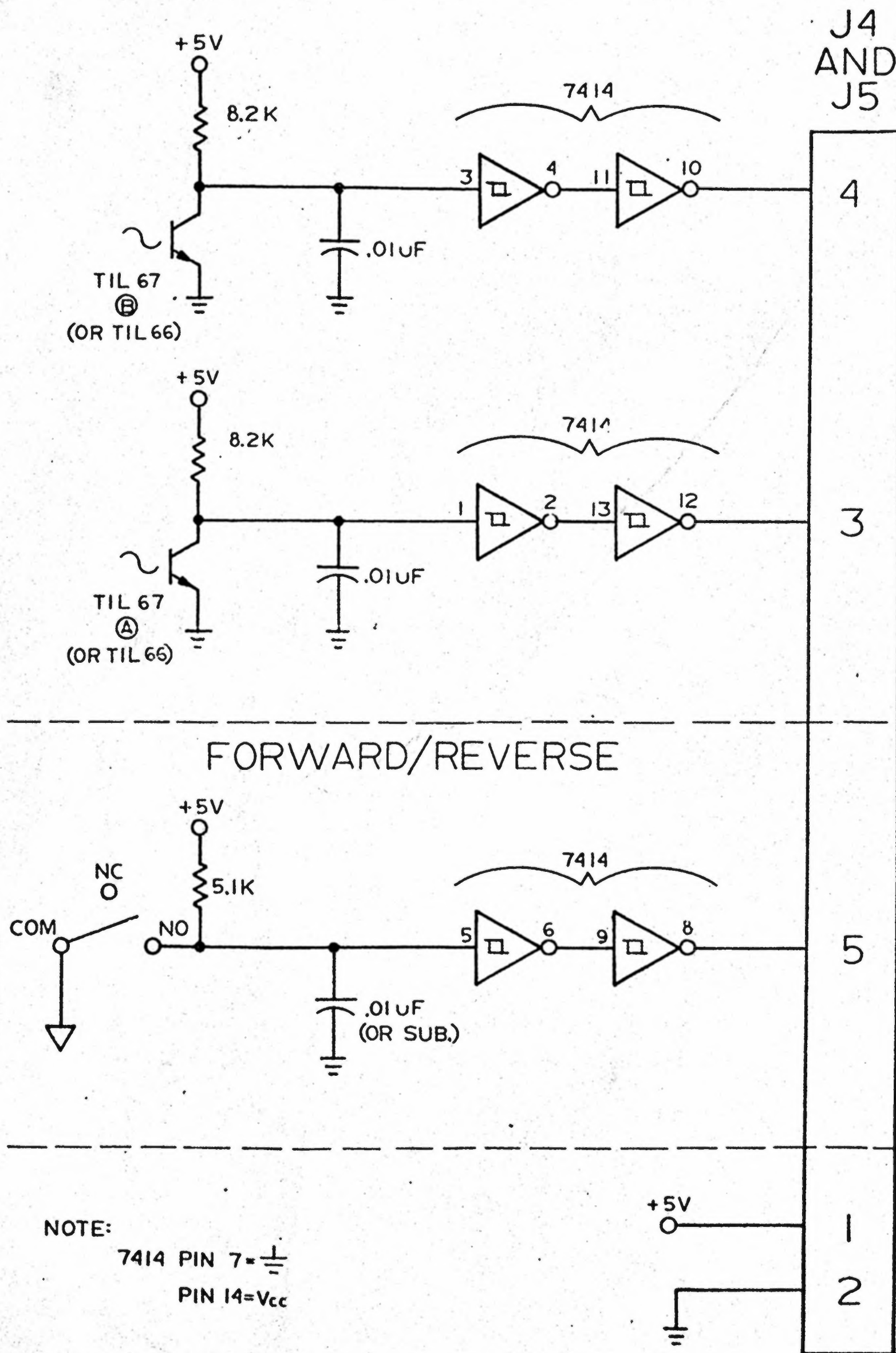



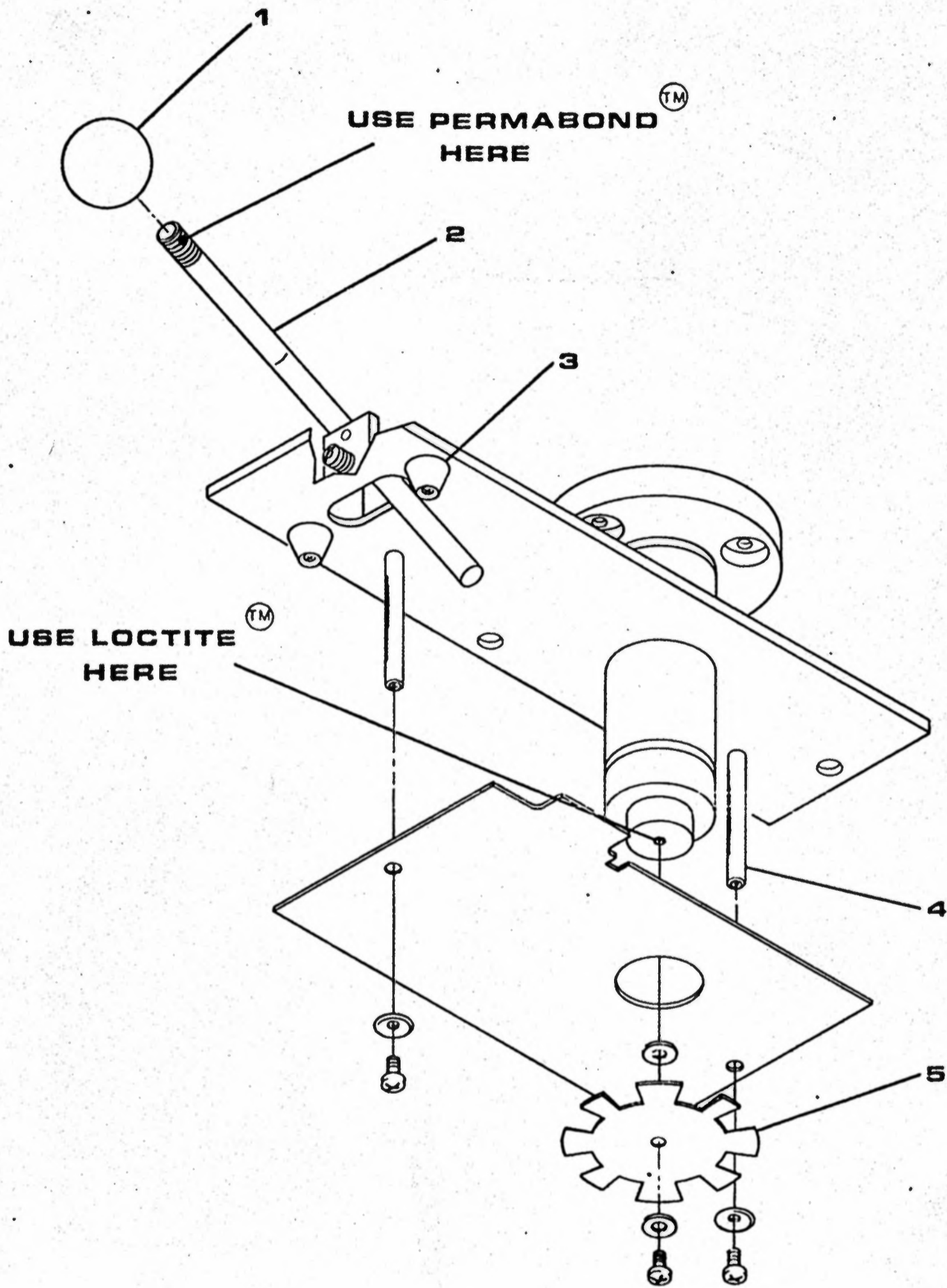

Figure No. 11		EXIDY
ITEM	PART NO.	DESCRIPTION
1.	DR-KN42	Shift Knob
2.	No No.	Shift Lever
3.	DR-2183	Lever Bumper
4.	DR-8351	Stand Off
5.	DR-ST-C8	Steering Mask

