

An explosive new game DEPTHCHARGE

Gremlin's first thematic game is an action-packed, sound sensation that scores a direct hit for repeat play.

Fire one for action
sink the submarines moving below at different speeds.

Fire two for challenge
aim for higher-point, harder-to-hit subs as your skill increases.

Fire three for strategy
launch each depth charge at the right time, right place.

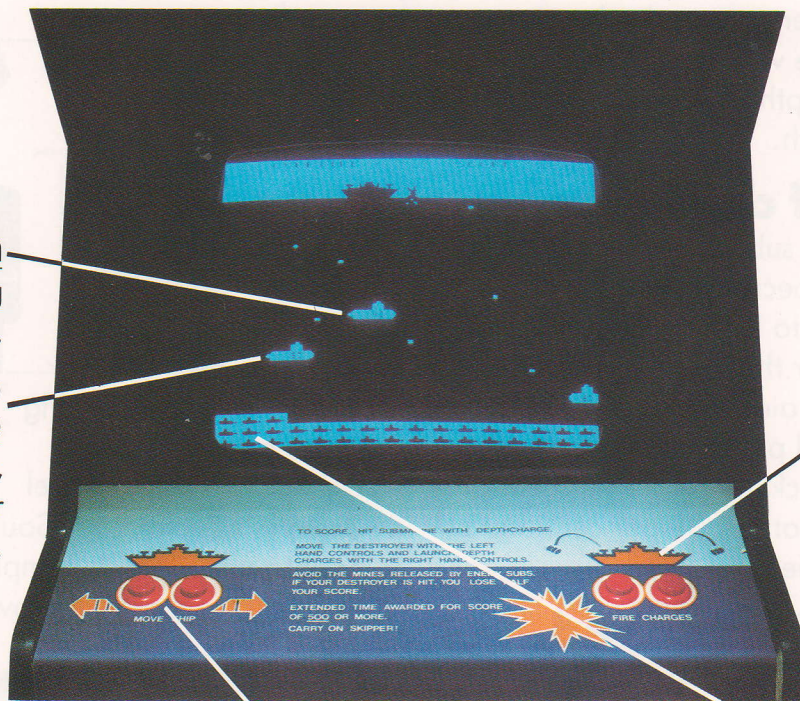

Fire four for defense
steer the ship to avoid random mines that cut your score in half.

Fire five for suspense
add bonus points when time runs out for each sunk-en sub in the "graveyard."

Fire six for incentive
beat the high score to date, recorded on screen between games.



Gremlin®

The games people really play.

No easy shot

The beginning player can have a great time with DEPTHCHARGE. But the more skill he develops, the more challenging it becomes. That's because there's no straight line to the target. With subs moving at different speeds, the player must anticipate where each will be at the time his depth charge reaches that particular depth.

Layers of challenge

The high-score subs near the bottom are hardest to hit because there's much more distance to judge. Also, the low point subs near the surface explode depth charges aimed for high point subs below. A good player can avoid being sunk while knocking out 70 per cent of the subs. It's that last 30 per cent that's hardest to achieve.

New and improved

DEPTHCHARGE could be called DEPTHCHARGE II because this is the second version. The original was ready a year ago but didn't meet high Gremlin standards in arcade tests. So the company spent more time and money to fine tune it, adding another full market test. Now DEPTHCHARGE has all the polished elements that make a good game. Most important—repeat play.

Sound sensation

One of the biggest features of DEPTHCHARGE is the spectacular explosion, sinking and water sounds. Its sonar is particularly realistic. And Gremlin is the only game company to make volume control easily accessible in the front panel. Because if the sound can't be turned down, too often it's turned off. And that's a big part of the game wasted.

Other features:

19" solid state TV monitor.

Power: AC, 100V-115V-230V, 50/60 Hz, 130 watts. 3-wire cord with safety interlock on game access door.

Grounding required. Weight: 290 pounds.

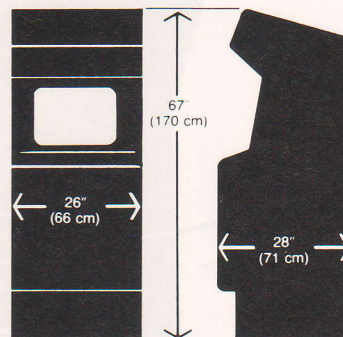

Anti-cheat programming
Dual coin mechanism
E-Z Adjust control panel
Gremlin's Surround-A-Sound
Easy-to-understand, complete maintenance manual provided with every game.



E-Z Adjust control panel

Gremlin®

The games people really play.

Gremlin Industries, Inc.
8401 Aero Drive, San Diego, CA 92123
(714) 277-8700

Exclusive International Distributor:
Belam Export Corporation
51 Madison Ave., New York, NY 10010

Cable: BELAMEX NEWYORK
New York Telex: RCA 223333
Telephone: (212) 689-5632