

S.M.L.



DESERT PATROL



OPERATOR'S MANUAL



PROJECT SUPPORT ENGINEERING
750 NORTH MARY AVENUE
SUNNYVALE, CA. 94086
408-739-8550

TABLE OF CONTENTS

I.	INTRODUCTION.....	1
II.	GAME OPERATION.....	2
	1. Power on.....	2
	2. Credit.....	2
	3. Game Start.....	2
	4. Game Action.....	2
III.	DESERT PATROL MAJOR SECTIONS.....	3
	1. Power Supply.....	3
	2. Logic Boards.....	3
	3. Calibration Panel.....	3
	4. Wiring Harness.....	3
	5. Machine Gun.....	4
	6. Front and Back View of Game.....	5
IV.	GAME LOGIC.....	6
	A. Introduction.....	6
	B. Theory of Operation.....	7
	1. Board 1.....	7
	2. Board 2.....	7
	3. Board 3.....	8, 9, & 10
V.	ILLUSTRATED PARTS BREAKDOWN.....	11
	A. Desert Patrol Anti-Aircraft Gun Exploded View.....	11
	B. Parts List.....	12, 13, 14, 15, 16
VI.	ADJUSTMENTS.....	17
VII.	TABLES AND REFERENCES.....	18
	A. Prom 1 Address Map.....	18
	B. Prom 2 Address Map.....	18
	C. 32 X 8 Prom Data.....	19
	D. Image RAM Data 16 X 16.....	19
	E. Edge Connector Pin Index.....	20
	1. Board 1.....	20
	2. Board 2.....	21
	3. Board 3.....	22
	F. Strokes.....	23
	G. Conditions.....	24
	H. Score RAM Data.....	25
	I. Board Layout.....	26
	1. Board 1.....	26
	2. Board 2.....	27
	3. Board 3.....	28
VIII.	SCHEMATICS.....	29
	A. Board 1.....	29 & 30
	B. Board 2.....	31 & 32
	C. Board 3.....	33 & 34
	D. Monitor Schematic.....	35
	E. Wiring Harness and Wire List.....	36
IX.	GAME SERVICE ADDRESS.....	37

INTRODUCTION

Desert Patrol is a completely solid state video game which utilizes state-of-the-art semiconductor components. The game display and logic sequence are generated by three printed circuit boards. A 23-inch video monitor displays the game picture, and an advanced sound generation system adds realistic sounds to complete the environment.

Desert Patrol is a game for one player who controls an anti-aircraft machine gun. Points are scored by shooting down the target airplane while successfully avoiding the falling parachutes.

In this manual you will find a description of the game sequence of play and an explanation and location of all game adjustments. There are also sections detailing the logic of the game and providing troubleshooting assistance in case of problems.

GAME OPERATION

1. POWER ON After an initial warm-up period, the game display will appear on the screen.
 - a. Various types of aircraft will appear randomly and fly across the screen.
 - b. There are six different types of aircraft which will appear randomly. Each aircraft has its own point value and speed.
 - c. In the ground display, a 5 digit high score value of 00000 will appear on the left side. The timer will display 000 in the middle, and the 5 digit player's score value of 00000 will be displayed on the right.
 - d. The words "Game Over" will be displayed above the high score.

2. CREDIT Credit is established by inserting one coin (see game adjustments section for 2 coin credit).
 - a. The timer will set to 100.
 - b. The players score will set to 00000.

3. GAME START Game Start is automatic after coin is inserted.
 - a. The player now has control of the machine gun.
 - b. Game sounds will be evident, including the airplane engines, jet, explosion, and paratrooper's scream.
 - c. The words "Game Over" will disappear from the display.
 - d. The timer will begin counting down.

4. GAME ACTION The machine gun can be positioned, aimed, and fired by the player.
 - a. Aim and fire the machine gun to hit the aircraft. A small shot explosion will appear on the screen when the gun is fired. The machine gun barrels will also move back and forth.
 - b. If an aircraft is hit, a large explosion image will be displayed with an explosion sound. The point value for that image will be added to the player's score. After the explosion has been displayed, the image of a man and parachute will appear and start dropping toward the ground. The parachute image will swing back and forth as it falls.
 - c. If the parachute is hit, 1000 points are subtracted from the player's score. The word "Penalty" appears above the player's score, and the player loses firing ability for a short time. The sound of a scream is heard and a falling man appears where the parachute was. The man will rotate as he falls to the ground.
 - d. The game proceeds until the timer reaches 000. The timer then stops, and if the player's score exceeds the high score, the new high score will be displayed. The words "Game Over" will reappear on the left.

DESERT PATROL MAJOR SECTIONS

1. POWER SUPPLY The power supply for this board produces regulated +5 and regulated -12. The line voltage is applied to the primary of the power transformer through a line voltage selection switch. The secondaries of the transformer produce 8.5 VAC and 26 VAC center tapped.

The 8.5 VAC is full wave rectified by the 5 volt rectifier. The unregulated +10V is filtered by a 9,000 uF capacitor regulated down to +5 volts by the 2N3055 power transistor which is heat sunked on the rear of the card guide. The base of the 2N3055 is controlled by a 741 OP AMP which is ZENER diode referenced to supply a stable 5 volt supply.

The 26 VAC is full wave rectified by the 12 volt bridge to produce -23VDC. A 100 uF capacitor filters the - supply which is then regulated down to -12VDC by a LM320T-12 voltage regulator. A 9600 uF capacitor filters the +supply which is then regulated down to +12VDC by a LM 340T-12 voltage regulator.

2. LOGIC BOARDS Refer to game logic section for a detailed explanation.
 - a. Board 1: Board 1 produces all the timing signals for the game. SYNC, horizontal and vertical counters and program control are also on board 1.
 - b. Board 2: Board 2 is responsible for generating all the game images. Image locations, motion, and collisions also involve board 2 circuitry.
 - c. Board 3: Board 3 contains the coin in, timer, audio, and shot generation circuitry.

3. CALIBRATION PANEL

- a. The calibration panel has 4 pots and a toggle switch. The 4 pots are used to set the top, bottom, left and right shot boundaries. The toggle switch will switch on a calibration display for aligning the shot.

4. WIRING HARNESS Refer to wiring harness diagram. The game contains two separate harnesses.

- a. Power Harness: This harness provides interconnects between the line cord, line voltage select switch, power transformer, and monitor.
- b. Main Harness: This harness provides interconnects between the motherboard, speakers, coin door components, calibration panel, machine gun, and control panel switches.

MACHINE GUN

The machine gun is pointed at the target; when the target is sighted, a trigger button is pressed on the right handle to fire and the shot will appear on the screen. The machine gun can be maneuvered and fired at any part of the screen, following the target. The start switch is located on front of the machine gun.

SERVICE:

Remove cover, and grease and oil gears and other moving parts, at least once a month.

Gears are installed with lock-tight. To remove, expose to heat for approximately 30 seconds. Using a match will do sufficiently.

OPERATION:

Barrel Action

The barrels are moved through a series of gears, eccentrics and levers. A 115V A.C.-D.C. 60 HZ 1/15 HP motor drives the main gear which rotates the eccentric shaft. As the eccentric shaft rotates, it pushes and pulls the connecting rod. The connecting rod is connected to the crank arm on the switch side. The crank arm's fulcrum is the center, creating a push-pull action to the barrel link, which is attached to the barrels with the barrel pins.

HORIZONTAL AND VERTICAL MOVEMENT

Vertical Movement

The pivot point for vertical movement is on the altitude pivot shaft, and the main support bracket. As the main support bracket is moved up or down, a pinion gear is driven from the altitude pivot shaft gear. The pinion gear is attached to a 0 to 100K ohm variable pot, which signal controls the vertical movement of the machine gun fire on the monitor.

Horizontal Movement

Horizontal Movement is through the inner support shaft on top of the main support shaft, by the altitude pivot shaft. The inner support shaft gear, drives a pinion gear attached to a 0-100k ohm variable pot, which signal controls the horizontal sweep of gun-fire on the monitor. A steel roll pin below the inner shaft gear controls the amount of machine gun pivot.

MACHINE GUN REMOVAL

1. Unplug power.
2. Disconnect 2 plugs coming from main support shaft.
3. Slip off C ring.
4. Pull straight up.
5. Reverse procedure for reinstallation.

4

3

2

1

REVISIONS			
ISSUE	DESCRIPTION	DATE	APPROVAL

D

C

5

B

A

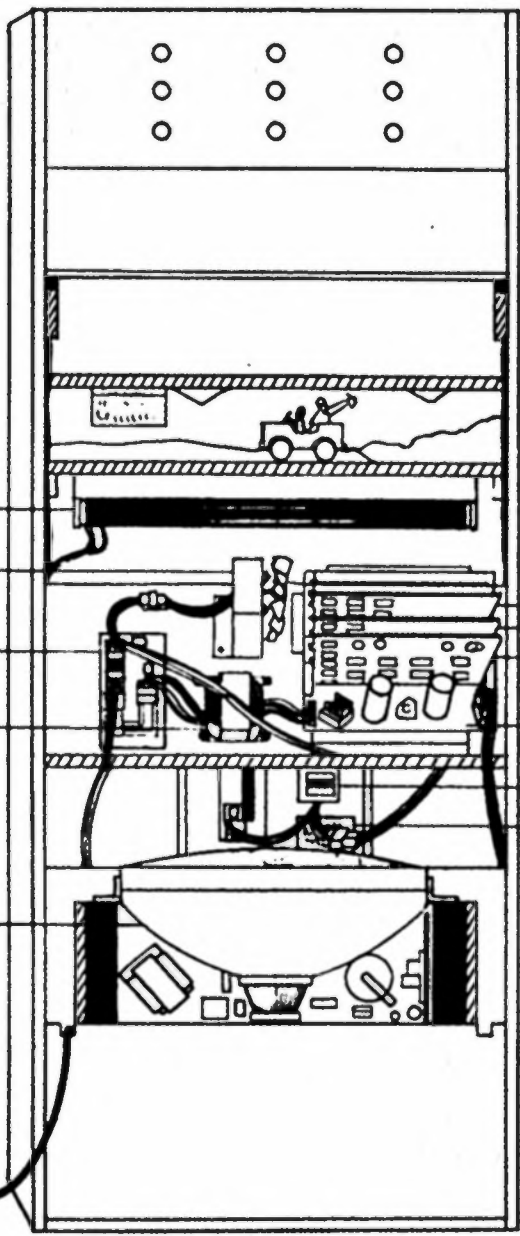

- BLACK LIGHT
- FAN
- LINE SELECT BOARD
- TRANSFORMER
- MONITOR ASSEMBLY
- PLUG

- PC 1
- PC 2
- PC 3
- MOTHERBOARD
- COUNTER
- PSE SERIAL NUMBER



- BANNER
- SPEAKER
- FRONT BEZEL
- MACHINE GUN
- BASE CONE
- COIN DOOR
- COIN ACCEPTOR

- CALIBRATION PANEL
- COIN BOX
- STEP

	TITLE DESERT PATROL FRONT & BACK VIEW		APPROVED INT. DATE DRAWN 3/19/77	
	PROJECT SUPPORT ENGINEERING 780 NORTH MARY AVENUE SUNNYVALE, CALIFORNIA 94088 PHONE: (408) 739-8888		CHECKED DESIGNER PROJ. ENG.	
DRAWING NO.		SCALE		SK 1 OF 1

4

3

2

1

GAME LOGIC

INTRODUCTION

The P.C. boards are accessible through the rear door of the cabinet. To facilitate identification of integrated circuits, a grid system of letters and numbers is marked on each board. The grid system of identification is marked on the circuit element on the schematics. The 7400 series logic identification has been abbreviated by deletion of the 74; e.g. "85" refers to a 7485.

The logic gates are drawn as boxes instead of logic symbols on the schematics. This system allows for fast and accurate troubleshooting. The inputs come in on the left side of the box, and the output leaves from the right side. A 2 digit number and letter in a box is the grid location on the P.C. board. The polarity and letters in the box refer to the gate's logic function; e.g. +AI tells you that the gate is performing a positive AND-INVERT logic function. The following symbols are used to represent standard logic functions:

+ positive true logic

- negative true logic

A and

I invert

0 OR

⊕ exclusive OR

FF flip flop

LTCH latch

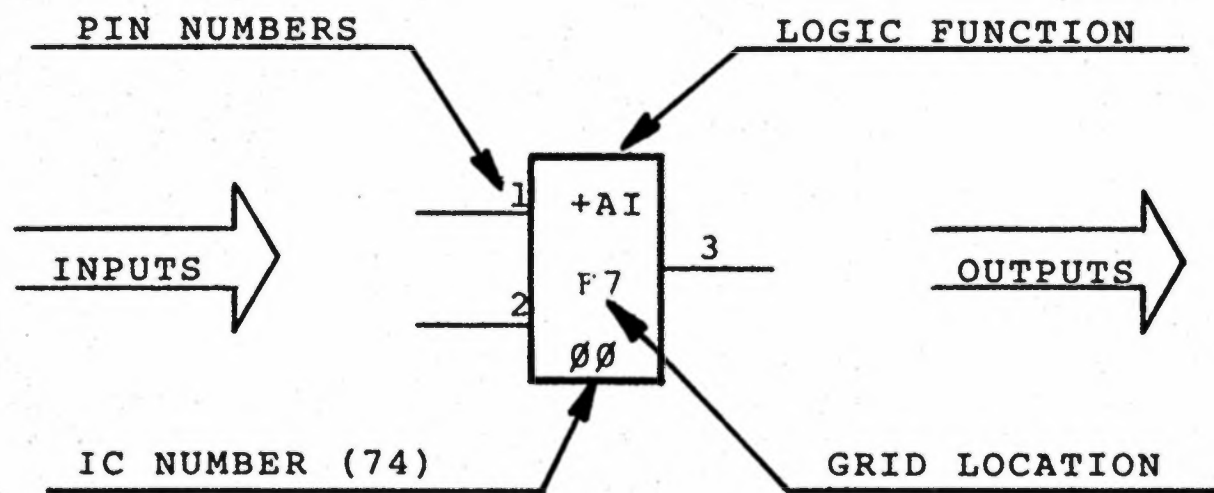

D type flip flops are drawn with this standard format.

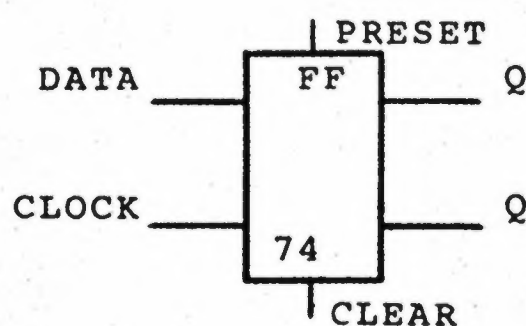

THEORY OF OPERATION

The Desert Patrol game utilizes PSE's high speed processing technique. The game is programmable, that is, all game functions are controlled through a central processing section. This processing section is found on Board 1. The system operates in a similar manner as a microprocessor chip.

BOARD 1

The computer program for the game is held in the two PROMS on board 1, (location E2 and D2). Three four bit binary counters (L3, K3, J3) form the program counter which addresses the PROMS. The instruction address that appears on Data Bits 1-16.2 74154's (E4, D4) decode the instruction to produce the appropriate strobe. The strobe signal is a pulse approximately 300 nano-seconds long. Each of the 32 strobos controls a part of the hardware circuitry.

B2 and B4 (8130's) compare the PROM data with bit and line addressed to synchronize the program with the real time T.V. display. These comparators are mainly used to display the scores.

The score values are stored in a 16 X 4 RAM (L8). (See score RAM data table) This RAM is addressed by a 74193 (K8). The value in the RAM is decoded into the 7 segment format by a 7448 (J7). Each segment is selected for display by the 3-4 bit latches (F7, E7, D7). The 74151 (H7) selects and inputs the appropriate segment on the video line for display. The 74193 (K7) is used to add or subtract from the score values. The 7485 (L7) is used to compare scores to enable high score and game over functions to operate.

Sheet 2 schematic of board 1 contains drawings of the sync circuitry and bit and line counters.

BOARD 2

The board 2 circuitry generates the images for the game. The computer program which operates on board 1 controls the image locations on the screen.

There are 4 16 X 4 RAMs on board 2 organized to produce a 16 X 16 RAM memory. The program loads the appropriate image location in the correct RAM address. (See image RAM data sheet)

The RAMs are addressed by a 74193 (D5). A random logic circuitry scans through the address in the RAMs for a given image. A line start pulse can be produced. This pulse occurs on the first line on which the image is to be displayed. This pulse sets a flip flop (H4, J1), which enables the image generation circuitry.

The 4 74S200 RAMs are organized to produce a memory array of 256 words by 4 bits. In Desert Patrol, there are 4 different levels that images may appear at. Each of these 4 RAMs correspond to one of these levels. The bit address for the image on that level is loaded in the RAM. The entire RAM is cleared during vertical drive. For example, if an image is to appear at bit address 128, the program takes the bit address for that image (128) out of the 16 X 4 RAMs (AT, B7, L7, D7), and addresses the 256 X 4 RAMs to that location (128). A one (1) is written into that location. During display, the 256 X 4 RAMs are addressed directly from the bit counters. When a logic 1 appears out of RAM, it is channeled and selected through the 74279's (J8, K8), and produces a bit start pulse.

There are two image prom circuits for this game. Prom 1 (L4) contains all the target aircraft images as well as the explosion image. Prom 2 (L1) contains the various positions of the parachute and the falling man. The 74161 (H6) and 7474 (J3) create the bit address for the image. Five 7486's (H5, J6) can invert the bit address to change the direction that the image faces. The 74151 (J5) converts the 8 bit image word into serial form for video display.

The Prom 2 (L1) circuit is the same as the Prom 1 circuit, except that there are no 7486's to invert the bit address.

Image motion is carried out under program control. Two 7483 (A4, B4) 4 bit adders add the image address to the speed number every frame to move the image. When a carry or a borrow is produced from the address, an end of travel (condition 11) is produced. The program senses this line to switch images when it reaches the screen border.

A 74161 (A5) counter is clocked off the first 7483 adder output to produce a random count. This counter counts from 0 - 6. The program will take this random number and load it into the 16 X 16 RAM to create a new random image. A 32 X 8 PROM (H7) contains PROM address codes and image speeds. Each image has its own speed and address block in the image PROM. (See 32 X 8 PROM data table.)

There are two 74150's (B9, C9) on board 2. The program controls this circuit so that any of the 32 input lines, or CONDITIONS, can be selected down to one COND. OUT line. Conditions are inputs to the program. By sensing these outputs (conditions 16-23), the program is able to switch to explosion, parachute, and man images at appropriate times.

BOARD 3

Board 3 contains coin-in, shot generation, and audio circuitry. The coin switch gets debounced by the two 7400 (J9) gates. The output of this latch configuration triggers a 74123 (J8) one shot.

The output of the 74123 clocks a 7474 flip flop (H9), providing the coin-in signal is still present. The 7474 (H9) is used to count two coins. The coin-in signal is clocked through a 7474 (F6) to initialize the game for proper score and image display. A switch will select one or two coins through a 7400 (E9, F9) multiplexer circuit. The selected credit signal is applied to one input of a 7400 latch. When the start switch is pressed, the latch is set, and a game-on condition exists. The program will generate a strobe 30 when the timer is at 000 to reset the coin-in flip flops to end the game. The high score clear switch gets clocked through a 7474 (K9) and creates a low on condition 1. The program senses condition 1 every frame, so that when this condition goes low, the high score will clear. A 74123 (J8) is used as a power on reset (POR). When power is applied, the one shot will fire and condition 9 will reset the game.

The shot circuitry generates the small shell explosion image and positions this image on the screen. A transistor circuitry generates a constant current ramp. This ramp is compared to the H location voltage. The horizontal position put on the machine gun axis varies from 1.5 to 2.5 volts. The LM339 (B8) comparator output latches the 74174 (D7) latch. The 7485 comparator (E7) generates the horizontal shot position. The vertical position portion is identical in concept to the horizontal position circuitry. The 7485 comparator (B7) output generates the vertical window. ANDing the vertical and horizontal windows generates an 8 bit by 8 line shot window. 7486's and 7402's (C7, E8) generate the shell explosion image.

The game time uses an NE555 (A8) timer chip in a one shot configuration. The program senses condition 6 every frame. When this condition goes high, the program decrements the timer value by 1, and retriggers the NE555 with strobe 28. The time adjustment pot determines the length of the NE555's output pulse.

The airplane audio is generated by two NE555's (C2, D2). One 555 resets the other, producing a pulsating frequency to simulate the airplane motor sound.

The scream sound is generated by reading out data from a 256 X 4 PROM (D1) and performing a digital to analog conversion. The data in the PROM is organized to produce the waveform of a human scream. Two 7493 (B1, C1) counters which are clocked by a NE555 address the PROM. A transistor circuit creates a linear ramp which controls the 555 frequency. A 100K r-pack performs the D-A conversion.

The jet and explosion audios are similar. Both use 74164 shift registers with exclusive OR tie backs. This produces random white noise. The jet frequency is controlled by a linear ramp circuitry. This ramp also controls the volume for the jet. The volume decay for the explosion is controlled by a capacitor discharging.

The various audio sounds are mixed through resistors into two separate LM380 push-pull audio amplifiers which will provide at least six watts of power per channel.

A 74174 (D6) latches the audio enable signals for airplane, helicopter, and jet. The enabling sequence is carried out under program control. A random logic circuitry decodes the appropriate audio for a given image.

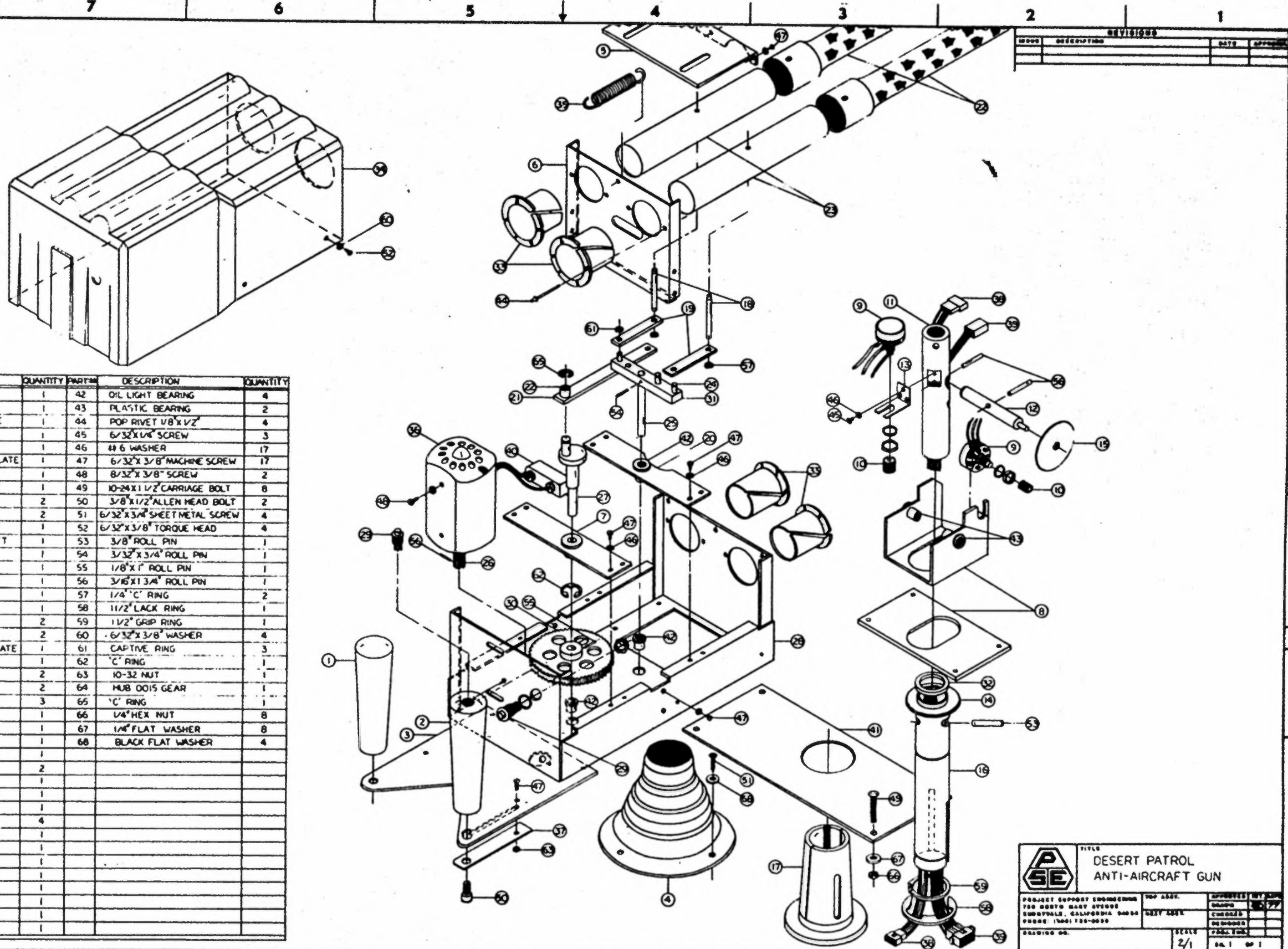

PARTS LIST

PART#	DESCRIPTION	QUANTITY	PART#	DESCRIPTION	QUANTITY
01	HANDLE (LEFT)	1	42	OIL LIGHT BEARING	4
02	HANDLE (RIGHT)	1	43	PLASTIC BEARING	2
03	HANDLE MOUNTING PLATE	1	44	POP RIVET 1/8" X 1/2"	4
04	BASE CONE	1	45	6/32" X 1/4" SCREW	3
05	BARREL GUIDE	1	46	# 6 WASHER	17
06	INTERMEDIATE BARREL PLATE	1	47	6/32" X 3/8" MACHINE SCREW	17
07	BEARING PLATE	1	48	8/32" X 3/8" SCREW	2
08	MAIN SUPPORT BRACKET	1	49	10-24 X 1 1/2" CARRIAGE BOLT	8
09	POT	2	50	3/8" X 1 1/2" ALLEN HEAD BOLT	2
10	POT PINION GEAR	2	51	6/32" X 3/4" SHEET METAL SCREW	4
11	INNER MOUNTING SHAFT	1	52	6/32" X 3/8" TORQUE HEAD	4
12	ALTITUDE SUPPORT SHAFT	1	53	3/8" ROLL PIN	1
13	POT BRACKET	1	54	3/32" X 3/4" ROLL PIN	1
14	HORIZONTAL GEAR	1	55	1/8" X 1" ROLL PIN	1
15	VERTICAL GEAR	1	56	3/16" X 1 3/4" ROLL PIN	1
16	OUTER MOUNTING SHAFT	1	57	1/4" 'C' RING	2
17	MOUNTING COLLAR	1	58	1 1/2" LACK RING	1
18	BARREL PIN	2	59	1 1/2" GRIP RING	1
19	BARREL LINK	2	60	6/32" X 3/8" WASHER	4
20	CRANKSHAFT BEARING PLATE	1	61	CAPTIVE RING	3
21	CONNECTING ROD	1	62	'C' RING	1
22	GUN BARREL EXTENSION	2	63	10-32 NUT	1
23	GUN BARREL	2	64	HUB 0015 GEAR	1
24	LINK PINS	3	65	'C' RING	1
25	CRANKSHAFT	1	66	1/4" HEX NUT	8
26	MOTOR PINION	1	67	1/4" FLAT WASHER	8
27	ECCENTRIC SHAFT	1	68	BLACK FLAT WASHER	4
28	GUN CHASSIS	1			
29	SWITCH-PUSHBUTTON	2			
30	MAIN DRIVE GEAR	1			
31	CRANK ARM	1			
32	THRUST WASHER	1			
33	PLASTIC GROMMET	4			
34	GUN COVER	1			
35	SPRING	1			
36	MOTOR	1			
37	WIRE COVER	1			
38	MOTOR HARNESS	1			
39	SIGNAL HARNESS	1			
40	LINE FILTER	1			
41	MOUNTING PLATE	1			

DESERT PATROL ANTI-AIRCRAFT GUN

PROJECT SUPPORT ENGINEERING
700 NORTH MAIN AVENUE
SUNNYVALE, CALIFORNIA 94086
PHONE: (408) 730-0000

DATE: 10/1/77
DRAWING NO.: 2/1
PAGE: 1 OF 1

PARTS LIST

DESCRIPTION	PART NUMBER	
Motherboard	05-001-X001	(complete board)
PC 1	05-001-X002	(complete board)
PC 2	05-001-X003	(complete board)
PC 3	05-001-X004	(complete board)
Line select board	05-001-X005	(complete board)
Calibration panel	05-001-X006	(complete board)
Line select board	05-001-0005	
Calibration panel	05-001-0006	
Power harness	04-002-0001	
Signal harness	04-002-0002	
36 Pin male plug	05-002-0001	
36 Pin female plug	05-002-0002	
12 Pin male plug	05-002-0003	
12 Pin female plug	05-002-0004	
9 Pin male plug	05-002-0005	
9 Pin female plug	05-002-0006	
6 Pin male plug	05-002-0007	
6 Pin female plug	05-002-0008	
3 Pin male plug	05-002-0009	
3 Pin female plug	05-002-0010	
12 Pin inline plug male	05-002-0011	
12 Pin inline plug female	05-002-0012	
43 Pin edge connector	05-002-0013	
12 Pin MOTOROLA plug male	05-002-0014	
MOTOROLA pins male	05-003-0001	
Crimp pin male .062	05-003-0002	
Crimp pin female .062	05-003-0003	
Crimp pin male .093	05-003-0004	
Crimp pin female .093	05-003-0005	
Solder pin male .062	05-003-0006	
Solder pin female .062	05-003-0007	
Solder pin male .093	05-003-0008	
Solder pin female .093	05-003-0009	
100K pot	05-004-0002	
5K pot	05-004-0003	
1 meg pot	05-004-0004	
2 ohm ½W	05-005-0001	
100 ohm ½W	05-005-0002	
200 ohm ½W	05-005-0003	
470 ohm ½W	05-005-0004	
1K ohm ½W	05-005-0005	
1.5K ohm ½W	05-005-0006	
1.8K ohm ½W	05-005-0007	
2K ohm ½W	05-005-0008	
3.3K ohm ½W	05-005-0009	
4.7K ohm ½W	05-005-0010	
6.8K ohm ½W	05-005-0011	

10K ohm 1/2W	05-005-0012
15K ohm 1/2W	05-005-0013
18K ohm 1/2W	05-005-0014
24K ohm 1/2W	05-005-0015
33K ohm 1/2W	05-005-0016
47K ohm 1/2W	05-005-0017
100K ohm 1/2W	05-005-0018
220K ohm 1/2W	05-005-0019
300K ohm 1/2W	05-005-0020
510K ohm 1/2W	05-005-0021
1 meg ohm 1/2W	05-005-0022
2N3055 Trans.	05-006-0001
RCA40347 Trans.	05-006-0002
2N3643 Trans.	05-006-0003
2N3644 Trans.	05-006-0004
195-K-1 Transformer	05-007-0001
52118 Pulse Transformer	05-007-0002
IN764 Diode	05-008-0001
IN914 Diode	05-008-0002
IN4001 Diode	05-008-0003
.001uF 50V Cap.	05-009-0001
.01uF 50V	05-009-0002
.01uF 50V mono	05-009-0003
.1uF 50V mono	05-009-0004
10uF 16V radial electro.	05-009-0005
100uF 16V	05-009-0006
100pF 50V mono	05-009-0007
100uF 35V	05-009-0008
.002uF 50V mono	05-009-0009
2.2 tantalum 25V	05-009-0010
2.2uF 16V radial electro.	05-009-0011
22uF 16V radial electro.	05-009-0012
.003 mono	05-009-0013
.047 16V	05-009-0014
.47uF 25V radial electro.	05-009-0015
20uF 50V	05-009-0016
1800pF mono	05-009-0017
560pF	05-009-0019
15 uF	05-009-0020
470pF dip mica radial	05-009-0021
100pF	05-009-0022
96mF 25V	05-009-0023
4116-002-104 R pack	05-010-0001
4114-001-102 R pack	05-010-0002
4114-002-472 R pack	05-010-0003
4114-001-472 R pack	05-010-0004
4114-001-103 R pack	05-010-0005
4116-001-472 R pack	05-010-0006
4116-001-102 R pack	05-010-0007
74LS367 IC	05-011-0001
74LS00	05-011-0002
74LS02	05-011-0003
74LS04	05-011-0004

74LS08	05-011-0005
74LS10	05-011-0006
74LS11	05-011-0007
74LS20	05-011-0008
74LS30	05-011-0009
74LS32	05-011-0010
74LS42	05-011-0011
74LS48	05-011-0012
74LS54	05-011-0013
74LS74	05-011-0014
74LS83	05-011-0015
74LS85	05-011-0016
74LS86	05-011-0017
74LS92	05-011-0018
74LS93	05-011-0019
74LS107	05-011-0020
74LS123	05-011-0021
74150	05-011-0022
74LS151	05-011-0023
74LS157	05-011-0024
74LS155	05-011-0025
74LS158	05-011-0026
74LS161	05-011-0027
74LS164	05-011-0028
74189 or MM6561	05-011-0029
74LS191	05-011-0030
74LS192	05-011-0031
74LS193	05-011-0032
74LS174	05-011-0033
74LS568	05-011-0034
74LS200	05-011-0035
74LS279	05-011-0036
LM380	05-011-0037
DM8098	05-011-0038
74367 or DM8097	05-011-0039
DM8130	05-011-0040
LM555	05-011-0041
DM8553	05-011-0042
MM5320	05-011-0043
LM741CN	05-011-0044
LM320T-12	05-011-0045
LM339	05-011-0046
LM340T-12	05-011-0047
N82S141N or 6341-1	05-011-0048
N82123F	05-011-0049
8574 or MM6301-0J	05-011-0050
3262A	05-011-0051
16 Pin IC socket	05-012-0001
24 Pin IC socket	05-012-0002
GE SC141D Triod	05-012-0003
Bridge MDA990-1	05-012-0004
Bridge MDA970-1	05-012-0005
Crystal 14.31818	05-012-0006

	Fuse Clip	05-012-0007
	Slide Switch	04-003-0002
	Special Slide Switch	04-003-0003
	Fuse 312003	05-013-0001
	Fuse 313125	05-013-0002
01	Handle Left	02-008-0001
02	Handle Right	02-008-0002
03	Handle Mounting Plate	01-HMP-0001
04	Base Cone	01-XBC-0002
05	Barrel Guide	01-XBG-0003
06	Intermediate Barrel Plate	01-IBP-0004
07	Bearing Plate	01-XBP-0005
08	Main Support Bracket	01-MSB-0006
09	Pot	05-003-0001
10	Pot Pinion Gear	01-PPG-0007
11	Inner Monitor Shaft	01-IMS-0008
12	Altitude Support Shaft	01-ASS-0009
13	Pot Bracket	01-XPB-0010
14	Horizontal Gear	01-XHG-0011
15	Vertical Gear	01-XVG-0011
16	Outer Mounting Shaft	01-OMS-0012
17	Mounting Collar	01-XMC-0013
18	Barrel Pin	01-XBP-0014
19	Barrel Link	01-XBL-0015
20	Crankshaft Bearing Plate	01-CBP-0016
21	Connecting Rod	01-XCR-0017
22	Gun Barrel Extension	01-GBE-0018
23	Gun Barrel	01-XGB-0019
24	Link Pins	01-XLP-0020
25	Crank Shaft	01-XCS-0021
26	Motor Pinion	01-XMP-0022
27	Eccentric Shaft	01-XES-0023
28	Gun Chassis	01-XGC-0024
29	Switch Push Button	04-003-0001
30	Main Drive Gear	02-002-0001
31	Crank Arm	01-XCA-0025
32	Thrust Washer	01-XTW-0026
33	Plastic Grommet	02-001-0001
34	Gun Cover	01-XGC-0027
35	Spring	02-008-0003
36	Motor	04-001-0001
37	Wire Cover	01-XWC-0028
38	Motor Harness	04-002-0001
39	Signal Harness	04-002-0002
40	Line Filter	04-004-0001
41	Mounting Plate	01-XMP-0029
42	Oil Light Bearing	02-001-0002
43	Plastic Bearing	02-001-0003
44	Pop Rivet 1/8"x1/2"	02-008-0003
45	3/16"x1/4" Screw	02-003-0001
46	#6 Washer	02-006-0001

47	3/16"X3/8" Screw	02-003-0002
48	1/4"X3/8" Screw	02-003-0003
49	10-24 X 1 1/2" Carriage Bolt	02-004-0001
50	3/8" X 1/2" Allen Head Bolt	02-004-0002
51	3/16"X3/4" Sheet Metal Screw	02-003-0003
52	3/16"X3/8" Torque Head	02-003-0004
53	3/8" Roll Pin	02-008-0005
54	3/32"X3/4" Roll Pin	02-008-0006
55	1/8"X1" Roll Pin	02-008-0007
56	1/2"X1 3/4" Roll Pin	02-008-0008
57	1/4" C Ring	02-007-0001
58	1 1/2" Cock Ring	02-007-0002
59	1 1/2" Grip Ring	02-007-0003
60	3/16"X3/8" Washer	02-006-0002
61	Captive Rings	02-007-0004
62	C Ring	02-007-0005
63	10-32 Nut	02-005-0001
64	Hub for 001 Gear	01-Hub-0030
65	C Ring	02-005-0002
66	1/2" Hex Nut	02-005-0003
67	1/2" Flat Washer	02-006-0003
68	Black Washer	02-006-0004
69	Cabinet	03-001-0001
70	Speaker	04-004-0001
71	Speaker Cover	03-004-0001
72	Light Socket	04-004-0002
73	2 SW Clear Light	04-004-0003
74	Banner	03-003-0001
75	Front Bezel	03-003-0002
76	Amber Plex	03-003-0003
77	Fluorescent Light Fixture	04-004-0004
78	Black Light	04-005-0005
79	Fan Motor	04-001-0002
80	Fan Blade	03-002-0001
81	Fan Cover	03-002-0002
82	Monitor Board	03-001-0002
83	Scenery Board	03-004-0002
84	Decal	03-004-0003
85	Footstep	03-001-0003
86	Coin Door	03-002-0003
87	Coin Door Lock	03-002-0004
88	Back Panel Lock	03-002-0005
89	Counter	04-004-0005
90	Coin Box	03-002-0005
91	Transformer Board	03-001-0003
92	1/2" Sheet Metal Screw	02-001-0003
93	Transformer Board	03-001-0003
94	1/2" Sheet Metal Screw	02-003-0005
95	Coin Acceptor	03-002-0006
96	AC Power Cord	04-004-0006
97	Velcro	

ADJUSTMENTS

1. AUDIO VOLUME: The Desert Patrol game utilizes a two channel audio system. Each channel has its own volume control. These two controls are found at the top center of Board 3. You may adjust these two controls for the desired audio volume.

2. TIMER: The pot at the top right on Board 3 is used to set the length of the game. Changing this setting will change the count down rate of the game timer.

3. MACHINE GUN ALIGNMENT:
 - a. Gain access to the calibration panel through the coin door.
 - b. Set the toggle slide switch to the CAL position. This will produce a shot alignment display on the screen.
 - c. There are four pots on this panel. These set the top, bottom, left, and right shot movement boundries. Adjust them as follows:
 1. Move the machine gun against its right stop.
 2. Adjust the right calibration pot so that the CAL display appears at the right edge of the T.V. screen.
 3. Move the machine gun against its left stop.
 4. Adjust the left calibration pot so that the CAL display appears at the left edge of the T.V. screen.
 5. Set the top boundry with the top calibration pot and with the machine gun at the top stop.
 6. Set the bottom boundary and turn off the CAL switch.

4. 50¢ PLAY: The slide switch at the top right of Board 3 is used to select 1 or 2 coin credit. Slide the switch to the left for 1 coin credit or to the right for 2 coin credit.

TABLES AND REFERENCES

PROM 1 ADDRESS MAP

00 - 63	CARGO PLANE	100 POINTS
64 - 127	DC-3 PLANE	200 POINTS
128 - 191	UFO PLANE	300 POINTS
192 - 255	HELICOPTER	400 POINTS
256 - 319	SLOW JET	500 POINTS
320 - 383	SST JET	600 POINTS
384 - 511	EXPLOSION	

PROM 2 ADDRESS MAP

00 - 63	PARACHUTE AND MAN	POSITION 1
64 - 127	PARACHUTE AND MAN	POSITION 2
128 - 191	PARACHUTE AND MAN	POSITION 3
192 - 255	PARACHUTE AND MAN	POSITION 4
256 - 319	FALLING MAN	POSITION 1
320 - 383	FALLING MAN	POSITION 2
384 - 347	FALLING MAN	POSITION 3
348 - 511	FALLING MAN	POSITION 4

32 X 8 PROM DATA		SPEED		LINE +16 16 COMP. 128 256					
IMAGE #	DESCRIPTION	1	2	3	4	5	6	7	8
0	CARGO PLANE	1	1	0	0	1	0	0	0
1	DC-3 PLANE	1	1	0	0	0	0	0	0
2	UFO PLANE	0	0	1	0	1	1	0	0
3	HELICOPTER	1	1	0	0	0	1	0	0
4	FIGHTER JET	1	0	1	0	1	0	1	0
5	SST JET	0	1	1	0	0	0	1	0
6	FIGHTER JET	0	1	1	0	0	0	1	0
7	EXPLOSION	0	0	0	1	0	1	1	0

IMAGE RAM DATA 16 X 16

<u>ADDRESS</u>	RAM BITS															
	1	2	3	4	5	6	7	8	9	10	11	12	13	14	15	16
0	LEVEL 1 BIT ADDRESS								(NOT USED)							
1	LEVEL 2 BIT ADDRESS															
2	LEVEL 3 BIT ADDRESS															
3	LEVEL 4 BIT ADDRESS															
4	LEVEL 1 LINE ADDRESS								P1 IMAGE #		DIRECTION	P1 ENABLE	P2 ENABLE	P2 IMAGE #	IMAGE BLANK	
5	LEVEL 2 LINE ADDRESS															
6	LEVEL 3 LINE ADDRESS															
7	LEVEL 4 LINE ADDRESS															

NOTE: RAM ADDRESSES 8-15 ARE NOT USED FOR DESERT PATROL

EDGE CONNECTOR PIN INDEX

BOARD 1

1.	GROUND	A.	GROUND
2.	+5	B.	+5
3.	BIT ADDRESS 2	C.	BIT ADDRESS 1
4.	+12	D.	+12
5.	BIT ADDRESS 4	E.	BIT ADDRESS 3
6.	BIT ADDRESS 6	F.	BIT ADDRESS 5
7.	BIT ADDRESS 8	H.	BIT ADDRESS 7
8.	-STROBE	J.	ADDRESS BIT START
9.	-STROBE 17	K.	-STROBE 16
10.	-STROBE 19	L.	-STROBE 18
11.	-STROBE 21	M.	-STROBE 20
12.	-STROBE 23	N.	-STROBE 22
13.	-STROBE 25	P.	-STROBE 24
14.	-STROBE 27	R.	-STROBE 26
15.	-STROBE 30	S.	-STROBE 28
16.	-STROBE 31	T.	-STROBE 31
17.	CONDITION 27	U.	DATA BIT 16
18.	DATA BIT 15	V.	DATA BIT 14
19.	DATA BIT 13	W.	DATA BIT 12
20.	DATA BIT 11	X.	DATA BIT 10
21.		Y.	DATA BIT 8
22.	DATA BIT 7	Z.	DATA BIT 6
23.	DATA BIT 5	a.	DATA BIT 4
24.	DATA BIT 3	b.	DATA BIT 2
25.	DATA BIT 1	c.	LINE ADDRESS 1
26.	LINE ADDRESS 2	d.	LINE ADDRESS 3
27.	LINE ADDRESS 4	e.	LINE ADDRESS 5
28.	LINE ADDRESS 6	f.	LINE ADDRESS 7
29.	LINE ADDRESS 8	h.	ADDRESS LINE START
30.	-H DRIVE	j.	READ EXTERNAL ADDRESS
31.		k.	H CLOCK
32.	-V DRIVE	l.	COMPOSITE BLANK
33.	DATA BIT 9	m.	+ H DRIVE
34.	+STROBE A	n.	
35.	+ V DRIVE	p.	CONDITION OUT
36.	CONDITION 8	r.	CONDITION 7
37.	-BIT COMPARE	s.	INHIBIT
38.	V CLOCK	t.	- LINE COMPARE
39.	VIDEO	u.	COMPOSITE SYNC
40.	-12	v.	-12
41.	RAM BIT 12	w.	CONDITION 25
42.	+5	x.	+5
43.	GROUND	y.	GROUND

BOARD 2

1. GROUND
2. +5
3. BIT ADDRESS 2
4. +12
5. BIT ADDRESS 4
6. BIT ADDRESS 6
7. BIT ADDRESS 8
8. RAM BIT 9
9. RAM BIT 10
10. STROBE 19
11. STROBE 21
12. STROBE 23
13. STROBE 25
14. STROBE 27
15. STROBE 30
16. STROBE 31
17. CONDITION 27
18. HIGH SCORE CLEAR
19. -----
20. RAM BIT 16
21. RAM BIT 11
22. DATA BIT 7
23. DATA BIT 5
24. DATA BIT 3
25. DATA BIT 1
26. LINE ADDRESS 2
27. LINE ADDRESS 4
28. LINE ADDRESS 6
29. LINE ADDRESS 8
30. -H DRIVE
31. -----
32. -V DRIVE
33. DATA BIT 9
34. STROBE A
35. +V DRIVE
36. CONDITION 8
37. CONDITION 30
38. SHOT DISABLE
39. VIDEO
40. -12
41. RAM BIT 12
42. +5
43. GROUND

- A. GROUND
- B. +5
- C. BIT ADDRESS 1
- D. +12
- E. BIT ADDRESS 3
- F. BIT ADDRESS 5
- H. BIT ADDRESS 7
- J. ADDRESS BIT START
- K. STROBE 16
- L. STROBE 18
- M. STROBE 20
- N. STROBE 22
- P. STROBE 24
- R. STROBE 26
- S. STROBE 28
- T. CONDITION 0
- U. CONDITION 10
- V. CONDITION 1
- W. -----
- X. DATA BIT 10
- Y. DATA BIT 8
- Z. DATA BIT 6
- a. DATA BIT 4
- b. DATA BIT 2
- c. LINE ADDRESS 1
- d. LINE ADDRESS 3
- e. LINE ADDRESS 5
- f. LIND ADDRESS 7
- h. ADD LINE START
- j. SHOT OUTPUT
- k. H CLOCK
- l. COMPOSITE BLANK
- m. H DRIVE
- n. -----
- p. CONDITION OUT
- r. CONDITION 7
- s. CONDITION 9
- t. CONDITION 6
- u. -----
- v. -12
- w. CONDITION 25
- x. +5
- y. GROUND

BOARD 3

1. GROUND
2. +5
3. BIT ADDRESS 2
4. +12
5. BIT ADDRESS 4
6. BIT ADDRESS 6
7. BIT ADDRESS 8
8. RAM BIT 9
9. RAM BIT 10
10. H LOCATION
11. V LOCATION
12. STROBE 23
13. COIN SWITCH N.C.
14. -----
15. STROBE 30
16. RAM BIT 14
17. CONDITION 27
18. HIGH SCORE CLEAR
19. -----
20. RAM BIT 16
21. RAM BIT 11
22. DATA BIT 7
23. DATA BIT 5
24. DATA BIT 3
25. DATA BIT 1
26. GUN ENABLE
27. LINE ADDRESS 4
28. LINE ADDRESS 6
29. LINE ADDRESS 8
30. -H DRIVE
31. -----
32. -V DRIVE
33. VIBRATION SWITCH
34. CH. 2 AUDIO (A)
35. -----
36. -----
37. CONDITION 30
38. SHOT DISABLE
39. VIDEO
40. -12
41. CH. 1 AUDIO (B)
42. +5
43. GROUND

- A. GROUND
- B. +5
- C. BIT ADDRESS 1
- D. +12
- E. BIT ADDRESS 3
- F. BIT ADDRESS 5
- H. BIT ADDRESS 7
- J. FIRE SWITCH
- K. STROBE 16
- L. CH. 1 AUDIO (A)
- M. -----
- N. COIN SWITCH N.O.
- P. STROBE 24
- R. STROBE 26
- S. STROBE 28
- T. CONDITION 0
- U. CONDITION 10
- V. CONDITION 1
- W. CONDITION 9
- X. START SWITCH
- Y. -----
- Z. DATA BIT 6
- a. DATA BIT 4
- b. DATA BIT 2
- c. LINE ADDRESS 1
- d. LINE ADDRESS 3
- e. LINE ADDRESS 5
- f. LINE ADDRESS 7
- h. SHOT CAL SWITCH
- j. SHOT OUTPUT
- k. CH. 2 AUDIO (B)
- l. COMPOSITE BLANK
- m. +H DRIVE
- n. -----
- p. -----
- r. -----
- s. CONDITION 9
- t. CONDITION 6
- u. -----
- v. -12
- w. CONDITION 25
- x. +5
- y. GROUND

STROBES

0	DISPLAY CONDITIONS AND SEGMENTS
1	LOAD SCORE RAM ADDRESS
2	ADVANCE RAM ADDRESS
3	LOAD SCORE UPDATE COUNTER
4	RESET SCORE UPDATE COUNTER
5	WRITE SCORE RAM
6	ADVANCE SCORE UPDATE COUNTER
7	CARRY CLEAR
8	TRANSFER CARRY
9	ADVANCE UPDATE COUNTER
10	LOAD DOWN COUNTER
11	DECREMENT DOWN COUNTER
12	LOAD P.C. IF D \neq 0
13	LOAD P.C. IF D = 0
14	WRITE REGISTER X
15	JUMP TO REGISTER X
16	LOAD CONDITION
17	
18	WRITE RAM BITS 1-8
19	WRITE RAM BITS 9-16
20	CLEAR SCORE LATCH
21	ADVANCE RAM ADDRESS
22	CLOCK UPDATE F/F
23	LATCH IMAGE #
24	LATCH RAM INPUT BITS 1-8
25	LOAD RAM ADDRESS
26	CLEAR COLLISION ON TRACK # LATCH
27	LOAD DISPLAY RAM
28	TRIGGER TIMER/CLEAR AND SET AUDIO
29	(NOT AVAILABLE)
30	GAME OVER
31	(NOT USABLE)

CONDITIONS

0 COIN IN INITIALIZE
1 CLEAR HIGH SCORE
2 ADD IMAGE 0 SCORE
3 ADD IMAGE 1 SCORE
4 ADD IMAGE 2 SCORE
5 ADD IMAGE 3 SCORE
6 UPDATE TIME
7 A LESS THAN B COMPARE
8 A GREATER THAN B COMPARE
9 -POR
10 + GAME ON
11 END OF TRAVEL
12
13 ADD IMAGE 4 SCORE
14 ADD IMAGE 5 SCORE
15
16 P1 COLLISION ON TRACK 1
17 P1 COLLISION ON TRACK 2
18 P1 COLLISION ON TRACK 3
19 P1 COLLISION ON TRACK 4
20 P2 COLLISION ON TRACK 1
21 P2 COLLISION ON TRACK 2
22 P2 COLLISION ON TRACK 3
23 P2 COLLISION ON TRACK 4
24
25 A=B COMPARE
26 + P1 IMAGE; - P2 IMAGE
27 EXPLOSION TIME
28
29
30 DISPLAY PENALTY
31

SCORE RAM DATA

0	ZERO	
1	10K	PLAYERS SCORE
2	1K	PLAYERS SCORE
3	100'S	PLAYERS SCORE
4	9 (SCORE LT. 1000)	
5		
6		
7		
8		
9		
10	100'S	TIMER
11	10'S	TIMER
12	1'S	TIMER
13	10K	HIGH SCORE
14	1K	HIGH SCORE
15	100'S	HIGH SCORE

A B C D E F H J K L

1 2 3 4 5 6 7 8 9

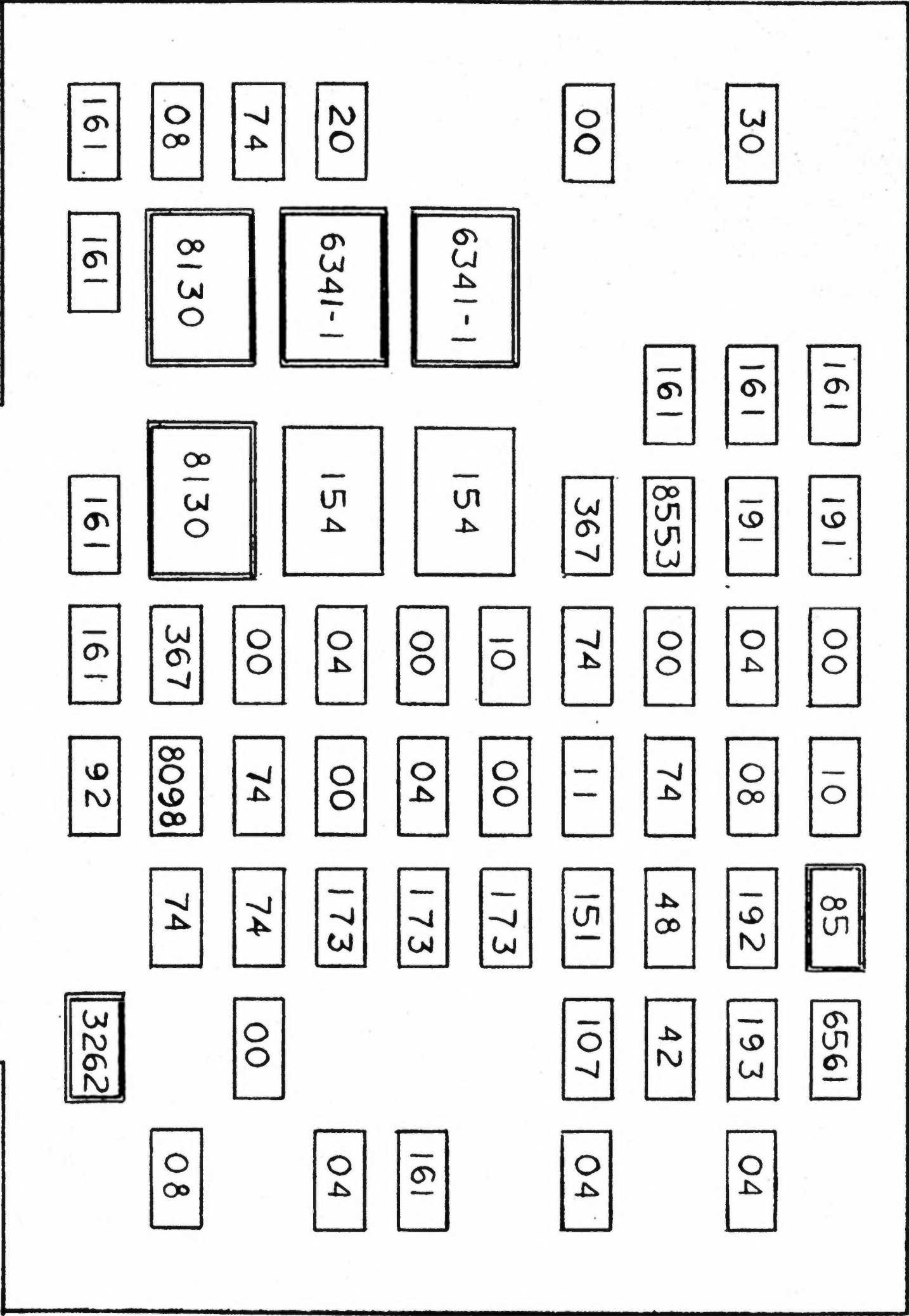

TITLE
DESERT PATROL BOARD 1 LAYOUT

TOP ASSY.

NEXT ASSY.

APPROVED	INT.	DATE
DRAWN	R.C.	7/8/77
CHECKED		
DESIGNER		
PROJ. ENG.		

PROJECT SUPPORT ENGINEERING
 750 NORTH MARY AVENUE
 SUNNYVALE, CALIFORNIA 94086
 PHONE: (408) 739-8550

SH. / OF /	DRAWING NO.
SCALE	REV.

REVISIONS			
ISSUE	DESCRIPTION	DATE	APPROVAL

SYNC GENERATION

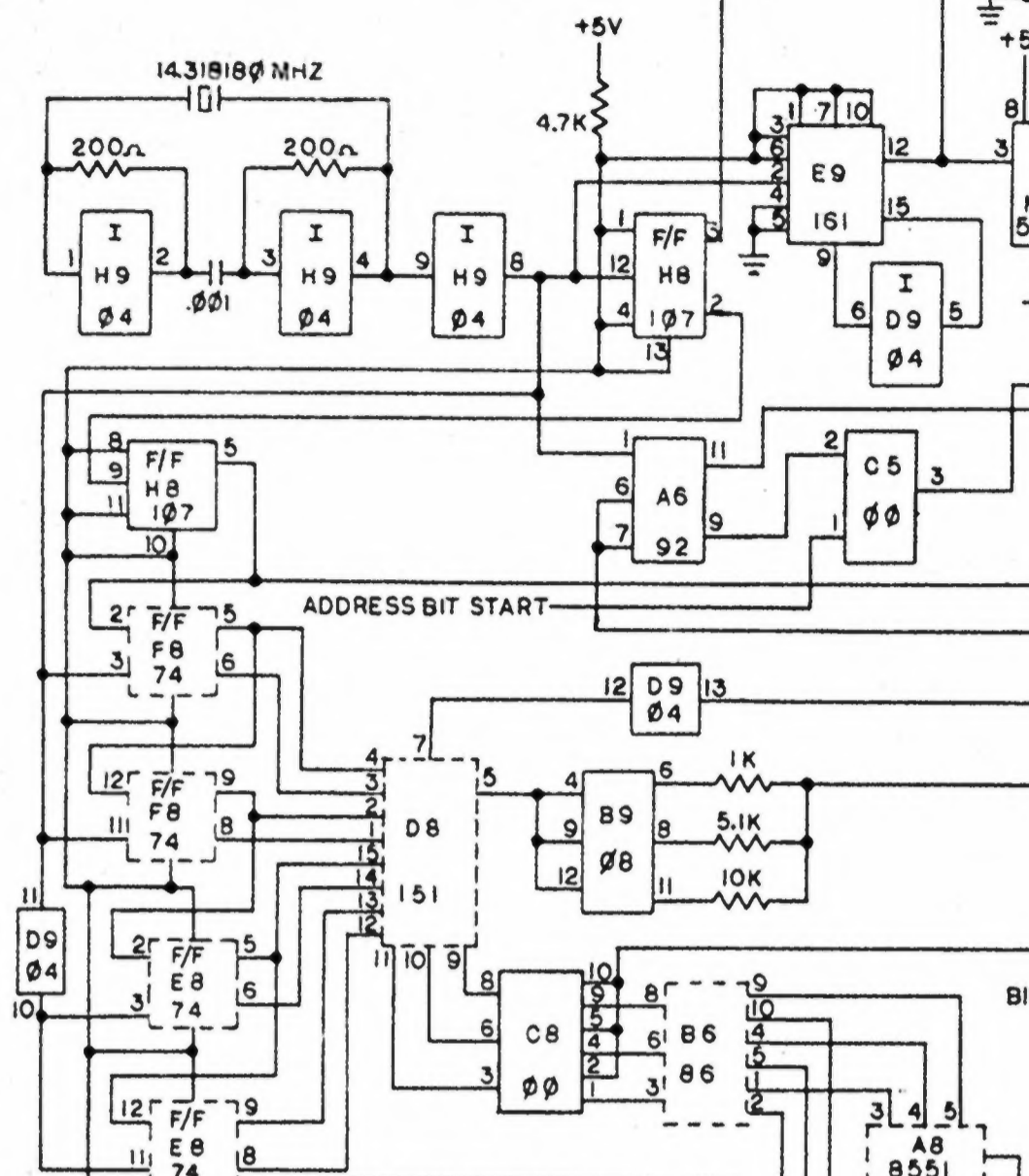
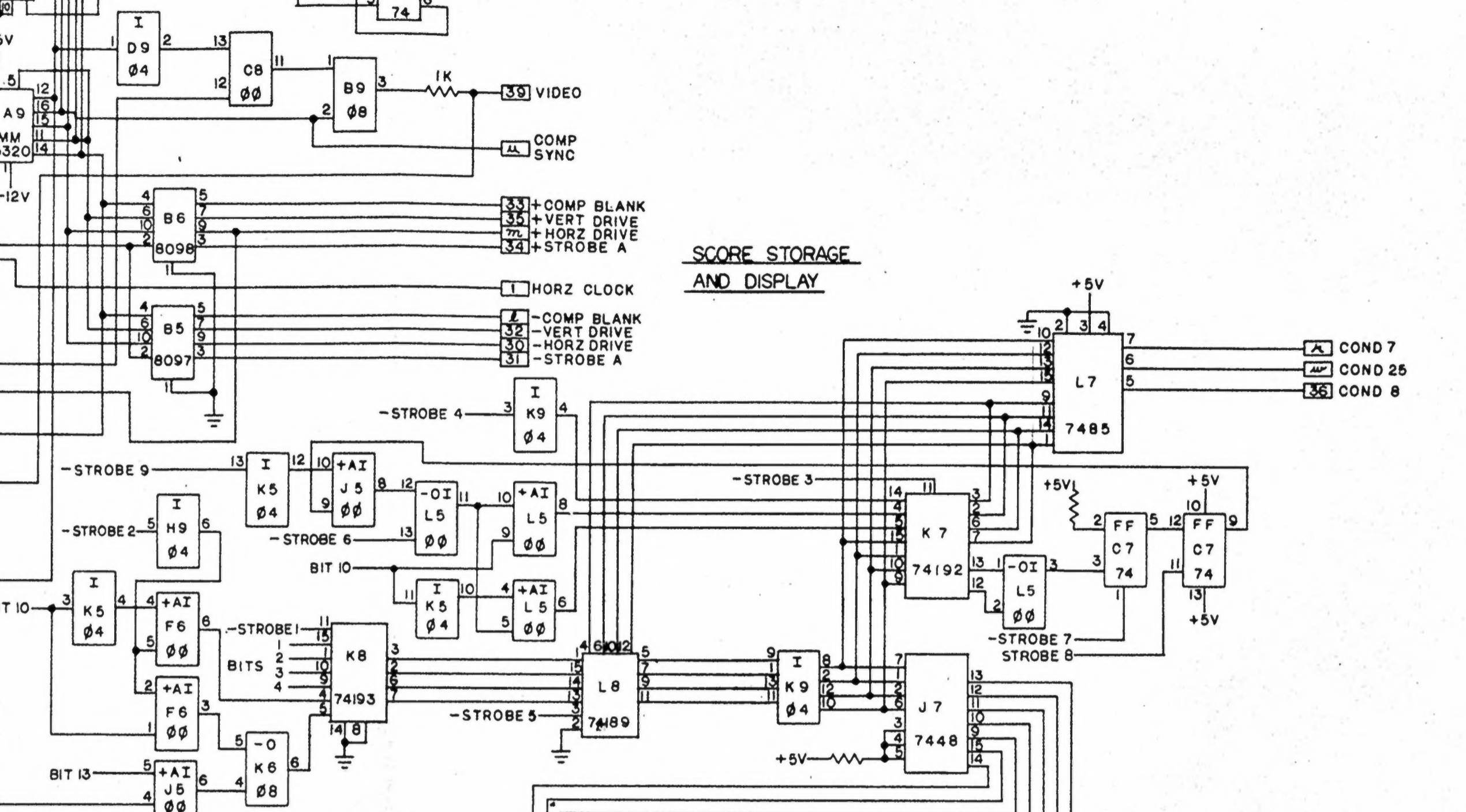

IMAGE CLOCK

INTERLACE

SCORE STORAGE AND DISPLAY



NOTE: COMPONENTS WITH DASHED LINES LOADED ONLY FOR COLOR.

SCORE SEGMENT SELECTION

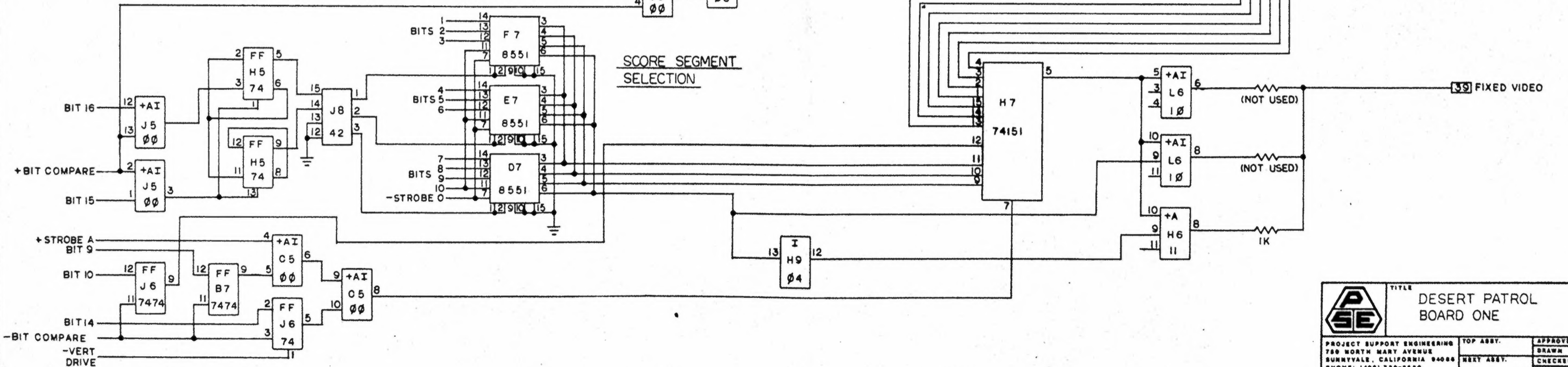

DESERT PATROL BOARD ONE

PROJECT SUPPORT ENGINEERING 780 NORTH MARY AVENUE SUNNYVALE, CALIFORNIA 94086 PHONE: (408) 739-8888	TOP ASBY. NEXT ASBY.	APPROVED INT. DATE DRAWN CHECKED DESIGNED PROJ. ENGR.
DRAWING NO.	SCALE	SH. 1 OF 2

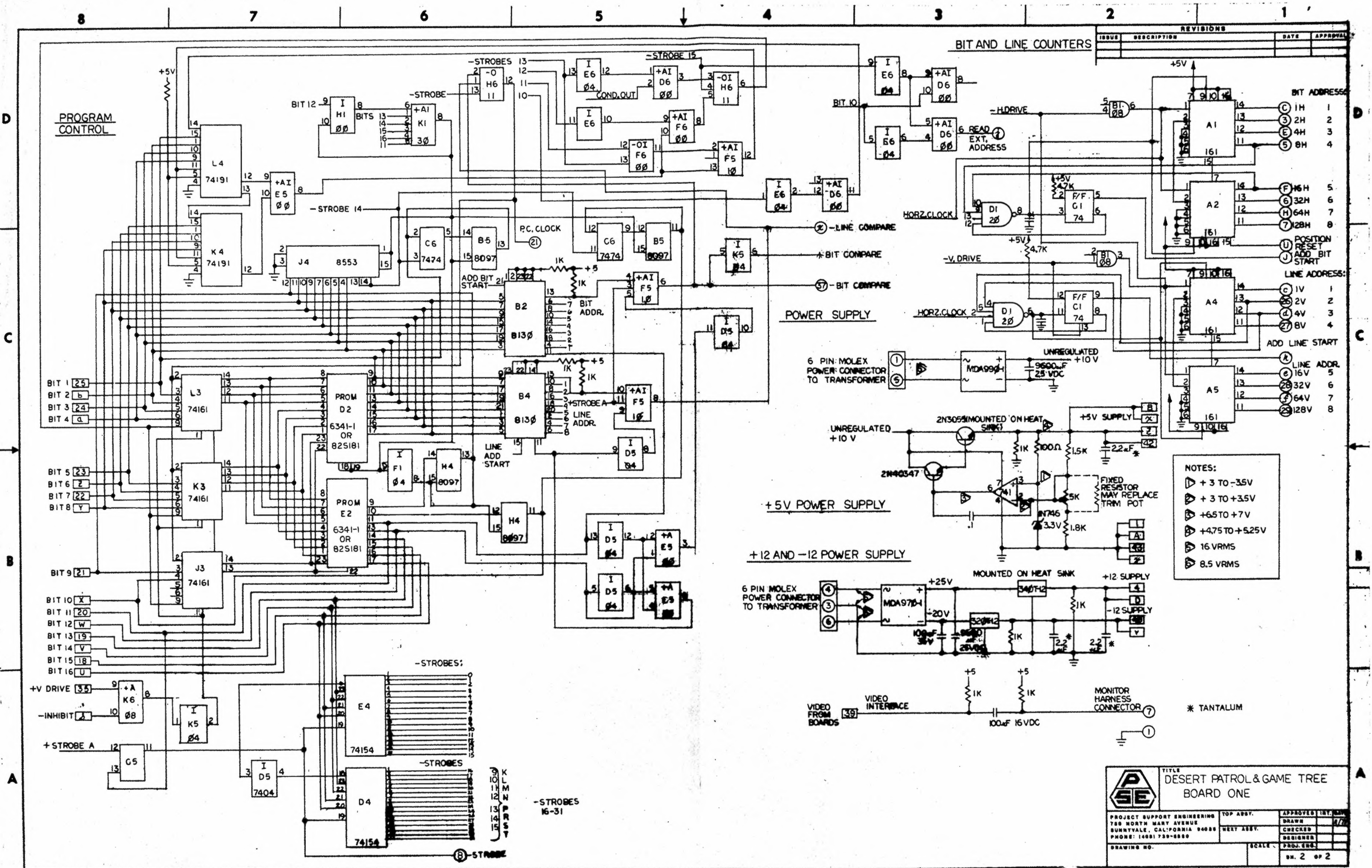

REVISIONS			
ISSUE	DESCRIPTION	DATE	APPROVAL

- NOTES:**
- ▽ +3 TO -3.5V
 - ▽ +3 TO +3.5V
 - ▽ +6.5 TO +7V
 - ▽ +4.75 TO +5.25V
 - ▽ 16 VRMS
 - ▽ 8.5 VRMS

	TITLE DESERT PATROL & GAME TREE BOARD ONE		
	PROJECT SUPPORT ENGINEERING 788 NORTH MARY AVENUE SUNNYVALE, CALIFORNIA 94088 PHONE: (408) 739-8800	TOP ASST. NEXT ASST. DESIGNER PROJ. ENG.	APPROVED (BY, DATE) DRAWN CHECKED SCALE SH. 2 OF 2
	DRAWING NO.		SCALE

REVISIONS			
ISSUE	DESCRIPTION	DATE	APPROVAL

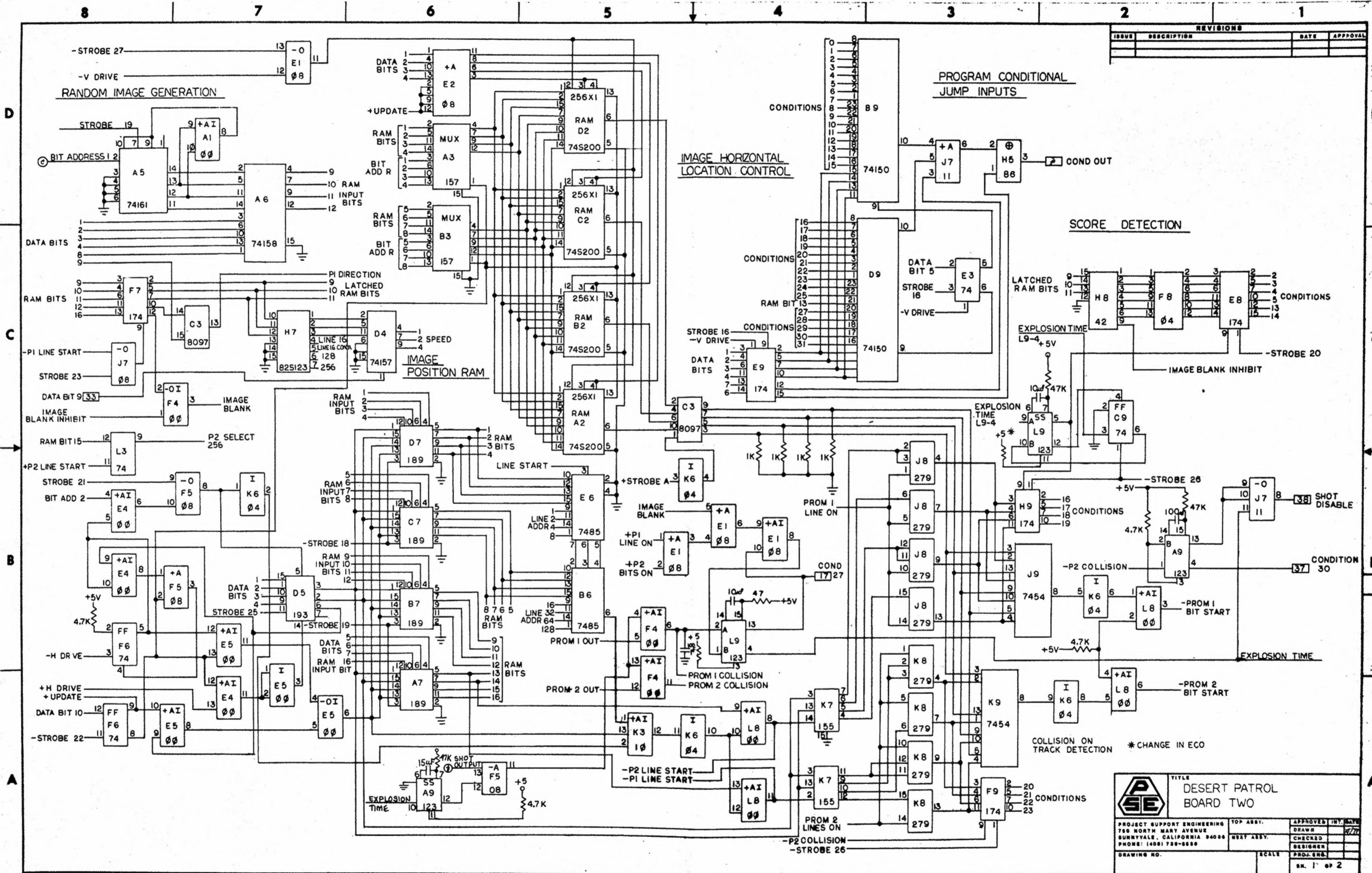

DESERT PATROL BOARD TWO

PROJECT SUPPORT ENGINEERING
780 NORTH MARY AVENUE
SUNNYVALE, CALIFORNIA 94086
PHONE: (408) 730-8800

TOP ASSY. _____
NEXT ASSY. _____
DESIGNER _____
PROJ. ENG. _____

DRAWING NO. _____ SCALE _____
SH. 1' OF 2

REVISIONS			
ISSUE	DESCRIPTION	DATE	APPROVAL

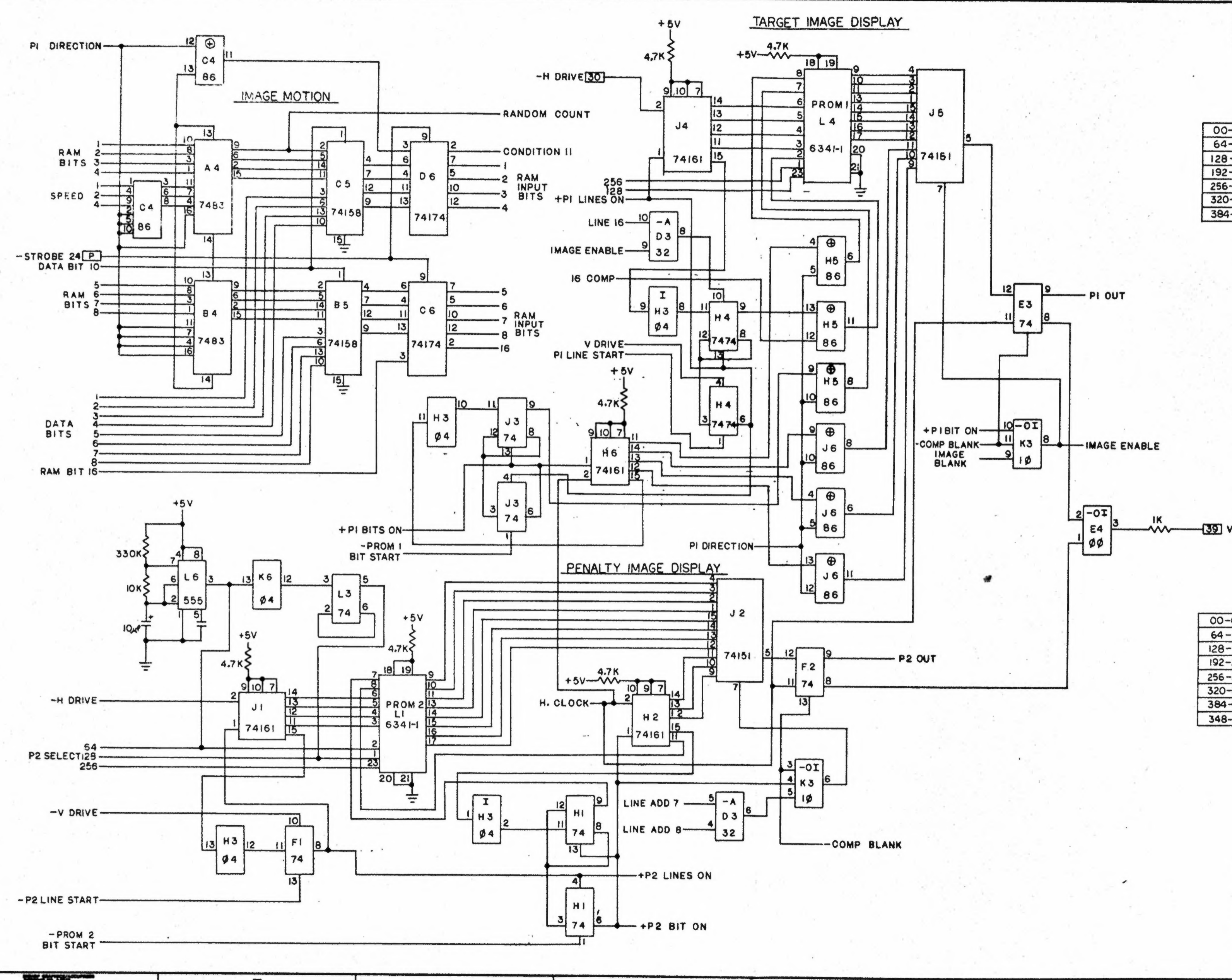

PROM 1 ADDRESS MAP

00-63	CARGO PLANE	100 POINTS
64-127	DC 3 PLANE	200 POINTS
128-191	UFO PLANE	300 POINTS
192-255	HELICOPTER	400 POINTS
256-319	SLOW JET	500 POINTS
320-383	SST JET	600 POINTS
384-511	EXPLOSION	

PROM 2 ADDRESS MAP

00-63	PARACHUTE AND MAN	POSITION 1
64-127	PARACHUTE AND MAN	POSITION 2
128-191	PARACHUTE AND MAN	POSITION 3
192-255	PARACHUTE AND MAN	POSITION 4
256-319	FALLING MAN	POSITION 1
320-383	FALLING MAN	POSITION 2
384-347	FALLING MAN	POSITION 3
348-511	FALLING MAN	POSITION 4

DESERT PATROL BOARD TWO

PROJECT SUPPORT ENGINEERING
750 NORTH MARY AVENUE
SUNNYVALE, CALIFORNIA 94088
PHONE: (408) 739-8880

TOP ASST. []
NEXT ASST. []

APPROVED []
DRAWN []
CHECKER []
DESIGNER []
PROJ. ENG. []

DRAWING NO. [] SCALE []

SH. 2 OF 8

REVISIONS			
NO.	DESCRIPTION	DATE	APPROVAL

COIN IN CONTROL

SHOT GENERATION

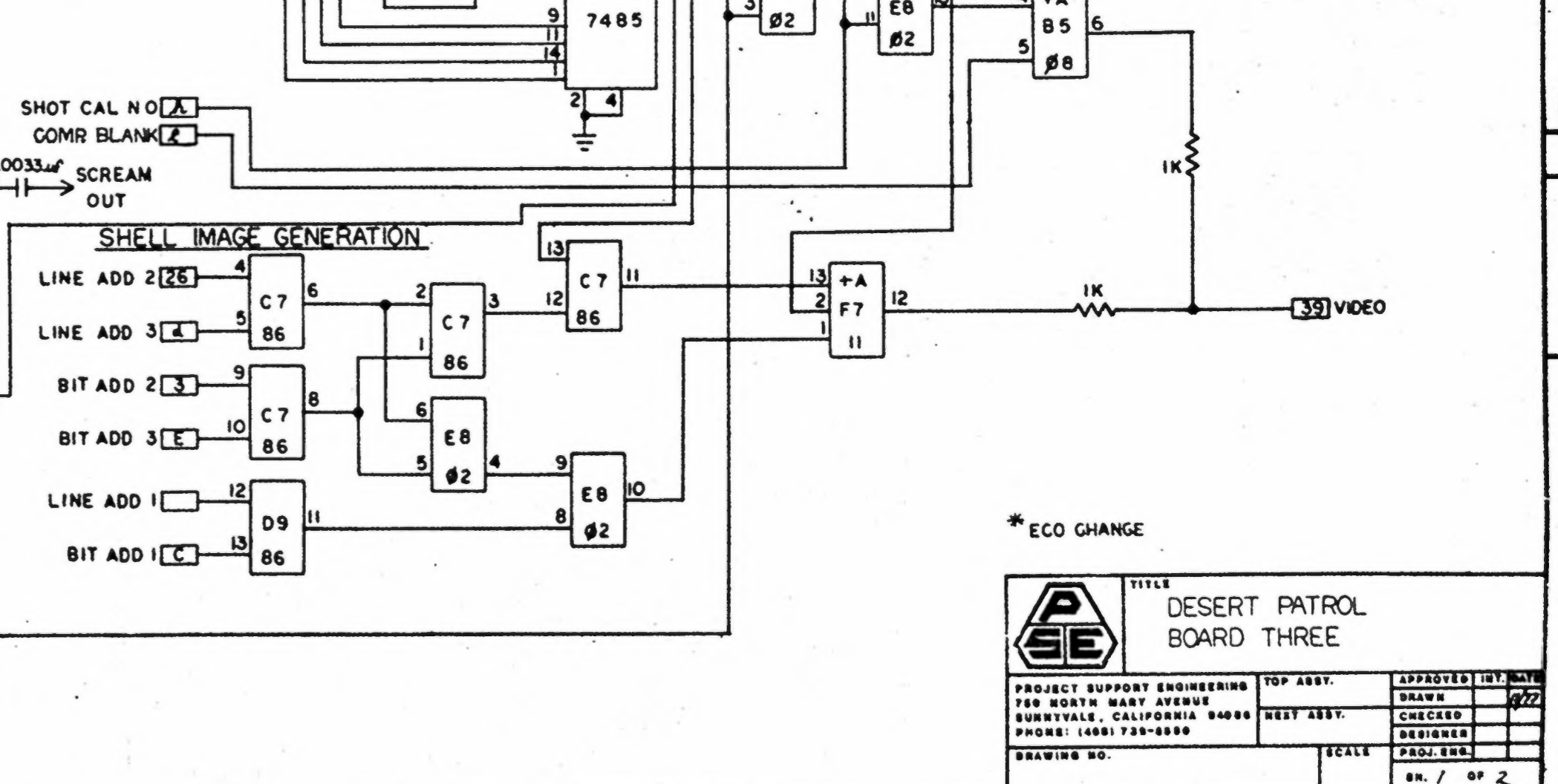
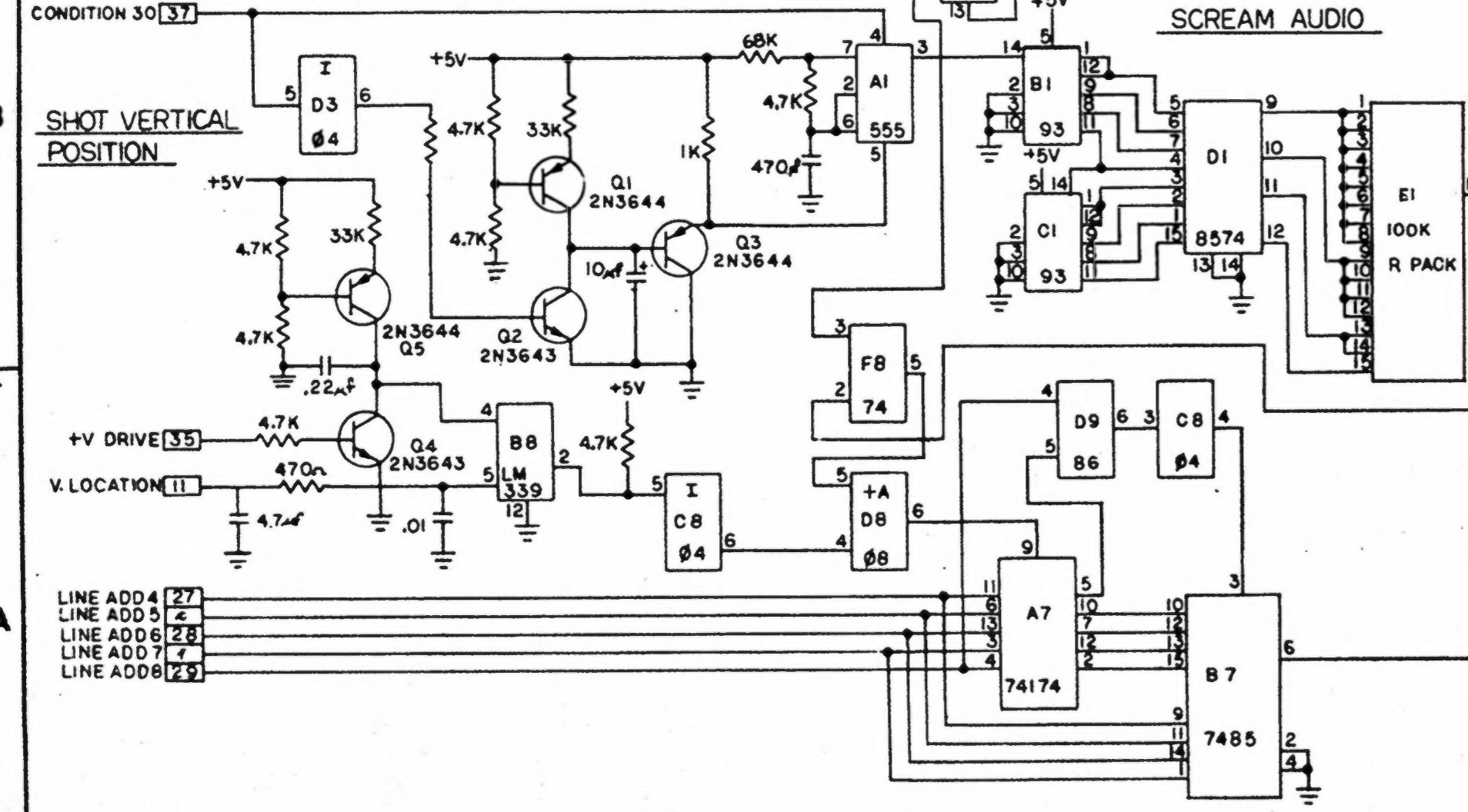
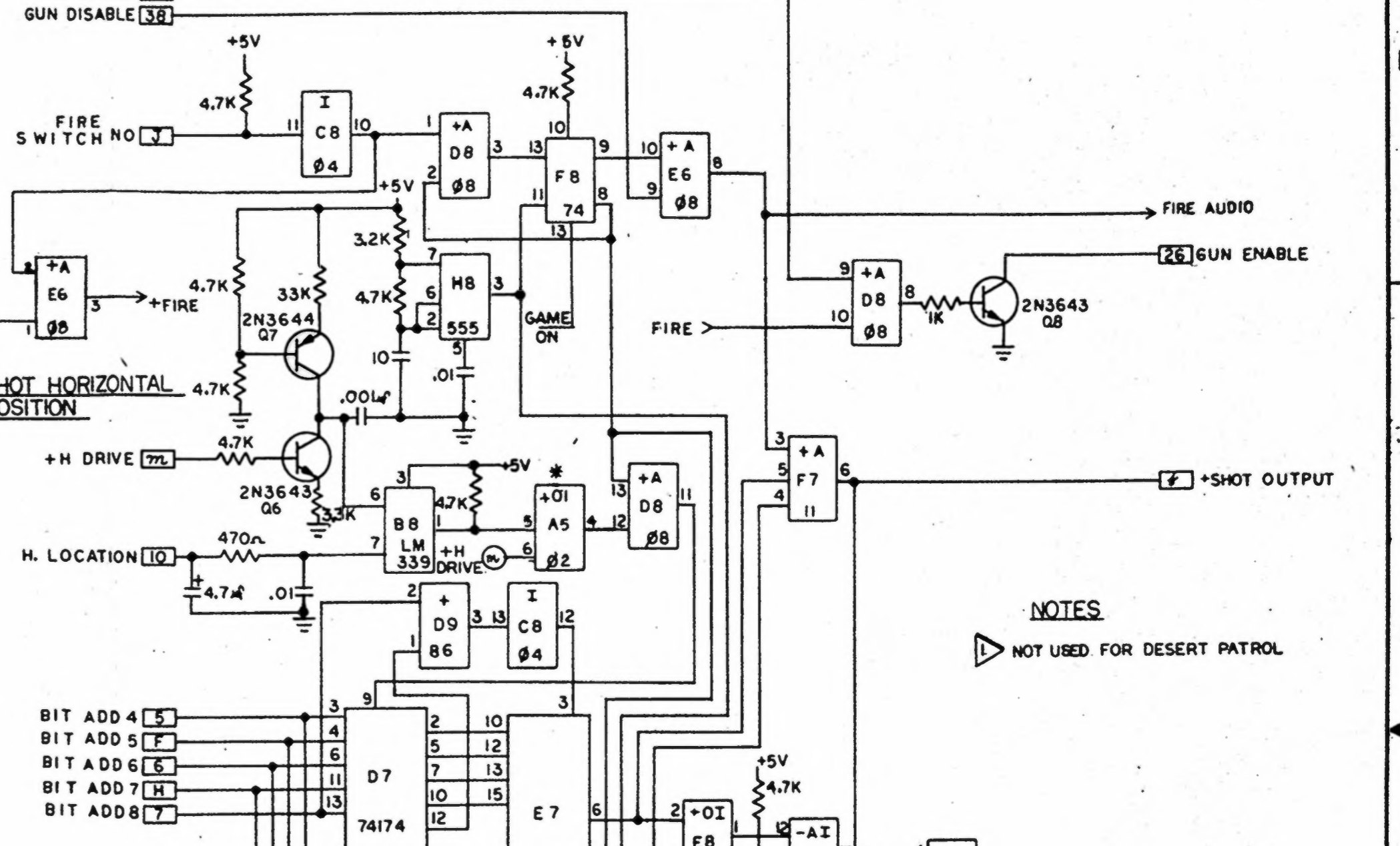
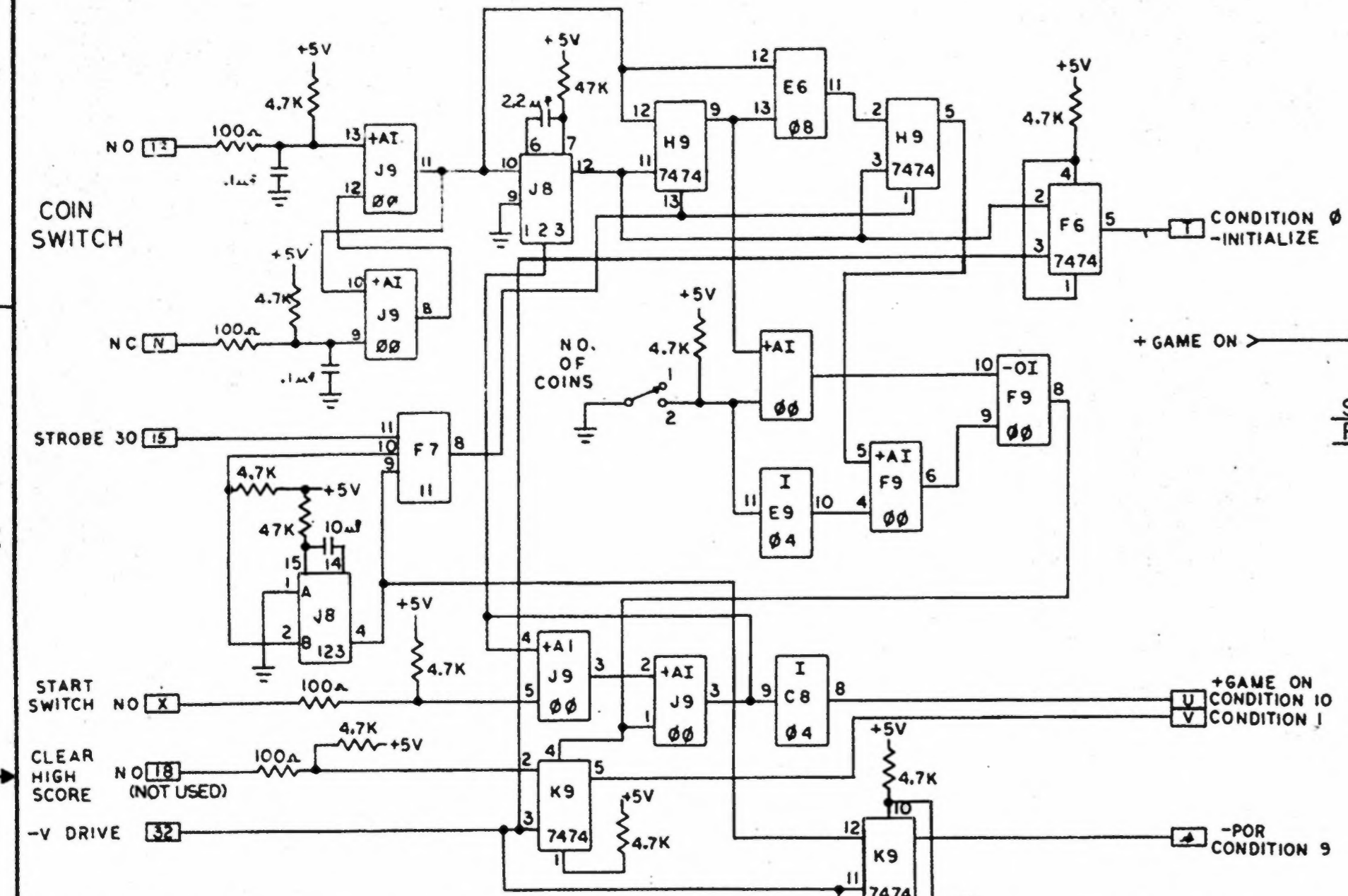

NOTES
 NOT USED FOR DESERT PATROL

* ECO CHANGE

	TITLE DESERT PATROL BOARD THREE	
	PROJECT SUPPORT ENGINEERING 700 NORTH MARY AVENUE SUNNYVALE, CALIFORNIA 94086 PHONE: (408) 739-0000	TOP ASST. BEST ASST.
DRAWING NO.	SCALE	BR. 1 OF 2

REVISIONS			
ISSUE	DESCRIPTION	DATE	APPROVAL

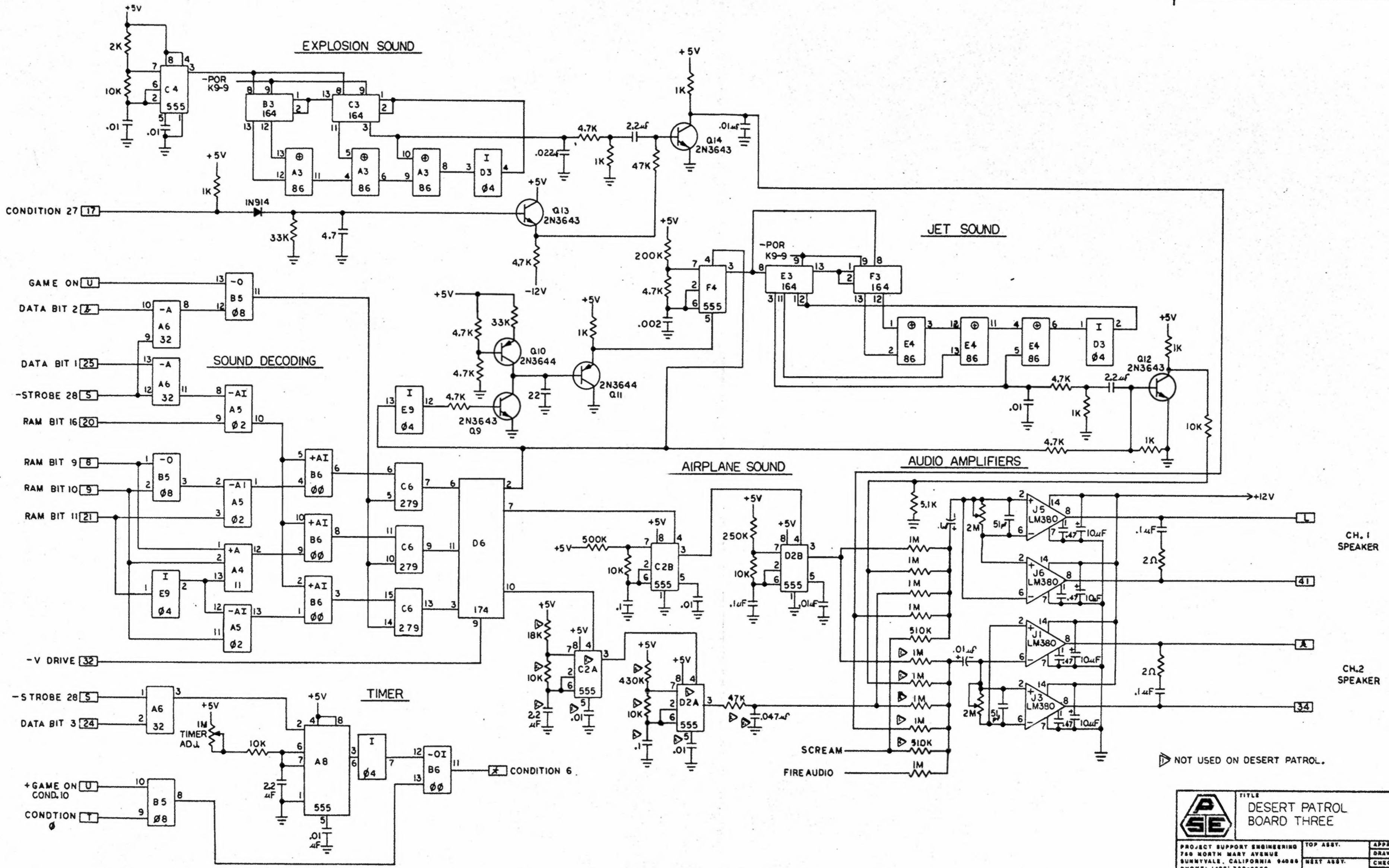

▷ NOT USED ON DESERT PATROL.

	TITLE DESERT PATROL BOARD THREE	
	PROJECT SUPPORT ENGINEERING 760 NORTH MARY AVENUE SUNNYVALE, CALIFORNIA 94086 PHONE: (408) 739-0800	TOP ASST. BEST ASST. SCALE
DRAWING NO.	SH. 2 OF 2	

REVISIONS			
NO.	DESCRIPTION	DATE	APPROVAL

LARGE SIGNAL WIRE: 22AWG					
WIRE NO.	COLOR	STATION	STATION	LENGTH	STRIP
1		P1-1	P4-1	33"	1/8" x 1/8"
2		P1-2	P3-1	36 1/2"	1/8" x 1/8"
3		P1-3	P2-3	30"	1/8" x 1/8"
4		P1-4	P6-	36 1/2"	1/8" x 1/8"
5		P1-5	P4-5	33"	1/8" x 1/8"
6		P1-6	P3-7	36 1/2"	1/8" x 1/8"
7		P1-7	P2-6	30"	1/8" x 1/8"
8		P1-8	P6-	68 1/2"	1/8"
9		P1-9	P5-9	37"	1/8" x 1/8"
10		P1-13	P5-8	37"	1/8" x 1/8"
11		P1-16	P2-6	32"	1/8" x 1/8"
12		P1-17	P6-	68 1/2"	1/8"
13		P1-21	P5-2	37"	1/8" x 1/8"
14		P1-24	P6-	68 1/8"	1/8"
15		P1-25	P4-2	33"	1/8" x 1/8"
16		P1-29	P4-3	33"	1/8" x 1/8"
17		P1-32	P3-9	36 1/2"	1/8" x 1/8"
18		P1-33	P5-2	37 1/2"	1/8" x 1/8"
19		P1-34	P5-3	37 1/2"	1/8" x 1/8"
20		P2-6	P5-5	55"	1/8" x 1/8"
21		P3-1	P1-2	30"	1/8" x 1/8"
22		P3-2	P5-12	30"	1/8" x 1/8"
23		P3-3	P5-7	30"	1/8" x 1/8"
24		P3-6	P5-10	30"	1/8" x 1/8"
SMALL SIGNAL 4732 WIRE: 22 AWG					
WIRE NO.	COLOR	STATION	STATION	LENGTH	STRIP
1		P1-1	STRIP	P3	27 1/4"
2		P1-2	ONE	P3	27 1/4"
3		P1-3	END	P3	27 1/4"
4		P1-4		P3	27 1/4"
5		P1-5		P3	27 1/4"
6		P1-6		P3	27 1/4"
7		P1-7	P2-4	STRIP	22 1/4"
8		P1-8	P2-6	BOTH	22 1/4"
9		P1-10	P2-5	ENDS	22 1/4"
10		P1-11	P2-2	1/8"	22 1/4"
POWER 4733 WIRE: 18AWG					
WIRE NO.	COLOR	STATION	STATION	LENGTH	STRIP
1		P1-1	P5 10	32 1/2"	1/4"
2		P1-2	CABLE		
3		P1-3	CABLE		
4		P1-3	P4	30"	
5		P1-4	P5-9	32 1/2"	
6		P1-6	P5-7	32 1/2"	
7		P1-7	P2-1	7 1/2"	
8		P1-7	P8	48"	
9		P1-8	P2-3	7 1/2"	
10		P1-8	P8	48"	
11		P1-9	CABLE		
12		P3-	P7-2	42"	
13		P3-	P7-1	42"	
14		P3-	P7-3	42"	
15		P5-1	P6-7	39 1/2"	
16		P5-2	P6-1	30"	
17		P6-12	P5-12	29 1/2"	
18		P8-	P9-	73"	
19		P8-	P9-	73"	

<ADD P1-28 P5-4 37" 1/8" x 1/8"

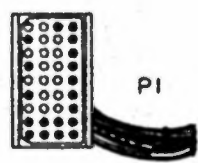

P1



P2



P2



P1

(2 OF 10)



P3

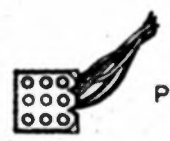

P3



P4

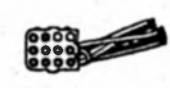

P5



P6

	TITLE DESERT PATROL & GAME TREE WIRING HARNESS	
	PROJECT SUPPORT ENGINEERING 750 SOUTH MAIN AVENUE BURNHELM, CALIFORNIA 92609 PHONE: (609) 730-0000	TOP ASST. DESIGNED CHECKED DRAWN DATE
DRAWING NO.	SCALE 1/1	SHEET NO. 1 OF 1

Desert Patrol

FOR SERVICE, CALL OR WRITE:

Project Support Engineering.

750 N. Mary Avenue
Sunnyvale, CA 94086
Telephone (408) 739-8550
Toll Free (800) 538-1798
Telex 346-415



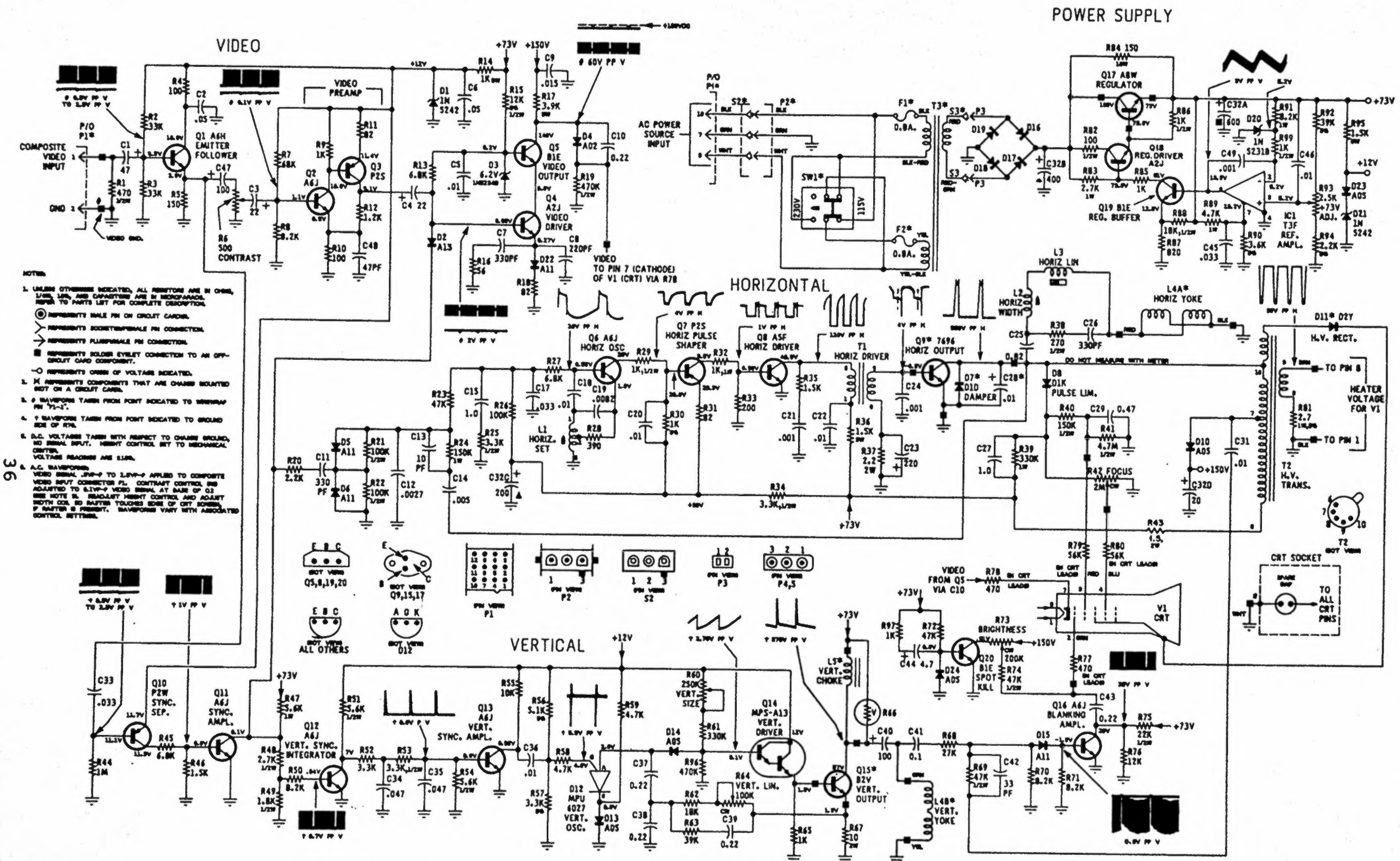

- NOTES:
- UNLESS OTHERWISE INDICATED, ALL RESISTORS ARE IN OHMS, 1/4W, 5% AND CAPACITORS ARE IN MICROFARADS. REFER TO PARTS LIST FOR COMPLETE DESCRIPTION.
 - REPRESENTS MALE PIN ON CIRCUIT BOARD.
 - REPRESENTS SOCKET/FEMALE PIN CONNECTION.
 - REPRESENTS PLUMBLINE PIN CONNECTION.
 - REPRESENTS SOLDER CRYSTAL CONNECTION TO AN OFF-CIRCUIT BOARD COMPONENT.
 - REPRESENTS OPEN OF VOLTAGE INDICATED.
 - X REPRESENTS COMPONENTS THAT ARE CHASSIS MOUNTED NOT ON A CIRCUIT BOARD.
 - F WAVEFORM TAKEN FROM POINT INDICATED TO WINDING PIN "1-2".
 - T WAVEFORM TAKEN FROM POINT INDICATED TO GROUND SIDE OF RTN.
 - D.C. VOLTAGE TAKEN WITH RESPECT TO CHASSIS GROUND, NO SIGNAL INPUT. HEIGHT CONTROL SET TO MECHANICAL CENTER. VOLTAGE READINGS ARE 1.16A.
 - A.C. WAVEFORMS: VIDEO SIGNAL - 1VP-P TO 2VP-P APPLIED TO COMPOSITE VIDEO INPUT CONNECTOR PL. CONTRAST CONTROL IS ADJUSTED TO 5VP-P VIDEO SIGNAL AT BASE OF Q1. SEE NOTE IN BRIGHTNESS HEIGHT CONTROL AND ADJUST BOTH CTR. NO BATTERY TOUCHES EDGE OF CRT BOARD. BATTERY IS PRESENT. WAVEFORMS VARY WITH ASSOCIATED CONTROL SETTINGS.

36

M5000-155, M7000-155 - Diagram Schematic



PROJECT SUPPORT ENGINEERING
750 N. Mary Ave., Sunnyvale, CA 94086

TERMS AND CONDITIONS OF WARRANTY

1. PURCHASER'S INSPECTION AND ACCEPTANCE OF GOODS

Purchaser shall properly inspect and test the goods sold hereunder immediately upon their arrival and shall within ten days after their arrival give written notice to Project Support Engineering (PSE) of any claim that the goods are damaged or defective. If Purchaser fails to inspect and test the goods as called for above, Purchaser will be held to have accepted the goods with all faults that inspection and testing would have revealed, to have waived all rights Purchaser may have had to revoke acceptance after said ten day period, and to have waived all claims for breach of warranty arising out of or occasioned by any such faults.

2. LIMITED WARRANTY

PSE warrants the printed circuit board contained in the Video Game to be free from defects in workmanship and materials for a period of one year from the date of shipment provided warranty registration procedures are complied with. EXCEPT AS PROVIDED IN THE PREVIOUS SENTENCE, PSE MAKES NO WARRANTY, EXPRESS OR IMPLIED, OF MERCHANTABILITY OR FITNESS FOR A PARTICULAR PURPOSE, AND NO OTHER WARRANTIES EXPRESS OR IMPLIED, ARE MADE HEREIN UNLESS SPECIFICALLY PROVIDED FOR BY WRITTEN ATTACHMENT HERETO. The printed circuit boards warranted herein shall not be returned to PSE without prior approval of PSE. Defective printed circuit boards should be shipped after approval of PSE to PSE's Home Office for repair or replacement. Purchaser shall be responsible for all cost of shipment and risk of loss or damage during shipment.

3. EXCLUSIVE REMEDIES AND LIMITATION OF LIABILITY

With respect to claims based on alleged damaged or defective goods or alleged negligence of PSE, BUYERS EXCLUSIVE REMEDY SHALL BE FOR DAMAGES. THE LIABILITY OF PSE FOR ANY LOSS OR DAMAGE CAUSED BY DAMAGED OR DEFECTIVE GOODS, IRRESPECTIVE OF WHETHER SUCH DEFECTS ARE DISCOVERABLE OR LATENT, OR FOR THE NEGLIGENCE OF PSE, SHALL IN NO EVENT EXCEED THE PURCHASE PRICE OF THE PARTICULAR GOODS CAUSING LOSS OR DAMAGE, OR, AT THE ELECTION OF PSE, THE REPAIR OR REPLACEMENT OF EQUIPMENT OR PARTS COVERED BY THE WARRANTY, such repair or replacement to occur at the location selected by PSE IN NO EVENT SHALL PSE BE LIABLE FOR INCIDENTAL OR CONSEQUENTIAL DAMAGES CAUSED BY DAMAGED OR DEFECTIVE GOODS OR THE NEGLIGENCE OF PSE.

Detach and Mail to PSE

WARRANTY REGISTRATION CARD

COMPANY NAME: _____

ADDRESS: _____

CITY, STATE, ZIP: _____

SERIAL NO: _____ DATE OF SHIPMENT: _____

PURCHASED FROM: _____

ADDRESS: _____

CITY, STATE, ZIP: _____

BUSINESS REPLY MAIL

No postage necessary if mailed in the United States
Postage will be paid by:



PROJECT SUPPORT ENGINEERING

750 N. MARY, SUNNYVALE, CALIFORNIA 94086

First Class
Permit No. 875
Sunnyvale CA

