

★ **DESTRUCTION** ★ **DERBY** ★



**EXIDY**  
**SERVICE**  
**MANUAL**

## TABLE OF CONTENTS

	PAGE NO.
I. GENERAL INFORMATION	1
II. OBJECT OF THE GAME	1
III. NORMAL OPERATION	1
IV. SYSTEM FUNCTIONAL DESCRIPTION	2
Power Supply	
Logic Printed Circuit Board (PCB)	
Coin Mechanism	
Start Switch	
Steering Units	
Pedal Units	
Speakers	
T.V. Monitor	
Shift Lever	
V. TROUBLESHOOTING TIPS	2
Picture not present	
Entire picture scrambled	
Picture present but partially bad or characters act incorrectly	3
Bad Steering	
No shift	
No acceleration or bad acceleration	
No game start/sound present	
No game start/sound not present	
Game starts/no sound	
VI. ADJUSTMENTS	
Power Supply Adjustment	4
Volume Adjustment	
Tone Adjustment	
Game Time Adjustments	
VII. FIGURES	5
Figure 1	6-7
Figure 2	8-9
Figure 3	11
Figure 4	13
Figure 5	15
Figure 6	16
Figure 7	19
Figure 8	20-21
Figure 9	23

# DESTRUCTION DERBY

## I. GENERAL INFORMATION:

DESTRUCTION DERBY pits the player against an intelligent acting robot car (or drone). Unlike most "player versus machine" games, the "machine" in this case does not simply repeat an action or sequence, but actually "sees", "thinks", and "acts" as intelligently (and even more rapidly) than would another player. The result of this is that each game is a new and different experience.

## II. OBJECT OF THE GAME:

The object of the game is simple. Crash into a drone car; and you win a point.

There are two drone cars driving by themselves around the playing field in a random fashion. They are intelligent robots in every sense and will avoid all objects so long as they can see a way to escape.

You drive one of two cars which are completely under your control. You can steer them anywhere in any direction within the playing field; move forward in low or high gear; and move in reverse when necessary. You can drive as fast, but no faster, than the drones.

When you crash into a drone, it will break apart (simulating a wreck) and remain in that same spot until the game is over and a new game begun. Wherever you crash into the drone on the playing field, the wreckage will remain. Thus, each game creates its own totally random and different maze of wreckage that each player must steer through while chasing the drones. The more crashes, the more wreckage; the more wreckage, the harder the steering becomes. Thus, it becomes increasingly difficult to maneuver as your skill increases.

## III. NORMAL OPERATION:

The screen is divided horizontally into three (3) areas: the larger being in the middle between the dotted lines. This represents the legitimate playing field. It is only in this area that crashes can occur; and any driven (player) car that attempts to leave this area will crash when it contacts the top, bottom, or (dotted) side lines. There is no point given or wreckage created for this type of crash.

Although the driven cars will crash when trying to cross the dotted line toward the solid side-line, the drones can and do pass through without crashing.

The areas on the sides between the solid and dotted lines are a designated "safe" area for the drones. They will enter this area at will.

When you crash your car into anything, whether it be a drone, wreckage from a previous crash, or a boundary (line), your car will pause briefly before moving again, unless you immediately shift into reverse to back away from the scene of the crash. Even if you do not back away, your car will begin to move again. It is thus possible to crash into and pass through, after a pause, any boundary. Although by this method you can leave the playing field and pass into the safe zone or other "out of bounds" areas, you cannot intercept and wreck a drone nor receive a point outside the playing field.

Once outside the playing field, you may drive your car off the visible screen and it will reappear on the opposite side of the screen. The drones can do this also but should only do so if the safe zone area is blocked and there is no place for them to enter the playing field. In this case, they will normally drive off the screen to the side and reappear on the opposite side. A drone should never pass through the top or bottom boundaries.

Should one player crash into the other player, both cars will pause briefly then proceed without wreckage. Because of this, it is sometimes advantageous to crash into your opponent's car in order to slow down and prevent your opponent from wrecking a drone and scoring. There is no score from crashing into your opponent's driven car.

When one coin is inserted the sound for player one is enabled. When a second coin is inserted, the sound for player two is enabled. When the start button is depressed the game begins, the players can drive their cars and the game counter counts down from 99 toward 00. The duration of the game is adjustable in three (3) increments from one (1) minute twenty (20) seconds, to two (2) minutes fifteen (15) seconds. See "ADJUSTMENTS" for information regarding game time.

Each driven car has two forward speeds. When the pedal is not depressed, the car will not move, but will turn on its axis as the steering wheel is turned. Slight depressing moves the car forward in low gear, and full depression moves the car forward in high gear. If the shift lever is in reverse, the car will move backwards at a low gear speed. There is no high gear in reverse.

#### IV. SYSTEM FUNCTIONAL DESCRIPTION (Refer to System Block Diagram, Fig. 7)

115 VAC power is applied through interlock switch S1 (back door panel) to the power supply, the T.V. monitor, and the light fixtures.

The Power Supply converts this to +5VDC and 22 VAC. The +5VDC is used to power the LOGIC PCB (printed circuit board), Coin Counter, both steering units (optical boards), and both foot pedal units (2 microswitches each), the 22 VAC is used to power the audio (sound circuitry located on the LOGIC PCB.

The Logic PCB generates all video (T.V. picture), audio (sound), and is the nerve center for all control functions.

The Coin Mechanism signals the Logic PCB that a one (1) or two (2) player game can now begin, pending the pressing of the start switch. It also simultaneously signals the coin counter to advance one (1) count for each coin.

The Start Switch, when depressed, signals the logic PCB that a game can now begin.

The Steering Units for player 1 and player 2 are identical, and each consists of a steering wheel, a shift lever, and an optical control board. The optical control board converts the rotation of the steering wheel and the two (2) positions of the shift lever (forward & reverse) into commands which are routed to the Logic PCB, which then interprets and executes these commands, causing the driven cars on screen to react accordingly.

The Pedal Units for player 1 and player 2 are identical and each consists of a spring loaded foot pedal and two (2) microswitches. The pedal, when in the "off" position (not depressed) trips the top microswitch and does not trip the bottom switch. Depressing the pedal down slightly allows both the top and bottom microswitch to be in an "untripped" state, which tells the Logic PCB that the corresponding player is now in low gear. Further depression of the pedal trips the bottom microswitch, telling the Logic PCB that the corresponding player is now in high gear. The image on screen will then react accordingly.

The Speakers, which are located in the steering module, receive their signal directly from the Logic PCB; and are not activated until the coin mechanism has been tripped by a coin. They will remain active only while a game is in progress. When the game ends, so does the sound.

The Shift Lever is part of the steering units, and its signal is developed by the same optical control board as is the steering (see steering units).

#### V. TROUBLESHOOTING TIPS

##### NOTE

The single most important factor in the proper operation of your Destruction Derby game is the power supply voltage adjustment. Before any troubleshooting can be done the power supply voltage must be checked, and adjusted if necessary. See "POWER SUPPLY ADJUSTMENT".

##### PICTURE NOT PRESENT

Check:

1. 115 VAC system power
2. +5VDC power supply
3. All harnesses connected
4. T.V. brightness control

##### ENTIRE PICTURE SCRAMBLED

Check:

1. T.V. horizontal hold control
2. T.V. vertical hold control
3. +5VDC power supply adjusted

**PICTURE PRESENT BUT PARTIALLY BAD, OR CHARACTERS ACT INCORRECTLY.**

Check:

1. +5VDC power supply adjusted
2. Nothing external touching Logic PCB
3. Harnesses all tightly connected

**NO STEERING OR BAD STEERING:**

Check:

1. Light bulbs on optical control boards
2. +5VDC power supply
3. Optical board harness connected
4. Light bulbs on optical control boards aligned properly (See Fig. 5)

**NOTE**

If only one player has bad steering the optical board can be tested by plugging the player 1 connector to the player 2 optical board (and vice versa). If this method is used be extremely careful to insure the connector is not plugged in backward. Plugging the connector in backward will destroy the optical board.

**NO SHIFT**

Check:

All checks are the same as those listed under "NO STEERING OR BAD STEERING" above.

**NO ACCELERATION OR BAD ACCELERATION**

Check:

1. Foot pedals free to operate
2. Micro switches on foot pedals
3. Foot pedal harness connected
4. +5VDC power supply

**NOTE**

If only one player has bad acceleration the foot pedal harnesses can be reversed for checkout of microswitches if necessary, as outlined for steering problems under "NO STEERING OR BAD STEERING" above.

**NO GAME START/SOUND PRESENT**

Check:

1. Start switch
2. +5VDC power supply
3. Start switch harness connected

**NO GAME START/SOUND NOT PRESENT**

Check:

1. Coin Mechanism — NOTE: Coin mechanism functions okay if drop of coin causes cars to reset to start position at bottom of screen, facing upwards.
2. +5VDC power supply
3. Harnesses connected

**GAME STARTS/NO SOUND**

Check:

1. 22 VAC from power supply
2. Speaker harnesses connected

Any problems which cannot be localized to other units probably indicate a bad LOGIC PCB, since it is the heart of the system. If another is available it should be temporarily placed in the bad game to see if the problem remains.

## VI. ADJUSTMENTS

### POWER SUPPLY ADJUSTMENT

1. Contact voltmeter leads to Logic PCB as indicated in Fig. 6.
2. Adjust potentiometer R8 (see fig. 4) on power supply for +5.0 VDC as measured on the LOGIC PCB per above diagram. The positive (+) lead of the voltmeter must be touching the large metal area (trace) on the non-component side of the Logic PCB which is connected to pins 2 and 5 of the 6 pin connector. The negative (-) lead of the voltmeter must be touching the large metal area (trace) on the component side of the LOGIC PCB, which is connected to pins 1 and 6 of the 6 pin connector.

### NOTE

This voltage measurement must be made at the LOGIC PCB, since voltage losses may occur between the power supply and the Logic PCB. Adjustment of the power supply voltage made while measuring the voltage directly on the power supply terminals will not necessarily insure proper voltage to be present on the Logic PCB.

### VOLUME ADJUSTMENTS (Refer to fig. 6)

Volume controls are located on the Logic PCB and are as follows:

- |                     |     |
|---------------------|-----|
| 1. Player one motor | R50 |
| 2. Player two motor | R66 |
| 3. Player one crash | R80 |
| 4. Player two crash | R70 |

### TONE ADJUSTMENTS (Refer to Fig. 6)

Tone controls are located on the Logic PCB and are as follows:

- |               |     |
|---------------|-----|
| 1. Player one | R7  |
| 2. Player two | R14 |

### GAME TIME ADJUSTMENTS (Refer to Fig. 6)

A movable jumper wire, located on the LOGIC PCB, allows adjustment of the length of game time. The counter will always begin at 99 and begin to count down to 00 when the START button is depressed after a coin is inserted. The rate at which the counter counts down will vary depending on the location of the jumper wire. Three options are available for a short, medium, and long game time. These are selected by placing the jumper wire on the appropriate terminal post. The post nomenclatures and approximate times are listed below:

- Post Y = 1 minute 20 seconds  
Post Z = 1 minute 45 seconds  
Post X = 2 minutes 15 seconds

## FIGURES

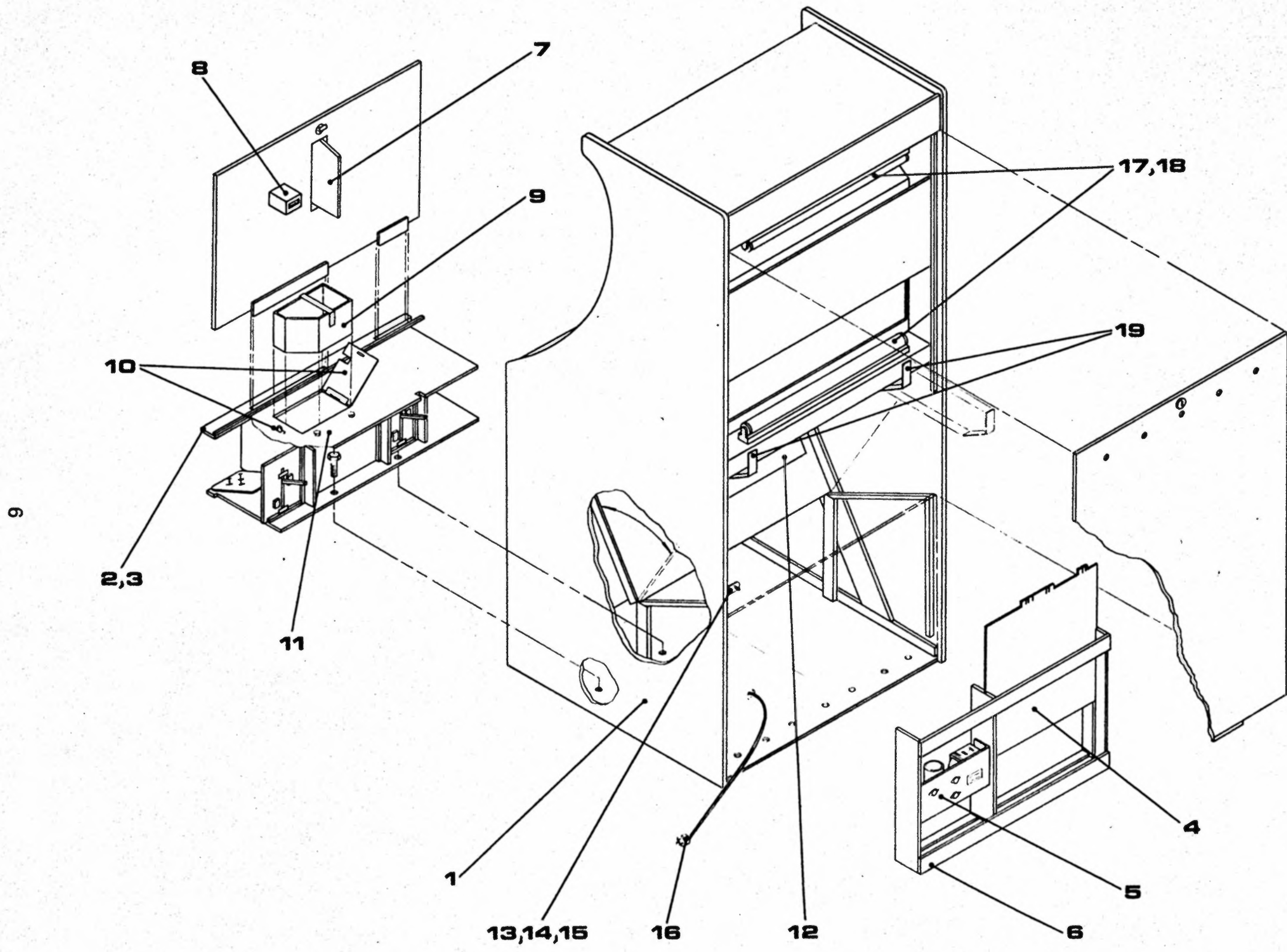

FIG 1

Figure No. 1

**EXIDY**

<b>ITEM</b>	<b>PART NO.</b>	<b>DESCRIPTION</b>
1.	DD-UP-CAB	Cabinet
2.	DD-FP-BOX-COMPLETE	Foot pedal box comp
3.	DD-FP-BOX-EMPTY	Foot pedal box empty
4.	PD-PCB-6	Game printed circuit board
5.	EAPS-5-10	Power supply
6.	DD-PCB-PS-B	Power supply & P.C.B. box
7.	2608-300	Coin mech
8.	E607	Coin counter
9.	DD-CB	Coin bucket
10.	DD-CB-LH	Coin box lid & hasp
11.	DD-FP-C	Foot pedal box cover
12.	XM701-10	Monitor
13.	E64-30A	Interlock switch
14.		Fuse holder
15.		Fuse
16.	17412	AC cord
17.	F20T12CW	Fluorescent bulb
18.	S120TS	Fluorescent fixture
19.	DD-MON-BRK7	Monitor brkt.

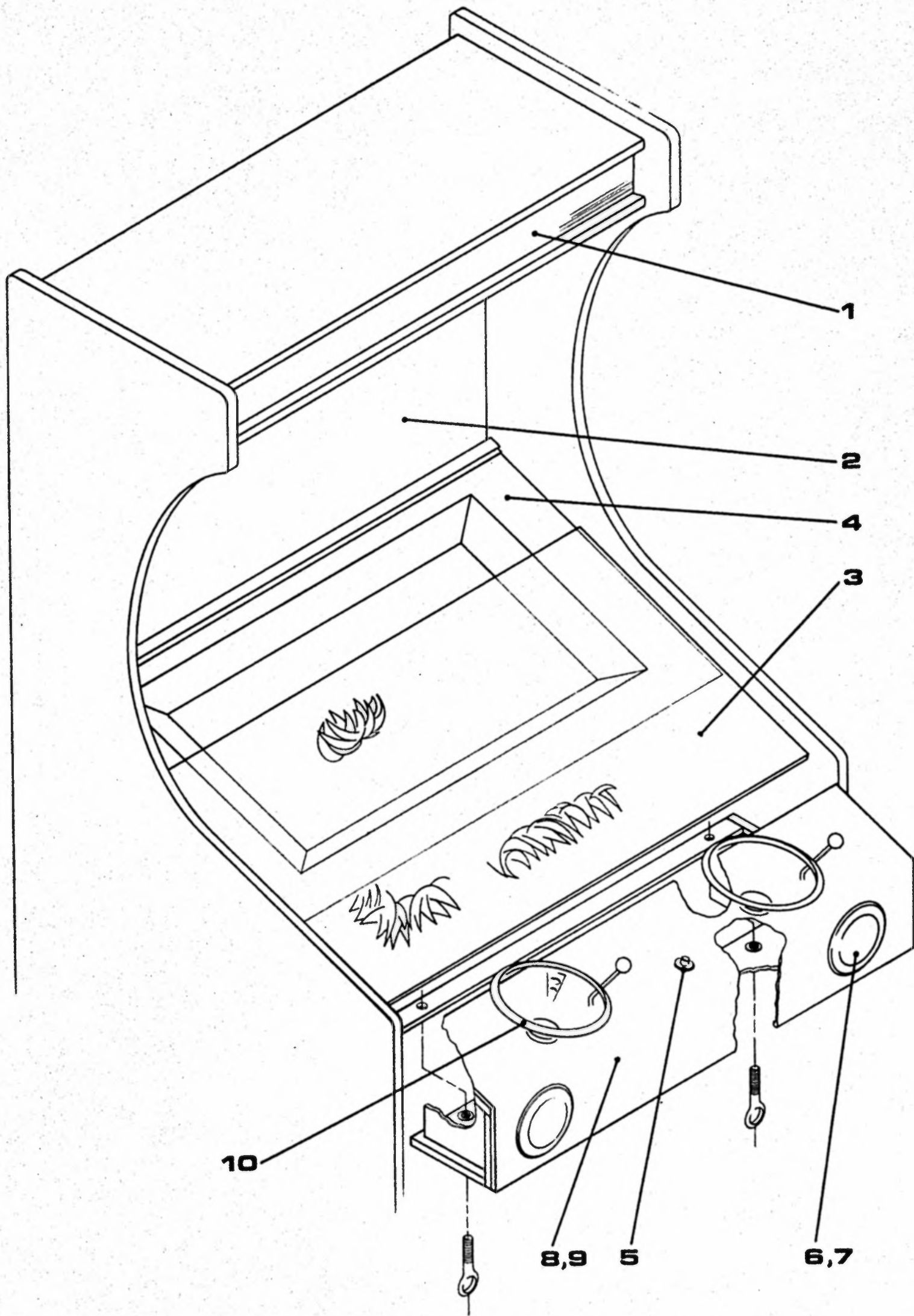

FIG 2

Figure No. 2		<b>EXIDY</b>
<b>ITEM</b>	<b>PART NO.</b>	<b>DESCRIPTION</b>
1.	DD-PLEX-4"	Plex panel "EXIDY"
2.	DD-PLEX-17"	Plex panel destruction derby
3.	DD-PLEX-19 $\frac{3}{4}$ "	Plex panel frame
4.	23" BEZEL	Bezel
5.	T936-DI-BLK.	Start switch
6.	4" SPKR.-GRL.	Speaker grill
7.	4" SPKR.	Speaker
8.	DD-ST-BOX-COMP.	Steering box complete
9.	DD-ST-BOX-EMPTY	Steering box (less P.C.B.'s & harness)
10.	82-2111	Steering wheel



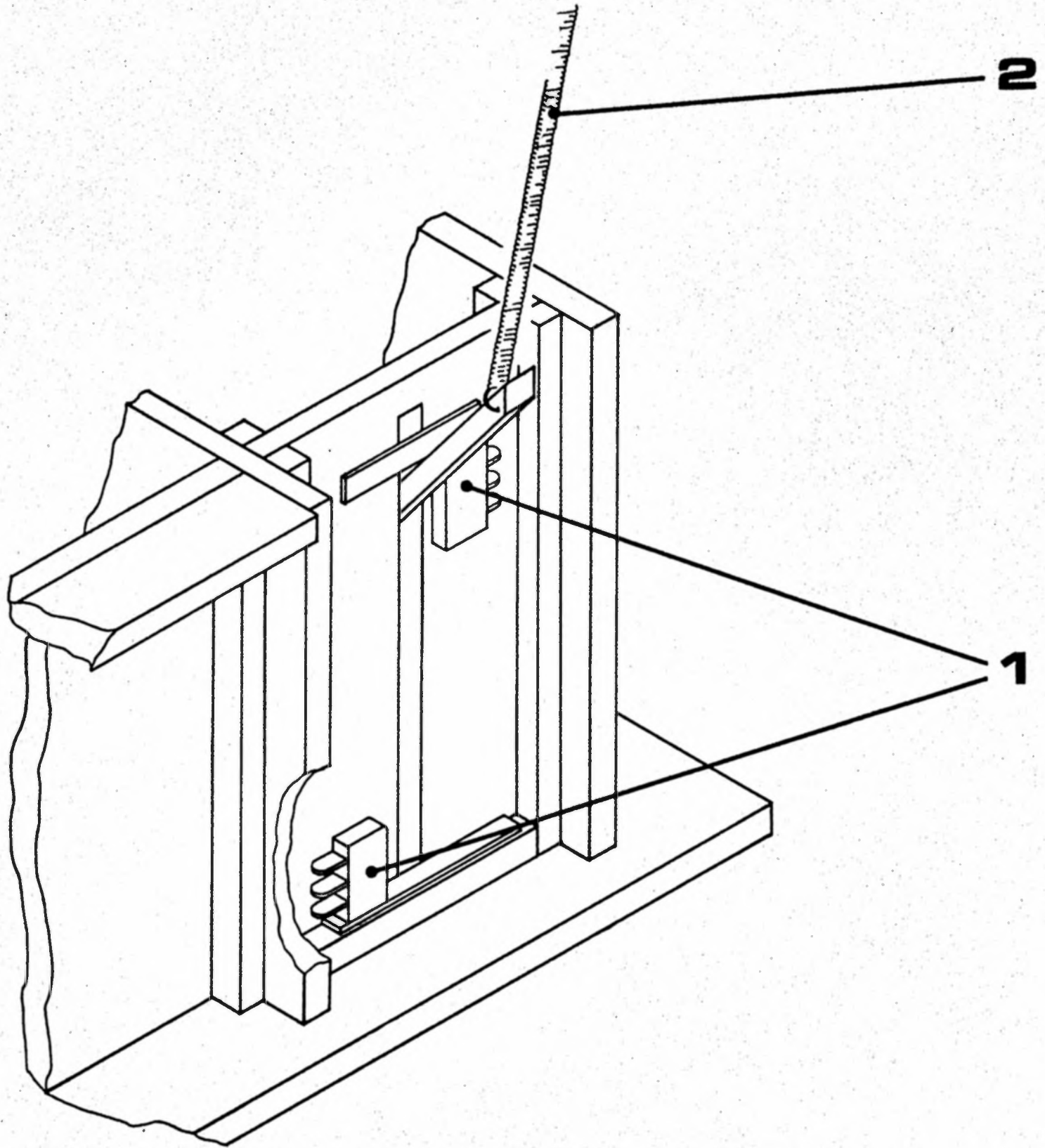

Figure No. 3		EXIDY
ITEM	PART NO.	DESCRIPTION
1.	E51-50R	Foot pedal micro switch
2.	DD-FP-SPRING	Foot pedal spring



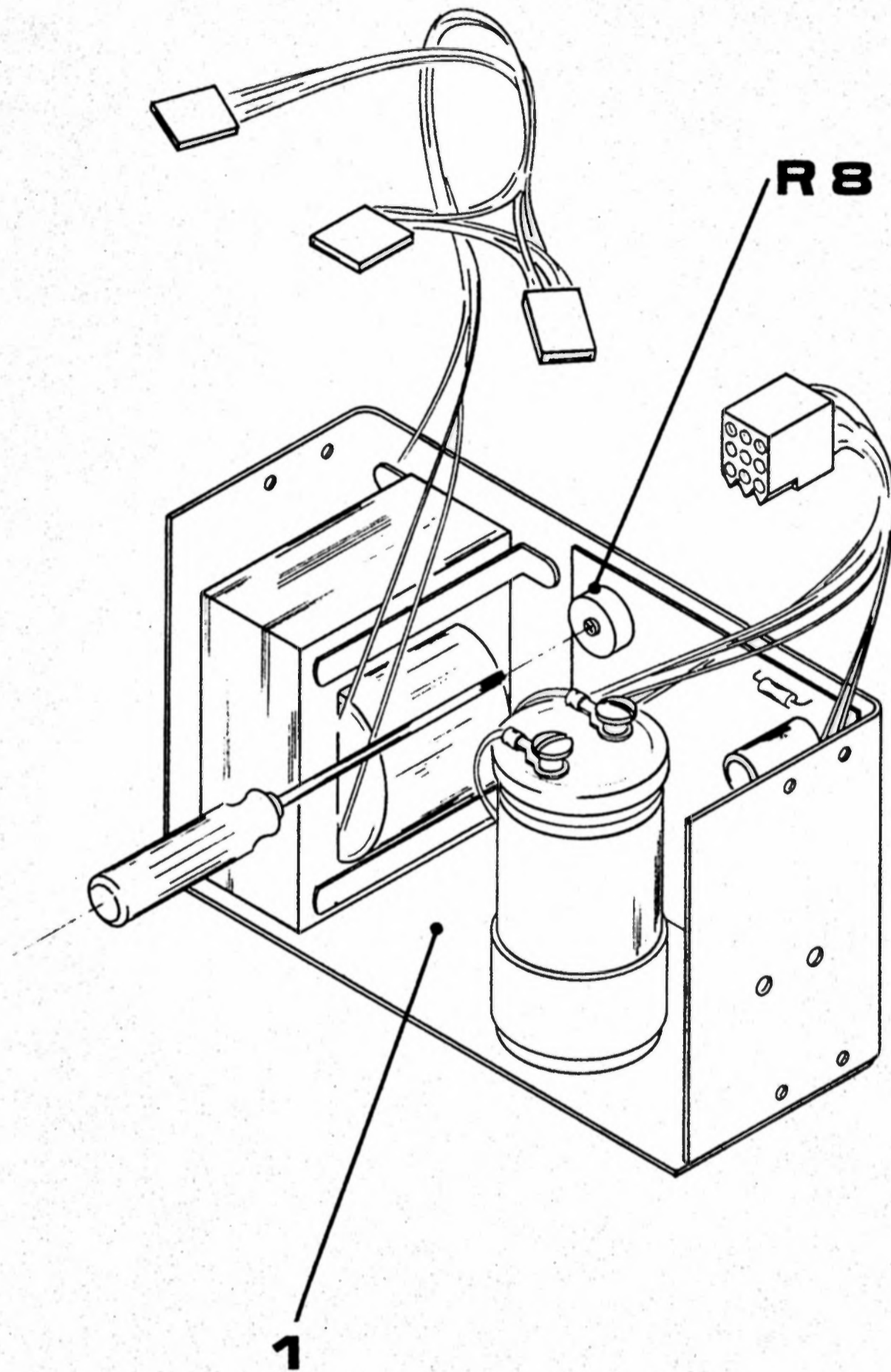

Figure No. 4		<b>EXIDY</b>
<b>ITEM</b>	<b>PART NO.</b>	<b>DESCRIPTION</b>
1.	EAPS-5-10	Power supply (including harness)



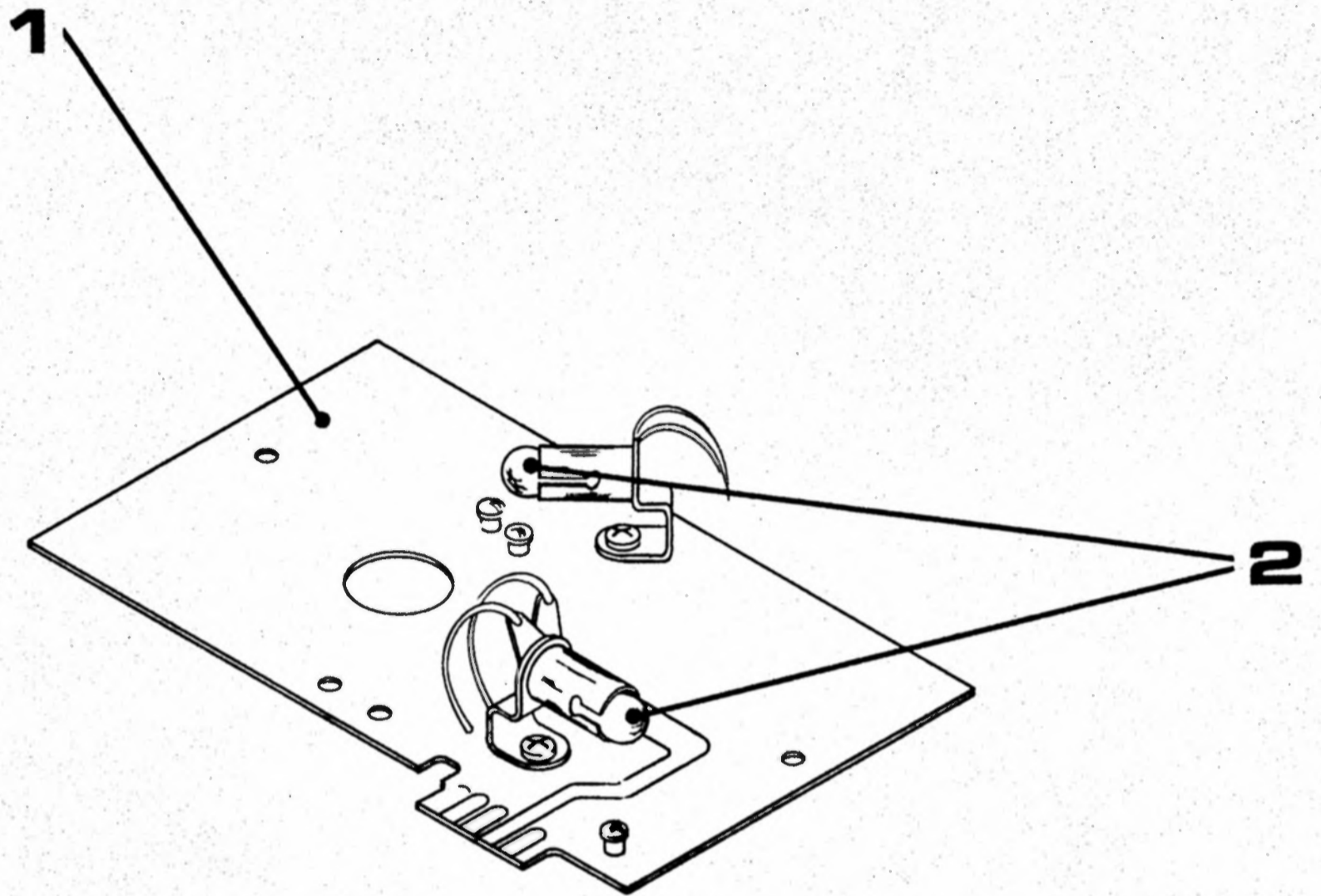
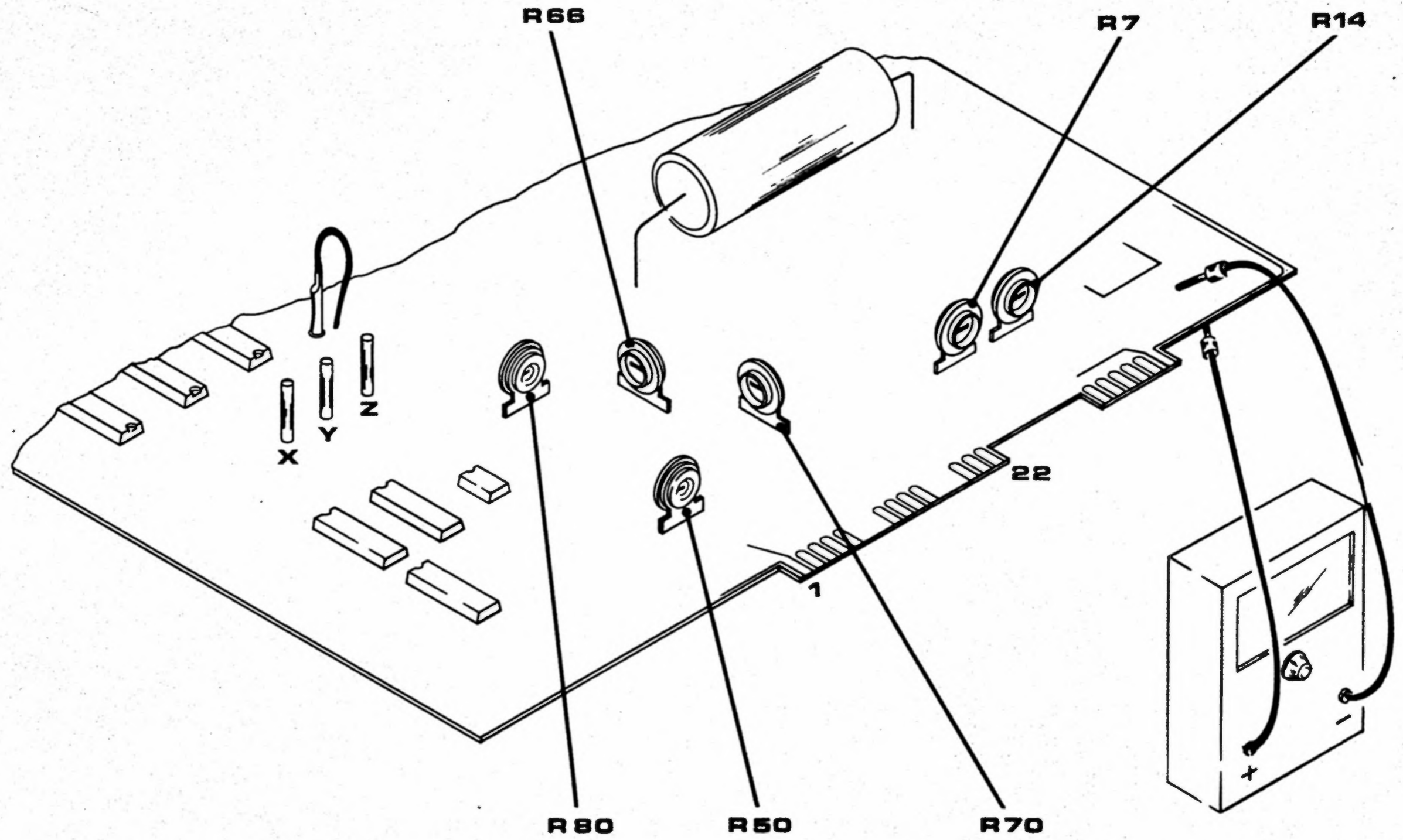

Figure No. 5		EXIDY
ITEM	PART NO.	DESCRIPTION
1.	DD-OCB-ST	Steering P.C.B.
2.	#47BULB	Twist lock bulb

**NOTE:**

The Filaments of the light bulbs on optical control boards (steering boards) must be properly aligned. The bulb over transistors marked "A", "B", must be directly between and over (in line with) both transistors. The bulb over transistor marked "S" must be directly over the transistor. Failure to align bulbs properly will result in faulty or intermittent steering. Alignment should be initially correct from factory.



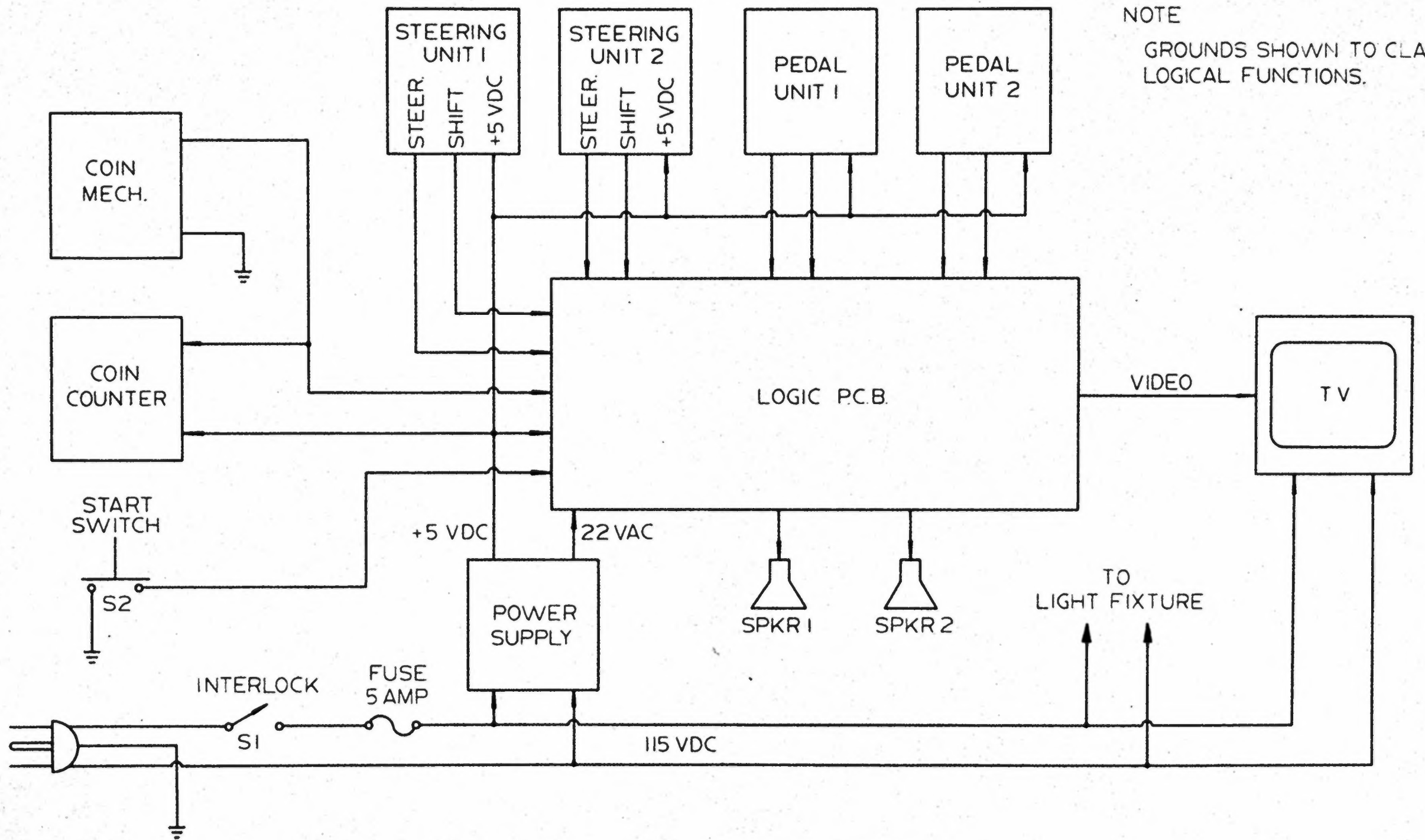

**FIG 6**



**FIG 7**

**DD SYSTEM BLOCK DIAGRAM**



NOTE  
GROUNDS SHOWN TO CLARIFY  
LOGICAL FUNCTIONS.

**FIG 8**  
DD WIRING DIAGRAM

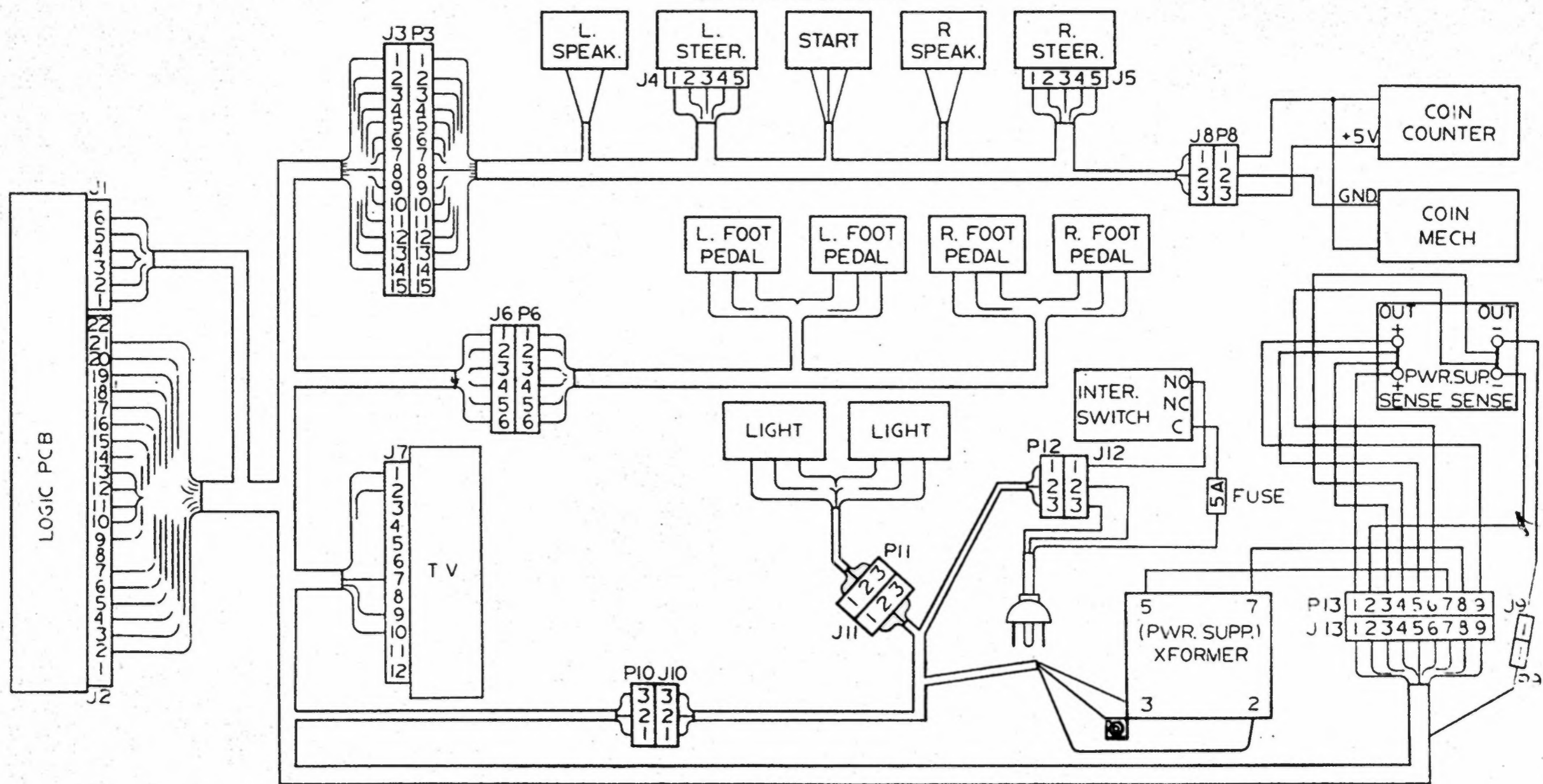
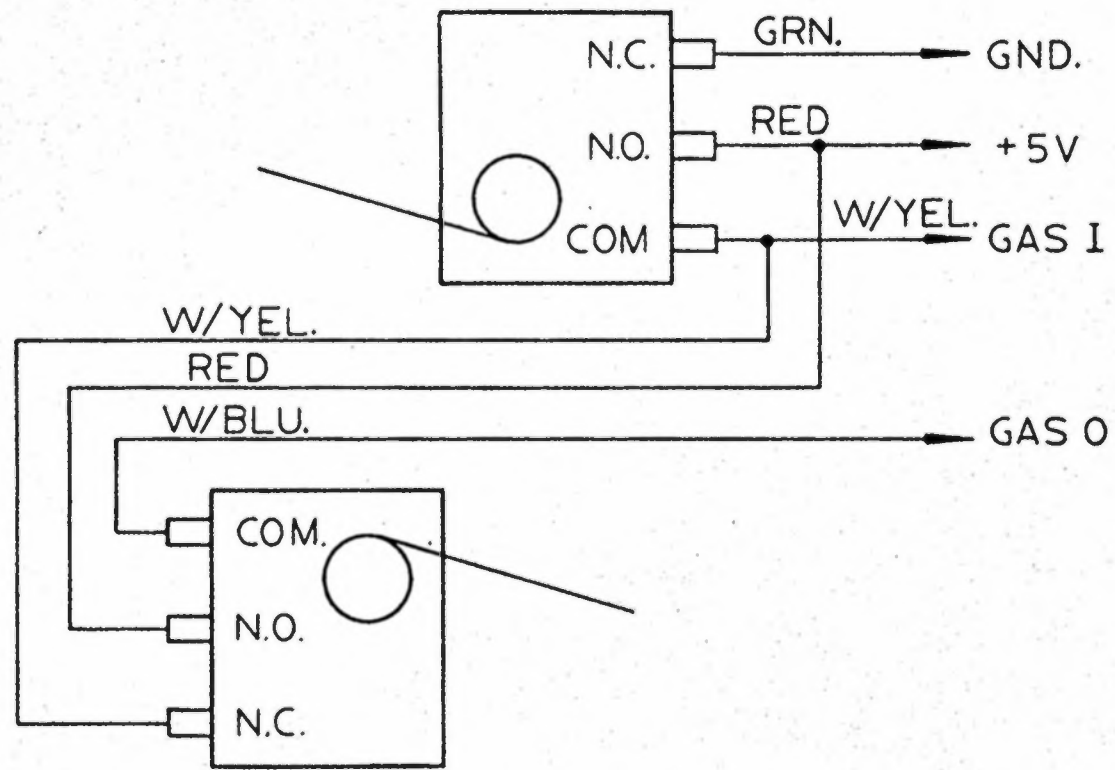

Figure No. 8

FROM:	TO:	FROM:	TO:	FROM:	TO:
J1 (PIN 1)	J13 (PIN 2)	P3 (PIN 11)	Left speaker	J7 (PIN 7)	P10 (PIN 3)
J1 (PIN 2)	J13 (PIN 1)	P3 (PIN 10)	Left speaker	J7 (PIN 10)	P10 (PIN 2)
J1 (PIN 3)	J13 (PIN 7)	P3 (PIN 13)	Right speaker	J7 (PIN 9)	P10 (PIN 1)
J1 (PIN 4)	J13 (PIN 8)	P3 (PIN 12)	Right speaker	J4 (PIN 2)	Start
J1 (PIN 5)	J13 (PIN 9)	P3 (PIN 9)	Start	J4 (PIN 1)	J5 (PIN 1)
J1 (PIN 6)	P9 (PIN 1)	P3 (PIN 14)	J8 (PIN 1)	P3 (PIN 1)	J8 (PIN 3)
J2 (PIN 2)	J3 (PIN 11)	P3 (PIN 5)	J4 (PIN 4)	P3 (PIN 1)	J8 (PIN 2)
J2 (PIN 3)	J3 (PIN 10)	P3 (PIN 4)	J4 (PIN 3)	P8 (PIN 3)	+5 V Coin counter
J2 (PIN 4)	J3 (PIN 13)	P8 (PIN 1)	Coin counter	P8 (PIN 2)	Ground coin mech.
J2 (PIN 5)	J3 (PIN 12)	P6 (PIN 4)	Foot pedal	P11 (PIN 1)	Light
J3 (PIN 9)	J2 (PIN 6)	P6 (PIN 3)	Foot pedal	P11 (PIN 1)	Light
J3 (PIN 14)	J2 (PIN 7)	P3 (PIN 3)	J4 (PIN 5)	P11 (PIN 2)	Light
J2 (PIN 9)	J3 (PIN 5)	P3 (PIN 8)	J5 (PIN 4)	P11 (PIN 2)	Light
J2 (PIN 10)	J3 (PIN 4)	P3 (PIN 7)	J5 (PIN 3)	P11 (PIN 3)	Light w safety ground
J2 (PIN 11)	J6 (PIN 4)	P6 (PIN 6)	Foot pedal	P11 (PIN 3)	Light w safety ground
J2 (PIN 12)	J6 (PIN 3)	P6 (PIN 5)	Foot pedal	J12 (PIN 1)	N.O. inter. switch
J2 (PIN 13)	J3 (PIN 3)	P3 (PIN 6)	J5 (PIN 5)	J12 (PIN 2)	To power cord
J2 (PIN 14)	J3 (PIN 8)	P13 (PIN 5)	+ Out sense	J12 (PIN 3)	To power cord
J2 (PIN 15)	J3 (PIN 7)	P13 (PIN 6)	- Sense	PWR cord	5 AMP fuse
J2 (PIN 16)	J6 (PIN 6)	P13 (PIN 3)	+ Sense	5A AMP fuse	Com. inter switch
J2 (PIN 17)	J6 (PIN 5)	P13 (PIN 4)	- Out	J10 (PIN 1)	J11 (PIN 1)
J2 (PIN 18)	J3 (PIN 6)	J13 (PIN 5)	J3 (PIN 1)	J10 (PIN 2)	J11 (PIN 2)
J7 (PIN 1)	J2 (PIN 20)	J13 (PIN 6)	J3 (PIN 2)	J10 (PIN 3)	J11 (PIN 3)
J2 (PIN 21)	J7 PIN 2)	J13 (PIN 3)	J6 (PIN 1)	J12 (PIN 3)	Safety ground
P13 (PIN 2)	- Sense (P.S.)	J13 (PIN 4)	J6 (PIN 2)	J12 (PIN 2)	#2 of xformer
P13 (PIN 1)	+ Sense (P.S.)	J13 (PIN 4)	J6 (PIN 2)	J12 (PIN 1)	#3 of xformer
P13 (PIN 7)	#5 of xformer	P3 (PIN 1)	J4 (PIN 1)	J11 (PIN 3)	P12 (PIN 3)
P13 (PIN 8)	#7 of xformer	P3 (PIN 2)	J4 (PIN 2)	J11 (PIN 2)	P12 (PIN 2)
P13 (PIN 9)	+ Out	P6 (PIN 1)	Foot pedal	J11 (PIN 1)	P12 (PIN 1)
J9 (PIN 1)	- Out	P6 (PIN 2)	Foot pedal		



**FIG 9**  
ACCELERATION



RIGHT PEDAL

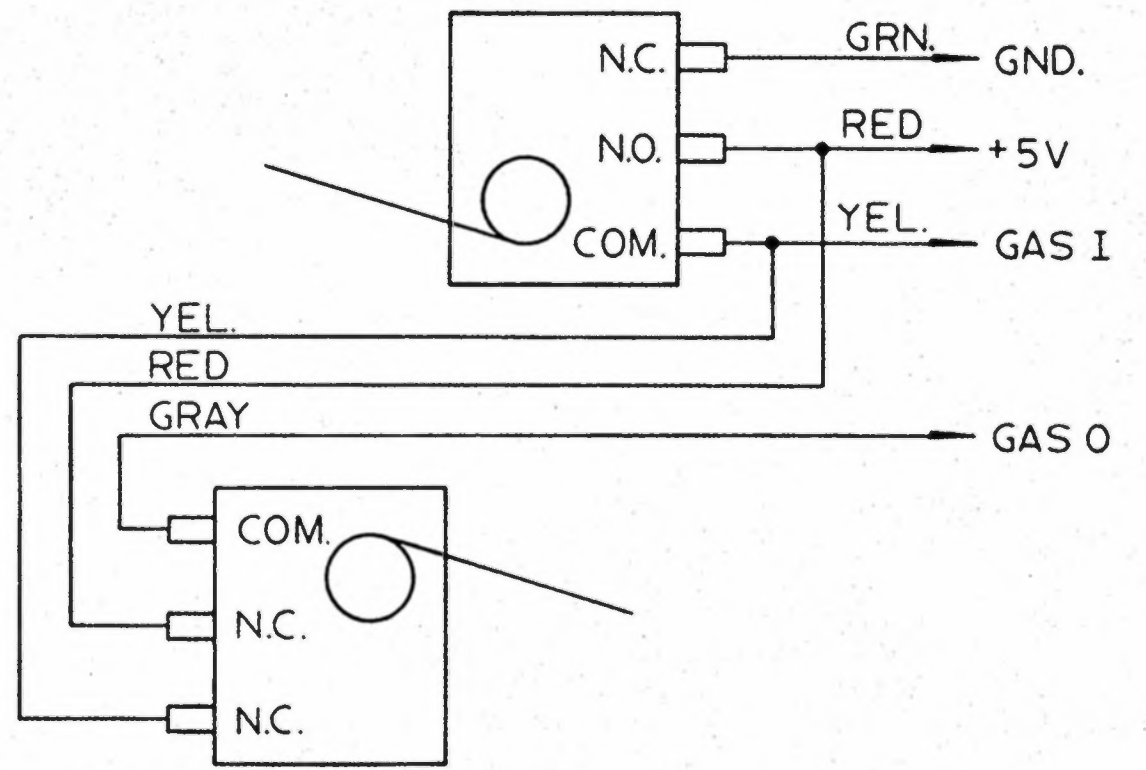

LEFT PEDAL

REAR VIEW

# EXIDY, INC.

166 San Lazaro Street  
Sunnyvale, California 94086  
(408) 733-1104

## ENGINEERING CHANGE NOTICE 1 (Destruction Derby)

**Purpose:** To update Destruction Derby Service Manual to include information about a different model printed circuit LOGIC board, labeled DD-2A.

### Instructions:

1. Add attached figure 6-A to Service Manual when applicable.
2. On page 4 of Service Manual add note below GAME TIME ADJUSTMENTS", to read as follows:

Note: On PCB labeled DD-2A  
Post 1 = 1 min. 20 sec.  
Unmarked Post = 1 min. 45 sec.  
Post 2 = 2 min. 15 sec.

### CAUTION

Installation of model DD-2A P.C. board requires 2 changes:

1. The 22 pin connector (P2) must be reversed from the direction it was installed on other models. If plugged in backwards loss of picture will result.
2. The DD-2A P.C. board is physically narrower than other models. A spacer has been installed in board mount on models equipped with DD-2A board from factory. WHEN ORDERING A NEW P.C. BOARD FROM THE FACTORY BE SURE TO SPECIFY WHETHER THE P.C. BOARD IN YOUR PRESENT UNIT IS A DD-2A. IF IT IS NOT A DD-2A THE FACTORY WILL SHIP A SPACER WITH ANY NEW DD-2A BOARD.

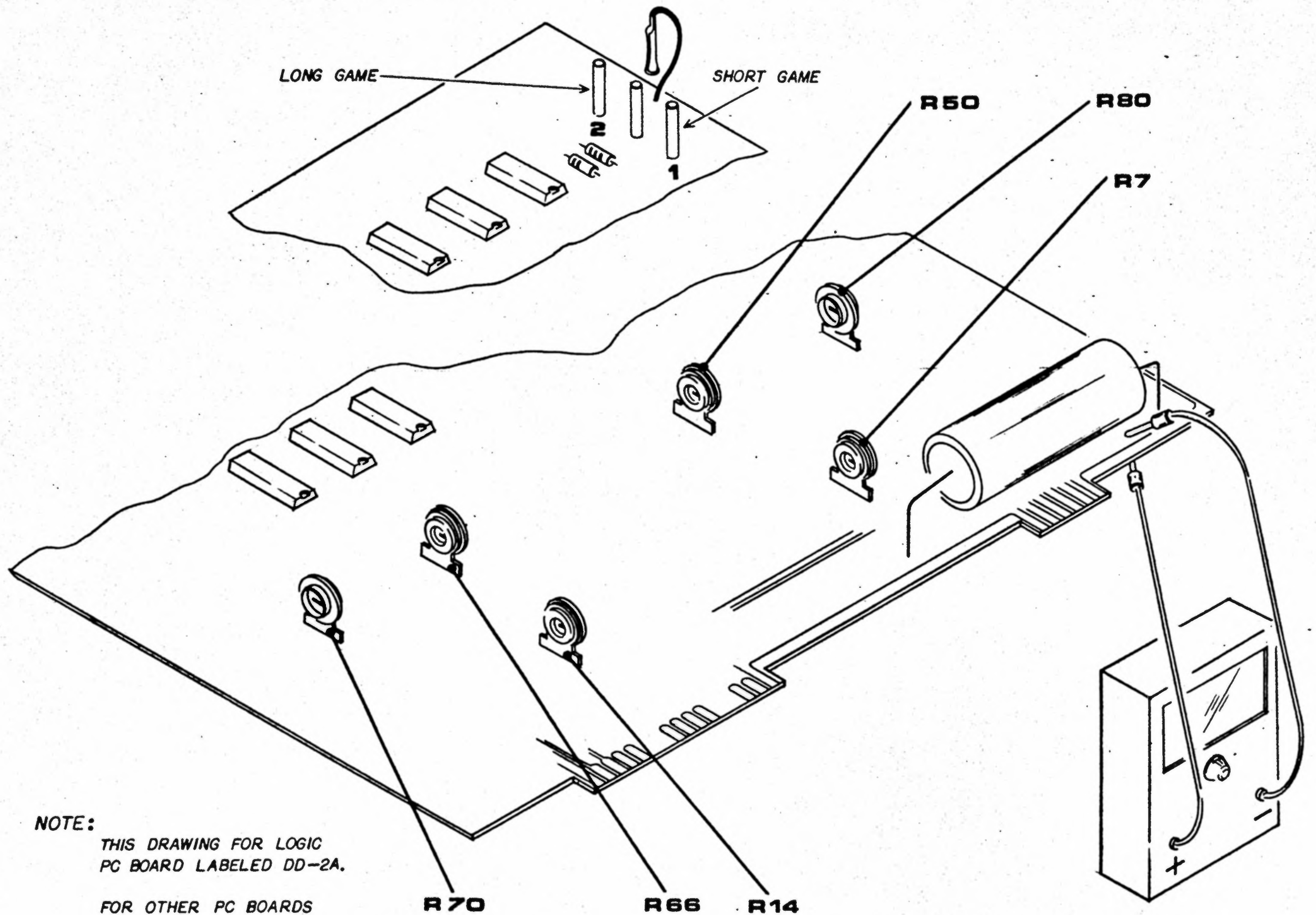

**NOTE:**

THIS DRAWING FOR LOGIC  
PC BOARD LABELED DD-2A.

FOR OTHER PC BOARDS  
SEE FIGURE 6.

**FIG 6A**  
**DD-2A**