

**GamePlan, inc.**

312-628-8200

# TENIGMA II

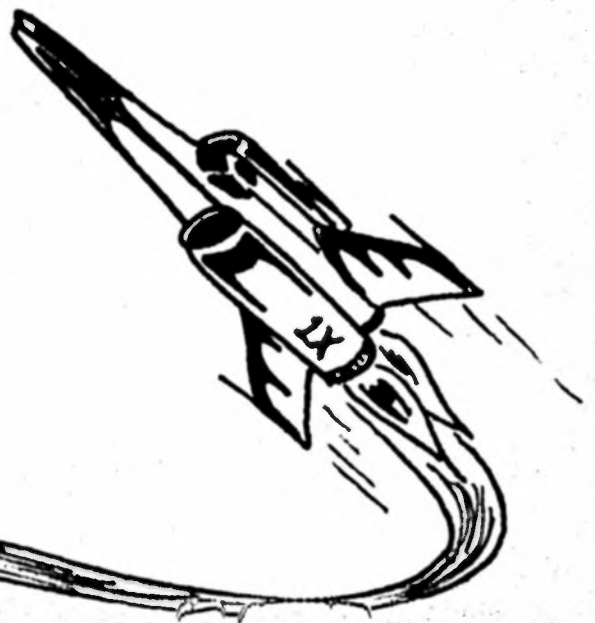
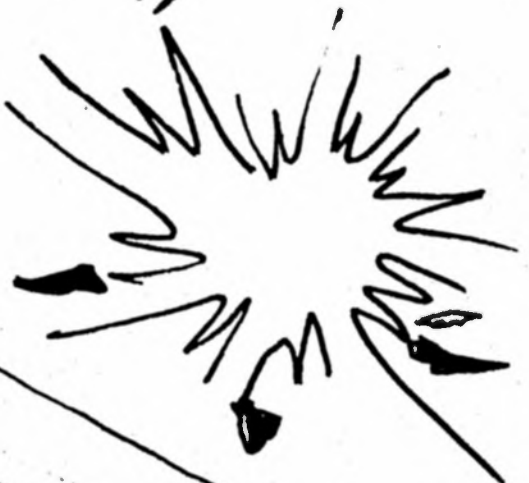
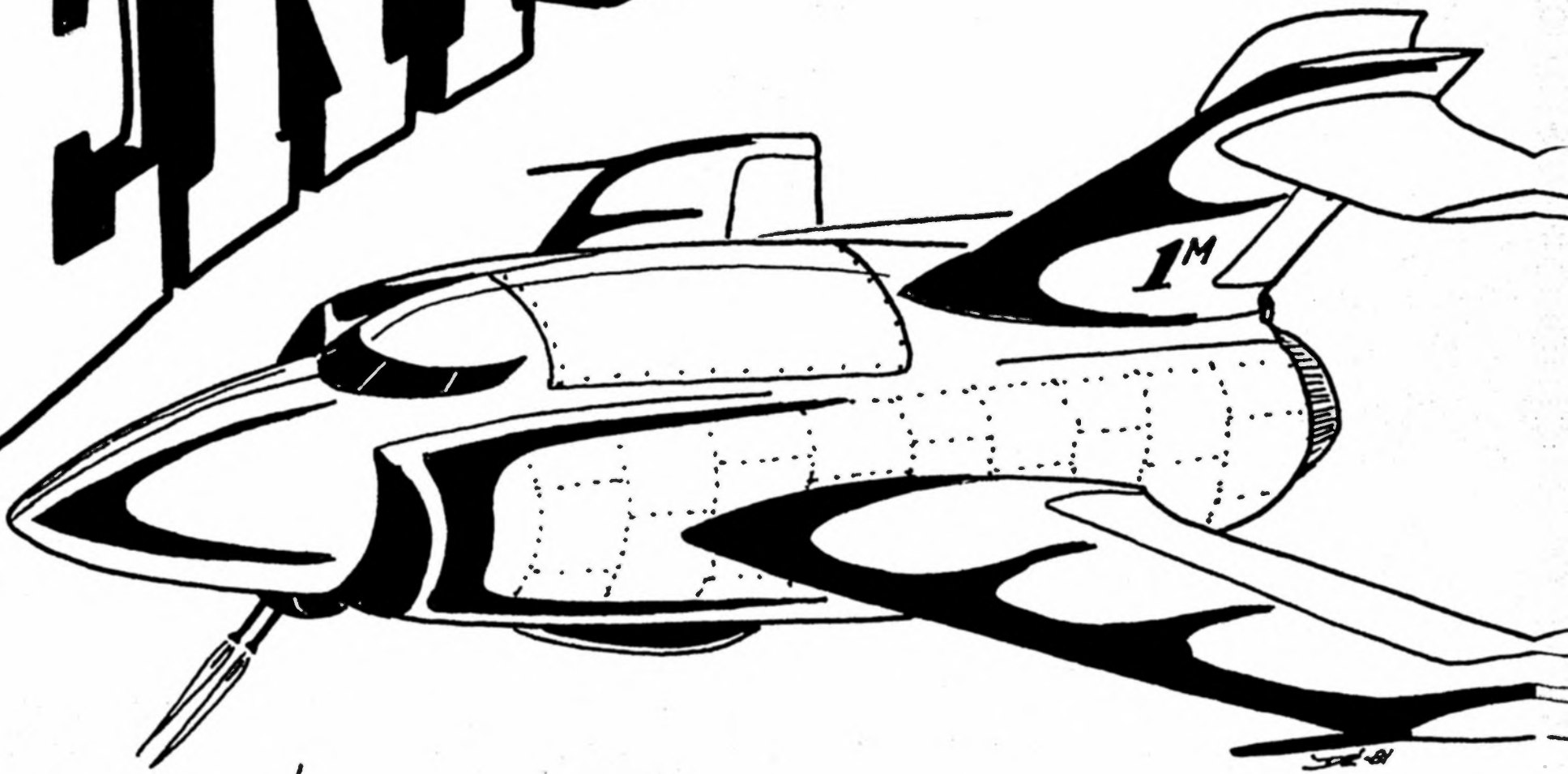

02-30079A

## **WARNING**

This equipment generates, uses, and can radiate radio frequency energy and, if not installed and used in accordance with the instructions manual, may cause interference to radio communications. As temporarily permitted by regulation it has not been tested for compliance [with the limits for Class A computing devices] pursuant to Subpart J of Part 15 of FCC Rules, which are designed to provide reasonable protection against such interference. Operation of this equipment in a residential area is likely to cause interference in which case the user, at his own expense, will be required to take whatever measures may be required to correct the interference.

## 1.0 INTRODUCTION

ENIGMA II is a 19", color, one or two player game, designed to capture and maintain player interest. It has a joystick for horizontal ship movement and thrust and fire buttons. The thrust button allows for vertical ship movement either to avoid bombs or to re-fuel. The fire button allows the player to destroy attacking aliens.

## 1.1 UNPACKING INSPECTION

To ensure the equipment incurred no damage in shipment, inspect the container prior to acceptance from the carrier. If no immediate cabinet damage is evident, perform the following visual inspection:

1. Open the rear of the game with the appropriate packaged key.
2. Examine each major and electrical component thoroughly for scrapes, broken or missing parts and loose or missing screws.
3. Check for loose cable connectors.
4. Visually verify that all the integrated circuit devices (IC's) plugged into sockets are properly seated and that no IC pins are bent or misaligned.

If you find any damage during this inspection, file a claim with the freight carrier, and send a complete report of the damage to Game Plan Inc.

## 1.2 INSTALLATION

Planning the location of the game should involve both physical and electrical consideration. Physical considerations concern the placement of the equipment with respect to clearances, AC cable and environmental conditions such as ventilation, temperature, weight support and accessibility (although your game has the durability to endure nearly every type of physical hazard). Electrical considerations include availability of the correct voltage and frequency.

In planning this installation, consideration must also be given to working space required for personnel involved with operation or maintenance of this system.

NOTE: The cabinet must be within six feet of an AC outlet. Be certain that a ground jack or terminal is available at the outlet.

CAUTION: DO NOT remove the AC ground prong from the plug.

- A. Install 4 provided levelers to bottom of cabinet and level cabinet.
- B. The power is controlled by a switch located on top of the cabinet plug into A.C. only 115 volt 60 cycle.

### CAUTION:

1. Do not install this game in places directly exposed to sunlight or excessive heat, to prevent rising internal temperatures.
2. High voltage runs the monitor. Therefore only persons familiar with safety measures should make any adjustments.
3. As with any solid state games the power should be turned off before replacing any parts or disconnecting any plugs.
4. Always take boards to distributor for repair, do not attempt to make any repairs with volt-ohmmeter or other test equipment as the internal voltage of such equipment may damage the circuitry.

## 1.3 PRELIMINARY CHECKOUT PROCEDURE

After properly installing ENIGMA II we suggest checking it's operation in the following procedure:

1. Plug the AC jack into the AC outlet.
2. Allow one to two minutes for CRT to warm up.
3. Observe the TV monitor display to assure the correct attract mode is present on the screen, as explained in Section 2.2.
4. If the ENIGMA II display is incorrect, correct immediately.
5. Insert a quarter into the coin slot.
6. Continue to play the game and verify that all screen images are displayed, once again, described in the Normal Operation procedure.

If repairs are necessary, contact your distributor or Game Plan Inc.

## 2.0 GAME DESCRIPTION

The following paragraphs describe the video images, sound effects, game strategy.

### 2.1 RESET MODE

Whenever power is applied (or momentarily interrupted), or the slam switch is activated the game does the following:

#### FIRST

1). Puts up test pattern and then goes into the attract mode.

#### SECOND

2). Erases any credits and sets or resets all scores to zero.

### 2.2 ATTRACT MODE

After power-up ENIGMA II, automatically cycles thru a sequence of video images that make up the attract mode. This consists of simulated first (1st) screen and Score Menu, simulated second (2nd) screen, and Score Menu simulated third (3rd) screen and Score Menu.

### 2.3 COIN INPUT MODE

At all times, while power is on, regardless of the game conditions or the operator options, the computer will accept a coin input, generate a unique sound, and increment the coin counter.

### 2.4 GAME START MODE

The computer scans the game-start switches only during the attract and game over modes and only then if the credit-count is not zero. When a start-switch is activated, the computer compares the operator selected credit option against the credit-count and ignores the switch if enough credits are not available. If there are sufficient credits, the computer subtracts the price of the selected game, resets the player scores to zero, generates the game-in play (GIP) sound, and displays the GIP message.

## 2.5 SINGLE PLAYER GAME

The game-play sequence in ENIGMA II consists of 3,4,5, or 6 turns (operator selectable) beginning with 16 or 32 aliens on the first screen, first turn (operator selectable), and skill level 1 thru 6 (operator selectable) Each turn lasts as long as the player can skillfully maneuver his ship to avoid destruction while destroying aliens. When he loses a ship, the GIP message, reappears (stating whose turn it is) accompanied by the (GIP) sound, while the computer re-draws the remaining fuel (bottom of screen and displays the total number of ships left below the players score (upper left hand portion of the screen.) After the last ship is lost or fuel has been used the game-over message is displayed. NOTE: a player loses his ship via the following:

1. Being hit by a bomb dropped from an alien, bombs cannot be shot down and must be avoided.
2. When a bomb explodes, if the players ship is in the blast area, the round ends.
3. Being hit, directly by an alien, causes the player to lose a ship, the alien will re-appear on the next turn-all aliens must be destroyed using the fire button.
4. Aliens when reaching the bottom level, will leave a bomb and move back up, this bomb and its blast area must be avoided.
5. Thrusting into an alien, alien bomb, stars, etc.
6. During the docking maneuver missing the docking port will cause the players ship to explode.

Assuming a 4 ship, 16 first screen aliens, with a beginning skill level of 2. Play begins with the player score 000000 and 3 ships displayed immediately below it. When the fuel gauge is completely filled the ship displayed right above it will react to the controls-left-right, thrust and fire, 16 aliens will be displayed and begin moving left to right irregularly, some descending, some dropping thin bombs, which have no blast area. The player uses his joystick to move his ship left or right to avoid the bombs while firing upward to destroy the attackers. NOTE: rapid fire causes the ships shots to have a limited range and use more fuel.

Whenever a player destroys an attacker a distinctive sound is heard and his score is increased if an alien reaches the bottom and lays a bomb and then retreats the bomb will be detonated by other alien bombs and must be avoided, only one bomb of this type will be on the bottom level these bombs by holding the thrust button down, causing the ship to lift off and by using the joystick the ship can jump over these bombs, remembering that thrusting uses up fuel.

When all the aliens in the first round have been destroyed a tune is played and a completely different group of aliens is displayed in the second round, 16 big bugs, when one of these creatures are hit, 2 things happen a big bomb is released and the big bug is replaced by a winged alien which attacks the players ship by diving toward it, sometimes laying down a surface bomb.

When the player loses a ship the round is over. The computer displays the G-I-P message and re-draws the screen with the remaining correct number of aliens and re-displays the remaining fuel left. If the player before the end of the game should get thru the 2nd screen, the 3rd screen will appear with 12 rectangles, these rectangles cannot be shot, but

## 2.5 SINGLE PLAYER GAME

Con't

they house aliens which swoop and dive in short attack the players' ship. Should the player be skillful enough to complete this round the next round is a starfield with a large cruiser slowly moving across the top while raining bombs, each time the cruiser is hit in the mid-ship a bomb is released, on the fourth (4th) hit, the cruiser explodes, then the re-fueling ship appears and the player must dock with this ship to get a full fuel tank, while avoiding colliding with any stars, using the thrust button, and the joystick. One pass across the top, or crashing into the fuel ship causes the round to end. If successful the 1st round will then re-appear with 32 aliens at the next skill level. So in this game the next level would be three (3). Every five (5) screens shifts the skill level automatically all of these features make ENIGMA II challenging to the player and profitable for the operator.

The game is over when all the ships have been destroyed or fuel used up.

## 2.6 TWO-PLAYER MODE

The play of ENIGMA II in a two-player game is identical to single-play with the players alternating turns. On the Upright Version, the players use one common set of controls. On the cocktail version there are two sets of controls on opposite sides of the table. The computer activated control alternately between 1 and 2 flip-flops the screen image so that it is oriented to the player in control.

The GIP message, which appears after each turn, clearly indicates which player is up this allows time for the players to position themselves at the controls, but is brief enough to avoid unnecessary "dead-time".

## 2.7 GAME OVER MODE

After the players have lost their last ship the game over message is displayed and the attract mode begins. If there are credits left or a coin is inserted, the attract mode will be interrupted by pressing the start button.

### 3.0 OPERATOR OPTIONS

The standard options for ENIGMA II are

<u>NUMBER OF SHIPS</u>	<u>SW</u>	<u>1</u>	<u>-</u>	<u>2</u>
3		ON		ON
4		OFF		ON
5		ON		OFF
6		OFF		OFF

<u>GAME</u>		3
U/R		ON
T/T		OFF

<u>COINAGE</u>		4
1 COIN- 1 PLAY		ON
2 COINS-1 PLAY		OFF

NUMBER OF INVADERS 1st. SCREEN 1st. ROUND SW 5

16 INVADERS		OFF
32 INVADERS		ON

<u>SKILL LEVEL</u>	<u>SW</u>	<u>6</u>	<u>-</u>	<u>7</u>	<u>-</u>	<u>8</u>
1		OFF		ON		OFF
2		OFF		ON		ON
3		OFF		OFF		OFF
4		OFF		OFF		ON
5		ON		OFF		OFF
6		ON		OFF		ON

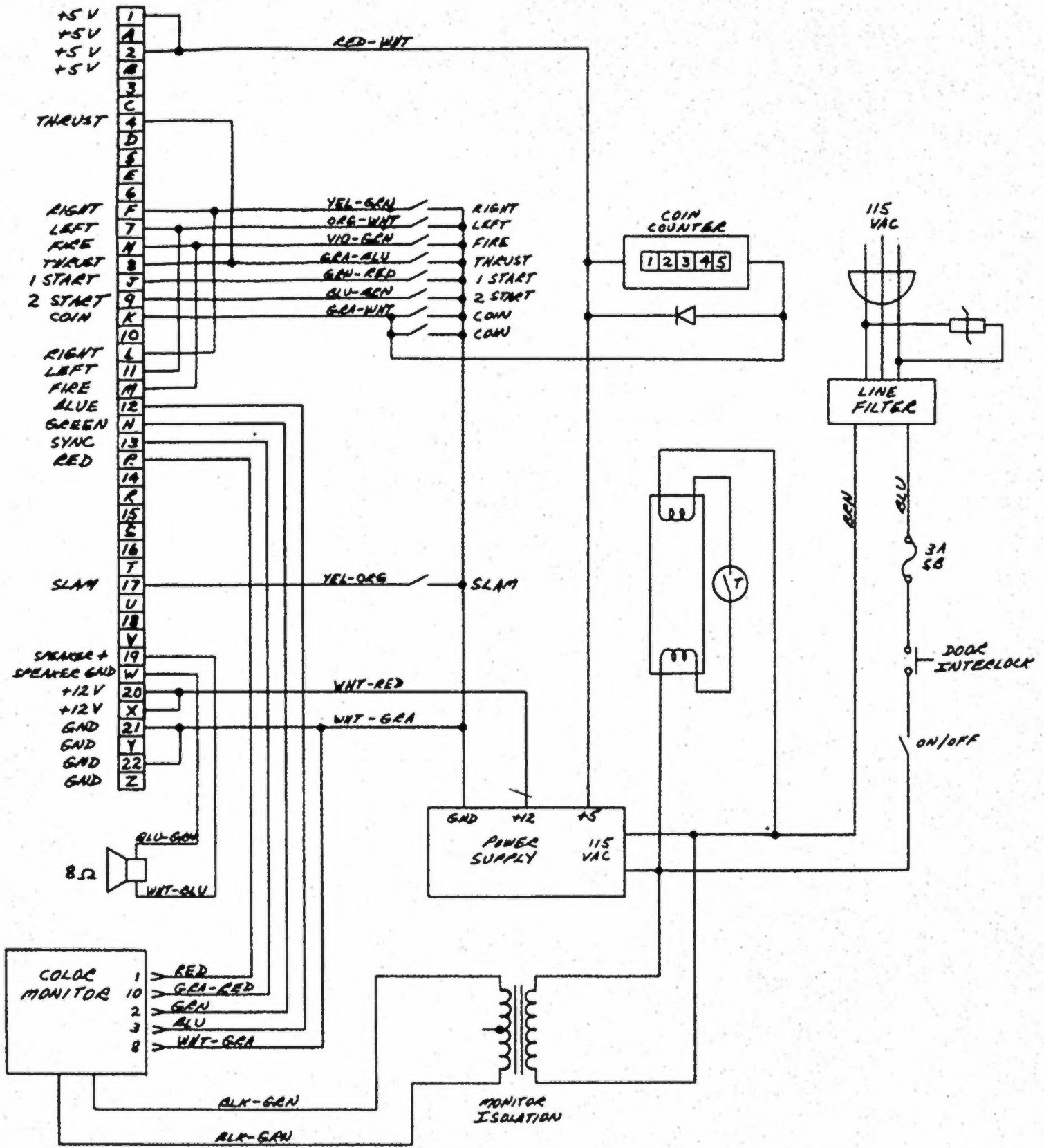

ISSUE	CHANGE	DATE	<table border="1"> <tr> <td>Use On</td> <td colspan="3">GAME PLAN Inc. 1515 W. Fullerton Ave Addison ILL. 60101</td> </tr> <tr> <td>PARTS MUST BE CLEAN AND FREE OF BURRS</td> <td>Scale</td> <td>Finish</td> <td>Drawn By <i>JHW</i></td> </tr> <tr> <td>Tolerances Unless Specified</td> <td>Date 10-16-81</td> <td>Am't</td> <td>App. By</td> </tr> <tr> <td>Fractional ----- ± .015</td> <td colspan="3">Mat'l</td> </tr> <tr> <td>Decimal ----- ± .005</td> <td colspan="3">Drawing Number 02-70109C</td> </tr> <tr> <td>Angles ----- ± 1/2</td> <td colspan="3">ENIGMA CABINET</td> </tr> <tr> <td>Screw Threads ----- Class 2</td> <td colspan="3"></td> </tr> </table>	Use On	GAME PLAN Inc. 1515 W. Fullerton Ave Addison ILL. 60101			PARTS MUST BE CLEAN AND FREE OF BURRS	Scale	Finish	Drawn By <i>JHW</i>	Tolerances Unless Specified	Date 10-16-81	Am't	App. By	Fractional ----- ± .015	Mat'l			Decimal ----- ± .005	Drawing Number 02-70109C			Angles ----- ± 1/2	ENIGMA CABINET			Screw Threads ----- Class 2			
Use On	GAME PLAN Inc. 1515 W. Fullerton Ave Addison ILL. 60101																														
PARTS MUST BE CLEAN AND FREE OF BURRS	Scale	Finish	Drawn By <i>JHW</i>																												
Tolerances Unless Specified	Date 10-16-81	Am't	App. By																												
Fractional ----- ± .015	Mat'l																														
Decimal ----- ± .005	Drawing Number 02-70109C																														
Angles ----- ± 1/2	ENIGMA CABINET																														
Screw Threads ----- Class 2																															

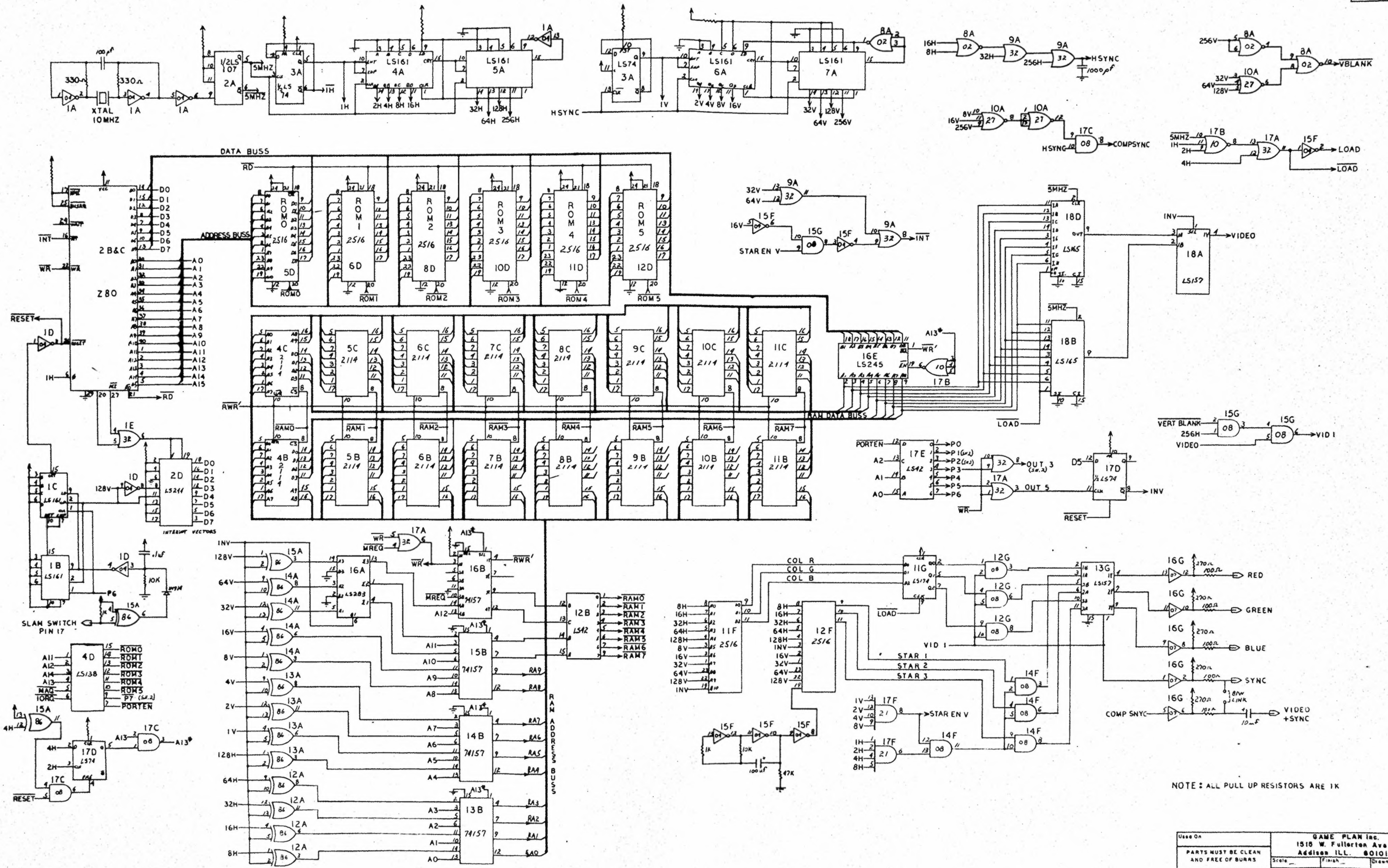

NOTE: ALL PULL UP RESISTORS ARE 1K

Use On	GAME PLAN Inc. 1518 W. Fullerton Ave Addison ILL. 60101		
PARTS MUST BE CLEAN AND FREE OF BURRS	Scale	Finish	Drawn By
Tolerances Unless Specified	Date 10/16/81	App. By	
Fractional	± 0.05		Drawing Number 02-70108 CD
Decimal	± 0.005		ENIGMA II PCB SCHEMATIC
Angles	± 1/2°		SHEET 1 OF 2
Issue	CHANGE	DATE	

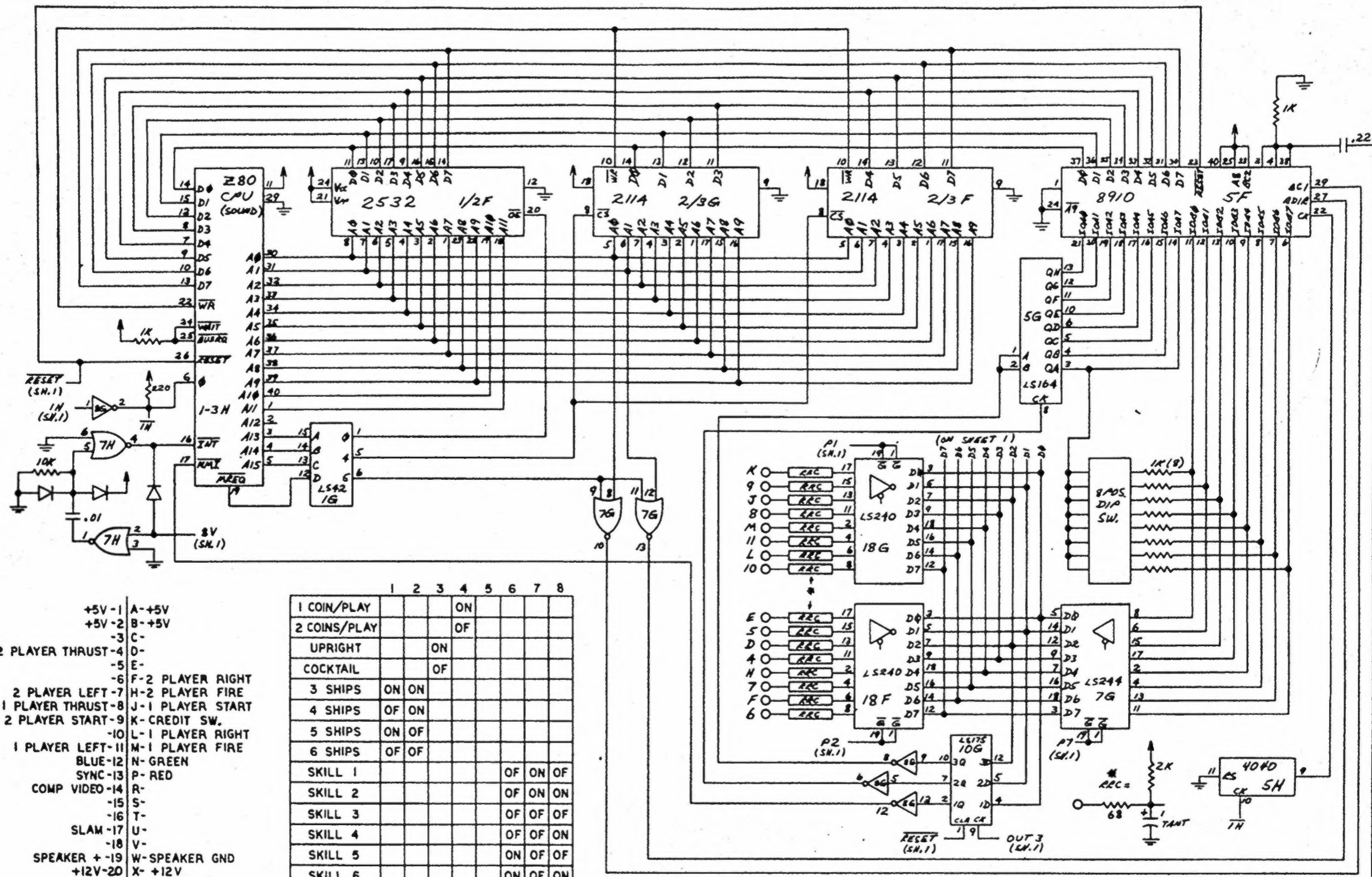

- +5V-1 A-+5V
- +5V-2 B-+5V
- 3 C-
- 2 PLAYER THRUST-4 D-
- 5 E-
- 6 F-2 PLAYER RIGHT
- 2 PLAYER LEFT-7 H-2 PLAYER FIRE
- 1 PLAYER THRUST-8 J-1 PLAYER START
- 2 PLAYER START-9 K-CREDIT SW.
- 10 L-1 PLAYER RIGHT
- 1 PLAYER LEFT-11 M-1 PLAYER FIRE
- BLUE-12 N- GREEN
- SYNC-13 P- RED
- COMP VIDEO-14 R-
- 15 S-
- 16 T-
- SLAM-17 U-
- 18 V-
- SPEAKER + -19 W-SPEAKER GND
- +12V-20 X- +12V
- GND-21 Y- GND
- GND-22 Z- GND

EDGE CONNECTOR

	1	2	3	4	5	6	7	8
1 COIN/PLAY								ON
2 COINS/PLAY								OF
UPRIGHT				ON				
COCKTAIL				OF				
3 SHIPS	ON	ON						
4 SHIPS	OF	ON						
5 SHIPS	ON	OF						
6 SHIPS	OF	OF						
SKILL 1						OF	ON	OF
SKILL 2						OF	ON	ON
SKILL 3						OF	OF	OF
SKILL 4						OF	OF	ON
SKILL 5						ON	OF	OF
SKILL 6						ON	OF	ON
16 INVADERS						OF		
32 INVADERS						ON		

SWITCH SETTINGS

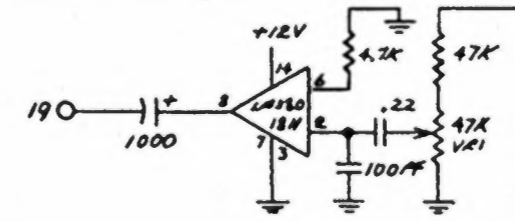

Use On	GAME PLAN Inc. 1518 W. Fullerton Ave Addison ILL. 60101		
PARTS MUST BE CLEAN AND FREE OF BURRS	Scale	Finish	Drawn By <i>JW</i>
Tolerances Unless Specified	Date 10-13-81	Ant	Ass By
Fractional . . . . . ± .015	Mat'l		
Decimal . . . . . ± .005	Drawing Number 02-70108CD		
Angles . . . . . ± 1/2°	ENIGMA II SHEET 2 OF 2		
Screw Threads . . . . . Class 2			

ISSUE	CHANGE	DATE