

Paul 2-23-29

TM-075
2nd printing



flyball™



Operation, Maintenance
and Service Manual

WARRANTY

Seller warrants that its printed circuit boards and parts thereon are free from defects in material and workmanship under normal use and service for a period of ninety (90) days from date of shipment. Seller warrants that its television monitors are free from defects in material and workmanship under normal use and service for a period of thirty (30) days from date of shipment. None of the Seller's other products or parts thereof are warranted.

If the products described in this manual fail to conform to this warranty, Sellers' sole liability shall be, at its option, to repair, replace, or credit Buyer's account for such products which are returned to Seller during said warranty period, provided:

- (a) Seller is promptly notified in writing upon discovery by Buyer that said products are defective;
- (b) Such products are returned prepaid to Sellers' plant; and
- (c) Seller's examination of said products discloses to Seller's satisfaction that such alleged defects existed and were not caused by accident, misuse, neglect, alteration, improper repair, installation or improper testing.

In no event shall Seller be liable for loss of profits, loss of use, incidental or consequential damages.

EXCEPT FOR ANY EXPRESS WARRANTY SET FORTH IN A WRITTEN CONTRACT BETWEEN SELLER AND BUYER WHICH CONTRACT SUPERSEDES THE TERMS OF THIS ORDER, THIS WARRANTY IS EXPRESSED IN LIEU OF ALL OTHER WARRANTIES EXPRESSED OR IMPLIED, INCLUDING THE IMPLIED WARRANTIES OF MERCHANTABILITY AND FITNESS FOR A PARTICULAR PURPOSE, AND OF ALL OTHER OBLIGATIONS OR LIABILITIES ON THE SELLER'S PART, AND IT NEITHER ASSUMES NOR AUTHORIZES ANY OTHER PERSON TO ASSUME FOR THE SELLER ANY OTHER LIABILITIES IN CONNECTION WITH THE SALE OF PRODUCTS UNDER THIS ORDER.



This document is and contains confidential trade secret information of Atari, Inc.

This document is loaned under confidential custody for the sole purpose of operation, maintenance or repair of Atari equipment and may not be used by or disclosed to any person for any other purpose whatever, and remains the property of Atari, Inc.

Neither it nor the information it contains may be reproduced, used, or disclosed to persons not having a need to know consistent with the purpose of the loan, without written consent of Atari, Inc.

Flyball™

Operation, Maintenance
and Service Manual

ATARI INC.
14600 WINCHESTER BLVD
LOS GATOS, CA 95030
(408) 374-2440 • TELEX 357-488

By the Publications Group, Engineering Department



ATARI™
Innovative
leisure

All rights reserved. Copyright © 1976 by Atari, Inc.

No part of this publication may be reproduced by any mechanical, photographic, or electronic process, or in the form of a phonographic recording, nor may it be stored in a retrieval system, transmitted, or otherwise copied for public or private use, without permission from the publisher.

For permission requests, write:

Atari, Inc.
Engineering Dept.
Publications Group
14600 Winchester Blvd.
Los Gatos, Calif. 95030

Table of Contents

<i>Subject</i>	<i>Page</i>
I. INTRODUCTION	1
1.1 <i>Physical Description of Game</i>	1
1.2 <i>Summary of Game Play</i>	1
II. SPECIFICATIONS	3
2.1 <i>General</i>	3
2.2 <i>Electrical</i>	3
2.3 <i>Environmental</i>	3
2.4 <i>Owner/Operator Options for Structuring of Play</i>	3
2.5 <i>Accessories Available on Separate Order</i>	3
III. THEORY OF OPERATION	5
3.1 <i>Functional Description of Game</i>	5
3.2 <i>General Information</i>	5
3.2.1 <i>Energizing the Game</i>	
3.2.2 <i>TV Monitor</i>	
3.2.3 <i>Picture on TV Screen</i>	
3.3 <i>Game Sequence</i>	7
3.3.1 <i>Operating Modes</i>	
3.3.2 <i>Attract Mode</i>	
3.3.3 <i>Game Sequence in Play Mode</i>	
3.3.4 <i>Owner/Operator Options</i>	
3.4 <i>Detailed Technical Description of Operation</i>	9
3.4.1 <i>General Information</i>	
3.4.2 <i>Sheet 6 of Schematic</i>	
3.4.3 <i>Sheet 1 of Schematic</i>	
3.4.4 <i>Sheet 2 of Schematic</i>	
3.4.5 <i>Sheet 3 of Schematic</i>	
3.4.6 <i>Sheet 4 of Schematic</i>	
3.4.7 <i>Sheet 5 of Schematic</i>	
3.4.8 <i>Sheet 7 of Schematic</i>	

Table of Contents

IV. INSTALLATION INSTRUCTIONS	13
4.1 <i>Unpacking Instructions</i>	13
4.1.1 <i>Examination for Shipping Damage</i>	
4.1.2 <i>Mechanical Inspection</i>	
4.2 <i>Energizing the Game</i>	14
4.2.1 <i>Application of AC Power</i>	
4.2.2 <i>Check on Operation of Interlock Switches</i>	
4.3 <i>Game Structuring</i>	14
4.4 <i>Functional Check of Game Operation</i>	15
4.4.1 <i>Check of Attract Mode</i>	
4.4.2 <i>Check of Play Mode</i>	
V. MAINTENANCE AND ADJUSTMENTS	17
5.1 <i>Routine Maintenance</i>	17
5.1.1 <i>Cleaning</i>	
5.1.2 <i>Lubrication</i>	
5.2 <i>Adjustments on TV Monitor</i>	17
5.3 <i>Adjustment of Speaker Volume</i>	18
5.4 <i>Adjustment of Potentiometers on Joystick Assemblies</i>	18
VI. TROUBLESHOOTING AND REPAIR	23
6.1 <i>General Procedure</i>	23
6.1.1 <i>Identifying the Trouble Area</i>	
6.1.2 <i>Locating the Trouble Cause</i>	
6.1.3 <i>Correcting the Trouble Cause</i>	
6.1.4 <i>Verifying Correct Game Operation</i>	
6.2 <i>Test Equipment</i>	24
6.2.1 <i>Basic Test Equipment</i>	
6.2.2 <i>Optional Test Equipment</i>	
6.3 <i>Specific Troubleshooting Information</i>	26
6.3.1 <i>Coin Mechanism</i>	
6.3.2 <i>TV Monitor</i>	
6.3.3 <i>Joystick-Related Trouble Symptoms</i>	
VII. SCHEMATICS, DRAWINGS, AND PARTS LISTS	29

I. INTRODUCTION

1.1 PHYSICAL DESCRIPTION OF GAME

Atari's "Flyball" is a baseball video action game for two players. The game is packaged in its own distinctively-styled upright cabinet that rests directly on the floor. A 19-inch black-and-white TV monitor is mounted inside the cabinet, with the monitor chassis tilted back in a nearly horizontal position. The two players stand side by side in front of the cabinet, looking down at the picture on the TV screen. (Drawing number A005292 in Section VII of this manual shows external and section views of the cabinet.) The TV screen is surrounded by a bezel upon which a baseball stadium graphics design has been printed. A transparent plexiglass panel is placed in front of the bezel, at a distance of a few inches above the surface of the picture tube.

The player-operated controls are mounted on a panel at the front of the cabinet, between the players and the TV screen. The controls consist of two joystick levers, one for each player, and two push button switches. One switch is backlit and has the words TWO PLAYER START engraved on the button; the other switch is not backlit and the words "Press button to hold runner!" are printed on the panel above the button. Instruction diagrams for operating the joysticks are also printed on the panel near each joystick.

Two identical coin mechanisms are mounted on the front of the cabinet, below the player controls. They accept quarters only and are connected so that either one can initiate play. The cash box is located behind a locked access door to the coin mechanisms. A speaker is mounted in the top portion of the cabinet, above the TV screen. During play it produces a variety of sounds that add to the game excitement.

1.2 SUMMARY OF GAME PLAY

A player's objective in "Flyball" is the same as that in a real baseball game—to score more runs than the opponent does. Just as in a real game every ball pitched will turn out to be a strike, a ball, or a hit. Also, an inning lasts until three outs have been made by each side. In Flyball an out is made after three strike pitches are thrown, or else when the

pitcher intercepts a ball in play and then tags a runner heading for a base or for home plate. The players take turns at pitching and batting.

The play sequence starts out with the player at the left being the pitcher. After three outs the left player becomes the batter and the right player becomes the pitcher. By means of an owner/operator option the game can be structured to last for one inning, or else for two innings. Counts of the runs scored by each player are continuously displayed near the top of the TV screen; inning number, and current counts of balls, strikes and outs are displayed near the bottom of the screen.

The video action takes place on a ballfield diamond in the center part of the screen. At the beginning of a play sequence only two ballplayer figures appear: the batter behind home plate and the pitcher in the center of the diamond. The player batting moves his or her joystick lever to change the position of the bat; pushing the joystick forward causes the bat to swing forward and pulling the joystick back causes it to swing back. The player pitching operates his or her joystick to control two types of motion—ball motion, and after a hit the motion of the pitcher figure running about the playfield in pursuit of the ball.

The player batting has the choice of letting a ball go by or of swinging at it. When no swing was made, the game decides whether the pitch was a strike (inside the "strike zone") or else a ball. But if the batter swings and misses, that pitch is counted as a strike. If four pitches have been counted as balls, that batter gets a walk and a new batter will appear. The pitcher can "throw" a new pitch as soon as the previous ball has gone off the screen.

If the batter succeeds in hitting the ball, it reverses direction and goes out onto the diamond. Also the batter figure immediately changes to a running figure that heads toward first base. The player pitching must now manipulate the joystick so that the pitcher moves to intercept the ball and then to tag a runner. Meanwhile the runner automatically continues toward the base. If the base is reached

before the pitcher has caught the ball, then the runner continues on toward the next base. The runner will stop at a base only if the pitcher has already caught the ball or else a player has depressed the "hold runner" push button. Each runner reaching home plate causes a run to be registered, and then the runner disappears.

When the pitcher succeeds in tagging a runner, that runner disappears from the screen and an out is registered. The pitcher figure returns to the pitching position at the center of the diamond after all runners have been put out or else are safe on base. New batters keep appearing until the last out has been made in the last inning, at which point the play sequence ends. The final scores remain showing however.

While pitching, the players quickly discover that more vigorous movement of the joystick lever will cause the pitcher figure to throw faster balls, and that right after the pitch a movement of the joystick

to the right or left adds a corresponding right or left curve to the ball's flight path toward the batter. Likewise while batting the players discover that vigorous movement of the joystick produces faster bat swings and corresponding harder hits, and that direction of ball motion resulting from a hit can be chosen by careful timing of the bat swing. Batters also discover that bunts can be made merely by holding the bat stationary and letting the ball collide with it.

Three types of sounds are produced by the speaker during a play sequence. A crowd roar sound, with three levels of amplitude, is heard continuously during play. A "crack" sound is heard when the bat hits the ball, and a footsteps sound when a runner is advancing toward a base.

Section III of this manual gives additional details about game play and describes the owner/operator options.

II. SPECIFICATIONS

2.1 GENERAL

- Cabinet Dimensions:** Height 63 $\frac{1}{2}$ in., Width 25 $\frac{1}{2}$ in., Depth 29 $\frac{1}{2}$ in.
- TV Monitor:** Motorola Model XM501, black and white, with 23-inch screen.
- Coin Mechanisms:** Two identical mechanisms (connected in parallel); accept quarters only.
- Cash Box:** Removable; located behind locked access door to coin mechanism assembly.
- Power Cord:** Approximately 6 ft. long, extending from rear of cabinet and having grounded three-prong plug for conventional wall outlets.

2.2 ELECTRICAL

- Power Requirement:** Uses conventional wall outlet providing 60-cycle AC (60 Hz, single phase) at 110 volts; rated at about 100 watts.
- Fusing:** All fuses located inside cabinet; TV monitor has two 1-amp fuses and remainder of game is protected by a 1-amp slow-blow fuse.

Power Interrupt Switch:

This is a safety switch located inside the cabinet. It causes the AC power to the game to be interrupted whenever the rear panel access door is unlocked and opened.

2.3 ENVIRONMENTAL

- Operating and Storage Temperature Range:** from 32°F to 120°F (*Ambient Temperature*)
- Relative Humidity:** From 0% to 80% *without condensation*

2.4 OWNER/OPERATOR OPTIONS FOR STRUCTURING OF PLAY

- Cost of a Game Play: can be set for 25¢, 50¢ or \$1 (four coins)
- Game Length: can be set for 1 or for 2 innings
NOTE: A speaker volume adjustment is also provided.

2.5 ACCESSORIES AVAILABLE ON SEPARATE ORDER

- Video Probe:** order from Atari
- Universal Test Fixture:** order from Atari, catalog no. TF-101



III. THEORY OF OPERATION

3.1 FUNCTIONAL DESCRIPTION OF GAME

The block diagram in Figure 3-1 shows the major functional parts of the Flyball game and their interconnections. Note that the game printed circuit board sends a composite video signal to the TV monitor and a separate audio signal to the speaker.

3.2 GENERAL INFORMATION

The general information about the Flyball game given here provides a background for understanding the Installation Instructions in Section IV of this manual, and the description of game operation in paragraphs 3.3 and 3.4.

3.2.1 Energizing the Game:

The game does not have an external "Power On" switch. Instead it is energized as soon as the power cord is plugged into an active AC wall outlet. This outlet must provide the AC power listed in the Specifications (Section II of this manual).

3.2.2 TV Monitor:

The game's TV monitor is a self-contained transistorized television monitor supplied to Atari by Motorola. Because the composite video signal sent to the monitor by the game control circuitry differs in certain important respects from the signal derived from commercial TV broadcasts, the picture appearing on the screen is unlike that of a home TV set and the monitor does not produce any sound.

3.2.3 Picture on TV Screen:

The game's composite video signal is constructed to produce only two video levels (white and black), instead of the more or less continuous shades of gray seen on a home TV screen. Figure 3-2 shows a typical picture that would appear on the screen during play and identifies the objects in the picture.

The ball and the pitcher are allowed to move about on the playfield. But the bat swing motion always occurs at home plate, and the runners are only allowed to run forwards (counterclockwise) along the baselines. The remaining objects are held in stationary positions on the TV screen.

3.3 GAME SEQUENCE

3.3.1 Operating Modes:

During use the "Flyball" game can be described as operating in either of two modes, attract or play. Plugging the power cord into an active AC outlet energizes the game and it starts out in the attract mode. The game remains in the attract mode until a player deposits a coin and the coin clears the coin mechanism, at which point a signal derived from the coin mechanism causes the game to go into the play mode. The game remains in the play mode until the third out is made during the last half of the last inning. At that point the game reverts back to the attract mode.

For certain servicing purposes only the game can be made to operate in a third "diagnostic" mode. Subparagraph 6.3.3 in Section VI of this manual gives guidelines about when to put the game in this mode.

3.3.2 Attract Mode:

Figure 3-3 shows a typical picture that would appear on the TV screen after completion of a play sequence in the play mode. After initial application of AC power the picture in the attract mode may vary somewhat from that shown in the figure.

The words *GAME OVER* near the top of the screen will be blinking on and off at a rapid rate. The words in the entire top line of writing will be changed approximately every one or two seconds, with the following sequence being repeated over and over again:

"PITCHER CHASE BALL TAG RUNNER"
then "MOVE CONTROL ↑ TO PITCH OR BAT"
then "MOVE CONTROL ↗ TO MOVE PITCHER"
and then "25 CENTS PER GAME." The words about game cost will correspond to the cost choice set up by an owner/operator option, so that the specific words appearing will be one of the following: "25 CENTS PER GAME," or "50 CENTS PER GAME," or "4 COINS PER GAME."

In the attract mode one runner figure will be rapidly advancing around all the bases, and past home plate, over and over again. The pitcher figure

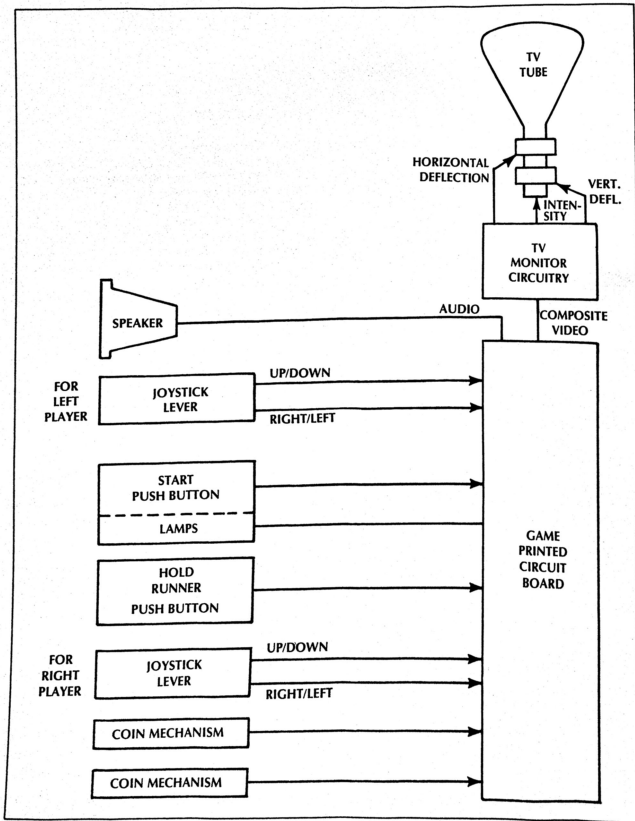

Figure 3-1 Functional Block Diagram of Flyball Game

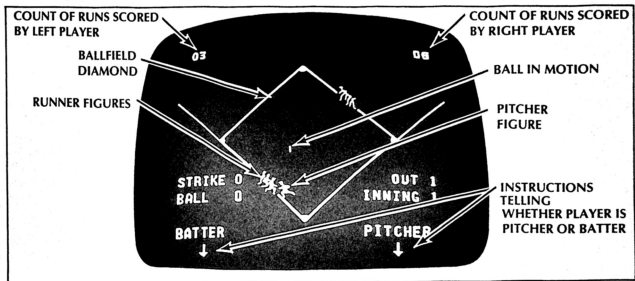

Figure 3-2 Typical Picture During Play

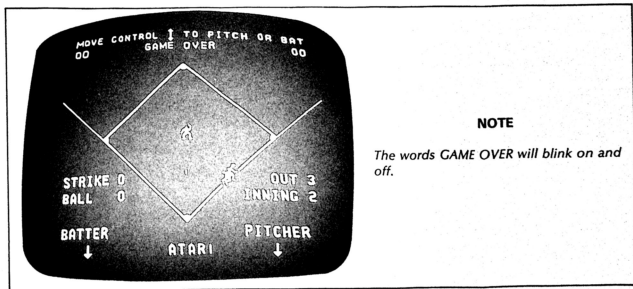

Figure 3-3 Typical Picture During Attract Mode

will remain motionless in the center of the playfield diamond. Neither a batter figure nor a ball will appear. No runs are registered during the attract mode; instead the scores left over from the most recent play sequence will remain showing throughout the attract mode. None of the other numerical information (counts of strikes, balls, outs, and inning number) will change either.

3.3.3 Play Mode:

Players cause the game to change over from the attract mode to the play mode by depositing coins in

the game. After a coin has been accepted, the game will respond by changing the second line on the picture, as follows. The words GAME OVER will disappear and a "coins accepted" announcement will appear (such as ONE COIN ACCEPTED, TWO COINS ACCEPTED, etc.). When the number of coins deposited reaches the amount needed for a game play, the game will respond by lighting up the START pushbutton. To continue the play sequence, a player must now depress the START pushbutton. At this point in the play sequence the game will also recognize a player's depressing of the unlighted

HOLD RUNNER pushbutton in the same way that it recognizes START.

After the player has depressed either pushbutton, the game now will proceed as follows:

(a) The alphanumeric lines at the top of the screen will disappear, and only score numerals will remain. Both scores will be reset to zero.

(b) Any runners that had been showing previously will be removed so that the only player figures left will be the pitcher and the batter.

(c) The count of strikes, balls, and outs will all be reset to zero, and the inning will be reset to "1."

(d) The word PITCHER with an arrow below it, in the lower left corner of the TV screen, will blink on and off for approximately five seconds. Also, the word BATTER with an arrow below it, in the lower right corner, will also blink on and off for approximately five seconds.

(e) Both player joystick controls will now be enabled.

The left player can now operate that joystick to pitch balls, and the right player can now operate that joystick to swing the bat and hit balls. When a hit is made, the left player can manipulate that joystick so that the pitcher figure will chase after the ball. The right player can now only affect the game sequence by depressing the HOLD RUNNER pushbutton. This portion of the game sequence is completed when either the pitcher has tagged out the runner, or the runner has stopped on base. Then the pitcher throws a new ball, and the batter attempts to hit that. The game sequence continues until three outs have been made.

At that point in the play sequence the word PITCHER, with an arrow below it, appears in the lower right corner; and the word BATTER appears in the lower left corner. Now the two players have changed so that the left player is now the batter and the right player is now the pitcher. The play sequence continues with this arrangement until another three outs have been made. If the game length owner/operator option has been set for one inning, the game sequence now ends. However, if set up for two innings, the preceding sequence is repeated a second time.

The player who is the batter will find out that movement of the joystick lever will cause the bat to move into one of eight bat positions. Approximately half of these positions are ahead of home plate, and approximately half are behind home plate. Whenever a runner crosses home plate, one run is added to that player's score and also, the word RUN appears at the top of the screen for a few seconds. However, if the batter manages to hit the ball hard enough and the ball goes past the pitcher, then this is considered a home run. The words HOME RUN will appear at the top of the screen. These words will blink on and off for a few seconds and one run will be added to the player's score.

During this part of the play sequence, the game will recognize the depressing of TWO PLAYER START in the same manner that it recognizes the depressing of the HOLD RUNNER pushbutton. This feature of the game makes it convenient so that each player has a separate pushbutton to operate during a play sequence, although the markings on the buttons are not identical. Also, each time that a third out has been made, the word OUT in the lower right portion of the screen will blink on and off for a few seconds. When a home run has been made, the speed at which the runner travels around the bases will be noticeably faster than the speed of a runner after some hit other than a home run has been made.

The game's four types of sounds are produced only during the play mode. The crowd roar sound has three levels of amplitude. The lowest level is heard continuously throughout the play mode. The intermediate level of amplitude is heard when a hit has been made, and the highest level of amplitude is heard after a home run has been made. When the ball hits the bat the "crack" sound is heard.

Foul ball hits are not allowed, and only one ball can appear on the TV screen at any one time.

3.3.4 Owner/Operator Options:

The Flyball game has two options which the owner/operator can adjust at the game site in order to structure the play sequence, that is to change some of the game rules or the duration of play. Paragraph 4.3 in Section IV of this manual gives detailed instructions for adjusting these options. The game also has a speaker volume adjustment (refer to paragraph 5.3 in Section V).

(a) *Game Cost Option.* This option consists of two switches on a miniature assembly comprised of

side-by-side switches. Each switch can be set either in an "on" or an "off" position. One combination of settings will fix the cost at 25¢ per game play; a second combination will fix it at 50¢, and a third will fix it at \$1 (four coins).

(b) *Game Length Option.* This option consists of another switch on the same switch assembly. Setting this switch in one position fixes the game length at 1 inning, and setting it in the other position fixes it at 2 innings.

3.4 DETAILED TECHNICAL DESCRIPTION OF OPERATION

3.4.1 General Comments:

This subsection gives a technical description of the game's electronic circuitry. Drawing number 005629 is a nine-sheet schematic diagram of the circuitry on the printed circuit board, and drawing number A005629 is the PCB assembly drawing showing the locations of the components called out on the schematic. The position of each integrated circuit device is identified by a column letter designation (A through R), and by a row number designation (1 through 9). Drawing number 005816 is a schematic of the harness wiring inside the game cabinet. These drawings and a schematic diagram of the TV monitor's circuitry are included in Section VII of this manual.

On the PCB schematic the symbol *P* (appearing at various inputs to logic gates and other integrated circuits) indicates a connection to +5 volts through a pull-up resistor.

In the subparagraphs that follow, the portions of the circuitry being described can be located on the PCB schematic by finding the intersection of the zone letters (A, B, C or D) and the zone numbers (1 through 8). For example, the designation *Sheet 1, Zone A 8* refers to the extreme lower left corner of sheet 1 of the schematic.

Sheet 9 of the PCB schematic is a detailed block diagram of the board's circuitry. The main data and control interconnections between the blocks, as well as those coming from the front panel joysticks and switches, are also shown on the diagram.

This subsection of the manual gives technical descriptions of game circuitry regarded as field-repairable. Correction in the field of problems

traced to certain portions of the circuitry on the game's PCB may require replacement of the entire board.

3.4.2 Sheet 6 of Schematic:

(a) *Clock Generator (Zone D7 & D8).* The output of a 12-MHz crystal-controlled oscillator drives flip-flop L1 to produce the H CLOCK signal at L1 pin 5. This signal provides the basic clock synchronization for the game circuitry and also drives the horizontal countdown chain.

(b) *Horizontal and Vertical Countdown Chains (Remainder of Sheet).* Flip-flop L1 and counters R1 and P1 form a countdown chain that counts down the frequency of the H CLOCK signal to produce the 1H through 256H timing signals. Certain of these signals are applied to flip-flop N2 to produce the H SYNC signal whose timing forms the basis for the horizontal synchronization information sent to the TV monitor on the composite video signal.

The H SYNC signal is also applied to counters A3 and B3 and flip-flop D2 and N2, which form the vertical countdown chain. These counters produce the 1V through 128V timing signals. Also flip-flop N2 produces the \bar{V} RESET signal that changes state once per picture frame. Counter R8 (in Zone B2) produces a signal whose timing forms the basis for the vertical synchronization information sent to the TV monitor.

(c) *Video Summing (Zone C2).* The junction of resistors R44 through R48 forms the video summing point for the various signals that are combined on the composite video sent to the TV monitor. The timing of the PLAYFIELD signal, coupled through R45, determines when a picture is produced on the TV screen. The synchronization information is coupled through R46. The ball portion of the TV picture is coupled through R47, the pitcher figure through R48, and the remaining playfield objects through R44.

3.4.3 Sheet 1 of Schematic:

(a) *Joystick Interface (Zones B, C, D 7 and 8).* The eight potentiometers on the PCB are adjusted at the factory and none of the settings should be disturbed after the game arrives at the game site. (Only potentiometers on the joystick assemblies should be adjusted at the game site.) A wire from each joystick potentiometer connects to the negative input of a type-LM339 amplifier.

(b) *Ramp Generator (Zones A 6, 7, 8).* Flip-flop P7 drives a 2N3643 transistor that has a large

resistor-capacitor load connected to its collector terminal. The timing of the flip-flop's output causes a ramp-shaped waveform to appear at the positive inputs to the LM339 amplifiers in location L8. Five ramps are developed during one picture frame time on the TV monitor.

(c) *Pot-Ramp Comparators (Zones B6, C6, D6).*

The amplifiers in L8 form four position-sensing circuits, as follows: vertical (up/down) and horizontal (right/left) circuits for the right player's joystick position, and a similar pair for the left player's joystick position. The output of each LM339 amplifier will be either low or high. The output changes from low to high at the time that the ramp waveform crosses the voltage that is applied from the joysticks (at L8 pins 6, 4, 10 and 8). Note that each of the four comparators can change state independently of one another.

(d) *Pot Interrupt Disables (Zones B5, C5, D5)*

and *Pot Interrupt (Zone C4).* At the beginning of a ramp waveform the gates L7 will be open, so that the comparator outputs can pass through the gates and on to gate K6. If any of the signals applied to gate K6 go low, then the output at K6 pin 6 will go high. This signal, along with the ramp timing signal and H SYNC, is applied to gate P2. With this arrangement the IRQ (interrupt request) signal, at gate P2 pin 12, can only be produced during H SYNC time once every line on the TV. Therefore the first comparator to indicate that the ramp has crossed the voltage will be the one to cause the first interrupt to be produced.

(e) *Interrupt Event Time Data (Zones D4 and*

B4). When the game's control circuitry receives the interrupt request signal, a READS POTS command is sent to pin 1 of the type-8T98 tri-state buffer in location L6. When a low is applied at pin 1, all four of the gates in the 8T98 will be energized. The D0 through D3 outputs are then interrogated to determine which comparator has caused the interrupt.

After this has been done, the control circuitry shuts off the READS POTS signal and a READ VERT (read vertical) command is produced. A low is applied to pins 1 and 15 of the type-8T97 buffer device in location A4. Now the six timing signals 1V through 32V are passed through and on to the D0 through D5 output lines. This timing allows the control circuitry to determine when the interrupt occurred.

As the last step in the interrogation sequence the control circuitry must close gate L7 to block off the appropriate comparator(s). This is done by means of the D0 through D3 commands which cause the flip-flops in location K7 to be set, thus shutting off gates L7 (at pins 2, or 5, or 12, or 9). All the flip-flops are reset before the start of each new ramp waveform.

3.4.4 Sheet 2 of Schematic:

(a) *X-Y Coordinate Generators (left half of schematic).* For the ball, the counters K4 and D4 produce the horizontal component of its position on the screen, and J4 and E4 produce the vertical component. Likewise, for the pitcher figure, counters L4 and C4 produce the horizontal component of the figure's position, and H4 and F4 produce the vertical component. These are four sets of divide-by-256 counters that are preset at a particular time during the play sequence. The preset information is contained on the eight signal lines $\overline{D0}$ through $\overline{D7}$, and the presetting is done during vertical blanking time.

The ball contribution to the picture is contained in the BALL VIDEO signal produced at P8 pin 12. The outputs from the counters for the pitcher figure connect to two PROM devices in locations E2 and F2, and to a type-74175 device in location F3.

(b) *Graphics Select and Video Shift Register (right half of schematic).* The type-74175 device in location F3 determines which of the pitcher pictures will be selected out of the PROMs. The PROMs have 16 pictures, all for the pitcher only. The type-75166 devices in locations E1 and H1 form a serial shift register. The parallel input data to this shift register come from the PROMs. The shift register is bidirectional; it can shift left or shift right. The output from the shift register produces the pitcher contribution to the TV picture, at P8 pin 10.

3.4.5 Sheet 3 of Schematic:

(a) *Playfield RAMs (left half of sheet).* The type-2111 RAMs in locations L3, P3, M3 and N3 produce graphics address data that are applied to the playfield ROM or ROMs shown on sheet 4. The address data applied to the RAMs, in turn, are produced by the two type-74157 devices in locations R3 and K3. The RAMs produce addresses for 512 picture "blocks" (each 8 dots wide by 16 dots high) on the TV screen. But the actual graphics (letters, numerals, baselines, runner figures, etc.), however, are stored in the playfield ROM.

(b) *Video Shift Register (right half of sheet).* The type-74194 devices form a bidirectional shift register. The outputs from the playfield ROM or ROMs are applied in parallel to this shift register. The playfield objects picture information in serialized form is contained in the VIDEO OUT signal, produced at N7 pin 8. The PLAYFIELD signal contains the timing that determines when the picture will appear on the TV screen.

3.4.6 Sheet 4 of Schematic:

Playfield ROMs (left half of sheet) and Playfield ROM (right half of sheet). The game's printed circuit board is designed so that either four ROM devices—in locations J2, L2, K2 and M2—or else one type-4600 ROM device can be installed on the board. (A board will be built with one choice or the other, but not both choices simultaneously.) The operation of the game is the same under either choice. The ROM circuit function has already been covered in subparagraph 3.4.5.

3.4.7 Sheet 5 of Schematic:

(a) *Buffers For On-Board Mode Switches and Front Panel Switches (Zone C & D 6, 7, 8).* The switches contained in the structuring switch assembly mounted on the game's PCB, the switches on the front panel that are operated by the players, and the two coin mechanism switches all connect to the type-8T97 buffer devices in locations K8 and H8. These buffers produce the buffered data, the signals $\overline{D0}$ through $\overline{D7}$.

(b) *Game Address Decode (right half of sheet).* The type-7442 devices in locations H3 and M6 are used as decoders that produce the various control signals needed during a play sequence. The type-9334 device in location F7 is used as an addressable latch that produces the control signals used in the sound generation circuitry. This latch also produces a signal that turns on an SCR to provide the lamp current when the TWO PLAYER START push button is to be backlit.

3.4.8 Sheet 7 of Schematic:

(a) *Random Noise Generator (Zones D7 through 8).* The type-74164 devices in locations B7 and C7, and flip-flop D7 and gates E7, form a digital noise generator. Clocking for this circuit is provided by

the 128V and $\overline{256H}$ timing signals produced by the countdown chains (see (b) of subparagraph 3.4.2). The noise output signal is produced at D7 pin 8.

(b) *Bat Sound (Zones C7 & C8).* The type-556 device in location E8 forms a circuit that produces two short, gated square waves. These signals are slightly offset in frequency, and interact together during the sound summing to give a sharp cracking sound when the ball hits the bat. The circuit is triggered by the BAT HIT ON/OFF signal.

(c) *Crowd Roar (Zone C5).* The type-LM741 amplifier in location D8 is connected as a bandpass filter. It takes the output signal from the random noise generator and makes it seem more like a crowd roar sound.

(d) *Footstep Generator (Zone B4).* The amplifier in location C8 acts as a current-controlled volume control circuit. Its output gets louder as the resistance from C8 pin 2 to ground is lowered. The circuit is driven by the FOOTSTEP OFF/ON signal, so that footstep sounds are produced whenever any runner is advancing toward a base or home plate.

(e) *Crowd Volume Control (Zones C3 & C4).* The amplifier in location A8 also acts a current-controlled volume control. The three control signals CROWD VERY LOUD, CROWD OFF/ON and CROWD SOFT LOUD vary the resistance from A8 pin 2 to ground, so that the three amplitude levels of the crowd roar sound are heard during a play sequence.

(f) *Master Volume Control and Output Amplifier (Zones A through D 1 & 2).* Potentiometer R95 is connected to the sound summing point and provides the speaker volume adjustment described in paragraph 5.3 in Section V of this manual. The output amplifier drives the speaker mounted in the upper portion of the cabinet, above the TV monitor.

(g) *Power Supply (Zones A, B6 through 8).* The amplifier is connected in a full-wave diode rectifier circuit that provides the +5 volt supply for the board. A second pair of diodes is connected in a full-wave circuit that produces an unregulated +18 volts for the speaker amplifier circuit.

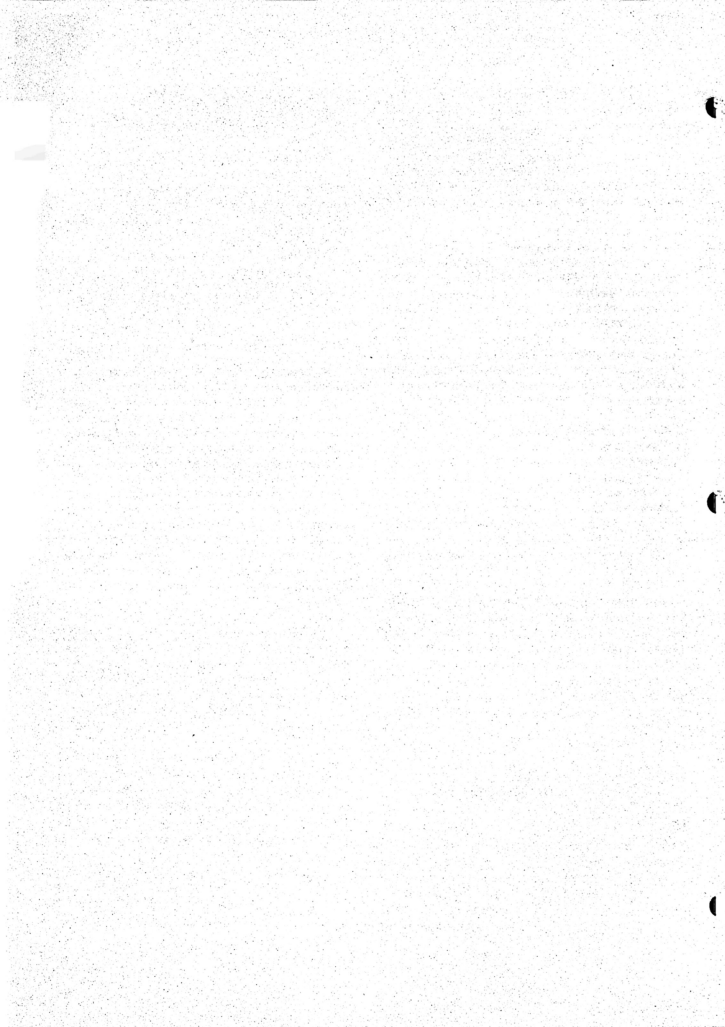

IV. INSTALLATION INSTRUCTIONS

4.1 UNPACKING INSTRUCTIONS

4.1.1 Examination for Shipping Damage:

Before shipment from the factory, components and sub-assemblies of each game are carefully checked for proper operation. However, during shipment some adjustments may have changed or parts may have been damaged. Upon initial removal of the game from the shipping container, first examine the exterior of the cabinet. Then open the rear (or side) access panel and also examine the interior. Any shipping damage such as a dented, cracked or broken cabinet, sub-assemblies broken loose, etc., should be reported immediately to the shipper and to Atari, Inc.

4.1.2 Mechanical Inspection:

After determining that the game has been received in good condition, carefully inspect the interior parts and verify the following:

- (a) All slip-on and plug-in connectors are firmly seated (particularly the PCB edge connector)
- (b) The fuses are all seated in their holders
- (c) No loose foreign objects are present (especially metal objects which could cause electrical short circuits)
- (d) No harness wires have become disconnected or pulled loose.

Be sure *all* major assemblies have been checked: game PCB, the transformer and other components on the electronics tray assembly, the two coin mechanisms, the speaker, the player controls (joystick levers and push button switches), and the TV monitor chassis.

Do not go on to the remaining paragraphs in this section until the above mechanical inspection has been thoroughly performed.

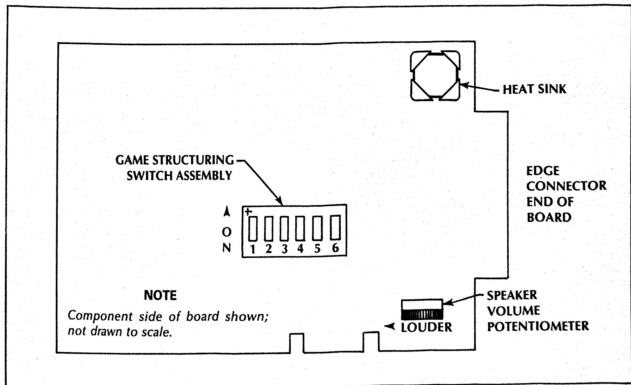

Figure 4-1 Appropriate Locations of Game Structuring Switches and Speaker Volume Adjustment

4.2 ENERGIZING THE GAME

4.2.1 Application of AC Power:

Close and lock the access panel, making sure that it is completely shut at the bottom, and remove the key from the lock. Then plug the power cord into an AC outlet providing the AC power listed in the Specifications (Section II of this manual). The wall outlet must accept a three-prong plug and the receptacle must be connected to a good earth ground.

After the power cord has been plugged in, the proper response from the game is that a picture appears on the TV screen.

If there is no response at all from the game, unplug the power cord and check the AC wall outlet. A simple, safe way to check for presence of AC power at the wall outlet is to plug in an appliance known to be working properly—such as a table lamp, radio, or an electric clock. If the wall outlet passes the check, then presume that the trouble is with the game and refer to Section VI of this manual.

CAUTION

No troubleshooting steps should be attempted inside the cabinet by anyone not familiar with safety measures and repair procedures on electrical equipment.

Do not go on to the remaining paragraphs in this section until the proper response described above has been observed.

4.2.2 Check on Operation of Interlock Switch:

The interlock switch is a safety switch mounted inside the game cabinet near the top edge of the rear access panel. At the factory this switch is mechanically adjusted so that it will automatically transfer to its "off" position (switch contacts "open") whenever the panel is opened. When the interlock switch is in its "off" position, the AC power leading to the game's power supply is interrupted. When the panel is closed, the interrupt switch is adjusted to be in the "on" position (switch contacts "closed") and AC power is allowed to reach the game's power supply, meaning that the game can operate.

After application of AC power per paragraph 4.2.1 above, correct operation of the interlock switch can be checked as follows: unlock and slowly

open the panel. The correct response is that by the time the edge of the panel has moved about 2 to 3 inches away from the cabinet the TV screen should go dark, verifying that the interlock switch has automatically transferred to "off." While opening the panel do not insert fingers inside the cabinet and do not allow foreign objects to fall inside. If the TV screen continues to be lighted up even after the panel has been opened, immediately close and lock it and unplug the power cord from the wall outlet. Then refer to Section VI of this manual to replace and/or adjust the interlock switch.

Do not go on to the remaining paragraphs in this section until the operation of all interlock switches has been checked and found to be correct.

4.3 GAME STRUCTURING

Before putting the game into operation at the game site, the game structuring should be defined by the owner/operator. The term "game structuring" refers to the game rules and the duration of the play sequence. Paragraph 3.3.4 of Section III in this manual covers the owner/operator options featured in this game and describes how they affect the game structuring.

In the Flyball game all structuring is accomplished by selecting positions on a miniature switch assembly mounted on the game printed circuit board. To do this the board has to be removed from its metal enclosure and then the switch positions have to be adjusted by hand.

Before performing any adjustment, the game should be de-energized or not operating. Further, it is also recommended that the power cord be unplugged beforehand.

Unlock and open the rear panel access door; doing this should cause the interlock switch to de-energize the game, as described in paragraph 4.2.2. If the switch fails to de-energize the game, immediately close and lock the door, unplug the power cord, and refer to Section VI of this manual to adjust and/or replace the switch.

While being careful to avoid touching any parts of the body against the TV chassis components or other wiring connections inside the cabinet, find the metal enclosure that houses the game PCB. Then unplug the edge connector to the RF board on the front of the enclosure, carefully noting how the connector plugs in. (It must be reconnected *in*

exactly the same way after the switch positions have been changed.) Next remove the screws holding the RF board onto the enclosure and unplug the RF board from the game PCB. Now the game PCB has been freed so that it can be slid out of the enclosure far enough to allow access to the switches. Examine the surface of the board and identify the switch assembly shown in Figure 4-1. (Its exact location is shown on the PCB assembly drawing, drawing number A005629 in Section VII of this manual, with the designation SW1; the volume adjustment potentiometer is designated R95.) Each of the various two-position switches on the switch assembly can be independently set to either an "on" or "off" position. Table 4-1 lists correct settings for the three choices of game cost, and for game lengths of 1 inning and 2 innings.

- Switch #1 }
 Switch #2 } Not used (can be in any position)
- Switch #3 Game Length is 1 inning when in "off" position; 2 innings when in "on" position.

	Game Cost		
	25¢/game	50¢/game	4 coins/game
Switch #4	on	on	off
Switch #5	on	off	off

- Switch #6 Not used; must be left in "off" position for normal game play.

Table 4-1 Settings on Game Structuring Switch Assembly

After the desired structuring has been set up, slide the game PCB back into its enclosure and plug the RF board back on to the game PCB. Replace the RF board on the front of the enclosure and secure it in place. Then replug the edge connector back onto the RF board, making sure that it is reconnected in the way originally found.

After performing these adjustments, close and lock the side panel, and energize the game.

4.4 FUNCTIONAL CHECK OF GAME OPERATION

The following procedure provides a simple check that can be quickly performed at the game site

and that does not require external test equipment. If at any point during this procedure the game's response is found to be other than that called for herein, assume the game is not operating correctly and refer to Section VI of this manual. If responses are as described here then assume that major parts of the game are operating correctly. First perform the adjustments described in paragraph 4.3, Game Structuring, and then energize the game (paragraph 4.2). Just after application of power a picture should appear on the TV screen and the game should be operating in the attract mode as per subparagraph 3.3.2.

NOTE

Sometimes upon initial application of power (or, more rarely, later on during play) the TV monitor may produce a "scrambled" picture. This irregularity happens if the game's internal circuitry has not initialized itself. Although normally taken care of automatically, it is possible that severe noise spikes on the AC power line could upset the self-initialization. Generally a "scrambled" picture can be corrected by de-energizing the game and then re-energizing it, one or more times. Do this either by unplugging the power plug from the wall outlet and reconnecting it, or else by opening and then closing the cabinet's rear access panel so that the interlock safety switch is exercised.

4.4.1 Check of Attract Mode:

No sounds should be produced during the attract mode. The picture should resemble the one shown in Figure 3-3.

As described in subparagraph 3.3.2, the words *GAME OVER* should be blinking on and off, the words in the entire top line of writing should change every one or two seconds, and one runner figure should be advancing around the bases, over and over again. The backlit TWO PLAYER START push button should be dark. The joystick lever and push button player controls should all be disabled.

4.4.2 Check of Play Mode:

After correct game operation in the attract mode has been verified, deposit a coin in one of the coin mechanisms. As soon as the coin has been accepted, the game should respond by changing over

to the attract mode, as described in subparagraph 3.3.3. If the game cost is set up for 25¢ per game, then the deposit of this first coin will cause the TWO PLAYER START push button to light up. But if the game is set up for 50¢ per game, then a second coin must be deposited. And if set up for four coins per game, then three more coins must be deposited before the start button will light. No sounds should yet be produced by the game speaker.

Depress the backlighted start button. Doing this should cause the picture on the TV screen to change. As described in subparagraph 3.3.3, both scores should be reset to zero, the number "1" should appear after the word INNING, and the count of strikes, balls and outs should all be zero. Also the word PITCHER with an arrow beneath it should be blinking on and off in the lower left corner of the screen, as should the word BATTER with an arrow beneath it in the lower right corner.

Now operate the right-hand joystick and confirm that the batter figure moves the bat through 8 separate positions. The rear-most position of the bat should correspond to the rear-most position of the joystick lever, and the forward-most position of the bat to the forward-most position of the joystick lever. Next operate the left-hand joystick to cause the pitcher figure to throw a ball. After the ball is in motion, operate the left joystick lever to cause the ball to curve to the right and to the left. Next operate the batter joystick so that the batter hits the ball. Confirm that the batter changes to a runner figure that advances toward first base. Next operate the left joystick to confirm that the pitcher figure can be made to chase the ball, catch the ball, and tag a runner so that an out will be registered.

After the first out has been registered, the word BATTER with an arrow beneath it should appear in the lower left corner and be blinking on and off, and the word PITCHER with an arrow beneath it in the lower right corner, also blinking on and off. Continue operating the two joystick levers so that a hit will be made and runs will be scored for each of the players, and confirm that these runs are registered at the top of the TV screen. Continue until all the outs have been made so that the game sequence ends. While doing this also confirm that all the game sounds are being produced, as described in subparagraph 3.3.3.

After the third out in the last inning has been made, the game should change over from the play mode to the attract mode. When in attract no sounds should be produced and the scores should still be showing from the just-completed play sequence.

As the final part of the check deposit one or more coins in the other coin mechanism and confirm that the game changes over to play mode. Go through another play sequence and confirm that depressing the "hold runner" push button will start the sequence and also will cause the runner to hold on base during play. Confirm that depressing the start button will also cause the runner to hold on base.

If at any time during the above check it was found that either joystick lever will not cause the pitcher to throw a ball, or if either joystick lever will not produce at least 7 separate bat positions, then refer to subparagraph 6.3.3 in Section VI of this manual.

This completes the functional check.

V. MAINTENANCE AND ADJUSTMENTS

5.1 ROUTINE MAINTENANCE

Due to its solid-state electronic circuitry, this Atari game should require very little maintenance and only occasional adjustment.

5.1.1 Cleaning:

Game cabinets and glass may be cleaned with any non-abrasive household cleaner. If desired, special coin machine cleaners which leave no residue can be obtained from distributors.

5.1.2 Lubrication:

About once every three months lightly spray the rejector linkage portion of the coin acceptor inside each coin mechanism. Use WD-40® or similar lubricant, and avoid spraying the entire coin acceptor. Potentiometer shafts must never be lubricated in any way.

5.2 ADJUSTMENTS ON TV MONITOR

The TV monitor need be adjusted *only* when the picture is distorted, or if the contrast or brightness seem out of adjustment.

NOTE

The TV monitor is accessible only from inside the game cabinet and these adjustments have to be done while the game is energized. Therefore only persons familiar with safety measures and repair procedures on electrical equipment should perform them.

The monitor's adjustments function like those of a conventional commercial television set, except that the volume adjustment has no effect. Instead the game produces its sound in a speaker separate from the TV monitor. Figure 5-1 shows the location

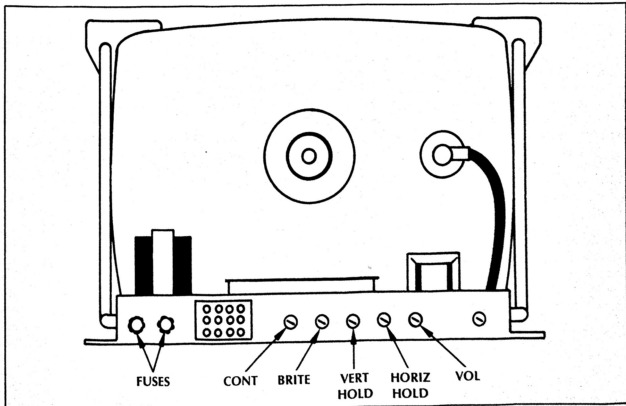

Figure 5-1 Location of Adjustments on TV Chassis

of the adjustments on the rear of the chassis. When making the adjustments follow these general guidelines:

BRITE (Brightness)—Perform this adjustment before the contrast. Adjust so that the white lines covering the screen just barely disappear, when the brightness is turned up.

CONT (Contrast)—Adjust so that the images are as bright as possible against the dark background without being blurred.

HORIZ HOLD (Horizontal Hold)—Adjust if the picture is slightly off-center horizontally, if the images appear warped, or if the picture is broken up into a series of diagonal lines. Adjust for a stable, centered picture.

VERT HOLD (Vertical Hold)—This needs adjustment only if the picture appears to be rolling up or down the screen. Adjust for a stable, centered picture.

5.3 ADJUSTMENT OF SPEAKER VOLUME

The speaker electronic drive circuit is provided with a potentiometer that controls the volume of sounds produced during play. This potentiometer is mounted on a printed circuit board inside the game cabinet and it can be manually adjusted to give the volume level desired. The following procedure tells how to make this adjustment.

Unlock and remove the access panel at the rear of the cabinet. Doing this should cause the interlock switch to de-energize the game, as described in subparagraph 4.2.2. If the switch fails to de-energize the game, immediately replace and lock the panel, unplug the power cord, and refer to Section VI of this manual to adjust and/or replace the switch.

While being careful to avoid touching any parts of the body against the TV chassis components or other wiring connections inside the cabinet, find the metal enclosure that houses the game PCB. Unplug the edge connector that connects the wire harness to the RF board mounted on the front of the metal enclosure. Note how this connector plugs in; it must be reconnected in *exactly* the same way after the volume adjustment has been made. Next remove the screws that hold the RF board onto the front of the metal enclosure, and then unplug the RF board from the game PCB. The game PCB is now free to move out of the enclosure.

Slide the PCB on its guides until it is partway out and the volume adjustment potentiometer is accessible. Figure 4-1 shows its approximate location.

(Its exact location is shown as R95 on drawing number A005629 in Section VII of this manual.) To increase speaker volume, move the stud on top of the potentiometer body in the direction shown by the arrow in Figure 4-1. To decrease speaker volume, move the stud in the opposite direction.

After making the adjustment, push the game PCB all the way back into the enclosure, replug the RF board onto the game PCB, and then secure it in place on the front of the enclosure. Next replug the wire harness edge connector back onto the RF board, *making sure* that it is reconnected in the way originally found. Then replace the cabinet panel and energize the game.

5.4 ADJUSTMENT OF POTENTIOMETERS ON JOYSTICK ASSEMBLIES

This paragraph gives a procedure for adjustment of the arms on a pair of potentiometers located on each joystick assembly. This adjustment can be done at the game site. At the factory, all potentiometers are initially adjusted and normally will not require any readjustment afterwards. However, if certain trouble symptoms develop, such as those described in subparagraph 6.3.3 in Section VI of this manual, performing this procedure may correct the troubles. If not, shop servicing of the game will be required. The procedure is divided up into four sets of steps that must be performed in the sequence listed.

PRELIMINARY STEPS

- 1) Unlock and open the coin door. DE-ENERGIZE the game.
- 2) Reach inside the cabinet and locate the four bolts that attach the player control panel to the cabinet. Loosen and remove all four nuts from these bolts.
- 3) Carefully lift off the control panel so that the joystick assemblies are visible, and allow the panel to hang by its wires. Take care not to damage the wiring connections or the components mounted on the panel. Now ENERGIZE the game again.
- 4) Locate the "Pot-Set" switch that is mounted just inside the coin door opening, near the door hinge. (When the control panel is removed, this switch can be seen on the front panel, to the left of the coin door, facing the cabinet.) Pull the stud, which protrudes from the "Pot-Set" switch, all the way out. Doing this will put the game in the "diagnostic" mode of operation.
- 5) Now four sets of 2-digit numbers that change with joystick motion will appear along the top of

the TV screen (see Figure 5-2). These numbers can range from 00 through 77, but certain numbers will be skipped. Specifically, there are no 8s or 9s. **DO NOT WORRY, BECAUSE THIS IS NORMAL.**

VERTICAL ADJUSTMENT STEPS

After the preliminary steps have been performed, these steps should be carried out on the left joystick and then repeated for the right joystick. These steps are a check on the joystick's vertical range. During each step observe the pair of numbers on the screen that correspond to that joystick's movement, as indicated in Figure 5-2.

- 6) When the joystick lever is pushed forward, the minimum number on the screen should be 03 or smaller. This number should be reached at the very end of control motion. That is, after the minimum number is reached, no more control motion should be remaining. If the foregoing is not true, then during game play the pitcher may not be able to pitch his ball.
- 7) When the joystick lever is pulled all the way back, the maximum number on the screen should be reached. This number should be between 63 and 73. If the foregoing is not true, then during play the pitcher will not be able to run down-screen as fast as he should.
- 8) When the joystick lever is left in the spring-center, neutral position, the number showing on the screen should be in the high 30s or low 40s. If the foregoing is not true, then during play the pitcher will run faster in one direction than in the other.
- 9) If misadjustments are found during steps 6, 7, and 8 above, then the appropriate joystick potentiometer must be adjusted. Figure 5-3 shows the general locations of the adjustment points, and Figure 5-4 shows a detail view of the adjusting arm. Break the melted plastic heat seal with a razor blade or other tool. Then slowly move the adjusting arm and set it so that you can achieve the correct test results, as described in steps 6, 7, and 8. Glue the pots down with glue such as RTV or model airplane cement when finished.

During adjustment, the most important thing to accomplish is to set the minimum achievable number equal to or less than 3, without leftover control motion, as described in step 6. If the numbers called out in steps 7 and 8 also cannot be achieved, the game is probably playable but should be shop aligned at a later date.

However, if game play is unacceptable, then shop realignment is required.

- 10) After the adjustments have been made, retighten the screws on the control pots; tighten just enough to allow finger adjustment of the control-adjusting arm.

HORIZONTAL ADJUSTMENT STEPS

After the vertical adjustment steps have been performed, a similar set of horizontal steps should be carried out on each joystick. During these steps the side-to-side (left to right) motion of the joystick levers will be checked.

- 11) When the joystick lever is moved to the left, the minimum number on the screen should be 10 or smaller. This number should occur at the very left end of joystick motion. That is, after the minimum number is reached, no lever motion should be remaining. When the joystick lever is moved to the right, the maximum number should be 70 or larger, at the very right end of motion. If either of the foregoing is not true, then during play the pitcher's horizontal ball-chasing speed will not be accurately set, or left and right players may run differently.
- 12) When the lever is in the spring-centered, neutral position, the number should be in the high 30s or low 40s. If the foregoing is not true, then during play it may be difficult to make straight-line pitches.
- 13) If misadjustments are found during steps 11 and 12, then the appropriate joystick potentiometer must be adjusted. Break the melted plastic heat seal with a razor blade or other tool. Then again move the adjusting arm to achieve the correct test results as described in steps 11 and 12. Glue the pots down with glue such as RTV or model airplane cement when finished.

During adjustment, the most important thing is to spring-center the control and get the numbers close to 37 or 40 on the TV screen, as described in Step 12. If the numbers called out in Step 11 cannot also be achieved, the game is probably playable, but should be aligned at a later date. If game play is unacceptable, then shop realignment is required.

CONCLUDING STEPS

After all the above steps have been carried out, the satisfactory game operation during a normal play sequence should be verified before replacing the control panel.

- 14) Push in the stud that projects from the "Pot-Set" switch; doing this should change the game over from "Diagnostic" mode to attract mode. Then deposit coins to change the game over to play mode.
- 15) Depress the start button and then operate both joysticks to confirm that the correct responses are obtained from the pitcher, ball and the batter. Be sure that each joystick is checked both when it controls the batter and also when it controls the pitcher and ball. If one or more responses are incorrect go back and repeat the appropriate steps from 4 through 13 at least once. Then repeat steps 14 and 15. Now DE-ENERGIZE the game.
- 16) Put the control panel back into its normal position. Put the four nuts back on their respective bolts and tighten them, so that the panel is held firmly in place.
- 17) Make sure the stud on the "Pot-Set" switch is pushed in, so that the game will be taken out of "diagnostic" mode.
- 18) Close and lock the coin door. Then turn on the power again. This completes all steps in the procedure.

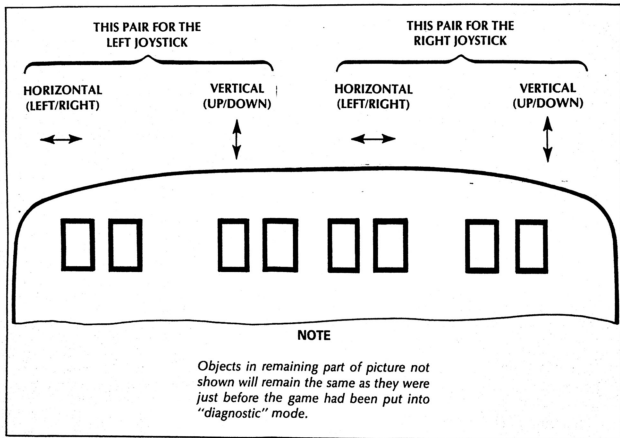

Figure 5-2 Picture on TV Screen During Diagnostic Mode

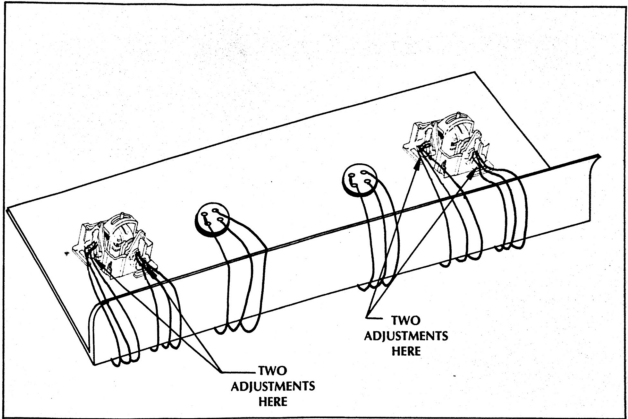

Figure 5-3 Locations of Adjustments on Rear Side of Control Panel

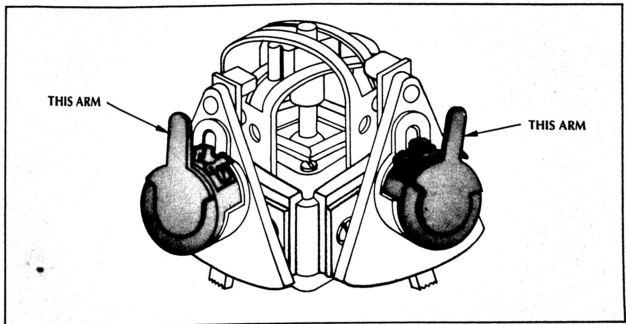
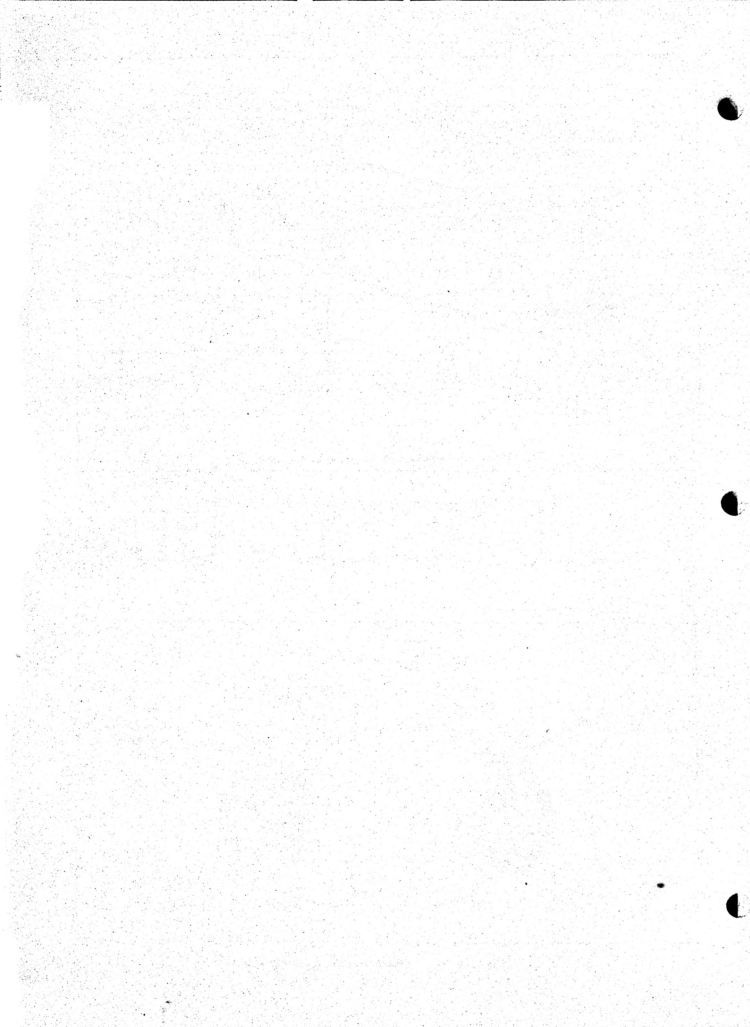

Figure 5-4 Detail View of Joystick Assembly



VI. TROUBLESHOOTING AND REPAIR

6.1 GENERAL PROCEDURE

NOTE

This section describes troubleshooting procedures in detail sufficient for a person with moderate technical ability to understand. However, for those interested in gaining more information on video game technology, especially the electronics, we recommend reading the Video Game Operator's Handbook, manual no. TM-043. This book is available from Atari, Inc., attn. Customer Service Dept., 2175 Martin Avenue, Santa Clara, CA 95050 for \$5.00 each, or from your distributor.

6.1.1 Identifying the Trouble Area:

The first troubleshooting step should be to note all observable trouble symptoms. Examples of symptoms are: depositing a coin produces no game response, no sound coming out of the speaker at any time, no picture on the TV screen. At the same time also not the game features that still work. A systematic way of checking game operation is to perform the functional check given in Section IV of this manual. Carefully train your eye to pick up all clues; by doing this an experienced troubleshooter can often spot the cause of a trouble even before he opens the cabinet.

Keeping these observations in mind, use the understanding of game operation gained from the theory of operation (Section III) and the schematic drawings (Section VII). Next narrow down the suspected cause of the trouble to a specific area or areas of the game: coin mechanism, TV monitor, harness or front panel components (switches, joysticks, lamps, speaker), electronics tray, printed circuit board or power cord. Be careful not to overlook possible trouble areas that may seem too obvious: a power cord plug that has worked loose from the wall outlet and is no longer fully seated in the receptacle, or a rear panel access door that is not fully closed (thus causing the interrupt switch to block the AC power path to the game).

6.1.2 Locating the Trouble Cause:

Once a problem has been narrowed down to one or more areas, the next step is to perform various tests and measurements to isolate a specific cause of the trouble. Remember that sometimes a very complicated problem, such as erratic game operation, can be traced to a simple cause—the printed circuit board not being fully seated in its edge connector. Start with the most suspect area and trace backwards from the point where the trouble is first observable, using a process of elimination to eventually locate the faulty component, connection, etc. For example, if no sound is audible during game play, first check for a signal at the speaker leads. If no signal is present there, go back through the wiring harness connections to the printed circuit board. If there is still no signal, then systematically check back through the various components of the sound generation circuit.

Substitution of parts is a legitimate and easy way to isolate the cause. For instance, if the PCB is the suspected trouble area, remove it and substitute a known-to-be-good PCB. Then check for correct game operation. Similarly, to check the TV monitor, connect the game to a known-to-be-good monitor. The harness can often be checked by substitution also. Substitute both a known-to-be-good PCB and TV monitor. If the trouble still persists, the harness must be at fault.

While locating the trouble cause, use the technical descriptions in Section III as guides for correct circuit-level operation, and the schematic drawings of Section VII as roadmaps for tracing signal flow paths.

The test equipment for use in troubleshooting is discussed in paragraph 6.2.

6.1.3 Correcting the Trouble Cause:

In practice, the steps required to correct troubles can range from simple adjustments (fully seating the PCB in its edge connector, changing the setting on a potentiometer, adjusting the picture controls on the TV monitor) to repair of loose connections and replacement of defective parts. Extreme care should be exercised when removing integrated

circuit devices and discrete components. Use a 40-watt soldering iron with a small tip designed especially for IC work. To remove an IC device, follow this procedure:

Clip all leads and lift the IC package out, leaving two rows of leads. Then remove leads individually with a soldering iron and needle-nose pliers. Finally, evacuate the holes with a solder sucker. Afterwards clean the area thoroughly, using an approved PCB cleaning solution to remove any traces of flux and dirt. Alcohol will do in a pinch, if necessary.

Insert the new IC device using an IC insertion tool, making sure that the reference notch is oriented correctly and that the device's leads are not bent during insertion into the board. Afterwards, be sure to solder each lead on *both* sides of the PCB, using as little solder as possible. After soldering, clean the area thoroughly to remove the flux.

Observe the same removal and insertion procedures when replacing discrete components. Trim the leads as close as possible and be sure to orient diodes and capacitors correctly.

6.1.4 Verifying Correct Game Operation:

After locating and correcting the cause of a trouble, re-energize the game and perform a final check on correct game operation. Doing this will verify that your troubleshooting was correct. If the game operation is still not correct, go back and double-check your work. Make sure that any replaced components were installed correctly. If this was done properly, then start the troubleshooting steps over again. Keep in mind that there may be more than one trouble at a time, and that correcting one trouble can sometimes bring previously undetectable troubles to light.

This verification is especially important when the original trouble had been intermittent, that is, was not happening all the time.

6.2 TEST EQUIPMENT

Electronic troubleshooting of a video game essentially consists of checking for the presence of various signals and of examining their condition. A signal can be thought of as acting like a "messenger" that carries instructions from one unit or circuit to another. Many different types of signals are produced in a video game, and for this reason several unusual and perhaps unfamiliar types of test

instruments are used during troubleshooting. Each instrument has its own set of advantages and disadvantages for examining a given type of signal, and both the depth of the intended troubleshooting capability and budget will determine what instruments will be needed. Some instruments are basic and essential, no matter what size of service facility, while other optional instruments are desirable because they make troubleshooting easier and quicker.

6.2.1 Basic Test Equipment:

(a) *The Video Probe.* This is a simple but invaluable instrument having two leads—a test-clip lead and a test-probe lead. During troubleshooting of video signals the test-clip lead is left connected to the game side of the video coupling capacitor. On the Flyball game this point is the junction of resistors R44 through R48 on the PCB. When the test-probe lead is then connected to any video developmental signal, that signal will be coupled to the video signal going to the TV monitor and a video probe picture will appear on the TV screen. The shape and other characteristics of this picture will give information about the signal being probed. The video probe is suited for troubleshooting synchronization and image signals, but will not be useful for extremely fast signals (such as the clock) or for very slow analog or digital signals.

A video probe can be constructed in a few minutes from these common electrical components: a length of 20 AWG (American Wire Gauge) rubber-coated wire, a 4.7K-ohm, ¼-watt carbon resistor, and two test leads. For the leads, use a single Mouser test clip (Mouser # 131C301 or 302) attached to one end of the wire, and a test prod containing the resistor on the other.

To assemble the video probe, proceed as follows: Remove the cap from the test clip and strip 3/16 inch off each end of the wire. Solder one end to the post in the test clip, thread the other end through the hole in the cap, and snap on the cap. Next unscrew the plastic body of the test prod from the point and trim both leads of the resistor to a 3/16-inch length. Solder one resistor lead to the inside of the point. Thread the other end of the wire through the hole in the body and solder it to the other resistor lead; screw the body back onto the point.

(b) *The Logic Probe.* This is a test instrument designed for fast verification of digital IC outputs. It

is small, convenient to carry, easy to read, and relatively inexpensive. The logic probe derives its power from the system under test; it has two power leads, one for connection to ground and the other to +5 volts DC. When the logic probe's tip is held against a digital signal point, three colored lamps in the tip will indicate the signal's condition or state, as follows:

- The red lamp lit indicates a high or logic level 1 (for TTL components, this is +2.4 to +5 volts)
- The white lamp lit indicates a low or logic level 0 (for TTL components, this is 0 to +0.8 volt)
- The blue lamp lit indicates that the signal is changing states
- No lamps lit indicate the grey region between 0 and 1 (for TTL this is between +0.8 and +2.4 volts)

A circuit shorted to ground will illuminate the white lamp and an open circuit will illuminate the red lamp.

The logic probe is readily available from electronic supply sources; a commercial model found satisfactory is the Kurz-Kasch model LP 520.

(c) *The Logic Pulser.* This test instrument is similar in size and shape to the logic probe, and it also derives its power from the system under test. When the logic pulser's tip is held against a digital signal point, the source and sink capabilities of the pulser override any IC output and the point is driven to the opposite logic level. If the point that the logic pulser is held against is low, pressing the switch on the side of the pulser will introduce a high pulse. Conversely, pulsing a high line will pull that line low momentarily.

During troubleshooting the logic pulser allows stimulation of in-circuit ICs with a shaped digital pulse. For example, a certain feature of the game may not be working and you suspect that a circuit is not receiving the necessary signal. Use the pulser to imitate that signal: if the circuit begins working, you have proved that the signal was in fact missing and you can begin tracking it down. This technique is very similar to jumping coils in electromechanical games such as pinball machines.

In addition to the regular "pulse" button, there is another switch mounted on the logic pulser. When this switch is set in the "rep" mode, the instrument pulses the digital signal point at a 5-Hz rate or 5 times per second. This extremely low rate is

slow enough to allow watching events initiated by the pulser. Counter outputs, for example, are more easily observed when the counter is pulsed or clocked at this rate.

The logic pulser is also readily available from electronic supply sources; a commercial model found satisfactory is the Kurz-Kasch model HL 583.

(d) *Oscilloscope.* The most versatile test instrument, and also the most expensive, is the oscilloscope. The high-speed TTL integrated circuits used in video games produce fast-rise-time signals. The oscilloscope should have a 50-MHz bandwidth, dual trace and dual time base capability. These latter features allow examination of both input and output signals simultaneously, so that precise timing relationships can be checked. The oscilloscope should also have provision for internal or external sync.

Of the newer, solid-state oscilloscopes, a satisfactory model is the Tektronix 465.

(e) *VOM or Volt-Ohmmeter.* This common measuring instrument is extremely useful in video game troubleshooting. It can be used to check line voltage, transformer secondary windings, continuity, resistance, power supply voltages, and to some extent used for measurements in the analog circuitry.

One commercial model found satisfactory is the Simpson 260.

6.2.2 Optional Test Equipment:

(a) *The Logic Comparator.* This test instrument's main benefit is that it can be used to check the functioning of an integrated circuit device while the device is still in place on the printed circuit board. The logic comparator performs the check by comparing the suspect ICs functioning with that of an identical-type reference IC mounted in the instrument itself. Suppose that the functioning of a type-74193 device on the PCB is suspected to be defective. First insert a program card with a known-to-be-good 74193 into the logic comparator, and then clip the comparator test leads onto the leads of the suspect device. If there are any logic state differences between the reference IC and the suspect IC under test, then an LED on the logic comparator will light up to indicate which output is not functioning correctly. Once a defective IC has been located, it should be replaced.

Logic comparators are readily available from electronic supply sources.

(b) *Atari Universal Test Fixture*. In situations where a large number of video games are being serviced, investment in the Universal Test Fixture will be justified. This item of test equipment forms a test station for troubleshooting printed circuit boards after they have been removed from the game cabinet. The Universal Test Fixture has a full set of controls for operating the game and also has its own TV monitor. The game's PCB is plugged into an edge connector mounted on the side of the Fixture; with this arrangement the PCB is positioned in a convenient way for connecting probes and other test instruments.

A program card inserted into a receptacle in the top of Fixture takes the place of the game's interconnect wires. The program card thus sets up the Fixture for each particular game; the game's name is clearly printed on the program card itself.

With the Universal Test Fixture the method of troubleshooting via substitution of known-to-be-good parts is made fast and convenient. For example, suppose that the TV picture in a game is completely broken up and you want to determine whether the game or monitor is causing the problem. Remove the PCB and plug it into the Fixture's edge connector, and also insert the correct program card for that game. If the picture on the Fixture's monitor is correct, then you know that the problem lies in the game's monitor.

6.3 SPECIFIC TROUBLESHOOTING INFORMATION

The following subparagraphs give additional troubleshooting information about certain areas of the Flyball game.

6.3.1 Coin Mechanism:

If a player inserts a coin and the game does not respond, first check the coin mechanism. If pressing the coin rejector button forces the rejector mechanism to return the coin, then examine the coin to make sure that it is genuine. If it is, then use a set of your own test coins (which should include both very new and very old, worn coins) to determine whether or not the player's coin is undersize or underweight. If your test coins are also returned, this indicates that servicing of the coin acceptor portion of the coin mechanism is called for. Generally the cause of this particular problem is an improperly adjusted magnet gate.

Inside the coin mechanism a magnet is used to test the metallic composition of the coin. Highly magnetic coins, such as those made of steel or iron, will be retained by the magnet and can be returned by actuating the wiper operating lever. Coins having comparatively high magnetic properties will be slowed down by the magnet, and will drop off the end of the rail short of the "accept" entrance and be returned. Coins having little or no magnetic properties, such as brass or zinc coins, will pass through the magnetic field so fast that they will overshoot the "accept" entrance and be returned.

A magnetic gate adjusted with too large a gap may pass both genuine and counterfeit coins. An adjustment with too small a gap can lead to rejection of some or even all coins. Over a period of time, the screw that adjusts the magnet gate has a tendency to work loose, resulting in a gradual narrowing of the gate. At first, only the thickest (i.e., newest) coins are rejected. As time passes, more and more coins are rejected until finally player complaints lead to the calling of the game repairman.

If pressing the coin rejector button does not cause the coin to be returned, and if the game still does not respond, then check the coin mechanism to see if the coin is jammed inside.

If you are certain that the coin is genuine, and that the coin passes through the coin mechanism and into the cash box, then the lack of game response is probably due to some kind of electrical trouble. Check for signals at the electrical contacts of the coin mechanism before moving on to the harness and other parts of the circuitry.

6.3.2 TV Monitor:

The TV monitor is a self-contained unit housed in its own chassis. A trouble's cause may be narrowed down to the monitor—either by the substitution method using a known-to-be-good monitor, or by verifying presence of AC power to the monitor power supply and presence of the correct composite video signal. The entire monitor can then be removed from the game cabinet. Doing this facilitates troubleshooting steps, because all monitor components will then be accessible.

A schematic diagram of the monitor circuitry is included in Section VII of this manual. After disconnecting and removing the monitor from the game, standard TV troubleshooting techniques are adequate for locating causes of trouble. Additional

servicing information is available from the monitor manufacturer (Motorola).

6.3.3 Joystick-Related Trouble Symptoms:

This subparagraph describes certain trouble symptoms that may be traced to the joysticks and their potentiometers. Some of these troubles can be corrected at the game site by performing the potentiometer adjustments described in Paragraph 5.4 in Section V of this manual. Correction of the remaining troubles will require shop servicing.

- (a) **Symptom:** When one or both joysticks are operated the pitcher figure cannot be made to pitch a ball, i.e., the ball never leaves the pitcher's hands. Or else it takes several tries to pitch properly.

Trouble Cause: Probably the vertical motion pots on the joystick assemblies will not reach the minimum, as described in the adjustment procedure of Paragraph 5.4.

- (b) **Symptom:** Pitcher can be made to chase ball, but seems to run faster in one direction than the other.

Trouble Cause: Joystick pots probably not centered. Adjust centering, but be sure that the low numbers mentioned in Paragraph 5.4 are still obtainable.

- (c) **Symptom:** Pitcher will not run as fast as he should, or left and right player speeds are very different.

Trouble Cause: Joystick pots probably not centered, or may require shop realignment.

- (d) **Symptom:** Batter has fewer than 7 bat positions on screen.

Trouble Cause: Probably misadjustment of joystick pots. May require shop realignment.

- (e) **Symptom:** Game does not play; four pairs of numerals appear at top of screen and they vary with joystick position.

Trouble Cause: Game has been put in the "diagnostic" mode. To correct this trouble make sure that Switch #6 of the miniature switch assembly on the printed circuit board is put in the "off" position, and that the "Pot-Set" switch is in its "contacts open" position with stud pushed all the way in. (Paragraph 5.4 describes the location of the "Pot-Set" switch.)

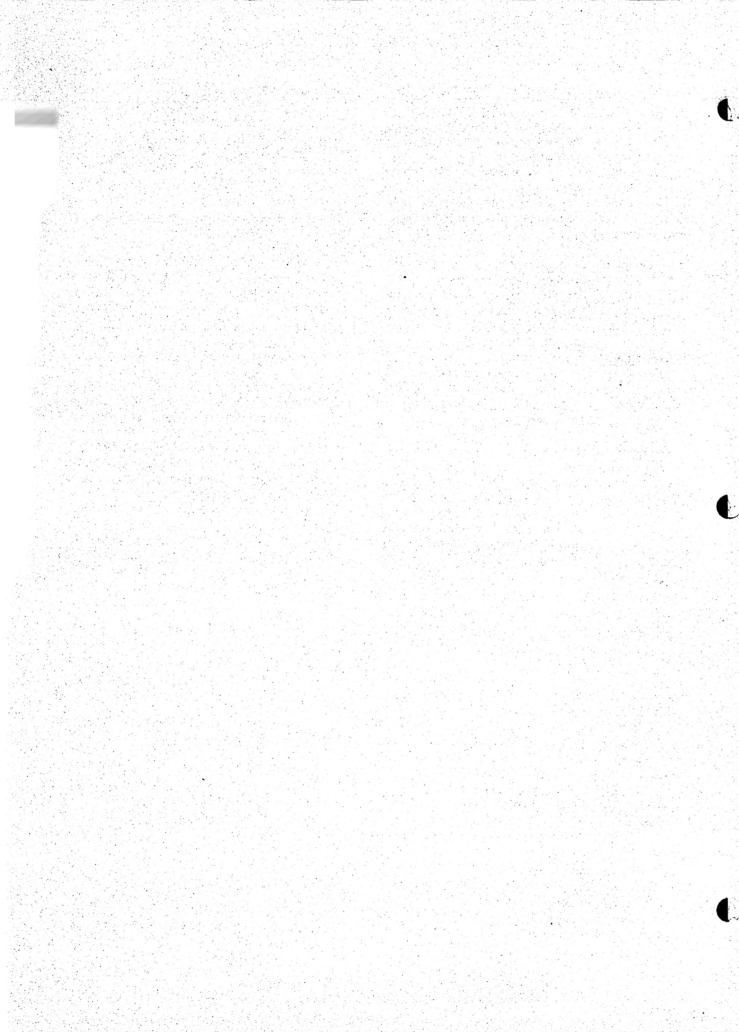

VII. SCHEMATICS, DRAWINGS AND PARTS LISTS

Number	Title
A005292	Parts List and Drawing Top Assembly
005824	Drawing Screened Control Panel
A005429	Parts List and Drawing Control Panel Assembly
A005820-01	Parts List and Drawing Electronics Tray Assembly
005816	Schematic Harness
A005629	Schematic, Parts List and Drawing Printed Circuit Board
(none)	Schematic Motorola Model XM501/701 TV Monitor



PARTS LIST SPECIFICATION

Page 1 of 1

Drawn Regan

Checked

Mech. Eng

Proj. Eng.

Elec. Eng

REV.
D

Rev.	Description	Date	Apprv.	Rev.	Description	Date	Apprv.
A	5000 101	6-10-76					
B	Rev per ECN 2766	6-22-76					
C	Rev per ECN 2802	6-30-76					
D	Rev per ECN 2909	7-28-76					

Item	Part Number	Qty.	DESCRIPTION
1	A005291-02	1	Cabinet Assembly, (Silkscreened)
2	A005430	1	Display Assembly
3	A005427	1	Monitor Support Assembly
4	A005820-01	1	Electronics Tray Assembly
5	A005912-01	1	R.F. Shield Assembly
6	A005429	1	Control Panel Assembly
7	A003637-08	1	Coin Door Assembly
8	005378-01	1	Shield Monitor (Silkscreened)
8A	005699-01	Ref	Shield, Monitor
9	A 005380	1	Bezel, Cardboard
10	71-2114	1	Lock, Mech., Barrel Cartridge
11	68-001	2	Interlock Switch, A.C. Power
12	000268	2	Interlock Switch Bracket
13	005419	1	Speaker Grill (8" Speaker)
14	005422	1	Shield, Display Light (Silkscreened)
14A	005843-01	Ref	(Breakout) Light Box Plex Panel
15	003053	2	Upper Plex Retainer, (Anti-Aircraft)
16	75-99090006	6	Weldnut, #10-32
17	73-77002	4	Pop Rivet, 3/16" O.D. x 3/4" Lg.
18	75-5524B	4	Carriage Bolt, #4" - 20 x 1-1/4" Lg. Black
19	75-015S	4	Washer, Flat, #4"
20	75-045	4	Washer, Split-Lock, #4"
21	75-915S	4	Nut, Hex, #4 - 20
22	72-6012	4	Screw, S.M., Pan Hd., Phil., #10 x 3/4" Lg.
23	75-010S	6	Washer, Flat, #10
24	75-040	10	Washer, Split-Lock, #10
25	75-911S	6	Nut, Hex Hd., #10-24
26	75-5120B	6	Carriage Bolt, #10-24 x 1-1/4" Lg. Black
27	72-6812	4	Screw, S.M., Pan Hd., Phil., #8 x 3/4" Lg.
28	72-6608	5	Screw, S.M., Pan Hd., Phil., #6 x 1/2" Lg.
29	82-8014B	6	Button Head Screw, #10-32 x 7/8" Lg.
30	005817	Ref	Harness Schematic
31	A005629	1	P.C. Board (Flyball)
32	A005490-01*	1	R.F. Board (Flyball)
33	72-6608	10	Screw, S.M., Pan Hd., #6 x .50" Lg.
34	A005490-02	1	R.F. Board (Flyball)
35	006305	1	Printed Poly Bag

*For use with 005630 Rev. A only.

NOTE: THE FOLLOWING INFORMATION IS FOR THE MANUFACTURER'S USE ONLY. IT IS THE RESPONSIBILITY OF THE MANUFACTURER TO OBTAIN ALL NECESSARY INFORMATION FROM THE DRAWING AND TO FOLLOW THE SPECIFICATIONS AND INSTRUCTIONS THEREON. THE MANUFACTURER SHALL BE RESPONSIBLE FOR THE PROPER FABRICATION AND FINISH OF THE PART.

REV	DATE	DESCRIPTION	BY	APPROVED
A		PRODUCTION REL		6716

DRAWING NO. 005824 SHEET 1 OF 2

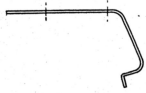
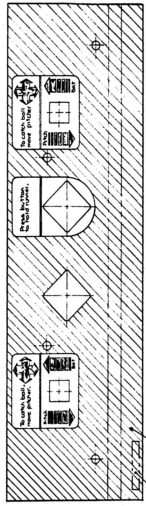

3 FARSIDE

OUTSTANDING ECNs

3 PERMANENT-MARK PART NO. & LATEST REVISION LETTER USING 10 MIN. HIGH CHARACTERS. LOCATE APPROX. AS SHOWN.

2 SHADED AREAS TO BE BLACK.

1. DOUBLE ANODIZE PER ATARI ARTWORK N8 005824 SHT. 2

 ATARI INCORPORATED 1450 GARDEN, CULVER CITY, CALIFORNIA 90230	
DO NOT SCALE DRAWING DRAWN BY: S 25-76 DATE:	CHECKED:
NUMBER OF COPIES OF THIS DRAWING: ASSESSED: 100 RELEASED: 100	PROJECT NUMBER:
MATERIAL: MAKE FROM 005360-01	REG. NUMBER:
FORM: SEE NOTE	REG. NUMBER:
10059429 FLYBALL SHEET 1 OF 2	DRAWING NO. 005824 SHEET 1 OF 2

NOTES: UNLESS OTHERWISE SPECIFIED



PARTS LIST SPECIFICATION		Page 1 of 1
Drawn	Regan	
Checked		Mech. Eng.
Proj. Eng.		Elec. Eng.
		REV. D

Rev.	Description	Date	Apprv.	Rev.	Description	Date	Apprv.
A	PROD REL	6-11-76					
B	Rev per ECN 2874						
C	Rev per ECN 2882						
D	Rev per ECN 2905	7-27-76					

Item	Part Number	Qty.	DESCRIPTION
1	005824	1	Control Panel, w/Graphics
1A	005360-01	Ref	Panel, Control
2	A004304-14	1	Switch Assembly - Blank
3	A004304-10	1	Double Light Switch Assembly - 2 Player
4	A006293-01	2	Control Stick Assy
5	A005818-01	1	Control Panel Harness
6	75-3205 S	8	Machine Screw, Flat Head, Phil. #2-56 x 5/16 Lg.

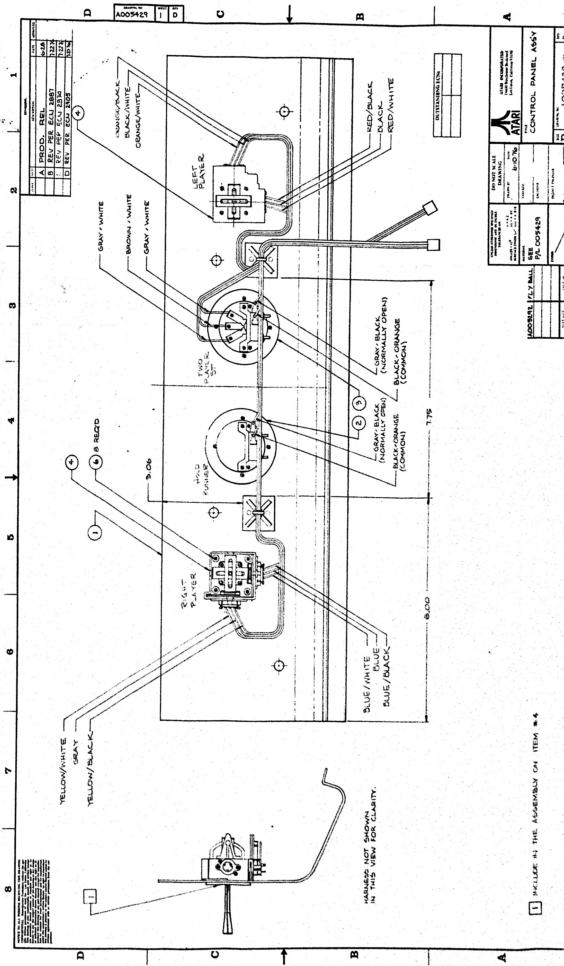

ALL DIMENSIONS ARE IN INCHES UNLESS OTHERWISE SPECIFIED.
 DIMENSIONS TO CENTER UNLESS OTHERWISE SPECIFIED.
 DIMENSIONS TO FACE UNLESS OTHERWISE SPECIFIED.
 DIMENSIONS TO CENTER UNLESS OTHERWISE SPECIFIED.
 DIMENSIONS TO FACE UNLESS OTHERWISE SPECIFIED.

REV. 10/76
 A009421 I D

ATARI
 HOME ENTERTAINMENT
 DIVISION

CONTROL PANEL ASSY

DATE: 10/76
 PART NO: A009421
 REV: 1
 AUTH: [Signature]

DATE: 10/76
 PART NO: A009421
 REV: 1
 AUTH: [Signature]

DATE: 10/76
 PART NO: A009421
 REV: 1
 AUTH: [Signature]

1 WIRE COLORS NOT SHOWN IN THIS VIEW FOR CLARITY.

PARTS LIST SPECIFICATION

Page 1 of 1

Drawn	
Checked	Mech. Eng
Proj. Eng.	Elec. Eng
	REV. A



Rev.	Description	Date	Apprv.	Rev.	Description	Date	Apprv.
A	PROD REF	6/17/76					

Item	Part Number	Qty.	DESCRIPTION
1	005289-01	1	Electronics Tray
2	A005817-01	1	Main Harness
3	A005817-02	1	Interlock Switch Harness
4	001551-01	1	Transformer, 001551
5	005497-03	1	Cover Transformer
6	000871-01	1	Label
7	46-201202	1	Fuse, 2 AMP
8	79-3201	1	Fuse Holder
9	41-2001	1	Filter, 2 AMP Power Line
10	A004576-03	1	AC Power Cord, 8 Ft Assy
11	A001921-01	A/R	Shorting Block, 95V
12	A001921-02	"	" " " 110V
13	A001921-03	"	" " " 220V H
14	A001921-04	"	" " " 220V L
15	72-6608	1	Screw, SM, Pan Hd Phil #6 x 1/4 Lg
16	72-6612	7	" " " " #6 x 3/4 Lg
17	72-6812	7	" " " " #8 x 3/4 Lg
18	A005817-03	1	Flyball Jumper Assy

4

3

2

1

NOTICE TO ALL PERSONS RECEIVING THIS DRAWING
 CONFIDENTIAL: This drawing contains information that is the property of Atari, Inc. and is to be used only for the purpose intended. It is not to be distributed, copied, or otherwise made available to the public or to any other person without the written consent of Atari, Inc. This drawing is the property of Atari, Inc. and is to be returned to Atari, Inc. upon completion of the work for which it was prepared. It is not to be used for any other purpose without the written consent of Atari, Inc.

DATE	APPROVED
1/7/78	
DATE	REVISION
DATE	DESCRIPTION
DATE	DESCRIPTION

D

D

DRAWING NO.	SHEET	REV
A005820	1/1	A

C

C

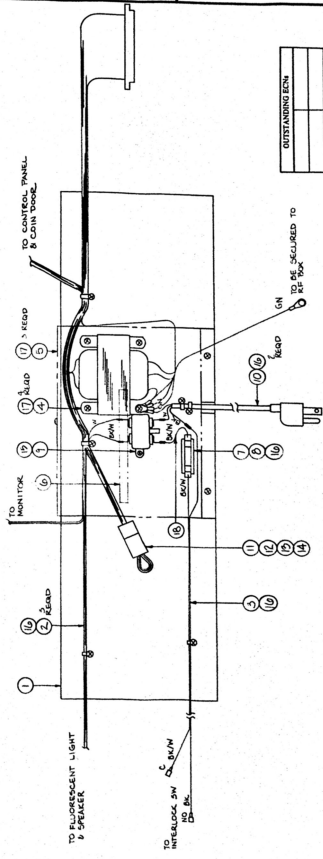

B

B

OUTSTANDING ECN

PRIMARY

SECONDARY

CURRENT VERSION -01



ATARI INCORPORATED
 1300 AVENUE OF THE STARS
 BERKELEY, CALIFORNIA 94705
 (415) 841-0800

DO NOT SCREW
 -DRAWING
 DATE: 1/7/78

ATARI
 ATARI INCORPORATED
 1300 AVENUE OF THE STARS
 BERKELEY, CALIFORNIA 94705
 (415) 841-0800

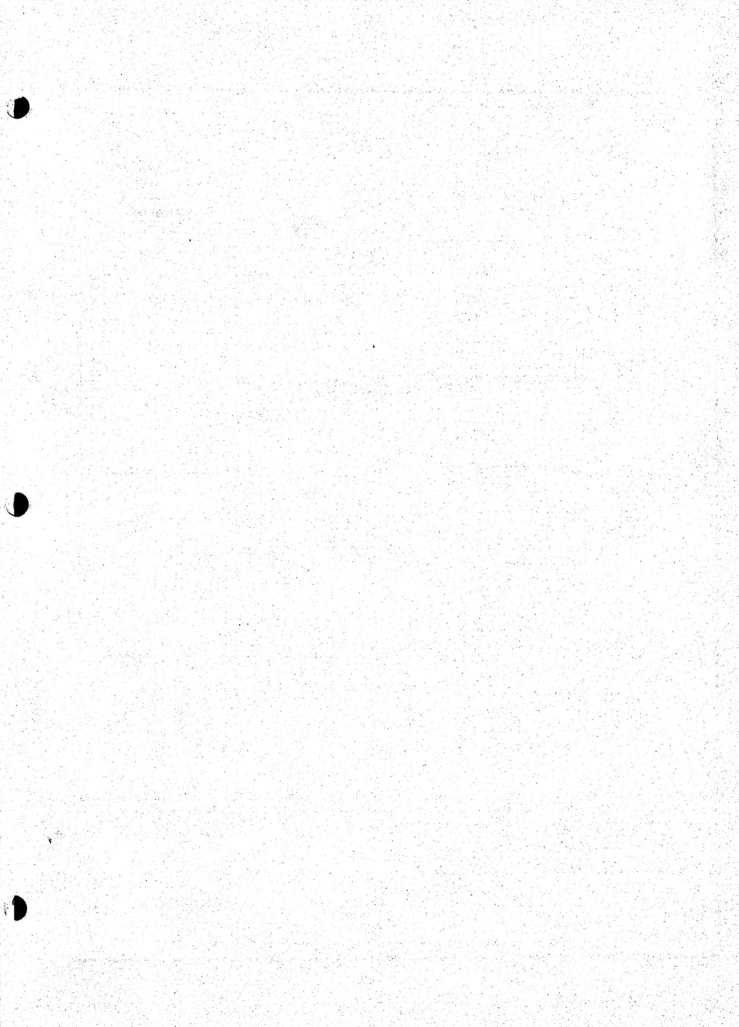

4

3

2

1

REVISIONS				
SYM	DESCRIPTION	INITIALS AND DATE		
		DESIGN	CHECK	ENGR
A	PRODUCTION RELEASE			
B	REV PER ECN 2821.2003			

INTERRUPT
EVENT DATA

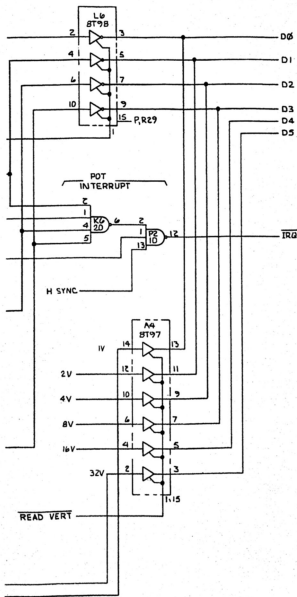

INTERRUPT EVENT
TIME DATA

NOTES: UNLESS OTHERWISE SPECIFIED:
1. RESISTANCE VALUES ARE IN OHMS.
2. CAPACITANCE VALUES ARE IN MICROFARADS.

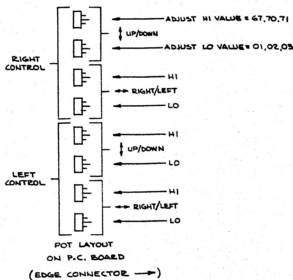

EXTERNAL INPUTS

NOTICE TO ALL PERSONS RECEIVING THIS DRAWING
CONSEQUENTIAL. Reproduction is prohibited without the express
written permission of Atari, Inc. Atari, California, is the
owner of the copyright in this drawing and all rights in it.
This drawing is the property of Atari, Inc. and is to be used
only for the purpose for which it was prepared. It is not to be
reproduced, stored in a retrieval system, or transmitted in any
form or by any means, electronic, mechanical, photocopying,
recording, or by any information storage and retrieval system,
without the express written permission from Atari, Inc.

DATE	3/9/76
DESIGNER	...
CHECKED	...
PROJECT ENGINEER	...
DOCUMENT CONTROL	...
APPROVED	...
DATE	...
BY	...
NO.	...

DIVISION THE DRAWING PER USE THIS UNLESS OTHERWISE SPECIFIED DIMENSIONS ARE IN INCHES TOLERANCES ON FRACTIONS ±.015 0.005 DECIMALS ±.005 HOLE DIA ±.005 HOLE DIA ±.005	DRAWN BY DATE CHECKED DESIGN ENGINEER PROJECT ENGINEER DOCUMENT CONTROL APPROVED	ATARI INCORPORATED 1400 Woodhurst Boulevard Los Gatos, California 95030 TITLE SCHEMATIC, FLYBALL SHEET NO. D DRAWING NO. 005629-01 REV. BY B SHEET 1 OF 9
--	--	---

4

3

2

1

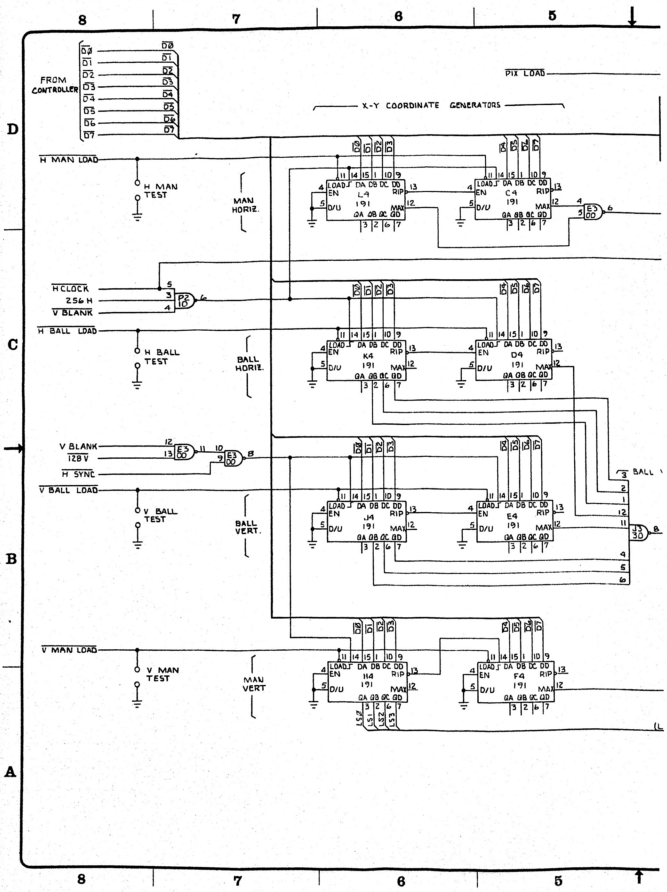

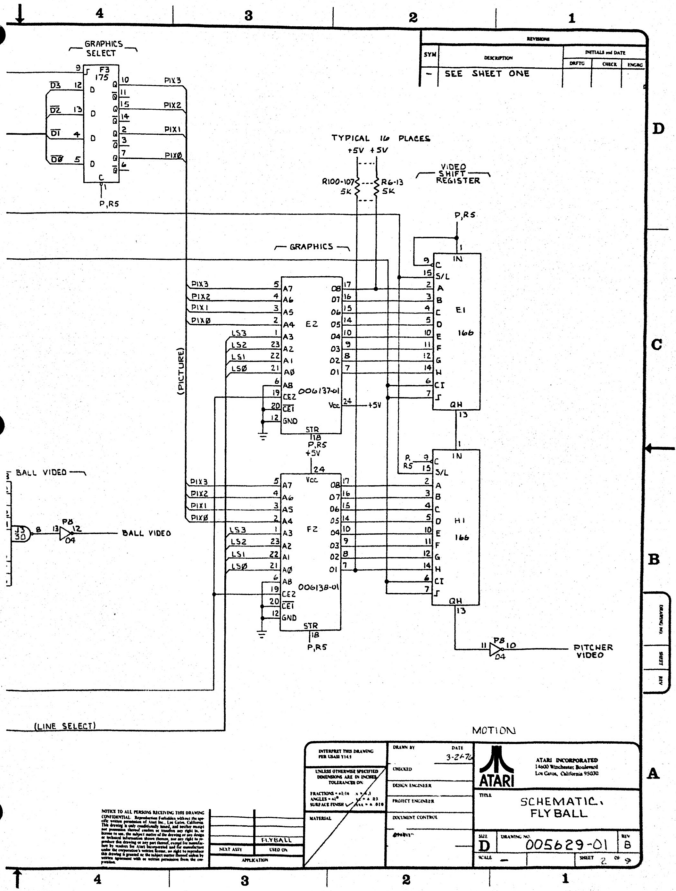

REVISION		
SYM	DESCRIPTION	DETAILS and DATE
		DRF:JC CMC:K ENG:AG
-	SEE SHEET ONE	

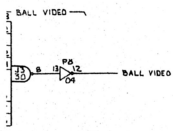
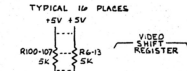

(LINE SELECT)

MOTION

<p>INTERPRET THIS DRAWING FOR READ TITLE</p> <p>UNLESS OTHERWISE SPECIFIED DIMENSIONS ARE IN INCHES TOLERANCES ON:</p> <p>FRACTIONS - ±0.10</p> <p>ANGLES - ±0°</p> <p>SURFACE FINISH - AS MANUFACTURED</p>	<p>DRAWN BY</p> <p>CHECKED</p> <p>SEEN ENGINEER</p> <p>PROJECT ENGINEER</p> <p>INVENTOR/CONTR.</p>	<p>DATE</p> <p>3-2-78</p>	<p>ATARI INCORPORATED</p> <p>1400 Winchester Boulevard</p> <p>Los Gatos, California 95030</p>
	<p>TITLE</p> <p>SCHEMATIC, FLYBALL</p>		
	<p>MATERIAL</p> <p>FLYBALL</p> <p>WASH ASSY</p> <p>USED ON</p> <p>APPLICATION</p>	<p>REV</p> <p>D</p> <p>DRAWING NO.</p> <p>005629-01</p> <p>REV B</p>	
	<p>SHEET 2 OF 2</p>		

NOTE TO ALL PERSONS RECEIVING THIS DRAWING

UNLESS OTHERWISE SPECIFIED DIMENSIONS ARE IN INCHES TOLERANCES ON:

FRACTIONS - ±0.10

ANGLES - ±0°

SURFACE FINISH - AS MANUFACTURED

IF THIS DRAWING IS TO BE USED FOR ANY OTHER PURPOSE THAN THAT FOR WHICH IT WAS DESIGNED, THE USER ASSUMES ALL LIABILITY FOR ANY DAMAGE OR INJURY THAT MAY BE CAUSED BY SUCH USE.

D

C

B

A

NO DIMENSIONS
LEADER
DATE

4

3

2

1

4

3

2

1

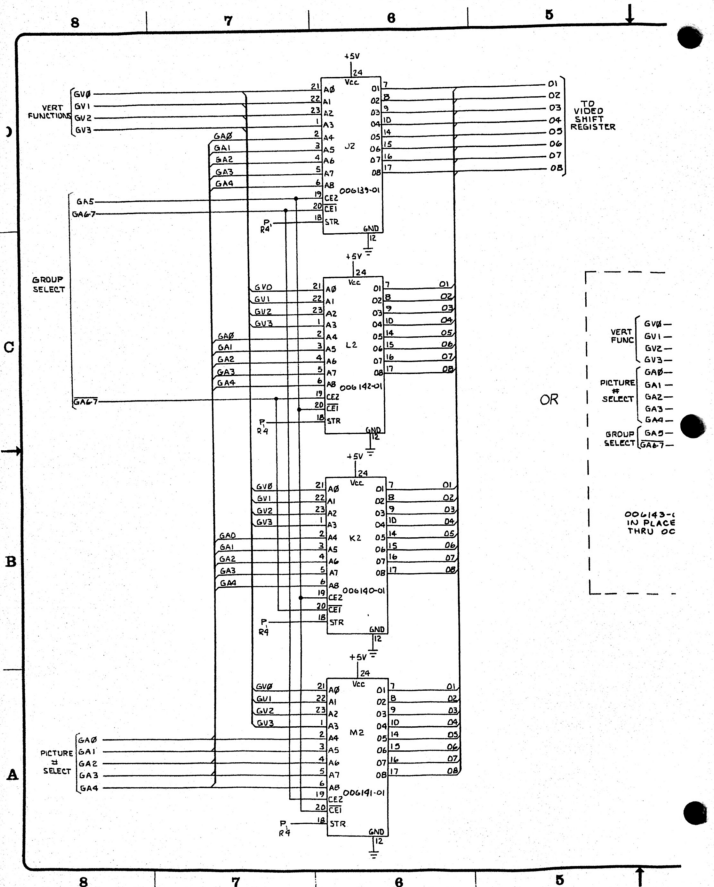

D

C

B

A

8

7

6

5

8

7

6

5

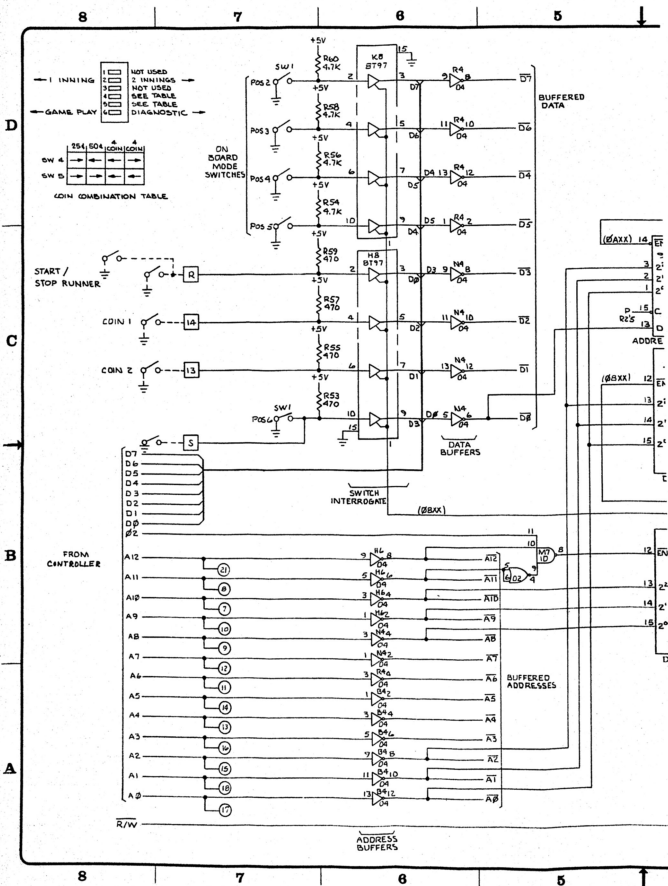

1 INNING
 2 INNINGS
 3 NOT USED
 4 NOT USED
 5 SEE TABLE
 6 SEE TABLE
 7 DIAGNOSTIC

COIN COMBINATION TABLE

SW 4	554	504	4	COM1	COM2
SW 5					

ON BOARD MODE SWITCHES

START / STOP RUNNER

COIN 1

COIN 2

BUFFERED DATA

DATA BUFFERS

SWITCH INTERROGATE

BUFFERED ADDRESSES

ADDRESS BUFFERS

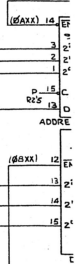

D

C

B

A

8

7

6

5

8

7

6

5

REVISION				
BY	DESCRIPTION	INITIALS	DATE	
-	SEE SHEET ONE			

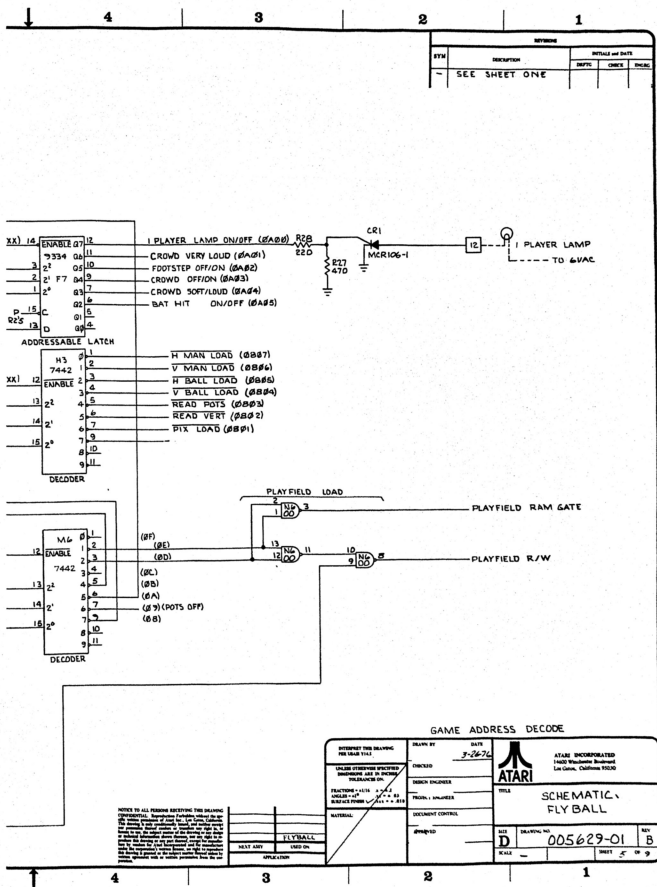

GAME ADDRESS DECODE

INTERPRET THE DRAWING THE HARD WAY. UNLESS OTHERWISE SPECIFIED DIMENSIONS ARE IN INCHES. FINISHES - ALL S. & B. UNLESS NOTED OTHERWISE. MATERIAL NEXT AND USED ON APPLICATION	DRAWN BY DATE 3-26-76	ATARI INCORPORATED 1400 Woodside Boulevard Los Gatos, California 95030		
	CHECKED DESIGN ENGINEER PROJECT MANAGER DOCUMENT CONTROL		TITLE SCHEMATIC FLY BALL	
	PART NO. REV D		DRAWING NO. 005629-01	REV B
	SCALE		SHEET 2 OF 9	

NOTE TO ALL PERSONS RECEIVING THIS DRAWING
 CONFIDENTIAL. Reproduction Forbidden without the
 express approval of Atari Inc. For Atari California
 and Atari International, contact Atari Inc., 1400
 Woodside Boulevard, Los Gatos, California 95030.
 For Atari Japan, contact Atari Inc., 1400 Woodside
 Boulevard, Los Gatos, California 95030.
 For Atari Europe, contact Atari Inc., 1400 Woodside
 Boulevard, Los Gatos, California 95030.
 For Atari Australia, contact Atari Inc., 1400 Woodside
 Boulevard, Los Gatos, California 95030.

REVISIONS		
SYM	DESCRIPTION	INITIALS AND DATE
-	SEE SHEET ONE	ENFC

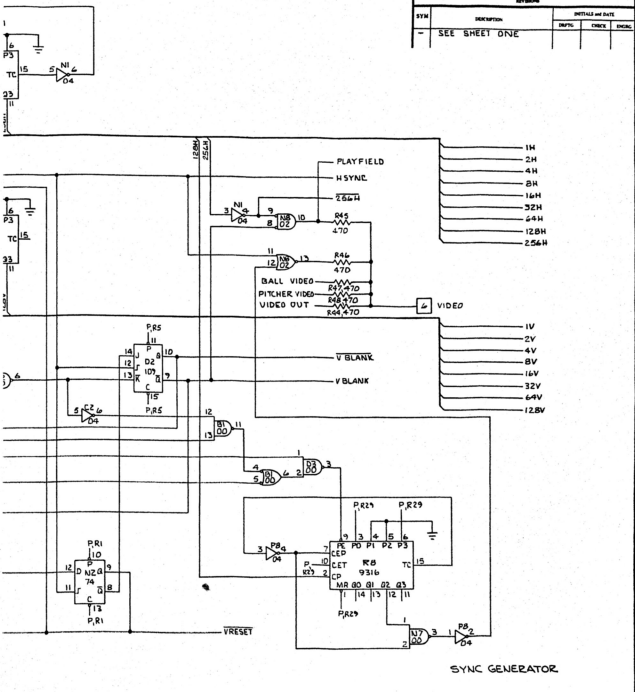

SYNC GENERATOR

NOTES TO ALL PERSONS RECEIVING THIS DRAWING:
 CONFIDENTIAL: Reproduction prohibited without the
 written consent of Atari, Inc. For License Call
 The drawing is not to be used for any other purpose
 without the written consent of Atari, Inc. It is
 to be used only for the purpose intended and is not
 to be reproduced or transmitted in any form or
 by any means electronic, mechanical, photocopying,
 recording, or by any information storage and retrieval
 system, or in any manner now known or hereafter
 invented, or by any means that may be developed
 in the future. Atari, Inc. is not responsible for any
 errors or omissions in this drawing.

INTERPRET THE DRAWING FOR YOUR FILE	DRAWN BY	DATE
UNLESS OTHERWISE SPECIFIED DIMENSIONS ARE IN INCHES TOLERANCES ON:	CHECKED	4/2/74
FRACTIONS - 1/16" = .0625"	DESIGN ENGINEER	
DECIMALS - 1/10" = .010"	PROJECT ENGINEER	
NEAREST FITTING SIZE = .005"	DOCUMENT CONTROL	
NATURAL	APP'D BY	
FLY BALL	DATE	
LOAD ON	SCALE	
APPLICATION		

<p>ATARI INCORPORATED 1400 Webster Boulevard Los Gatos, California 95030</p>		TITLE SCHEMATIC, FLYBALL
DRAWING NO. 005629-01		
SHEET 1 OF 3	DATE	REV B

8

7

6

5

TO ALL PERSONS RECEIVING THIS DRAWING
OF THE INFORMATION CONTAINED HEREIN, THE
DRAWING IS THE PROPERTY OF THE U.S. GOVERNMENT
AND IS NOT TO BE REPRODUCED, COPIED, OR
TRANSMITTED IN ANY MANNER WITHOUT THE
WRITTEN PERMISSION OF THE U.S. GOVERNMENT
OFFICE OF NAVAL ARCHITECTURE, WASHINGTON, D.C.

NOTES: UNLESS OTHERWISE SPECIFIED

8

7

6

5

4

3

2

1

REVISION				
ZONE	SYM	DESCRIPTION	DATE	APPROVED
-	-	SEE SHEET ONE		

D

ON ORDER

LIST

USE

C

NOTE:

THE INFORMATION ON THIS SHEET WAS NOT REPRODUCED
BECAUSE IT COVERS CIRCUITRY THAT IS NOT OPERATOR-
REPAIRABLE.

B

OUTSTANDING ECNs	

A

UNLESS OTHERWISE SPECIFIED DIMENSIONS ARE IN INCHES TOLERANCES ON		DO NOT SCALE DRAWING		 ATARI INCORPORATED 1400 Winchester Boulevard Los Gatos, California 95020
ANGLES - 16° SURFACE FINISH ✓ 125 - 25 ✓ 125 - 25		DRAWN BY DATE 9-5-76		
MATERIAL		CHECKED		TITLE SCHEMATIC, FLYBALL
FINISH		ENGINEER		SIZE DRAWING NO D 005629
PROJECT ENGINEER		PROJECT ENGINEER		REV B
NEXT ASSY USED ON		MFG ENGINEER		SCALE SHEET # OF 9
APPLICATION				

4

3

2

1

8

7

6

5

CONCEPT

D

C

B

A

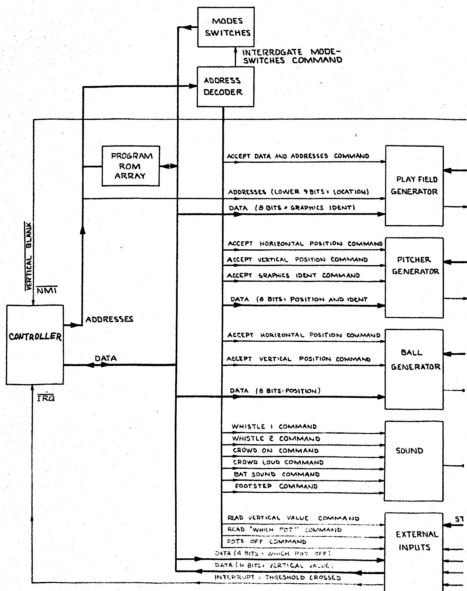

8

7

6

5

TUAL BLOCK DIAGRAM

REVISION				
SYM	DESCRIPTION	INITIALS and DATE		
		DESIGN	CHECK	DRAWN
-	SEE SHEET ONE			

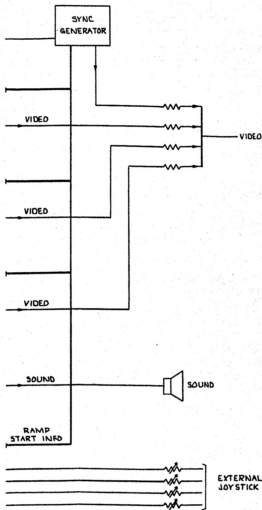

BLOCK DIAGRAM

NOTES FOR ALL PERSONS RECEIVING THIS DRAWING:
 OPERATIONAL: Reproduction prohibited without the
 written consent of Atari, Inc., 101 Canyon Blvd.,
 Redwood City, California 94061. This drawing is
 the property of Atari, Inc. and is to be used only for
 the specific purpose for which it was prepared. It
 is not to be used for any other purpose without the
 written consent of Atari, Inc. This drawing is to be
 used only for the specific purpose for which it was
 prepared and is not to be used for any other
 purpose without the written consent of Atari, Inc.

DATE	
BY	FLYBALL
CHECKED	
DESIGN ENGINEER	
PROJECT ENGINEER	
DOCUMENT CONTROL	
APPROVED	
SCALE	
SHEET	9 OF 9

INTERPRET THIS DRAWING FOR USER ONLY UNDER OTHERWISE SPECIFIED DIMENSIONS ARE IN INCHES UNLESS NOTED OTHERWISE FRACTIONS = 1/16" X 1/8" X 3/16" DECIMALS = 0.015" X 0.030" X 0.045" DIMENSIONS FROM SURFACE UNLESS NOTED OTHERWISE	DRAWN BY DATE 4/5/76	ATARI INCORPORATED 10101 Washington Boulevard Los Gatos, California 95030
MATERIAL: FLYBALL	TITLE SCHEMATIC FLYBALL	DRAWING NO. 005629-01
NEXT ASST USED ON APPLICATION	SCALE SHEET 9 OF 9	REV B



ASSEMBLY TITLE / FLYBALL P.C. ASSY.

P/L A005629-01

PARTS LIST SPECIFICATION

Page 1 of 5

Drawn	N/A A005292-01		
Checked	Mech. Eng.		
Proj. Eng.	Elec. Eng.		REV. B

Rev.	Description	Date	Apprv.	Rev.	Description	Date	Apprv.
A	PROD. REL.	6/24/76					
B	REV PER ECN 2821, 2883	2-2-77					

Item	Part Number	Qty.	DESCRIPTION				
1	005630-01	1	Printed Circuit BD.				
2	10-5102	11	RES., CARBON, 5%, 1/4w, 1K			R1,4,5,23,25,29, 30,73,74,87,79	
3	10-5103	13	" " " " 10K			R31-34,37-40, 89-91,97,98	
4	10-5104	2	" " " " 100K			R78,76	
5	10-5106	4	" " " " 10M			R49-52	
6	10-5221	1	" " " " 220			R28	
7	10-5223	2	" " " " 22K			R24,61	
8	10-5272	8	" " " " 2.7K			R14-21	
9	10-52P7	1	" " " " 2.7			R93	
10	10-5330	1	" " " " 33			R94	
11	10-5331	2	" " " " 330			R2,3	
12	10-5471	10	" " " " 470			R27,44-48,53, 55,57,59	
13	10-5472	4	" " " " 4.7K			R56,58,60,54	
14	10-5562	16	" " " " 5.6K			R6-13,R100-107	
15	10-5821	1	" " " " 820			R77	
16	10-5124	1	" " " " 120K			R35	
17	10-5154	1	" " " " 150K			R36	
18	10-5683	1	" " " " 68K			R43	
19	19-315252	8	TRIMPOT, 2K			R63-70	
20	19-315103	1	" 10K			R95	
21	19-315503	2	" 50K			R26,75	
22	19-8D9W2P0	1	RES., WIREWOUND 10%, 20W, 2 OHM			R62,	

PARTS LIST SPECIFICATION

REV. B

Page 2 of 5

Item	Part Number	Qty.	DESCRIPTION
23	10-5332	1	RES., CARBON, 5%, $\frac{1}{4}$ W, 3.3K R88
24	10-5333	1	" " " " 33K R99
25	10-5473	2	" " " " 47K R96,92
26	21-101104	1	CAP., MYLAR, .1uf C26
27			
28	21-101472	2	" " .0047uf C34,44
29	10-5334	1	RES, CARBON 5%, $\frac{1}{4}$ W, 330K R80
30			
31	24-250507	1	CAP., ELECTROLYTIC, 500uf, 25V C15
32	24-250105	4	" " 1uf, 25V C27,28,30,31
33	24-250107	1	" " 100uf,25V C49
34	24-250108	1	" " 1000uf,25V C43
35	24-250478	1	" " 4700uf,25V C42
36	24-160808	2	" " 8000uf,16V C41,82
37	24-250106	1	" " 10uf, 25V C48
38			
39	27-250202	1	CAP., CERAMIC DISC., .002uf,25V C54
40	21-101153	2	" MYLAR .015uf,100V C46,47
41			
42	27-250104	34	" CERAMIC DISC, .1uf,25V C1-3,5-14,17-23,25, 29,36,40,45,50-53, 55,57,79-81
43	28-101050	1	CAP., DIPPED MICA, 5pf,100V C24
44	28-101221	1	" " " 220pf,100V C56
45			
46			
47	31-MCR106-1	1	SCR, MCR106 CR1
48	31-A14F	2	DIODE, A14F CR6,7
49			
50			
51	31-MR501	2	DIODE, MR501 CR4,5
52			

Item	Part Number	Qty.	DESCRIPTION	
53				
54				
55	34-2N3643	1	TRANSISTOR, 2N3643	Q1
56				
57				
58				
59	37-7400	7	I.C., 7400	B1, D3, E3, N6, L7, N7, J7
60	37-7402	2	" 7402	R2, N8
61	37-7403	2	" 7403	P4, M4
62	37-7404	7	" 7404	N1, C2, B4, N4, R4, H6, P8
63	37-7408	1	" 7408	C3
64	37-7410	2	" 7410	P2, M7
65	37-7420	4	" 7420	C1, B2, K6, P6
66	37-7430	1	" 7430	J3
67	37-7442	3	" 7442	H3, J6, M6
68	37-7474	5	" 7474	N2, D7, P7, L1, R7
69				
70	37-7486	2	" 7486	A2, E7
71	37-74109	1	" 74109	D2
72	37-9322	2	" 9322	K3, R3
73	37-74166	2	" 74166	E1, H1
74	37-74175	2	" 74175	F3, K7
75	37-74164	2	" 74164	B7, C7
76	37-74191	8	" 74191	C4, D4, E4, F4, H4, J4, K4, L4
77	37-74194	2	" 74194	J1, K1
78	37-9316	6	" 9316	P1, R1, A3, B3, R6, R8
79	90-7015	6	" 2111A	L3, M3, N3, P3, E6, F6
80	37-8T98	1	" 8T98	L6
81	37-9334	1	" 9334	F7
82	37-556	1	" 556	E8
83	37-8T97	3	" 8T97	A4, H8, K8
84	37-LM339	1	" LM339	L8
85	37-741	1	" 741	D8

ASSEMBLY TITLE		FLYBALL P.C. ASSY.		P/L A005629-01	
PARTS LIST SPECIFICATION		REV. B		Page 4 of 5	
Item	Part Number	QTY.	DESCRIPTION	REV. B	
86	37-TDA1004	1	I.C. TDA1004	B9	
87	37-MFC6040	2	" MFC6040	A8,C8	
88	37-MFC3340	2	" MFC3340	A8,C8	
89	37-LA323	(REF)	REGULATOR LA323		
90	006143-01	1	GRAPHICS	HZ	
91	006144-01	(REF)	PROGRAM HL	A5	
92	006145-01	(REF)	PROGRAM LO	C5	
93	006149-01	(REF)	PROGRAM ROM 1000	D5	
94	006130-01	1	" " 1200	F5	
95	006131-01	1	" " 1400	H5	
96	006132-01	1	" " 1600	J5	
97	006133-01	1	" " 1800	K5	
98	006134-01	1	" " 1A00	M5	
99	006135-01	1	" " 1C00	H5	
100	006136-01	1	" " 1E00	H5	
101	006137-01	1	GRAPHICS ROM PITCHER LEFT	E2	
102	006138-01	1	" " PITCHER RIGHT	F2	
103	006139-01	1	" " RUNNER	J2	
104	006140-01	1	" " NUMBERS	K2	
105	006141-01	1	" " CHARACTER SET	H2	
106	006142-01	1	" " DIAMOND PARTS	L2	
107					
108	78-06009	1	HEATSINK, TDA 1004	B9	
109	78-13016	A/R	ADHESIVE, THERMAL CONDUCTIVE	B9	
110	66-116P1T	1	SWITCH, 6 POS., DIP	SW1	
111	90-6009	1	I.C.	C6	
112	72-1608C	2	SCREW, PAN HD., PHIL., 6-32x1LG	CN5	
113	75-0165	2	WASHER, FLAT, REC PATTERN, #6, STEEL		

ASSEMBLY TITLE		FLYBALL P.C. ASSY.		P/L A005629-01	
PARTS LIST SPECIFICATION		REV. B		Page 5 of 5	
Item	Part Number	QTY.	DESCRIPTION	REV. B	
115	75-316C	2	NUT, HEX, #6-32, CNES		
116	78-06001	1	HEATSINK		
117	78-16005	1	SILPAD		
118	79-42524	8	24 PIN SOCKET	05,F5,H5,J5,K5,M5,N5,R5	
119	79-42540	1	40 PIN SOCKET	C6	
120	90-102	1	CRYSTAL, 12.098 MHZ	Y1	
121	75-056	2	WASHER, INTERNAL STAR #6		
			* MFC3340 is to replace MFC6040 when stock of MFC6040 is depleted.		
			**006143-01 can be installed in position H2 in place of 006139-01 thru 006142-01 in position J2 thru L2; and 006144-01 position A5 and 006145-01 position C5 can be installed in place of 006129-01 thru 006136-01 in position D5 thru P5.		

8

7

6

5

NOTES TO ALL PERSONS RECEIVING THIS DELIVERY
 CONFIDENTIAL: Reproduction prohibited without the
 prior written permission of the FBI. This document
 contains information that is exempt from public release
 under the Freedom of Information Act, 5 U.S.C. 552.
 This document contains information that is exempt from
 public release under the Privacy Act, 5 U.S.C. 552a.
 This document contains information that is exempt from
 public release under the Espionage Laws, 18 U.S.C.
 793 and 794. This document contains information that
 is exempt from public release under the Atomic Energy
 Laws, 42 U.S.C. 2141 and 2142. This document
 contains information that is exempt from public release
 under the National Security Laws, 50 U.S.C. 1702
 and 1705. This document contains information that
 is exempt from public release under the
 Executive Order 12958, 3 CFR 101.1. This document
 contains information that is exempt from public release
 under the Executive Order 12958, 3 CFR 101.1.

D

C

B

A

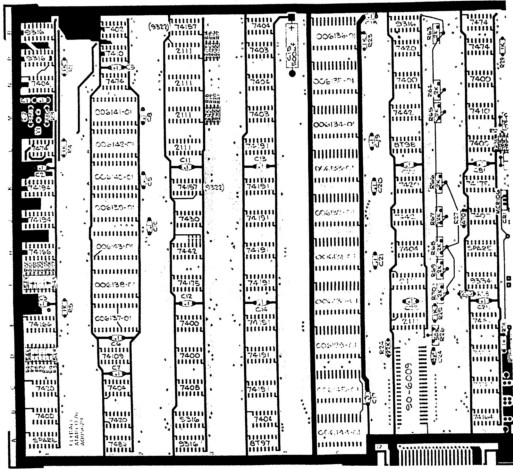

NOTES - UNLESS OTHERWISE SPECIFIED

8

7

6

5



11
94





ATARI INC.
14600 WINCHESTER BLVD
LOS GATOS, CA 95030
408/374-2440 • TELEX 357-488