



GREAT GUNS

INSTALLATION & OPERATION



Stern Electronics, Inc./700 Chase
Elk Grove Village, Illinois 60007
(312) 981-9600 Telex: 254657



TOLL-FREE
Service No.
(800) 621-6424

12G-10-221
REVISION B

SECTION I: GAME DESCRIPTION - GREAT GUNS

The object of the game is to hit as many of the higher scoring targets as possible. All targets are indicated by a white cross.

The targets score from 500 to 9,500 points depending on the difficulty of the target. Each time a shot is fired, a bullet is deducted from the total number of bullets.

The starting number of bullets is adjustable for 60, 70, 80 or 90 bullets. An additional 20 bullets is given to each player when a two player game is played.

Each time either 1,000, 2,000, 3,000, 4,000, 5,000, 6,000, 7,000 or 8,000 points are earned, an additional bullet is added to the total number of bullets.

For every 5 seconds that pass without a shot being fired, 5 bullets will be deducted from the total number of bullets. 5 second time interval decreases in later racks.

The racks are a predetermined time and as long as there are still bullets left when a rack ends, you will enter the next rack.

DESCRIPTION OF THE RACKS (in order of appearance):

Carnival	-	An animated carnival with many targets.
Clown	-	Targets appear from the most unlikely places.
Castle	-	Soldiers, Vikings, The King & Queen, and much, much more.
Catapult	-	Shoot the catapulted rocks, the hot air balloon or the sea monster.
Prehistoric	-	We went way, way back for this one.
Saber Tooth Tiger	-	They are running in every direction & they get faster.
Carnival	-	Same as above.
Balloon	-	Shoot the balloons before they burst.
Castle	-	Same as above.
Sorcerer	-	Puffs of smoke emanate from his finger tips.
Prehistoric	-	Same as above.
Cave Man	-	Little cave men running from cave to cave, reverse direction when hit.

SECTION II: GAME ADJUSTMENTS

All dip switches used for game adjustments are located on the ZPU-2000 board. The ZPU-2000 board is the bottom board in the card cage.

ZPU-2000 DIP SWITCH DESIGNATION

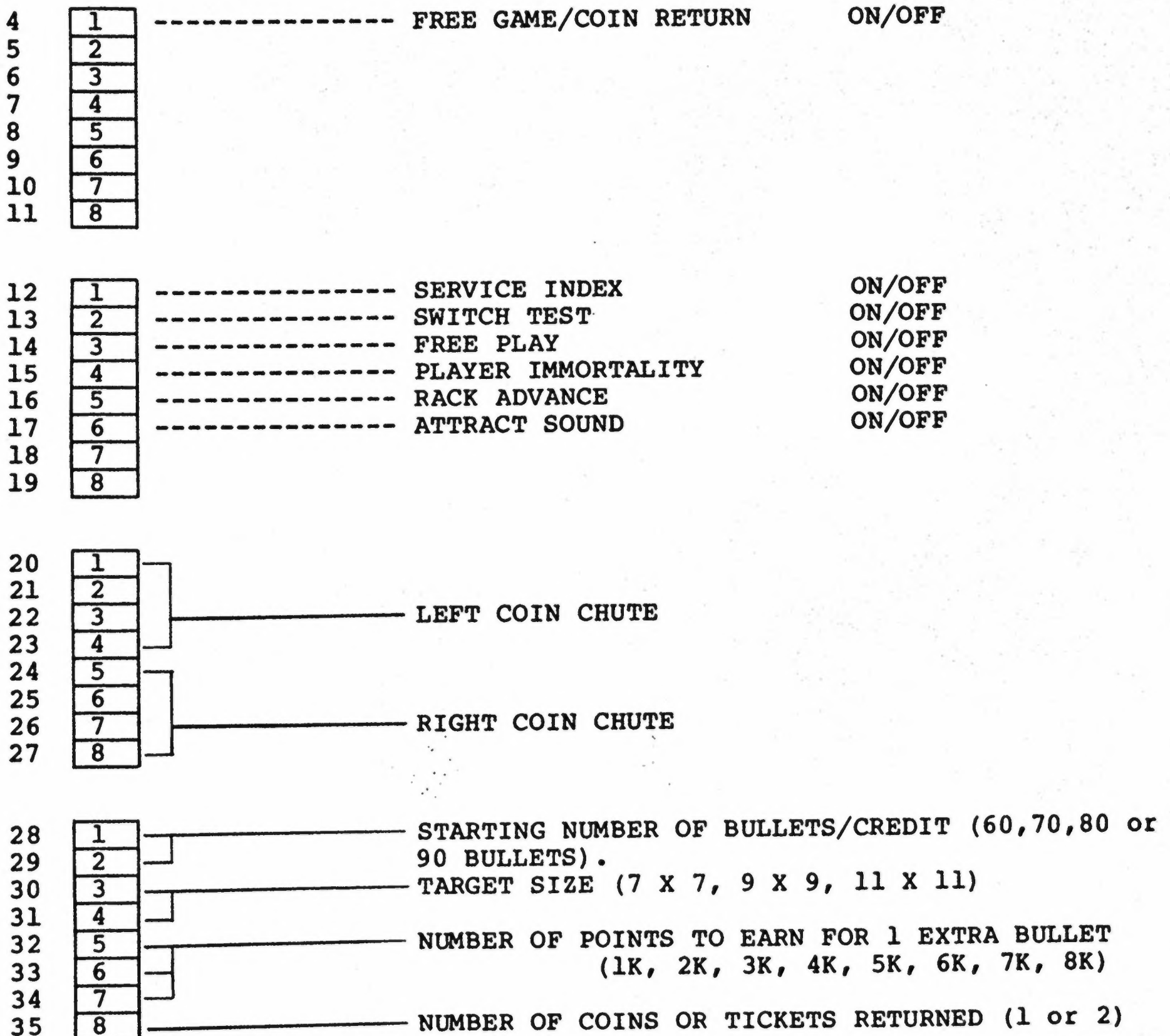

SECTION II:

GAME ADJUSTMENTS (Cont'd)

FREE PLAYYES
NODIP SWITCH 14ON
OFFPLAYER IMMORTALITYYES
NODIP SWITCH 15ON
OFF

Used for Test or demonstration purposes, in this mode your player is never destroyed.

RACK ADVANCEYES
NODIP SWITCH 16ON
OFF

Used for test or demonstration purposes, in this mode pushing the Player One Button displays the next rack on the monitor screen. Pushing the button again, advances to the next rack.

ATTRACT MODE SOUND OFFON
OFFDIP SWITCH 17ON
OFFSTARTING NUMBER
OF BULLETS/CREDIT:BULLETS60
70
80
90SWITCH 28OFF
ON
OFF
ONSWITCH 29OFF
OFF
ON
ON

These numbers are for one player only. If two players play, each player starts with 20 additional bullets - 80, 90, 100, 110

TARGET SIZE:

SIZE7 X 7
9 X 9
11 X 11
7 X 7SWITCH 30OFF
ON
OFF
ONSWITCH 31OFF
OFF
ON
ON

SECTION II:

GAME ADJUSTMENTS (Cont'd)

NUMBER OF POINTS TO EARN FOR EACH EXTRA BULLET:

<u>POINTS</u>	<u>SWITCH 32</u>	<u>SWITCH 33</u>	<u>SWITCH 34</u>
1,000	OFF	OFF	OFF
2,000	ON	OFF	OFF
3,000	OFF	ON	OFF
4,000	ON	ON	OFF
5,000	OFF	OFF	ON
6,000	ON	OFF	ON
7,000	OFF	ON	ON
8,000	ON	ON	ON

NUMBER OF COINS OR TICKETS RETURNED:

One Coin or Ticket Returned
Two Coins or Tickets Returned

DIP SWITCH 35

OFF
ON

This switch is used when an optional coin return or ticket dispenser is used.

COIN SWITCH SETTINGS:

<u>COIN</u>	<u>SWITCHES</u>					
LEFT CHUTE	23	22	21	20		
RIGHT CHUTE	27	26	25	24		
	OFF	OFF	OFF	OFF	CREDITS	COIN
	OFF	OFF	OFF	OFF1	
	OFF	OFF	OFF	ON2	
	OFF	OFF	ON	OFF3	
	OFF	OFF	ON	ON4	
	OFF	ON	OFF	OFF51
	OFF	ON	OFF	ON6	
	OFF	ON	ON	OFF7	
	OFF	ON	ON	ON10	
	ON	OFF	OFF	OFF14	

SECTION II:

GAME ADJUSTMENTS (Cont'd)

COIN	SWITCHES			
LEFT CHUTE	23	22	21	20
RIGHT CHUTE	27	26	25	24

				SEQUENCE OF CREDITS PER COIN					
				CREDITS	COIN	1	2	3	4
✓ ON	OFF	OFF	ON	.1	.2	.0	.1		
ON	OFF	ON	OFF	.3	.2	.1	.2		
ON	OFF	ON	ON	.5	.2	.0	.5		
ON	ON	OFF	OFF	.7	.2	.0	.7		
ON	ON	OFF	ON	.3	.4	.0	.1	.0	.2
ON	ON	ON	OFF	.5	.4	.1	.1	.1	.2
ON	ON	ON	ON	.7	.4	.1	.2	.1	.3

IF BOTH COIN CHUTES ARE ADJUSTED THE SAME, FOR MULTIPLE COINS, CREDITS WILL INCREASE AS IF DROPPED IN SAME CHUTE.

SECTION III:

SERVICE MODES

Your game is using the new Color Frame Buffer (C.F.B.) Hardware System, one of the more advanced systems in the industry today.

The CFB provides three service modes:

- (1) Power on self test for each board
- (2) Service Index
- (3) Switch Test

I. POWER ON SELF TEST:

There are three boards in the C.F.B. System:

- 1) ZPU-2000
- 2) CFB-1001
- 3) PSB-1000

Each board has its own test L.E.D. and each board goes through its own self test on power-up. Each flash checks a particular section of the board. The L.E.D. flashes upon completion of a test. In all cases, if L.E.D. does not come on at all, then check the Z-80 Processor.

Listed below, by board, are the sequence of LED flashes and what section of the board is being checked. If LED stays lit, the test has failed.

ZPU-2000:

6 Flashes (7 Flashes when Bookkeeping Ram Test is executed):

- 1st = Rom 0 Position H1
- 2nd = Rom 1 Position H2
- 3rd = Rom 2 Position H3
- 4th = Rom 3 Position H4
- 5th = Scratch Ram C6
- 6th = Shared Ram

Chip located at Position F3 on CFB Board. ZPU Board must be able to "talk" to the CFB Board to complete this test.

Optional Bookkeeping Ram Test:

- 7th = Bookkeeping and Gun Zone Adjustments Ram F6
- If problems are encountered with bookkeeping or zone adjustments changing value randomly, this test should be run. To initiate the test, hold switch 1 or 2 on the ZPU 2000 during power-up tests.

PSB-1000:

2 Flashes:

- 1st = Eprom 0 A4
- 2nd = Scratch Ram A5

(B)

SECTION III

SERVICE MODES (Cont'd)

CFB-1000:

26 Flashes:

1st	=	Rom 0	Program Prom	F7		
2nd	=	Rom 1	Program Prom	F8		
3rd	=	Rom 0	Pattern Prom	- ON	PSB-1000	G5
4th	=	Rom 1	Pattern Prom	- ON	PSB-1000	F5
5th	=	Rom 2	Pattern Prom	- ON	PSB-1000	D5
6th	=	Rom 3	Pattern Prom	- ON	PSB-1000	C5
7th	=	Rom 4	Pattern Prom	- ON	PSB-1000	G6
8th	=	Rom 5	Pattern Prom	- ON	PSB-1000	F6
9th	=	Rom 6	Pattern Prom	- ON	PSB-1000	D6
10th	=	Rom 7	Pattern Prom	- ON	PSB-1000	C6
11th	=	Rom 8	Pattern Prom	- ON	PSB-1000	G7
12th	=	Rom 9	Pattern Prom	- ON	PSB-1000	F7
13th	=	Rom 10	Pattern Prom	- ON	PSB-1000	D7
14th	=	Rom 11	Pattern Prom	- ON	PSB-1000	C7
15th	=	Rom 12	Pattern Prom	- ON	PSB-1000	G8
16th	=	Rom 13	Pattern Prom	- ON	PSB-1000	F8
17th	=	Rom 14	Pattern Prom	- ON	PSB-1000	D8
18th	=	Rom 15	Pattern Prom	- ON	PSB-1000	C8
19th	=	Rom 16	Pattern Prom	- ON	PSB-1000	G9
20th	=	Rom 17	Pattern Prom	- ON	PSB-1000	F9
21st	=	Rom 18	Pattern Prom	- ON	PSB-1000	D9
22nd	=	Rom 19	Pattern Prom	- ON	PSB-1000	C9
23rd	=	Rom 20	Pattern Prom	- ON	PSB-1000	G10
24th	=	Parameter Ram	K13			
25th	=	Custom Video Controller				
26th	=	Shared Ram	F3			

CFB Board must be able to "talk" and "listen" to the ZPU Board to complete this test.

II. SERVICE INDEX:

Access into the Service Index can be made by turning Dip Switch No. 12 of the ZPU Board on and off OR by holding the Service Index Interlock Switch in then releasing. (Service Index Interlock Switch is located in upper right hand corner of the drawer by the power transformer). To exit the Service Index, repeat the procedure for entering.

The service index displays seven (7) categories on the screen, that provide access to Bookkeeping Information, Game and Coin Adjustment Settings, and Various Diagnostic Tests.

A. The categories in the service index are listed below:

- 01 Bookkeeping
- 02 Game Adjustment
- 03 Credit/Coin Adjustment
- 04 Monitor Test
- 05 Sound Test
- 06 Gun Adjustment Mode
- 07 Game Play Statistics

B. Selecting a category:

To select a category you:

- (1) push the Player One button to move the Red Bar up the index.
- (2) push the Player Two button to move the Red Bar down the index.
- (3) To select a category pull the Trigger on either gun.
- (4) To exit from a category, pull the Trigger on either gun.

C. Description of Categories:

01 Bookkeeping: The Bookkeeping category contains information on:

- (1) Total plays
- (2) Coins through the left coin chute.
- (3) Coins through the right coin chute.
- (4) Total coins, tickets or games returned.
- (5) Total seconds played
- (6) Longest game in seconds
- (7) Shortest game in seconds
- (8) Highest game score
- (9) Highest rack played

To reset the categories back to zero, push switch number two (2) on the ZPU-2000 Board (See ZPU illustration, Sec. 4). This resets all categories except number 8, highest game score, this is handled separately.

NOTE: Number 7, shortest game in seconds is reset to 99.

SECTION III

SERVICE MODES (Cont'd)

HIGHEST GAME SCORE:

The CFB System displays twenty (20) high scores in two different categories; All Time and Today.

Scores in the Today column are reset every time the machine is turned off.

Scores in the All Time column are retained in memory and are not reset when the machines is turned off.

Scores in the All Time Column, can be cleared One At A Time by pushing Switch Number One on the ZPU-200 Board (See ZPU Illustration Sec. 4). Each push of Switch One clears the highest score of the group and all other scores move up. To clear the entire column push Switch One, ten (10) times.

02 Game Adjustments:

Displays how a particular adjustment has been set, the dip switches controlling that function, and the status of those switches.

03 Credit/Coin Adjustments:

Show what Coin/Credit combination has been set for both the Left and Right Coin Chutes, and which switches control each chute.

04 Monitor Test:

Displays a Red, Blue, Green or Crosshatch pattern on the screen for monitor adjustments.
To change screens, push the Player One button.

05 Sound Test:

Allows you to test each sound of the game individually. To do this use either the Player One or Player Two buttons to call up the number of the sound (See Chart) you want to test. Pulling the Trigger on either gun starts the sound.

To exit the Sound Test, call up position number 12 (Exit Sound Test) and pull the Trigger on either gun.

LIST OF GAME SOUNDS:

01	Credit
02	Gun Shot
03	Gun Hit
04	Game Over
05	Title Song
06	Carnival Song (Major)
07	Carnival Song (Minor)
08	Medieval Song (Major)
09	Medieval Song (Minor)
10	Prehistoric Song (Major)
11	Prehistoric Song (Minor)
12	Exit Sound Test

06 Gun Adjustment Mode:

This mode allows you to adjust the position of the shot on the screen. The Left Gun Trigger allows you to adjust left gun and the Right Gun Trigger allows you to adjust right gun.

Select the adjustment mode that you want - The Player 1 Button allows you to adjust the "Limit Adjustment". The Player 2 Button allows you to adjust the "Zone Adjustment".

Limit Adjustment:

CAUTION: Left Gun: Left - Pot R1, Right - Pot R2, Top - Pot R3, Bottom - Pot R4. This is the proper adjustment sequence for the left gun only.

Right Gun: Left - Pot R1, Right - Pot R2, Bottom - Pot R3, Top - Pot R4. This is the proper adjustment sequence for the right gun only.

This sequence must be followed for proper adjustment.

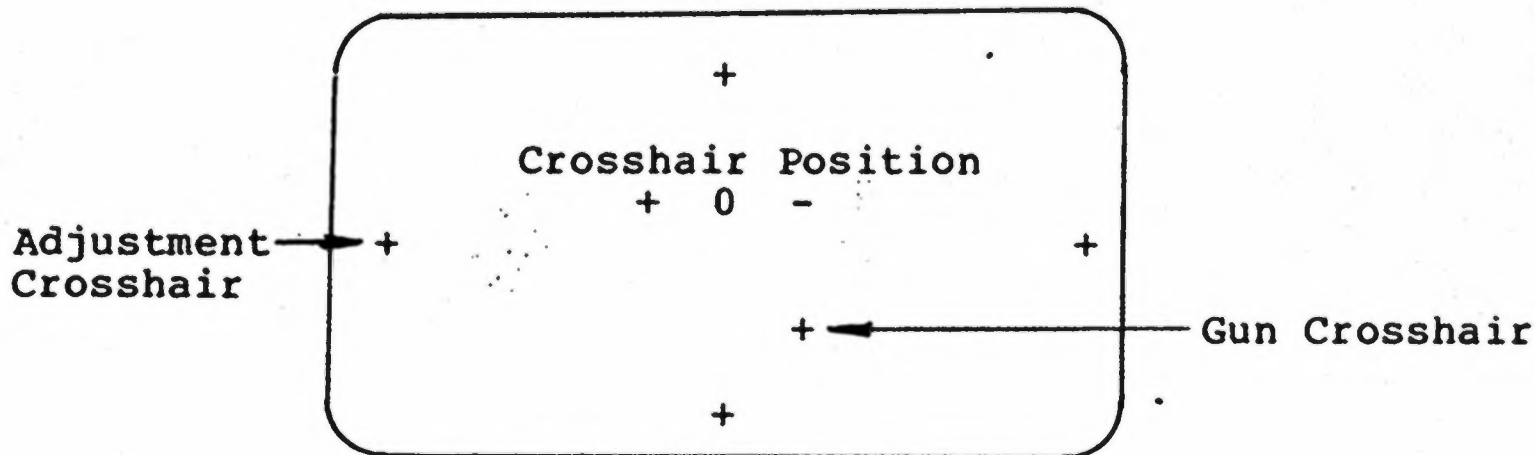

To adjust the "Limit Adjustment", move the gun crosshair to the left adjustment crosshair first, while aiming at it.

NOTE: Only one of the adjustment crosshairs is on the screen at a time. To move the crosshair to the next position pull the trigger on the gun that you are adjusting.

With Pot's on UIB's closest to you, the left board is for the left gun and the right board is for the right gun. Using the adjustment tool, included in the service envelope, adjust all pots on each UIB Board (located behind the coin door. The UIB Mtg. Board unlatches and can be removed for easy service, See UIB Illustration on page 21).

Adjust the pot until the 0 of the crosshair position turns from black to red. For proper final adjustment, the 0 of the crosshair position should be red, and the + and - should be black.

NOTE: THESE ADJUSTMENTS SHOULD BE COMPLETED TWICE TO ASSURE HIGHEST ACCURACY.

To exit this mode, pull the trigger of the opposite gun that you are working on.

SECTION III

SERVICE MODES (Cont'd)

06 Gun Adjustment Mode: (Cont'd)

ZONE ADJUSTMENT:

WHITE BOX AROUND
INTERSECTION IS
ZONE BEING
ADJUSTED

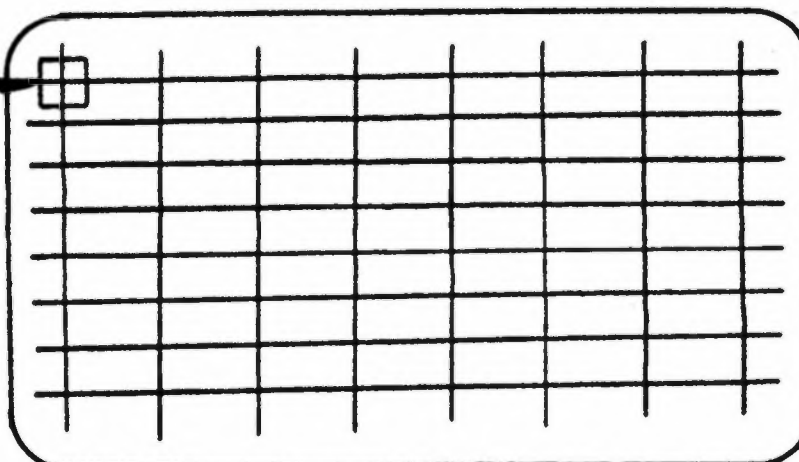

To adjust zones, simply aim at the intersection with the white box around it and pull trigger of gun that you are adjusting. White box will automatically move to the next zone. Repeat this for all zones. CAUTION - you must only pull trigger when aiming at a zone that has the white box around it.

If you wish to move white box back a zone, push Player 1 Button. To move forward, push Player 2 Button.

To exit this mode, pull the trigger of the opposite gun that you are adjusting. The "Limit Adjustment" and the "Zone Adjustment" must be done for each gun.

NOTE: ZONE ADJUSTMENTS ARE STORED IN BOOKKEEPING RAM ON THE ZPU BOARD. IF THE ZPU IS REPLACED, THE ZONE ADJUSTMENTS MUST BE REPEATED.

07 Game Play Statistics:

This category contains information on:

(1) Range of scores:

This page shows the range of scores achieved in 50K points increments. It displays values from 0 to 700K points. It also shows how many times each level was reached.

(2) Range of times:

This page shows the range of time played, in minutes. Times shown are from 0 to 14 minutes and increase at one minute intervals.

(3) Range of racks:

This page shows the number of times the highest rack per game was reached.

Pushing the Player One Button changes the display to the next page.

Pushing the Player Two Button clears the page being displayed back to zero.

SECTION III

SWITCH TEST

The switch test can be turned on two different ways:

- (1) By turning switch number 13 of the ZPU Board on and off.
To exit the Service Index, repeat the procedure for entering.
- (2) Holding the Player One start button closed during power-up.

0 = Switch open

1 = Switch closed

<u>SWITCH</u>	<u>STROBE</u>	<u>BIT</u>
Player One	5	2
Player Two	5	3
Left Gun Trigger	5	4
Right Gun Trigger	5	5
Right Coin Switch	5	0
Left Coin Switch	5	1
ZPU Switch 1	0	6
ZPU Switch 2	0	7
Dip Switch 4	4	0
Dip Switch 5	4	1
Dip Switch 6	4	2
Dip Switch 7	4	3
Dip Switch 8	4	4
Dip Switch 9	4	5
Dip Switch 10	4	6
Dip Switch 11	4	7
Dip Switch 12	3	0
Dip Switch 13	3	1
Dip Switch 14	3	2
Dip Switch 15	3	3
Dip Switch 16	3	4
Dip Switch 17	3	5
Dip Switch 18	3	6
Dip Switch 19	3	7
Dip Switch 20	2	0
Dip Switch 21	2	1
Dip Switch 22	2	2
Dip Switch 23	2	3
Dip Switch 24	2	4
Dip Switch 25	2	5
Dip Switch 26	2	6
Dip Switch 27	2	7
Dip Switch 28	1	0
Dip Switch 29	1	1
Dip Switch 30	1	2
Dip Switch 31	1	3
Dip Switch 32	1	4
Dip Switch 33	1	5
Dip Switch 34	1	6
Dip Switch 35	1	7

SECTION III

SWITCH TEST (Cont'd)

LEFT GUN OR PLAYER 1:

Horizontal movement of gun is Strobe 6, Bits 0 - 7.
Movement is from 0000 0000 to 1111 1111

Vertical movement of gun is Strobe 7, Bits 0 - 7
Movement is from 0000 0000 to 1111 1111.

RIGHT GUN OR PLAYER 2:

Horizontal movement of gun is Strobe 8, Bits 0 - 7.
Movement is from 0000 0000 to 1111 1111

Vertical movement of gun is Strobe 9, Bits 0 - 7
Movement is from 0000 0000 to 1111 1111.

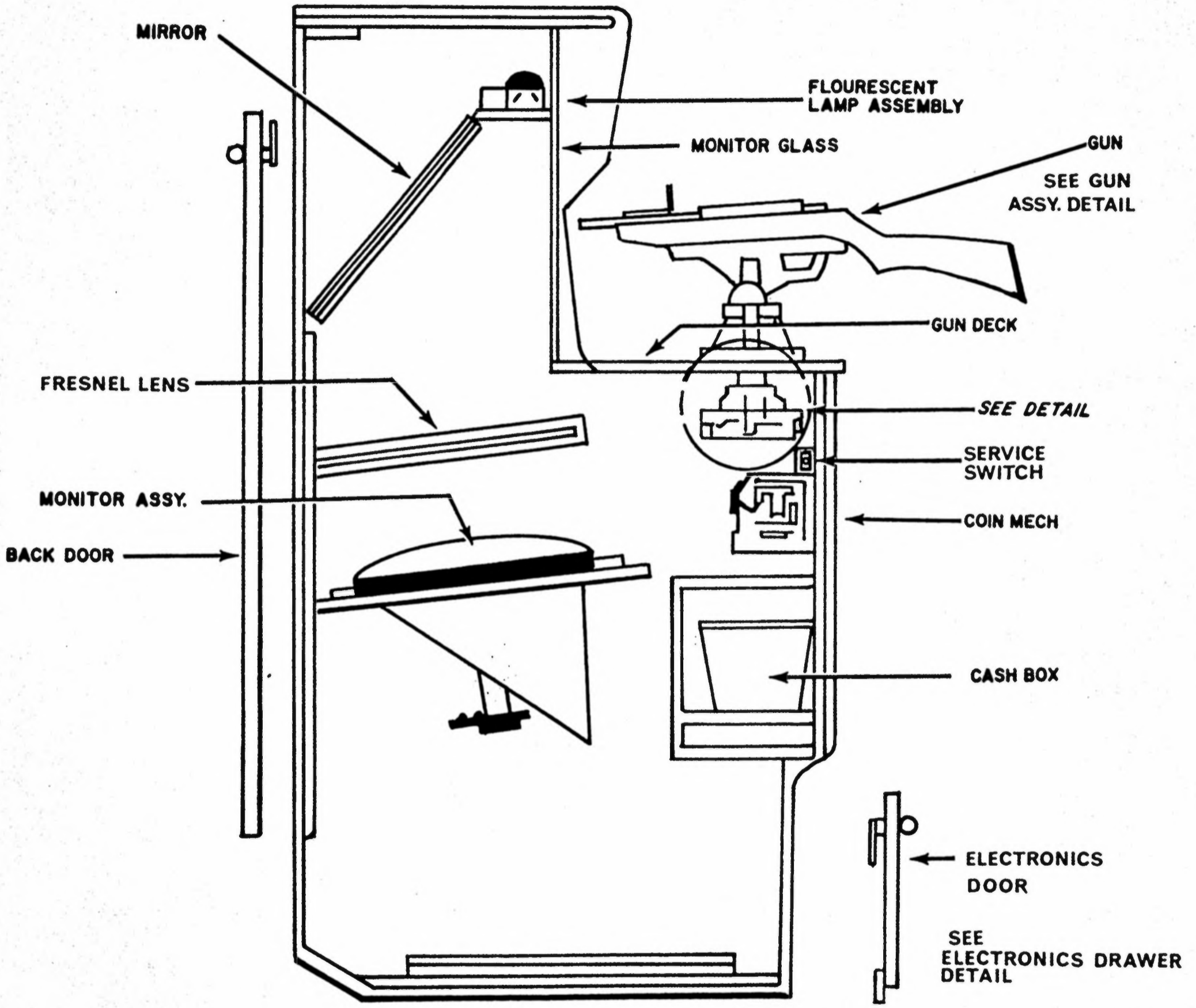

**ELECTRONIC BOARDS
(SEE INDIVIDUAL ILLUSTRATIONS FOR DETAILS)**

5 A. SLOW BLOW FUSE

SERVICE OUTLET

VOLUME CONTROL

LINE FUSE

**POWER
INTERLOCK SWITCH**

**RECOIL
POWER
TRANSFORMER**

LINE FILTER

**POWER
TRANSFORMER**

POWER SUPPLY

15

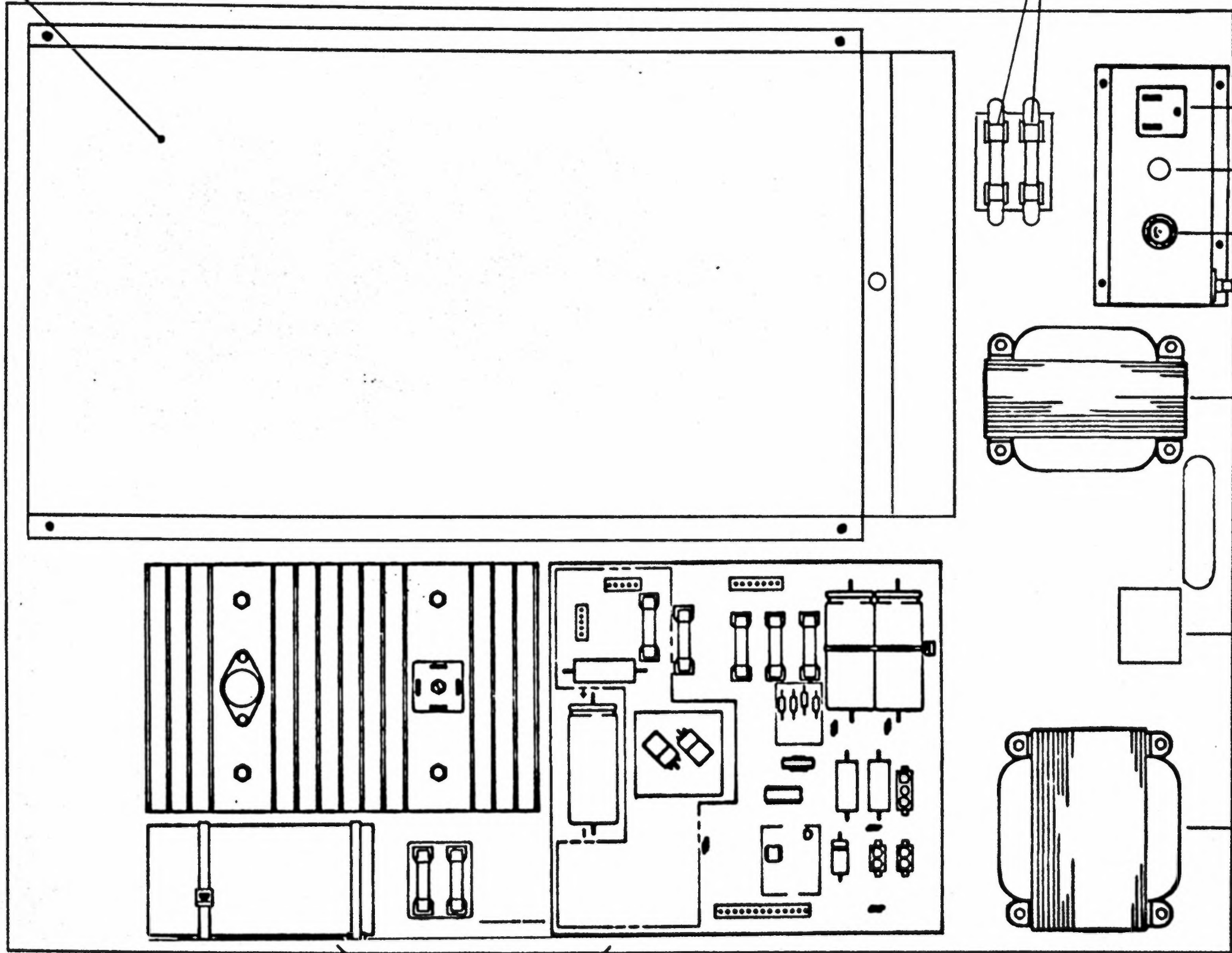

ZPU P.C. BOARD

16

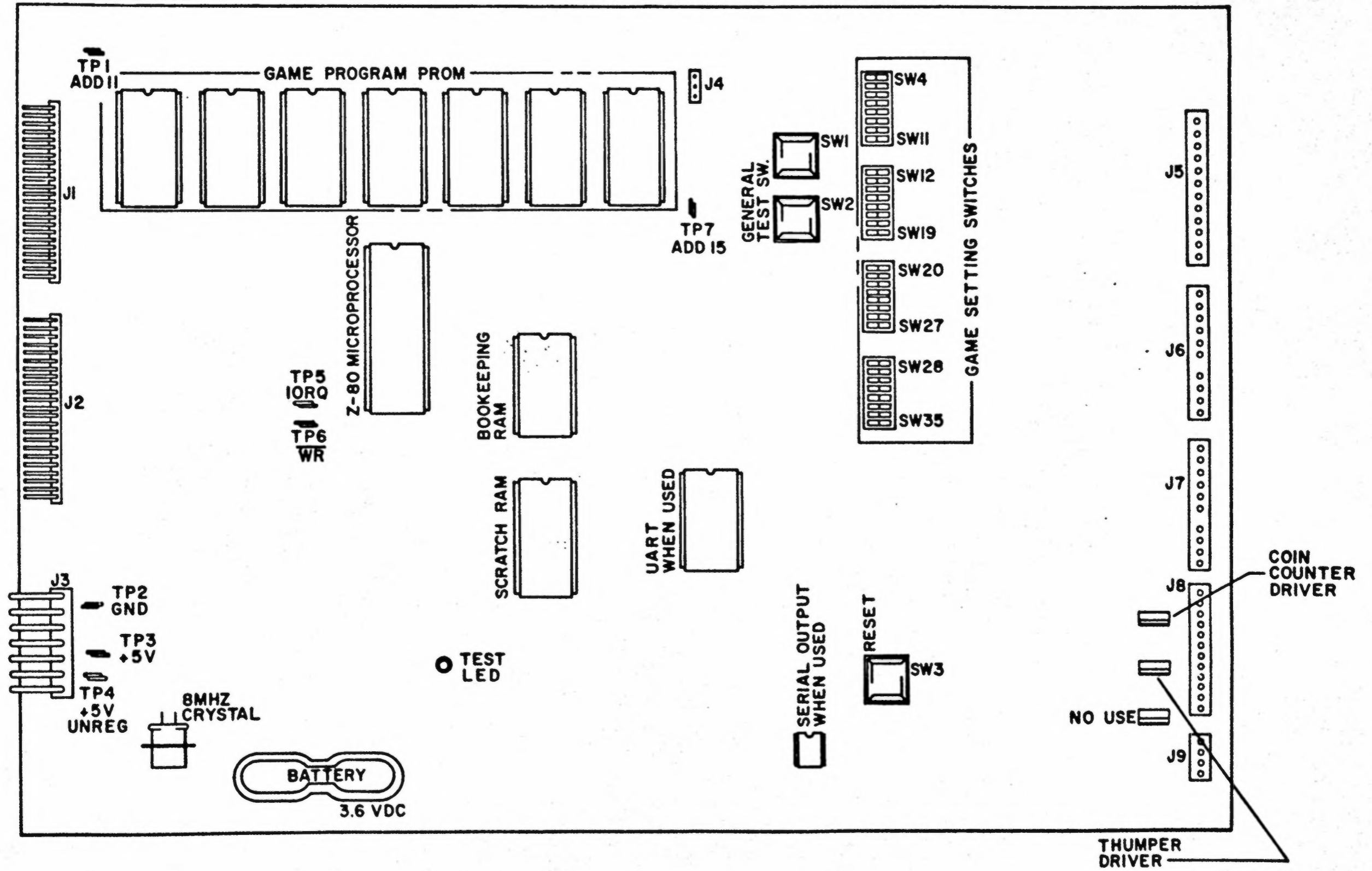

CFB-1000 P.C. BOARD

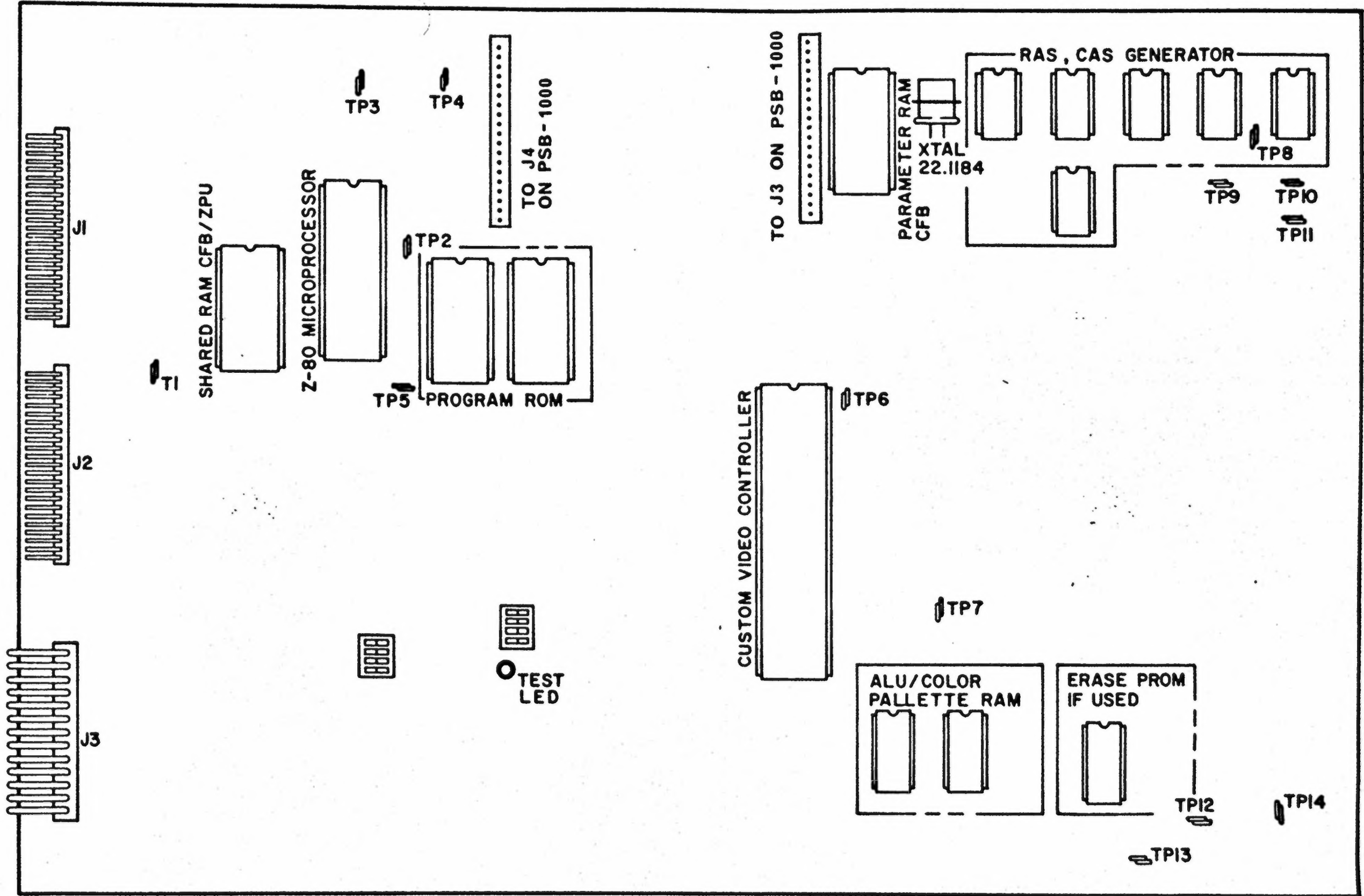

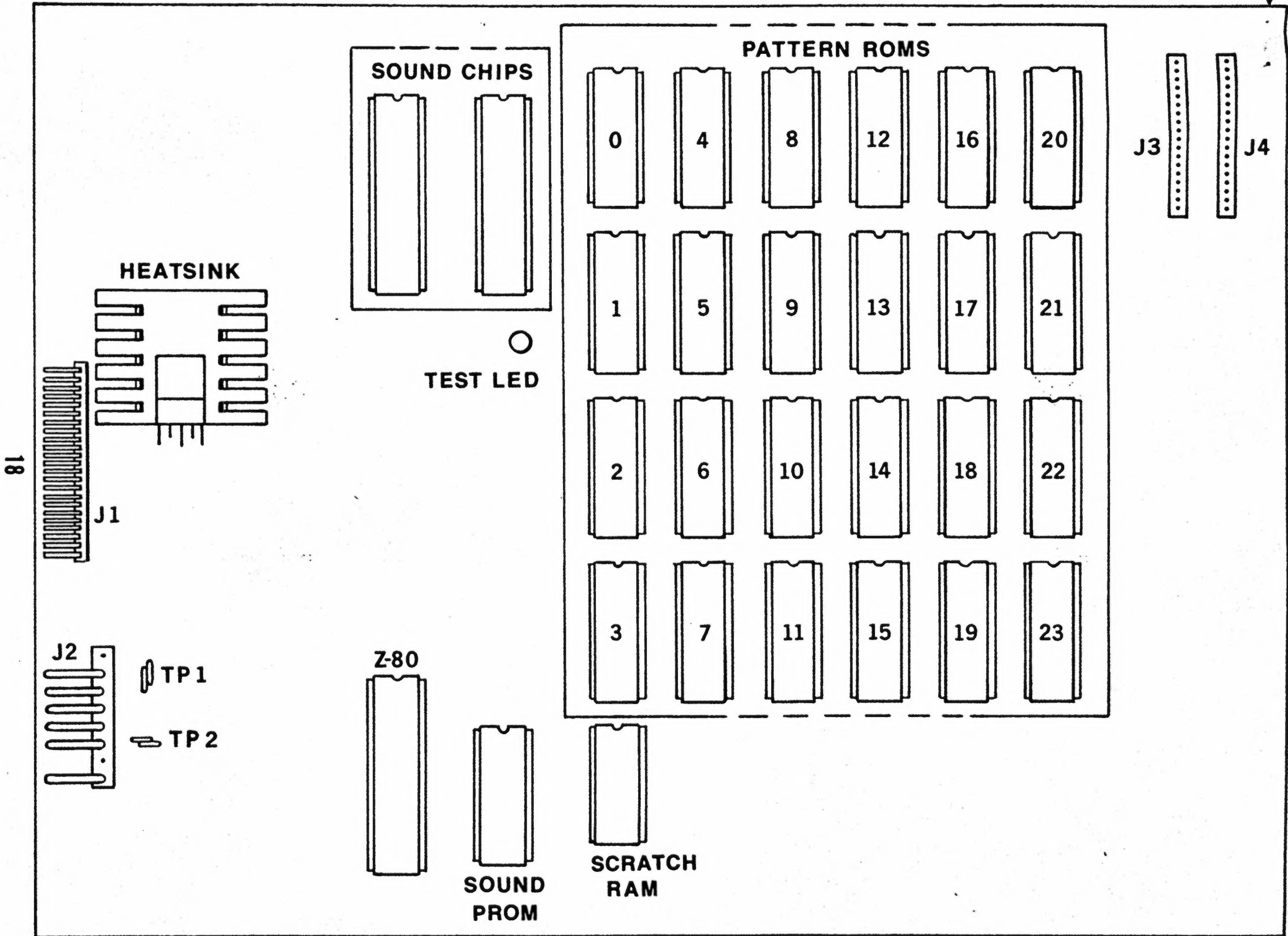

PS-1400 P.C.BOARD

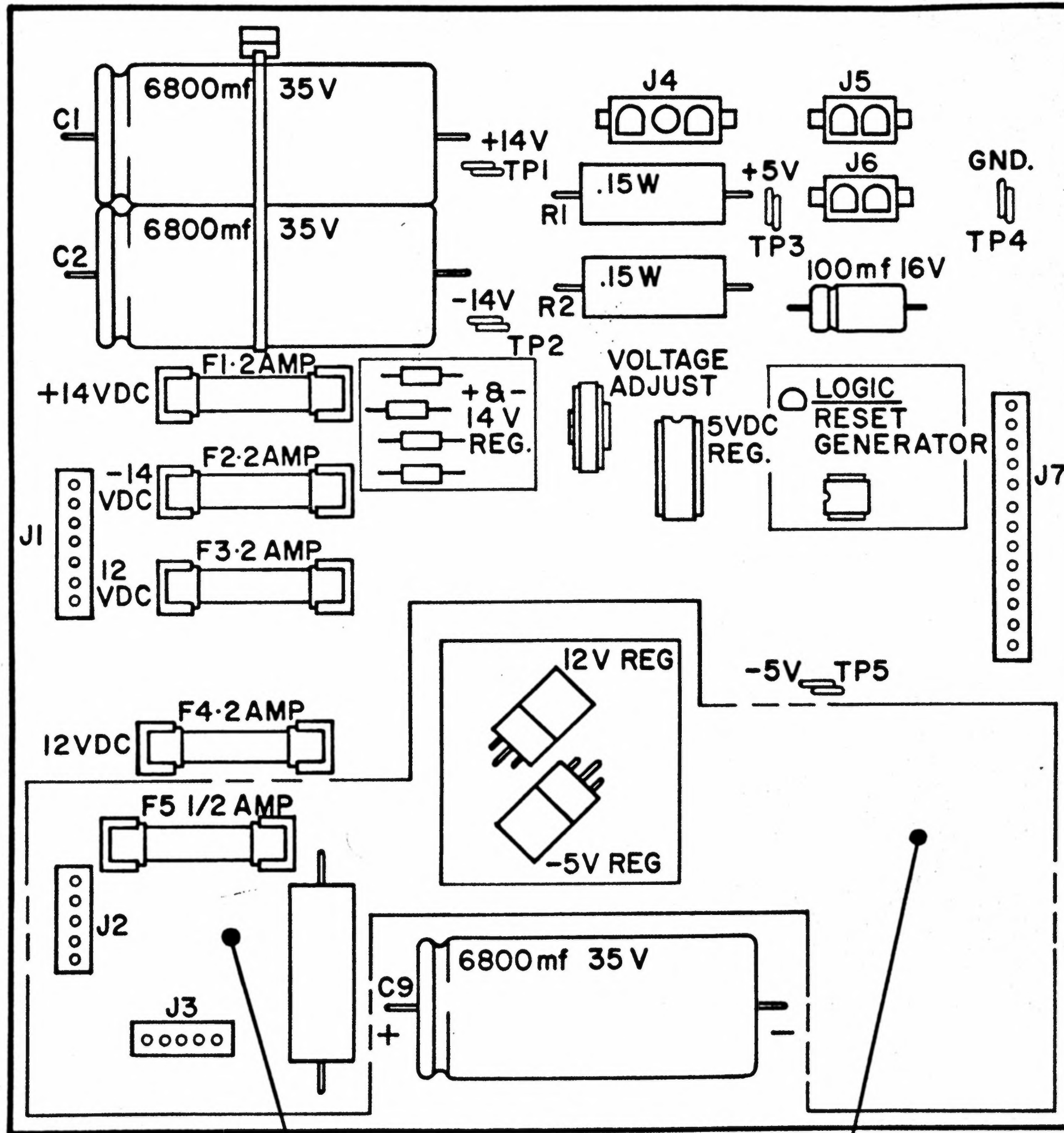

**THIS SECTION OF P.C.BOARD
NOT USED FOR GREAT GUNS**

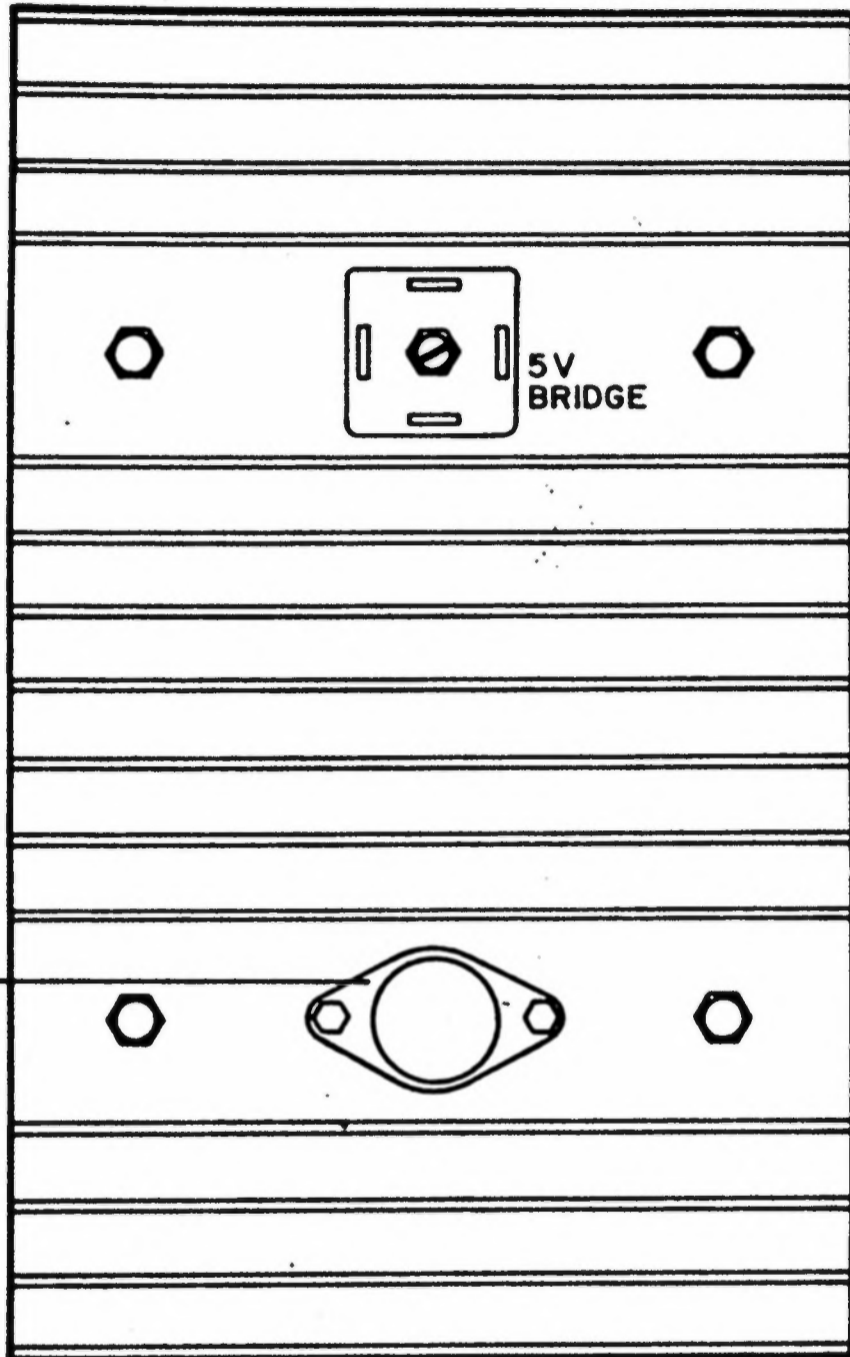

5V
VOLTAGE
REGULATOR

HEATSINK ASSY.

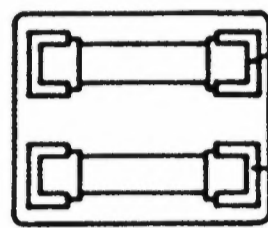

GEN. ILLUMINATION
FUSE 1 AMP

5V FUSE
(FOR REGULATOR)
10 AMP

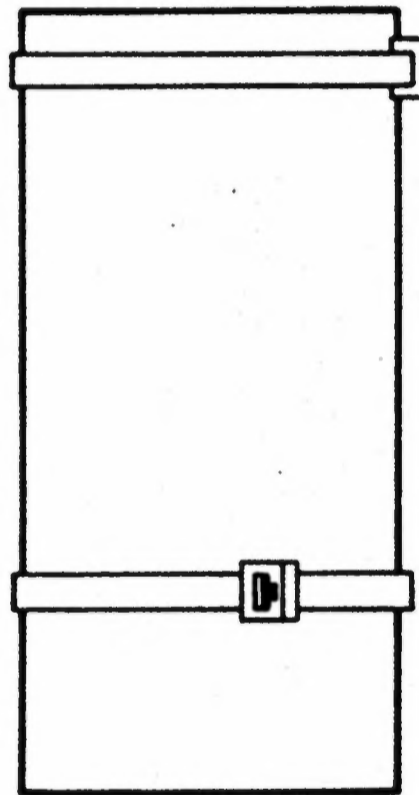

68000mf - 20V
CAPACITOR

