

meadows

**GYPSY
JUGGLER**
Manual tm

*To NORM
BELAM FL. CORP.*

Meadows Games, Inc.

181 Commercial Street

Sunnyvale, California 94086

Telephone (408) 732-8110
National Toll Free (800) 538-1606

GYPSY JUGGLER

tm

Manual

For Service/Instructions

MEADOWS GAMES INC.

GYPSY JUGGLER tm

TABLE OF CONTENTS

	PAGE(S)
1. GENERAL INTRODUCTION	1
11. NORMAL OPERATION AND GAME SEQUENCE	
A. ATTRACT MODE	1
B. COINS INSERTED	2
C. INSTRUCTION MODE	2
D. READY TO START JUGGLING	2-3
E. DROP AN EGG (MISS)	3
F. GAME OVER	3
111. SWITCHABLE OPTIONS	
A. COINS PER PLAYER	4
B. MISSES PER GAME	4
C. INTERMITTENT MUSIC DURING ATTRACT MODE	4
D. EXTENDED PLAY (EXTRA MISS)	4
IV. GYPSY JUGGLER CONTROL PANEL	
A. DESIGN	5
B. TO OPEN PANEL	5
C. TO REMOVE PANEL	5
D. TO REMOVE	
(1) PUSHBUTTONS	5
(2) SWITCHES	5
(3) POT CONTROL	5
V. REMOVE MONITOR	5-6
VI. REMOVE MICROPROCESSOR LOGIC BOARD	6
V11. REMOVE MICROPROCESSOR AUDIO BOARD	6

	<u>PAGE(s)</u>
VIII. REMOVAL OF POWER SUPPLY	6
IX. REMOVAL OF ATTRACT PLEX	7
X. REMOVAL OF FRONT PLEX	7
XI. INTERLOCK SWITCH, FUNCTION OF:	7
XII. AUDIO ADJUSTMENTS	7
XIII. AUTOMATIC ROM/RAM SELF-TEST	7
XIV. OVERSEAS OPERATION - VOLTAGE REQUIREMENTS	8
XV. WARRANTY	8
RETURN AUTHORIZATION (RA) POLICY	8
<u>LIST OF ILLUSTRATIONS</u>	
SWITCHABLE OPTIONS, OPERATOR ADJUSTABLE	9
CABINET DRAWING, W/MARKED DESIGNATIONS	10
CABINET DRAWING, (FOR TV, PLEX, CONTROL PANEL LOCATIONS).	11
GAME SCHEMATICS	12
RECOMMENDED SPARE PARTS LIST	13
XVI. MOTOROLA SERVICE MANUAL	

"FREE PLAY" coin option specific design and purpose is to enable the game to be put into this mode for showroom demonstration or exhibit/trade show demonstration, and eliminating the necessity of having to leave the coin door open for access to the coin acceptor or affix an external free play button. When GYPSY JUGGLER is used in FREE PLAY, 4 game credits are always given. All 4 credits must be played before game will go back into attract mode.

Another feature included in the attract mode, (operator selectable), is one chorus of theme music, Thunder and Blazes a.k.a. (Entry of the Gladiators), which will play one chorus approximately every 4 minutes. One chorus lasts approximately 20 seconds. The volume for intermittent music during attract mode can be controlled and adjusted separately from the other sound effects that accompany the game during play.

B. COINS INSERTED

When coins have been inserted, GAME CREDITS will indicate the number of credits (i.e. = 01). A series of 3 "gong" sounds accompany insertion of each coin. The attract mode stops immediately as soon as the first coin is inserted, and the "Instruction" mode appears on the screen. The MISSES LEFT will also indicate the number of misses the game is set for by the operator, (i.e.= 5) (Can be set at 2 to 9 misses).

C. INSTRUCTION MODE

All information on the top quarter of the T.V. will remain. In the area where the juggler figure appeared, the processor will write:

SEE CONTROL PANEL FOR
INSTRUCTIONS

SCORE XXXXX FOR EXTENDED PLAY(*)

One chorus of The Volga Boatmen will play during the attract mode. One chorus lasts about 8 seconds. The instruction mode and 8 second chorus will be terminated immediately when PLAYERS button is pressed.

(*) EXTENDED PLAY message will appear during the attract mode only if the operator selects this feature. XXXXX indicates the minimum score to be achieved and is operator selectable at 5,000; 15,000; or 35,000 points per player. EXTENDED PLAY is one additional miss during that players turn.

D. READY TO START JUGGLING

As indicated on the control panel "INSTRUCTIONS", each player must press "PLAYERS" button. When the players press PLAYERS button, 00000 is displayed to the corresponding players in a very rapid succession and

this procedure, too, is accompanied with sound effects. Putting players into play is accomplished in exactly the same manner as pinballs.

Player 1 score area begins to flash indicating Player 1 up. The Jugglers legs are moving and he can be moved freely left and right on the T.V. screen.

The player should locate the man directly under the chute and serve the first egg by pressing "ADD-ANOTHER-EGG" button. Juggling has begun by passing the egg from one hand to the other. For the first egg, each time the egg is juggled from one hand to the other, 5 points are added to the players score.

When the second egg is added by pressing "ADD-ANOTHER-EGG" button each successful hit adds 50 points to the players score. Please note that for best results and higher scores, each time one egg is added, the Juggler figure should be under chute. For the third egg put into play, each hit is worth 100 points; forth egg in play and hit is worth 200 points every time successfully juggled from hand to hand.

E. DROP AN EGG

When an egg is dropped (MISS), there is an accompanying "splat" sound. A chicken pops forth out of the egg and goes "peeping" off the screen in the shortest direction. The broken egg from which the chicken emerged remains visible on the screen until the next player "ADDS-AN-EGG" and starts juggling.

For each miss, the "MISSES LEFT" decreases by one. "NEXT PLAYER" is also written across the T.V. screen. These events occur until all "misses" are used up by the players.

F. GAME OVER

After all players have used the designated number of misses, "GAME OVER" is written across the T.V. screen and remains written on the screen for about four seconds. The game will automatically play one chorus of "Thunder and Blazes". "GAME OVER" message will disappear from the T.V. after the four second period and then the game will automatically go into the attract mode.

If a game credit remains on the game after "GAME OVER", the game will sequence its four second message and music for "GAME OVER" and then instantly go into Instruction Mode, playing its one chorus of The Volga Boatman.

All scoring information remains on playfield at completion of game if all credits are used. If credit(s) remain at completion of games just played, all information is eliminated except TODAY'S HI SCORE and GAME CREDITS.

III. SWITCHABLE OPTIONS (See Page 9)

A. COINS PER PLAYER

<u>COINAGE</u>	<u>SW4</u>	<u>SW5</u>
1 coin per player	ON	ON
1 coin = 2 player	OFF	ON
2 coins per player	ON	OFF
FREE PLAY	OFF	OFF

B. MISSES PER GAME

<u>#MISSES</u>	<u>SW1</u>	<u>SW2</u>	<u>SW3</u>
2	ON	ON	ON
3	OFF	ON	ON
4	ON	OFF	ON
5	OFF	OFF	ON
6	ON	ON	OFF
7	OFF	ON	OFF
8	ON	OFF	OFF
9	OFF	OFF	OFF

C. INTERMITTENT MUSIC DURING ATTRACT

	<u>SW6</u>
ON	OFF
OFF	ON

D. EXTENDED PLAY (EXTRA MISS)

	<u>SW7</u>	<u>SW8</u>
NO EXTENDED PLAY	ON	ON
5,000	OFF	ON
15,000	ON	OFF
35,000	OFF	OFF

If extended play is selected by the operator, this will be indicated to the player during the "Instruction Mode". To reiterate, the extended play message during Instruction Mode reads: "SCORE XXXXX FOR EXTENDED PLAY"; (XXXXX being the level of score the operator has chosen from D. above).

When the player reaches this score level while playing the game, a series of "gongs" will be heard and the message "SAME PLAYER PLAYS AGAIN" will be written in the solid yellow area under the juggler constantly until a "miss" occurs during that play. When the egg is dropped the egg splats; the chicken exits the T.V. screen and the identical message "SAME PLAYER PLAYS AGAIN" is written again across the middle of the T.V. The extended play is therefore indicated in "MISSES LEFT" area and does not decrease by one. For instance, if "MISSES LEFT" shows 3 and extended play is reached, "MISSES LEFT" will still indicate 3 at the end of that players turn. Additionally the player number (1,2,3, or 4) will continue to flash as further reminder that it is still this players turn.

IV. GYPSY JUGGLER CONTROL PANEL

A. DESIGN

GYPSY JUGGLER control panel has (2) pushbuttons and (1) clutch potentiometer (pot) control knob. One pushbutton, PLAYERS, is for putting the number of players into the game. The other pushbutton, "ADD-ANOTHER-EGG" is used for the purpose of adding eggs to be juggled to the juggler. The clutch pot control is designed to move the juggler from left to right on the T.V. screen.

The control panel is covered with MEADOWS new " texture-tuf, scratch resist, perma-print control panel".

B. TO OPEN PANEL

Unlock and open coin door. Reach through coin door and remove wing nut and washer from the left and right side of the control panel. Pull panel : out from front plex. Panel is hinged to the cabinet and therefore has a built-in 'stop' when flipped out from the cabinet.

C. TO REMOVE PANEL

To remove the panel, follow procedure described in B above. Removal, however, should not be necessary. When the panel is open, remove all wiring from the (3) switches and tuck the wiring back inside the cabinet to keep out of your way. Remove hex nuts, washers and carriage bolts from back side of hinges. The complete panel can now be removed.

D. TO REMOVE PUSHBUTTONS, SWITCHES, POT CONTROL

(1) Pushbuttons (MEADOWS p/n 051-0029)

With panel open, disconnect switch. Remove large nut from back of pushbutton. Remove pushbutton by lifting off from top of control panel.

(2) Switches Cherry p/n E2350K (MEADOWS p/n 051-0016)

Disconnect switch. Remove (2) 4-40 hex nuts, washers and machine screws. Remove switch and replace.

(3) Pot Control (MEADOWS p/n 043-0014)

Pot Control is a 5K clutch pot. With the control panel in closed position, remove Black knob (MEADOWS p/n 091-0070) with a small screwdriver or hex driver, as applicable. Now open control panel and remove (3) wires. Using your fingers, grasp pot firmly and from the outside surface of the control panel, remove the nut and washer from the pot with the use of pliers or nut driver.

V. TO REMOVE MONITOR

1. Turn ON/OFF TOGGLE SWITCH located on top back of cabinet to "OFF". (See pg. 12)
2. Disconnect power cord from AC outlet.
3. Remove cabinet back door.

4. Remove and set aside (4) hex nuts and washer from underside of wooden TV mounting shelf.
5. Remove (4) carriage bolts from shelf.
6. Remove front plex. (Refer to page 7).
7. Remove nuts and machine screws from each upper corner of TV chassis brace mounted into wooden support blocks.
8. Grasp frame and TV firmly with both hands and remove TV from front of cabinet opening.

SPECIAL NOTE:

Manufacturer recommends front removal of TV; however, TV can be removed through back door.

VI. TO REMOVE MICROPROCESSOR LOGIC BOARD

1. Turn ON/OFF toggle switch located on top back of cabinet to "OFF".
2. Disconnect power cord from AC outlet.
3. Remove back door of cabinet.
4. Logic board is located on the right side of the cabinet as seen from the back door. Remove #6 sheet metal screw.
5. Disconnect (2) edge connectors.
6. Slide board out from slotted cleat.

VII. TO REMOVE MICROPROCESSOR AUDIO BOARD

1. Turn ON/OFF toggle switch located on top back of cabinet to "OFF".
2. Disconnect power cord from AC outlet.
3. Remove back door of cabinet.
4. Audio board is the smaller board located on the left side of cabinet as seen from back door. Remove #6 sheet metal screw.
5. Disconnect (2) edge connectors.
6. Slide board out from slotted cleat.

VIII. REMOVAL OF POWER SUPPLY (IF NECESSARY)

1. Turn ON/OFF toggle switch located on top back of cabinet to "OFF".
2. Disconnect power cord from AC outlet.
3. Remove cabinet back door.
4. Power supply is located on the floor of the cabinet.
5. Disconnect male and female 9-pin Molex connector that connects the power supply and main harness.

NOTE: DO NOT REMOVE 115/230V converter plug.

6. Remove (4) sheet metal screws located at each corner of this assembly.
7. Remove from cabinet.
8. Refer to schematics for service. (Page 14).

IX. REMOVAL OF ATTRACT PLEX

1. Open cabinet back door.
2. Located on inside ceiling of cabinet, find 1/2" wide, flat security bar.
3. Loosen slightly the Phillips screw, (suggest 1/4 turn).
4. Pull straight back on security bar releasing attract plex.
5. Move to front of cabinet and carefully lift plex out from cabinet. (A small screwdriver can be used for removal, or plex can be removed without the use of tools - by hand).

X. REMOVAL OF FRONT PLEX

1. Open control panel. (See Section IV., B., Page 5).
2. Push "up" on lower center of plex.
3. Remove by pulling up and forward on plex.

XI. INTERLOCK SWITCH, FUNCTION OF: (Inside Back Door)

1. Door ON, game powered, provided plugged into AC outlet.
2. Door OFF, AC power automatically shut off.
3. To service or troubleshoot game when back door removed, pull Interlock Switch OUT to fullest extension.

XII. AUDIO ADJUSTMENT

GYPSY JUGGLER has two (2) volume control pots (found on the Audio PCB) to regulate the game play sounds from the music sounds during ATTRACT MODE. Please refer to Page 10 for location and function of volume controls.

XIII. AUTOMATIC ROM/RAM SELF-TEST

Upon powering up GYPSY JUGGLER, the microprocessor will clear the screen to all white (not visible if monitor is not warm), which will show any defects in the screen display circuitry. After about one or two seconds, the microprocessor will attempt to exercise the "RAM" circuits. If there is a failure in the RAM, the screen will flash "RAM FAILED" in a dark rectangle in the center of the TV, and then the microprocessor will begin the automatic ROM/RAM test all over again.

If the RAM's are good, then the microprocessor will examine all of the program ROM's to verify they are working and that the program is good. If the ROM test fails, the words "ROM FAILED" will flash on the TV in a dark rectangle in the center of the screen, and the automatic ROM/RAM test will be started over again.

Due to warm-up time, the RAM's or ROM's may fail to pass the automatic ROM/RAM test once or twice. If this happens and the game starts normally, then the failure was temporary. If there is a 'real' failure, the words in the rectangle will continue to flash indefinitely.

XIV. OVERSEAS OPERATION - VOLTAGE REQUIREMENTS

For overseas operation of GYPSY JUGGLER requiring operation at other than 115V, please refer to:

1. TV monitor - slide switch located on bottom left side marked: "VOLTAGE". (See MOTOROLA SERVICE MANUAL, Section XVI).
2. Nine-pin connection located at power supply on cabinet floor. Make connection at end labeled 230V.
3. On models built by the manufacturer for overseas operation, an additional "Step-Down Transformer" has been installed between the AC power cord and the light fixture. If you plan to ship your game to a location where 230V only is available, a Step-Down Transformer is REQUIRED. DO NOT attempt to power up at 230V without a transformer. If you need this transformer, a Stancore, P/N P6820, or equivalent, (MEADOWS P/N 050-0017) can be used.

XV. WARRANTY

Contact the distributor from whom your game was purchased for warranty and/or service information.

NOTE:

ALL EQUIPMENT RETURNED TO THE FACTORY MUST HAVE A RETURN AUTHORIZATION NUMBER, ISSUED BY MEADOWS GAMES, INC., AND TRAVEL FREIGHT PREPAID. TO ASSIST YOURSELF IN EXPEDITING THE RETURN OF ANY ITEM TO BE SERVICED, PLEASE BRIEFLY LIST SYMPTOMS OF MALFUNCTION. YOUR COOPERATION IS GREATLY APPRECIATED.

GOOD LUCK AND ENJOY THE MANY PROFITS OF OWNING AND OPERATING ----
MEADOWS GAMES "GYPSY JUGGLER".

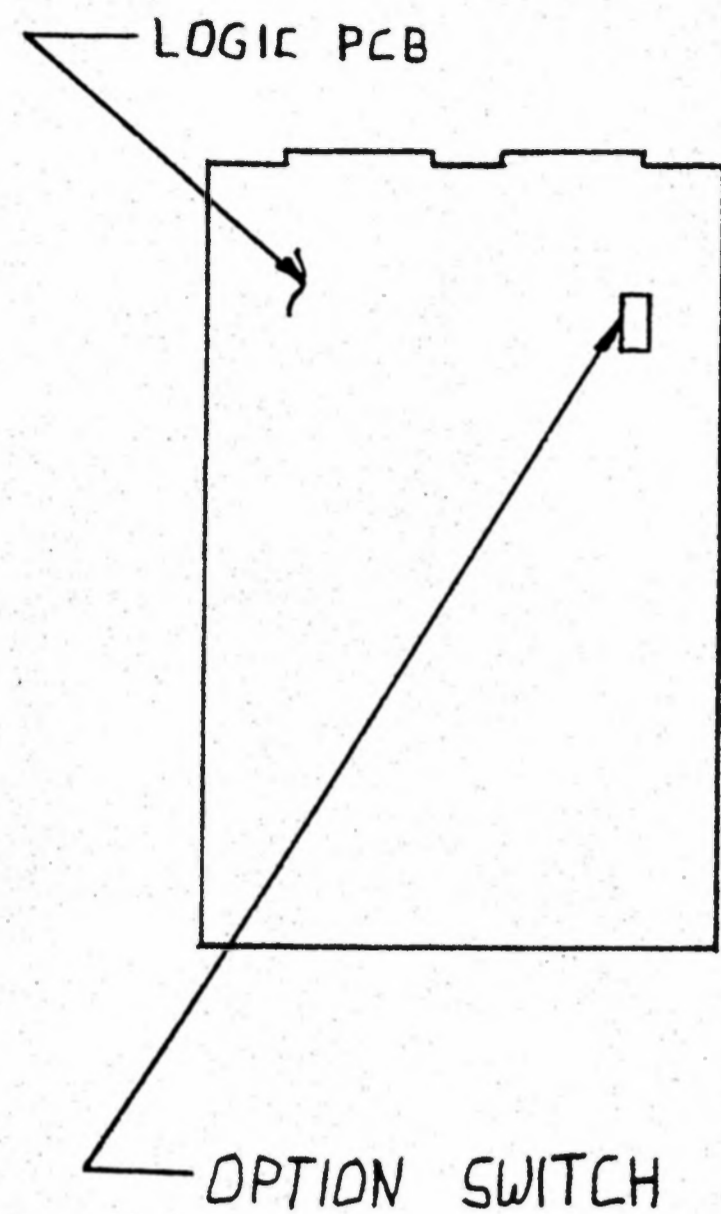

	2	3	4	5	6	7	8	9
MISS OPTION 1	ON	OFF	ON	OFF	ON	OFF	ON	OFF
MISS OPTION 2	ON	ON	OFF	OFF	ON	ON	OFF	OFF
MISS OPTION 3	ON	ON	ON	ON	OFF	OFF	OFF	OFF

	1 COIN PER PLAYER	1 COIN 2 PLAYERS	2 COINS 1 PLAYER	FREE
COIN OPTION 4	ON	OFF	ON	OFF
COIN OPTION 5	ON	ON	OFF	OFF

	ON	OFF
MUSIC (ATTRACT) 6	OFF	ON

NONE 5000 15,000 35,000

EXTENDED PLAY OPTION 7	ON	OFF	ON	OFF
EXTENDED PLAY OPTION 8	ON	ON	OFF	OFF

GYPSY JUGGLER™
OPERATOR SELECTION
SWITCH OPTIONS

MEADOWS GAMES, INC.

DWN	5/25/78	D.MAL McCANN
APP		

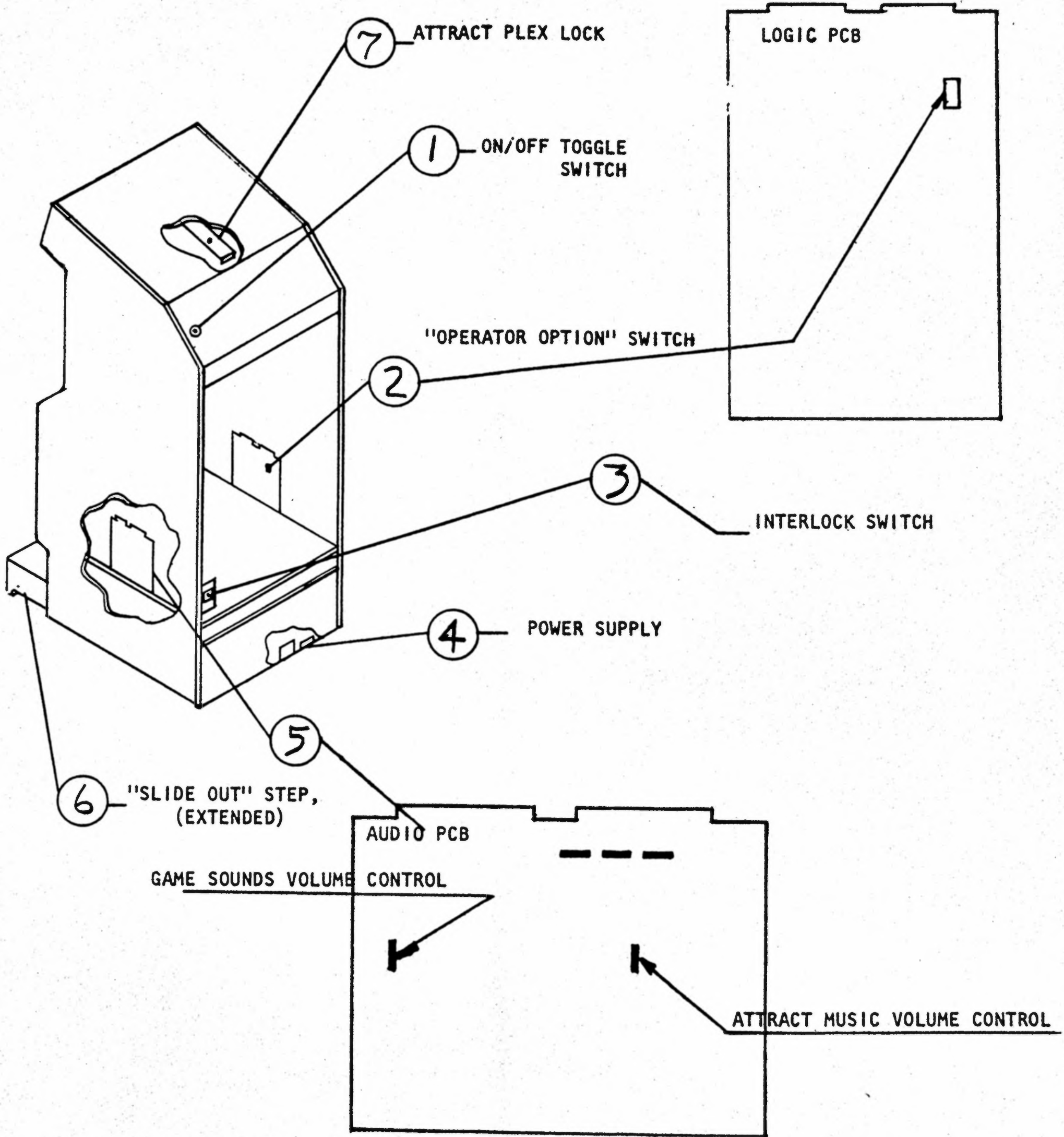

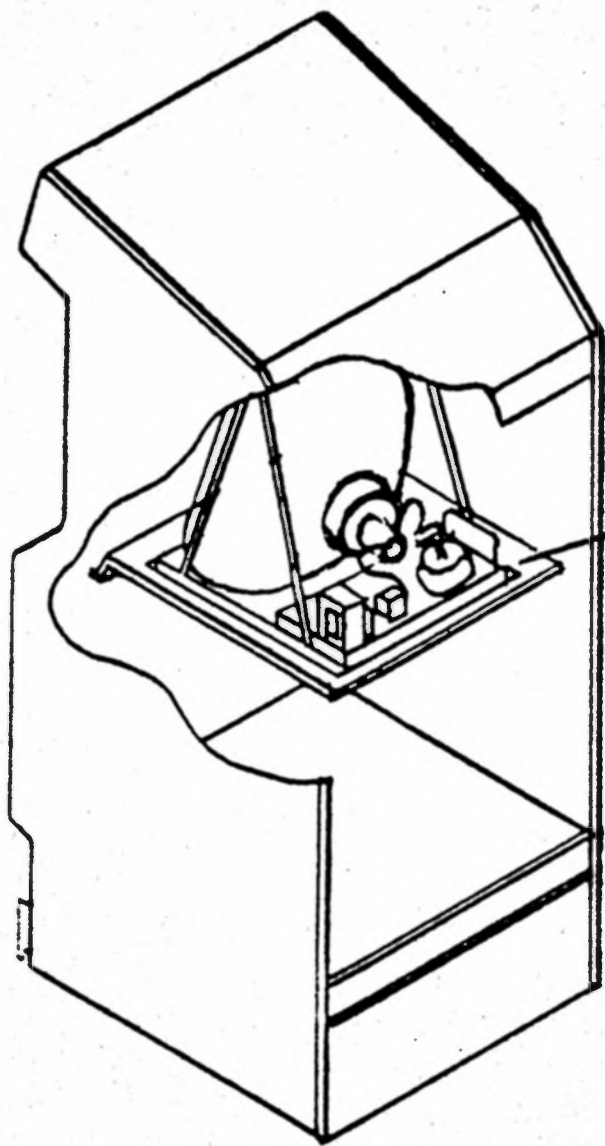

MOTOROLA MONITOR

ATTRACT PLEXIGLASS

TV PLEXIGLASS

CONTROL PANEL

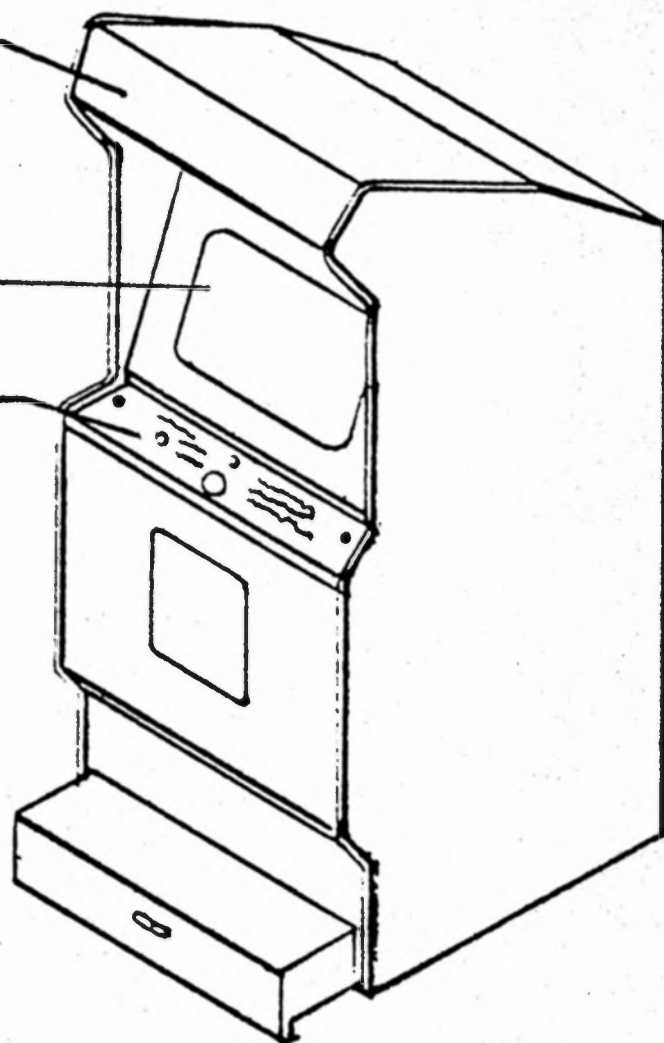

REVISIONS			
LTR	ZONE	DESCRIPTION	BT/DATE

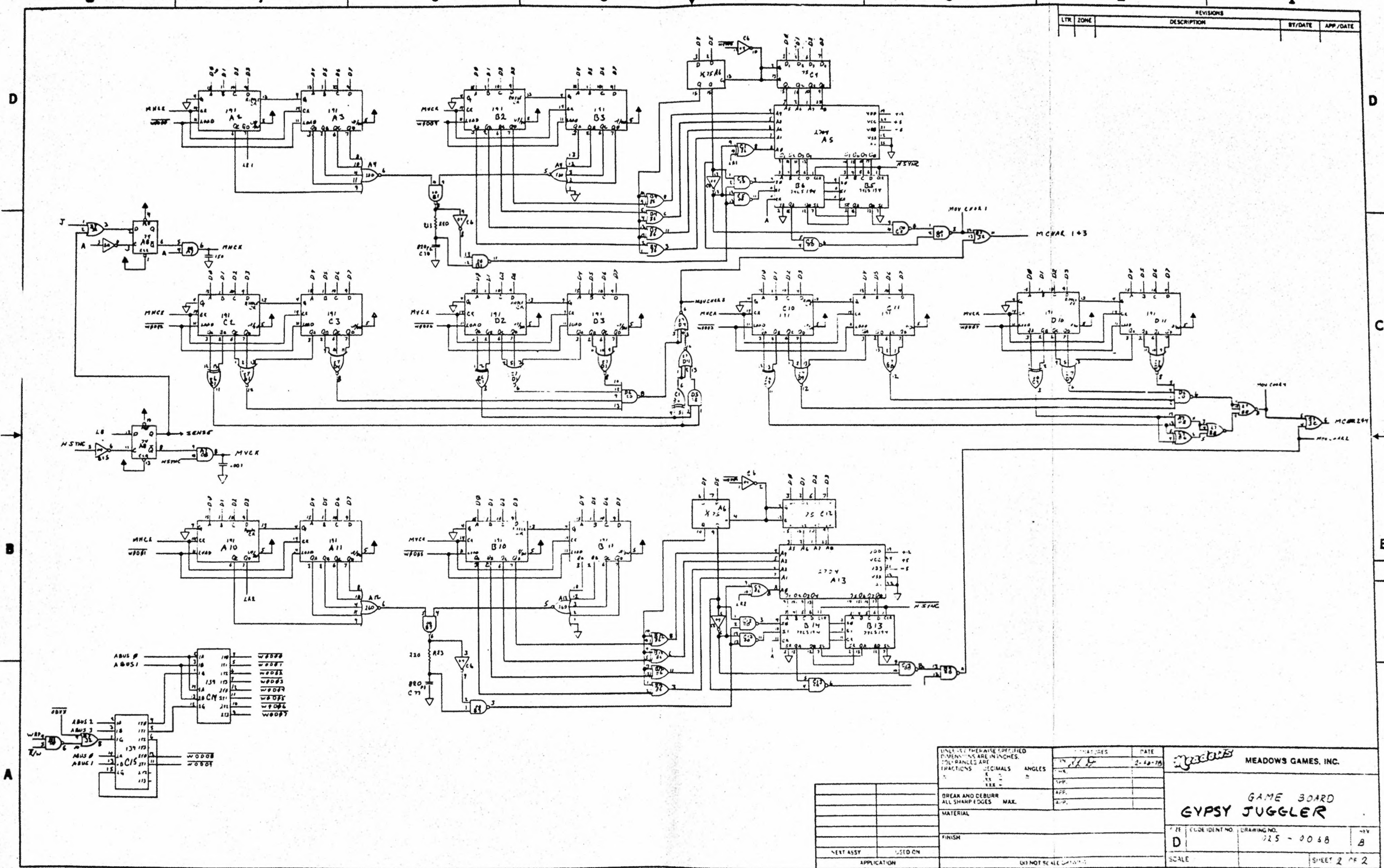

DIMENSIONS SPECIFIED DIMENSIONS ARE IN INCHES. TOLERANCES ARE: FRACTIONS DECIMALS ANGLES	SIGNATURES DATE <i>[Signature]</i> 2-10-78 APP. DATE APP. DATE	MEADOWS GAMES, INC. GYPSY JUGGLER CLD IDENT NO. DRAWING NO. 725-0048 SCALE SHEET 2 OF 2
BREAK AND DEBURR ALL SHARP EDGES MAX.	MATERIAL FINISH NEXT ASSY USED ON APPLICATION	UNLESS OTHERWISE SPECIFIED DIMENSIONS ARE IN INCHES. TOLERANCES ARE: FRACTIONS DECIMALS ANGLES

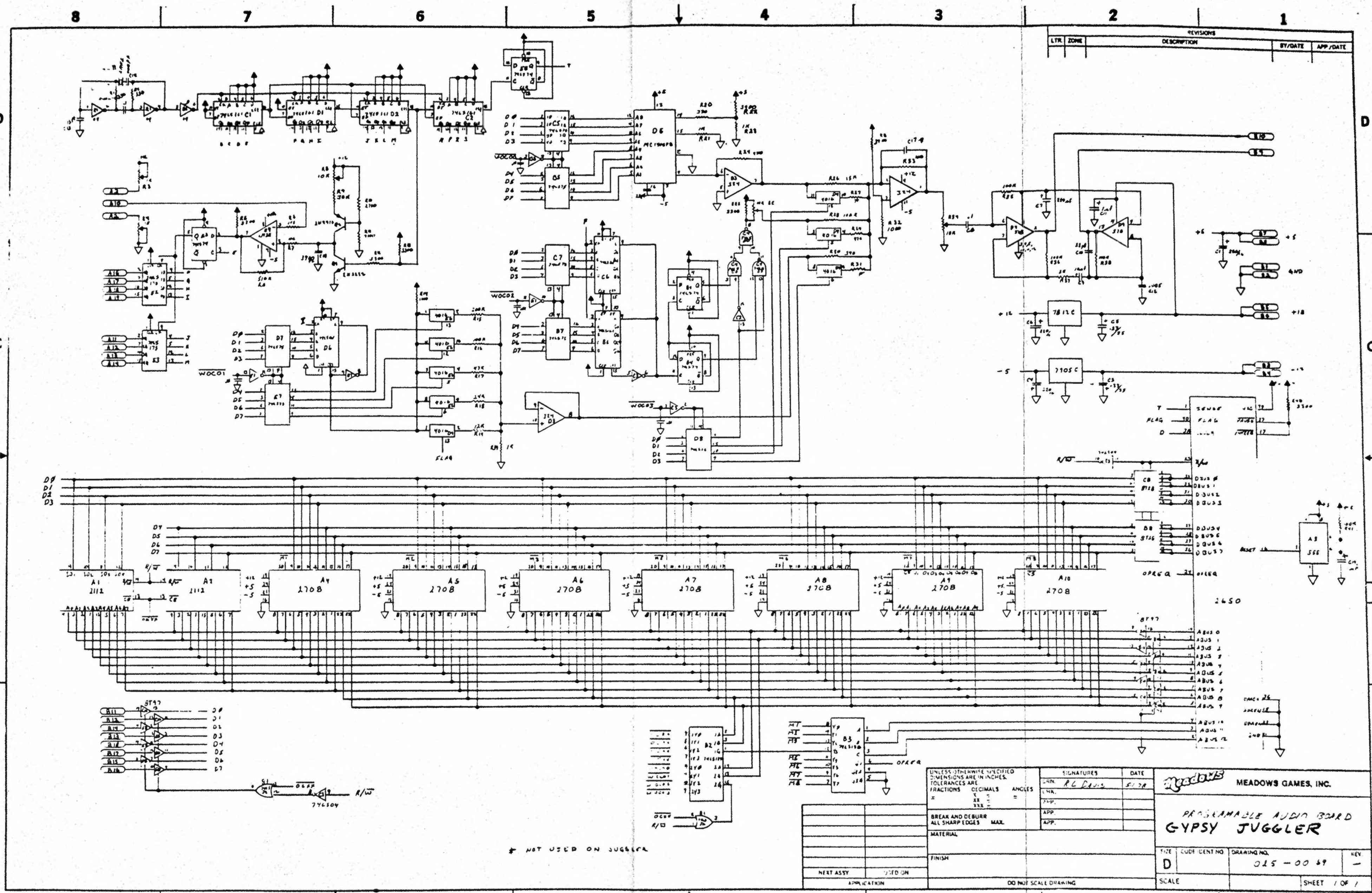

REVISIONS			
LTR. ZONE	DESCRIPTION	BY/DATE	APP/DATE

UNLESS OTHERWISE SPECIFIED DIMENSIONS ARE IN INCHES. TOLERANCES ARE	SIGNATURES	DATE
FRACTIONS DECIMALS ANGLES	CHK. <i>RC Davis</i>	5/78
	APP.	
BREAK AND DEBURR ALL SHARP EDGES	APP.	
MATERIAL		
FINISH		
NEXT ASSY	USED ON	
APPLICATION		

MEADOWS GAMES, INC.		
PROGRAMMABLE AUDIO BOARD GYPSY JUGGLER		
SIZE	CODE IDENT NO	DRAWING NO.
D		015-00 59
SCALE		SHEET 1 OF 1

* NOT USED ON JUGGLER

GYPSY JUGGLER SPARES LIST
t.m.

PART NUMBER	DESCRIPTION	PART NUMBER	DESCRIPTION
012-0012	Coin Counter Assy	051-0026	ON/OFF Switch
012-0175	Coin Door Assy	051-0028	Interlock Switch
012-0176	Control Panel Assy	058-0020	Florescent Lamp
014-0036	Cardboard Bezel	067-0008	Speaker
014-0054	Speaker Screen	095-0001	Lock Set
014-0007	Lock Bracket	095-0016	Lock Cam
014-0510	Coin Box	097-0020	Manual
014-0511	Coin Box Lid	023-0070	Power Supply
014-0553	Plex Latch	050-0017	115/230V Transformer
014-0554	Panel Latch	013-0168	Wood Spacer (Panel)
014-0555	Bracket Interlock	014-0566	Switch Bracket (Panel)
016-0120	25¢ Sticker	051-0016	Switch (Panel)
016-0121	Warning Label	016-0133	Panel Overlay Texter-Tuf
016-0131	Front Plex	051-0029	Red Pushbutton
016-0132	Attract Plex	043-0014	5K Potentiometer
023-0068	Logic PCB	091-0070	Black Control Knob
023-0069	Sound PCB	085-0031	Panel Hinge
027-0066	Power/Light Harness		
027-0063	Ground Harness		
027-0067	115/230 Volt Adapter		
027-0065	Main Harness		



MOTOROLA

Service Manual

VP 24

DATA PRODUCTS

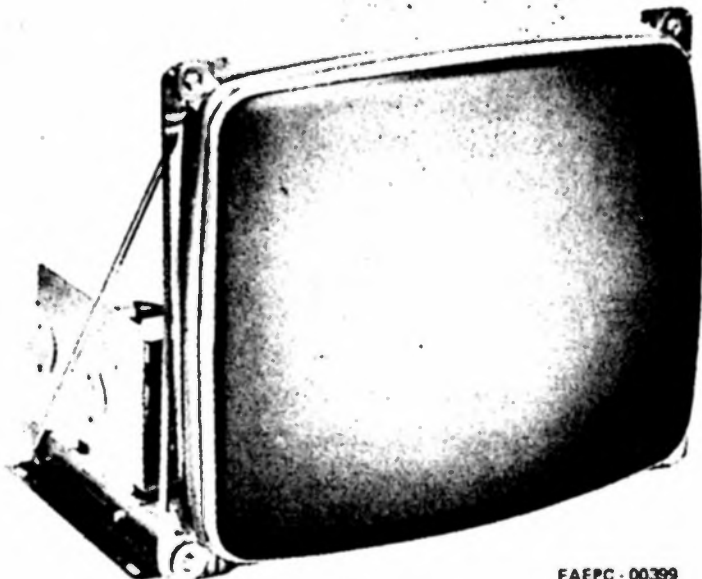

FAEPC-00399

Model M5000/M7000 Series Monitor

CAUTION

NO WORK SHOULD BE ATTEMPTED ON ANY EXPOSED MONITOR CHASSIS BY ANYONE NOT FAMILIAR WITH SERVICING PROCEDURES AND PRECAUTIONS.

GENERAL INFORMATION

This manual contains information on the M5000/M7000 monitor series, the optional KV800A audio module, and the +5 volt logic power supply. The M5000/M5010 series use a 19-inch CRT and the M7000/M7010 series use a 23-inch CRT. All CRT's are of the magnetic deflection type with integral implosion protection.

The M5010/M7010 series incorporates the adjustable +5 volt logic supply for external logic circuitry, and the optional audio module. The monitor series is capable of providing power for external audio modules to reproduce monaural or stereo sound. The monaural and stereo input signals are applied to the 12-pin connector located at the rear of the chassis. A 3-pin output connector is provided at the rear of the chassis for each audio module.

All monitor power supplies are capable of producing both +73 volts and +12 volts regulated from either 115

MODELS
M5000-155
M7000-155
M5010-155
M7010-155
KV800A-AUDIO MODULE*

* AVAILABLE OPTION

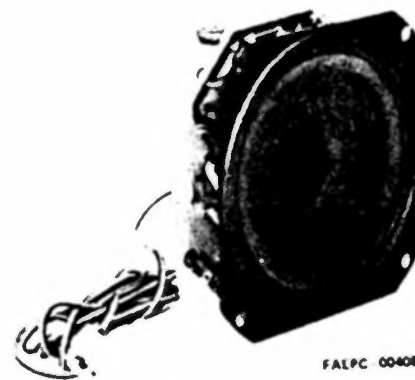

FALPC 00408

KV800A - Audio Module*

volt or 230 volt AC input to the transformer primary. All monitor variations described herein require a composite video input signal.

Input and output connections for the monitors are made through a 12-pin connector plug located at the rear of the chassis. Inputs consist of composite video, audio, and 115/220 volt AC three-wire. The outputs consist of +5 volts regulated (12-pin connector), and +73 volts regulated and audio (3-pin connector).

All monitors employ: four stages of video amplification, a two-stage sync separator, a two-stage vertical integrator, a four-stage horizontal sweep circuit, a three-stage vertical sweep circuit, a one-stage spot kill, a one-stage blanking amplifier; and a regulated, full-wave bridge, power supply. The table below describes the associated functions and optional equipment that is available for each monitor.

MODEL BREAKDOWN CHART

MODEL	VIDEO INPUT	+5 VOLT SUPPLY (FACTORY OPTION)	KV800A (AVAILABLE OPTION)	19" CRT	23" CRT
M5000-155	COMPOSITE			X	
M5010-155	COMPOSITE	X	X	X	
M7000-155	COMPOSITE				X
M7010-155	COMPOSITE	X	X		X



MOTOROLA Data Products

CAROL STREAM, ILLINOIS 60187

PART NO. 68P25253A47

6/77 PRICE \$2.20

COPYRIGHT 1977 BY MOTOROLA, INC.

PRINTED IN U.S.A.

SAFETY WARNING

CAUTION: NO WORK SHOULD BE ATTEMPTED ON AN EXPOSED MONITOR CHASSIS BY ANYONE NOT FAMILIAR WITH SERVICING PROCEDURES AND PRECAUTIONS.

1. **SAFETY PROCEDURES** should be developed by habit so that when the technician is rushed with repair work, he automatically takes precautions.

2. A **GOOD PRACTICE**, when working on any unit, is to first ground the chassis and to use only one hand when testing circuitry. This will avoid the possibility of carelessly putting one hand on chassis or ground and the other on an electrical connection which could cause a severe electrical shock.

3. Extreme care should be used in **HANDLING THE PICTURE TUBE** as rough handling may cause it to implode due to atmospheric pressure (14.7 lbs. per sq. in.). Do not nick or scratch glass or subject it to any undue pressure in removal or installation. When handling, safety goggles and heavy gloves should be worn for protection. Discharge picture tube by shorting the anode connection to chassis ground (not cabinet or other mounting parts). When discharging, go from ground to anode or use a well insulated piece of wire. When servicing or repairing the monitor, if the cathode ray tube is replaced by a type of tube other than that specified under the Motorola Part Number as original equipment in this Service Manual, then avoid prolonged exposure at close range to unshielded areas of the cathode ray tube. Possible danger of personal injury from unnecessary exposure to X-ray radiation may result.

4. An **ISOLATION TRANSFORMER** should always be used during the servicing of a unit whose chassis is connected to one side of the power line. Use a transformer of adequate power rating as this protects the serviceman from accidents resulting in personal injury from electrical shocks. It will also protect the chassis and its components from being damaged by accidental shorts of the circuitry that may be inadvertently introduced during the service operation.

5. Always **REPLACE PROTECTIVE DEVICES**, such as fishpaper, isolation resistors and capacitors and shields after working on the unit.

6. If the **HIGH VOLTAGE** is adjustable, it should always be **ADJUSTED** to the level recommended by the manufacturer. If the voltage is increased above the normal setting, exposure to unnecessary X-ray radiation could result. High voltage can accurately be measured with a high voltage meter connected from the anode lead to chassis.

7. **BEFORE RETURNING A SERVICED UNIT**, the service technician must thoroughly test the unit to be certain that it is completely safe to operate without danger of electrical shock. **DO NOT USE A LINE ISOLATION TRANSFORMER WHEN MAKING THIS TEST.**

In addition to practicing the basic and fundamental electrical safety rules, the following test, which is related to the minimum safety requirements of the Underwriters Laboratories should be performed by the service technician before any unit which has been serviced is returned.

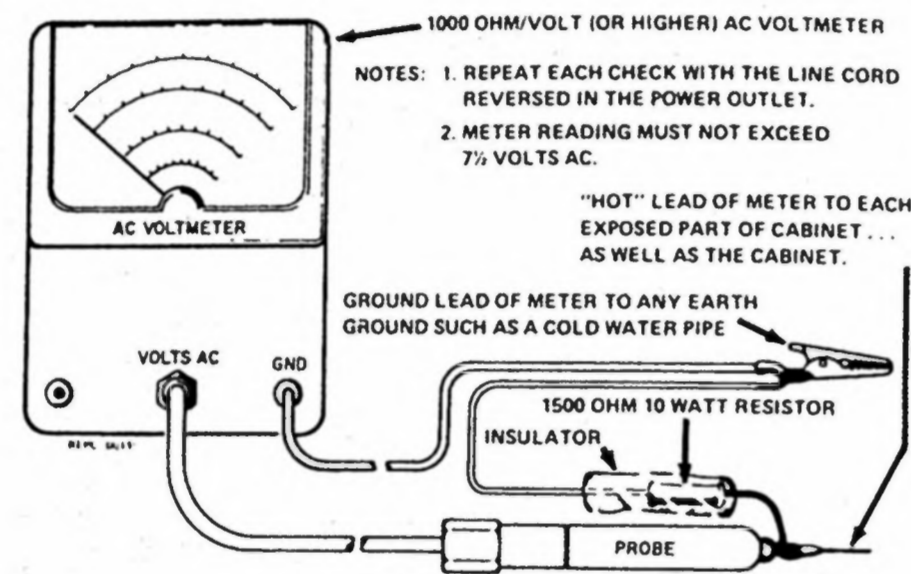

Voltmeter Hook-up for Safety Check

A 1000 ohm per volt AC voltmeter is prepared by shunting it with a 1500 ohm, 10 watt resistor. The safety test is made by contacting one meter probe to any portion of the unit exposed to the operator such as the cabinet trim, hardware, controls, knobs, etc., while the other probe is held in contact with a good "earth" ground such as a cold water pipe.

The AC voltage indicated by the meter may not exceed 7½ volts. A reading exceeding 7½ volts indicates that a potentially dangerous leakage path exists between the exposed portion of the unit and "earth" ground. Such a unit represents a potentially serious shock hazard to the operator.

The above test should be repeated with the power plug reversed, when applicable.

NEVER RETURN A MONITOR which does not pass the safety test until the fault has been located and corrected.

ELECTRICAL SPECIFICATIONS*

	MODELS: M5000-155/M5010-155	MODELS: M7000-155/M7010-155
PICTURE TUBE:	19" measured diagonally (48.2 cm); 184 sq. inch viewing area (1188 sq. cm); 114° deflection angle; integral implosion protection; P4 phosphor standard	23" measured diagonally (58.4 cm); 282 sq. inch viewing area (1820 sq. cm); 110° deflection angle; integral implosion protection; P4 phosphor standard
POWER INPUT:	115/230V AC, 110 Watts (nominal); 60 Hz provision for 230V AC, 50 Hz	
FUSES:	M5000-155, M7000-155 – 0.8A; M5010-155, M7010-155 – 1.0A	
+73 VOLT SUPPLY:	Electronically regulated over AC inputs from 103V AC to 130V AC, or 206V AC to 260V AC	
VIDEO INPUT:	0.5 Volts to 2.5 Volts P/P maximum, composite for 50V at CRT	
RESOLUTION:	500 lines at picture center	
LINEARITY:	Within 3%, measured with standard EIA ball chart and dot pattern	
HIGH VOLTAGE	17KV (nominal)	
HORIZONTAL BLANKING INTERVAL	11 microseconds typical (includes retrace and delay)	
SCANNING FREQUENCY:	Horizontal: 15,750 Hz ± 500 Hz; Vertical: 50/60 Hz	
ENVIRONMENT:	Operating temperature: 10 °C to 55° C (ambient) Storage Temperature: -40 °C to +65° C Operating Altitude: 10,000 ft. maximum (3048 meters) Designed to comply with applicable DHEW rules on X-Radiation CSA certified for use in coin-operated amusements in a combustible enclosure UL listed under specification 1410 (electronic components)	
TYPICAL DIMENSIONS:	14.11" H, 18.18" W, 14.83" D (35.8 x 46 x 37.6 cm)	16.72" H, 21.56" W, 16.18" D (42.4 x 54.7 x 41 cm)

AVAILABLE OPTIONS*

	+5 VOLT LOGIC SUPPLY
AC INPUT	Derived from separate winding in monitor power transformer.
DC INPUT	Derived from +73 volt output in monitor power supply for reference amplifier.
DC OUTPUT	+5V DC @ 3A adjustable, ± 5% regulation.

*Specifications subject to change without notice.

AVAILABLE OPTIONS*

KV800A AUDIO MODULE	
DC INPUT:	+73 volts required, supplied from M5010/M7010 series monitors or external power source.
AUDIO INPUT: (Each Channel)	0.5V for full output accessed through 12-pin connector.
AUDIO OUTPUT:	Linear 1.0 Watt (Nominal)
MECHANICAL:	4" PM speaker, integral volume control, 4 ft. cable (120 cm) provided for remote installation with M5010/M7010 series monitors.
ENVIRONMENT:	Operating temperature: 10°C to 55°C (ambient). Storage temperature: -40°C to +65°C. Operating altitude: 10,000 ft. maximum (3048 meters) CSA certified for use in coin-operated amusements in a combustible enclosure, UL listed under specification 1410 (electronic components).

* Specifications subject to change without notice.

SERVICE NOTES

CIRCUIT TRACING

Component reference numbers are printed on the top and bottom of the three circuit cards to facilitate circuit tracing. In addition, control names are also shown and referenced on the schematic diagram in this manual.

Transistor elements are identified as follows:

E — emitter, B—Base, and C— collector.

COMPONENT REMOVAL

Removing components from an etched circuit card is facilitated by the fact that the circuitry (copper foil) appears on one side of the circuit card only and the component leads are inserted straight through the holes and are not bent or crimped.

It is recommended that a solder extracting gun be used to aid in component removal. An iron with a temperature controlled heating element would be desirable since it would reduce the possibility of damaging the circuit card foil due to over-heating.

The nozzle of the solder extracting gun is inserted directly over the component lead and when sufficiently heated, the solder is drawn away leaving the lead free from the copper foil. This method is particularly suitable in removing multi-terminal components.

CRT REPLACEMENT

Use extreme care in handling the CRT as rough handling may cause it to implode due to high vacuum pressure. Do not nick or scratch glass or subject it to any undue pressure in removal or installation. Use goggles and heavy gloves for protection. In addition, be sure to disconnect the monitor from all external voltage sources.

1. Discharge CRT by shorting 2nd anode to ground; then remove the CRT socket, deflection yoke and 2nd anode lead.
2. Remove CRT from the front of the chassis by loosening and removing four screws; one in each corner of the CRT.

ADJUSTMENTS

A non-metallic tool is recommended when performing the following adjustments.

REGULATOR ADJUSTMENT

— NOTE —

Misadjustment of the +73 volt regulator, or the horizontal oscillator may result in damage to the horizontal output transistor or pulse limiter diode. The following procedure is recommended to insure reliable operation.

1. Connect the monitor to an AC line supply; then adjust supply to 120 volts (240 volts in some applications).
2. Apply test signal to proper input. Signal should be of same amplitude and sync rate as when monitor is in service.
3. Adjust HOR. SET coil L1 until display is stable.
4. Connect a DC digital voltmeter or equivalent precision voltmeter to the emitter of the regulator output transistor, Q17, or any +73 volt test point.
5. Adjust the 73V ADJUST. control, R93, for an output of +73 volts. DO NOT rotate the control through its entire range; damage to the monitor may result.
6. When adjustment is complete, the AC line supply can be varied between 103 and 130 volts AC to check for proper regulator operation. With the regulator operating properly, changes in display size should be negligible.

HORIZONTAL HOLD/OSCILLATOR ADJUSTMENT

Adjust the core of HOR. SET coil L1 until the horizontal blanking lines are vertical, or the CRT display is stable (synced).

+5 VOLT SUPPLY (OPTIONAL)

1. Connect the monitor to an AC line supply; then adjust supply to 120 volts (240 volts in some applications).
2. Connect a DC digital voltmeter or equivalent pre-

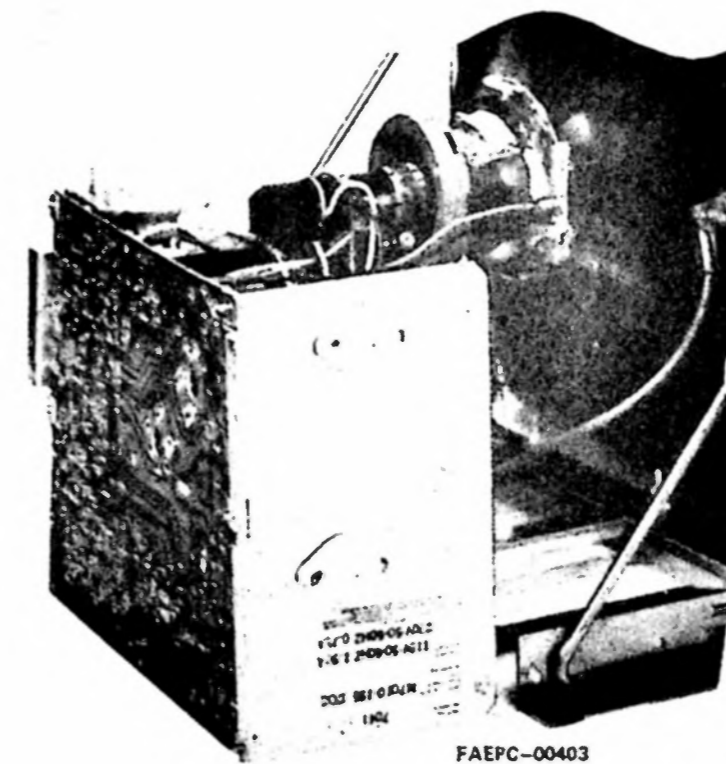

Monitor Circuit Board in Service Position

cision voltmeter to the emitter of the regulator output transistor, Q201, or any +5 volt test point.

3. Adjust the 5V adjust control, R206, for an output of +5 volts.
4. When adjustment is complete, the AC line supply can be varied between 103 and 130 volts AC to check for proper regulator operation.

VERTICAL HEIGHT/LINEARITY ADJUSTMENT

1. Connect a test generator whose output is similar to the display signal normally used.
2. Rotate the vert. size control, R60, until the smallest display is obtained.
3. Adjust the vert. lin. control, R64, until the top and bottom of the test pattern is equally spaced.
4. Re-adjust R60 until the desired display height is obtained.
5. Re-adjust R64, if necessary, as in Step 2 above.

FOCUS ADJUSTMENT

The best overall focus of the display is obtained by adjusting the focus control, R42, for best focus at a point which is near the center and approximately 1/3 down from the top of the display.

MONITOR SERVICING

The monitor circuit board or the +5 volt supply circuit card may be installed in a service position to provide easier access to the circuit foil when servicing the monitor (see views below).

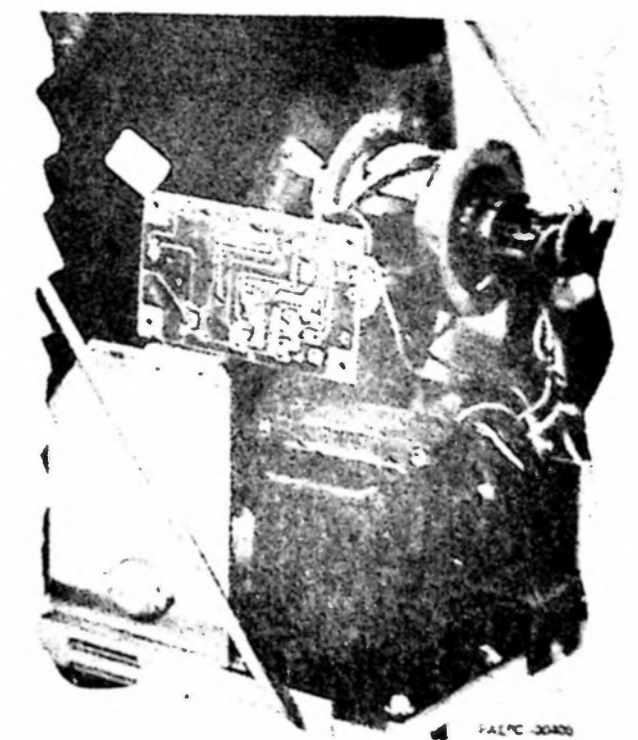

+5 Volt Supply in Service Position

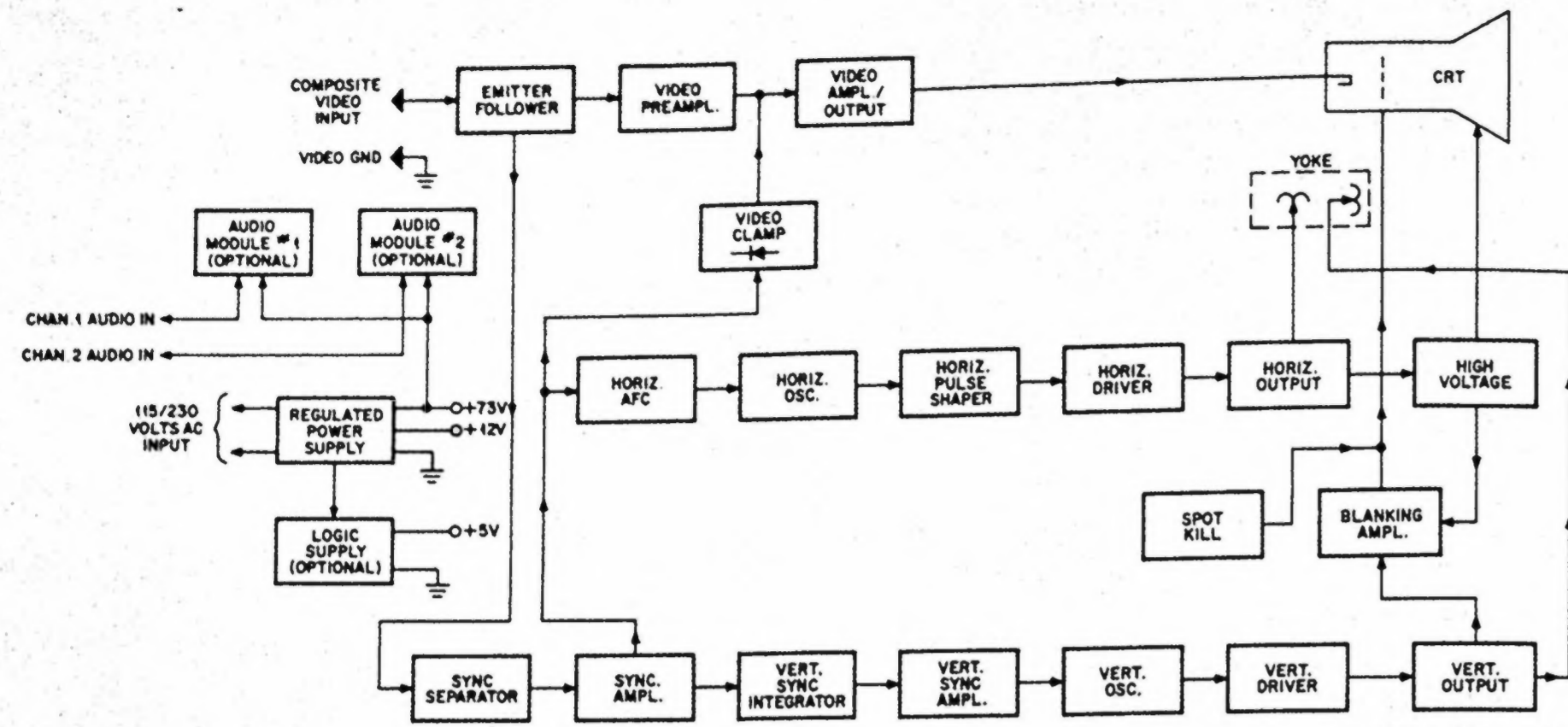

Block Diagram

THEORY OF OPERATION

POWER SUPPLY

The power supplies are transformer operated, full-wave, regulated supplies which maintain constant output voltages for input line variations of 103 volts AC to 130 volts AC, or 206 volts AC to 260 volts AC. Regulation of the output voltages is accomplished by using positive feedback through the integrated circuit reference amplifier.

+73 VOLT SUPPLY (See Figure 1.)

When the +73 volt supply attempts to increase, the voltage at pin 3 of IC1 will increase while the voltage at pin 2 remains constant due to D20. The increasing voltage at pin 3 will cause the output voltage of the reference amplifier (Pin 6) to increase the forward bias of Q19. The collector voltage of Q19, forward bias of Q18, and the base current of Q17 will all decrease. The resultant proportional increase of Q17 collector-to-emitter voltage will cancel the attempted output voltage increase.

When the +73 volt supply buss attempts to decrease; the voltage at pin 3 of IC1 will decrease while the voltage at pin 2 remains constant. The decreasing voltage at pin 3 will cause the reference amplifier output voltage at pin 6 to decrease the forward bias of Q19. The collector voltage of Q19, the forward bias of Q18 and the base current of Q17 will increase. The collector-to-emitter voltage of

Q17, which is in series with the output, will decrease proportionally to the attempted decrease in the output buss.

Resistor R84 shunts a portion of the output current around Q17 so less power is dissipated within the device. Resistor R82 is the current limiting resistor for Q18 and R86 controls the leakage current of Q17. Resistors R83 and R85 are the collector load for Q19, and R88 and R87 provide an emitter voltage for Q19 within the range of IC1's output voltage variations. Capacitor C45 filters high frequency variations from the voltage at pin 7 of IC1, and C49 is a Miller effect capacitor which eliminates instability. Capacitor C32A filters horizontal frequency variations from the output buss.

Resistor R91 provides bias current for D20, and the value of R99 presents an impedance from pin 2 of IC1 to AC ground (through D20). Capacitor C46 couples high frequency voltage variations, which occur at the output buss, back to pin 3 preventing oscillations for proper operation of the reference amplifier. Resistors R92, R93, and R94 provide voltage division such that the adjustment of R93 can be set equal to the voltage of pin 2 of IC1. Resistor R95 provides bias current for D21 and also provides the +12 volt output. Diode D23 is necessary to temperature compensate for variations within D21. Capacitor C32B filters AC variations from the output of the full-wave bridge.

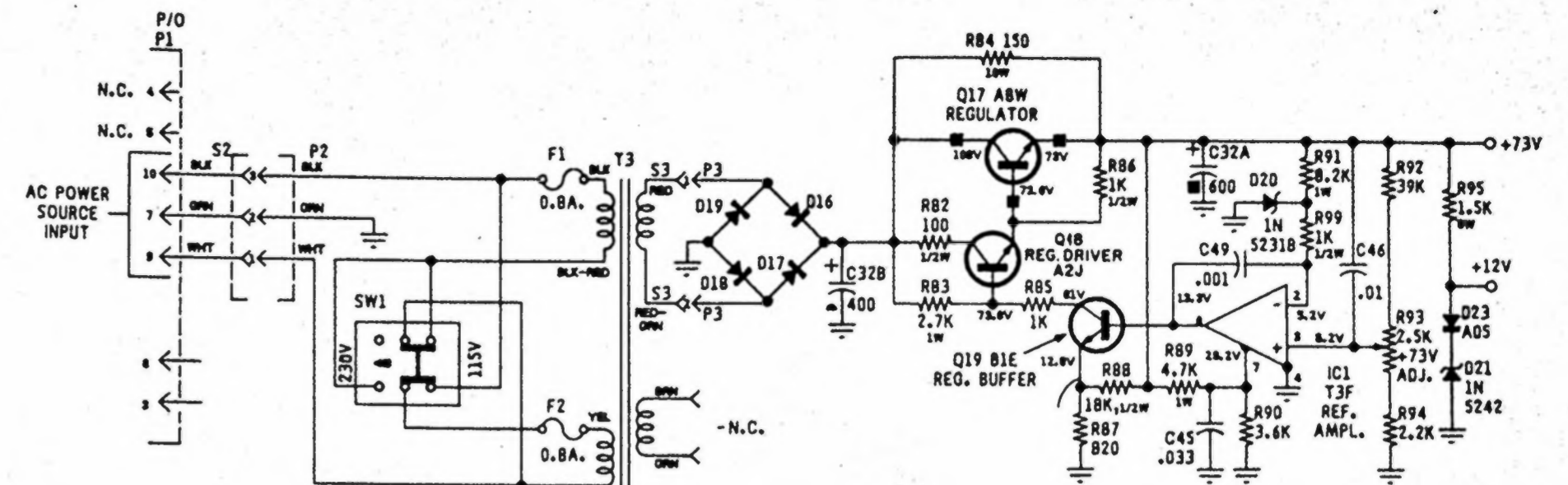

Figure 1.

+5 VOLT SUPPLY (See Figure 2.)

The +5 volt power supply is a simplified form of the +73 volt supply in that it uses a series pass regulator output and a zener diode reference source on one input of the integrated circuit reference amplifier. This supply uses one less stage for voltage regulation. Therefore, the reference voltage is connected to pin 3 instead of pin 2, as in the +73 volt supply.

When the output of the supply attempts to increase, the voltage at pin 2 of IC1 will increase and disturb the balanced condition at the inputs of the reference amplifier. The output voltage at pin 6 of IC1 will decrease causing the forward bias of Q202 to decrease. Transistor Q202 will conduct less and therefore, less base current will be supplied to Q201 via the emitter of Q202. A greater voltage will be present, from collector-to-emitter across Q201, which is directly proportional to the attempted increase in output voltage.

When the output voltage of the supply attempts to de-

crease, the voltage at pin 2 of IC1 will decrease and disturb the balanced condition at the inputs of the reference amplifier. The output voltage at pin 6 of IC1 will increase causing the forward bias of Q202 to increase.

Transistor Q202 will conduct more and therefore, more base current will be supplied to Q201 via the emitter of Q202. A smaller voltage will be present, from collector-to-emitter across Q201, which is directly proportional to the attempted decrease in output voltage.

Capacitor C201 filters line frequency variations from the output supply buss. Resistor R201 provides base bias voltage for Q202 and R204. Resistors R202 and R203 provide the operating voltage for IC1. Resistor R205 establishes the operating current for D202.

The zener diode provides a constant reference voltage for pin 3 of IC1. Capacitor C202 is a Miller effect capacitance which eliminates instability. Resistor R206 sets the 5 volt bias voltage for pin 2 of IC1.

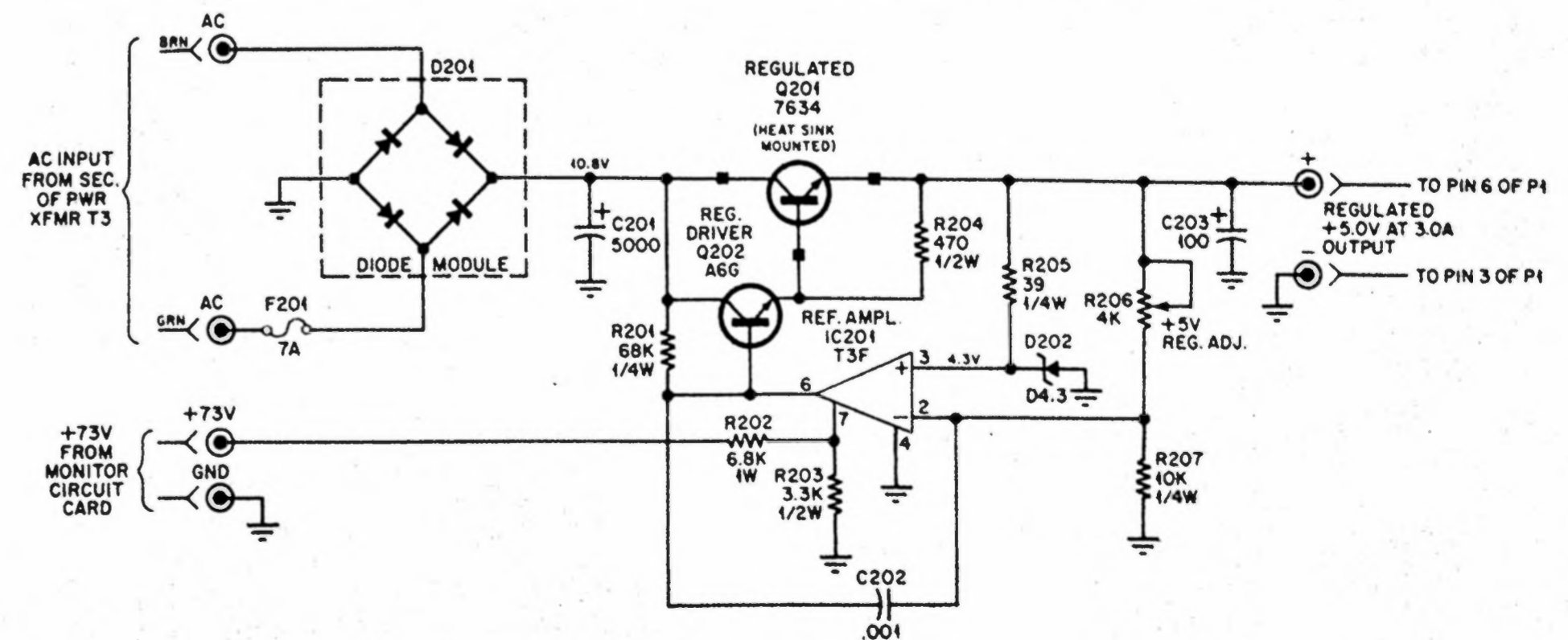

Figure 2.

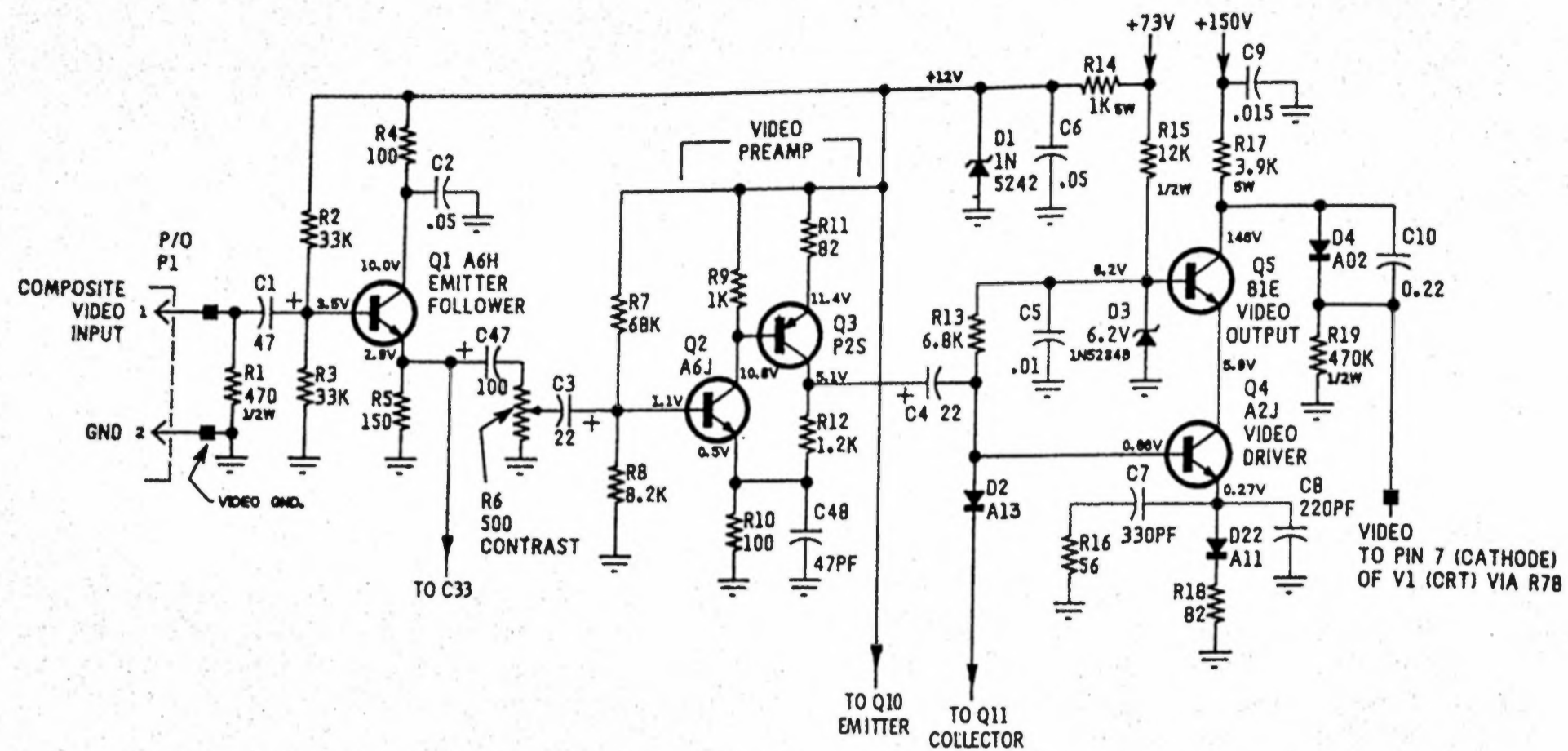

Figure 3.

VIDEO AMPLIFIERS AND OUTPUT (See Figure 3.)

The composite video signal is coupled to the emitter follower Q1 through the input connector P1 and capacitor C1. Transistor Q1 is a buffer stage which matches the impedance of the signal source to the video preamplifier and the sync separator stages. Resistor R1 is a terminating resistor for the video signal source, and resistors R2, R3, R4, and R5 form the biasing network for the stage. Capacitor C2 bypasses higher video frequencies to ground. The composite video signal is coupled from the emitter of Q1 to the sync separator Q10 through C33 and, to the contrast control R6 through C47.

The contrast control varies the amplitude and couples the composite video signal to the base of Q2 through capacitor C3. Transistors Q2 and Q3 are complimentary, direct coupled common emitter amplifiers. The voltage gain (approximately 12) of the preamplifier stage is controlled by the feedback arrangement of R9, R10, R11, and R12. Resistors R7 and R8 provide the base bias voltage for Q2. Capacitor C48 is used for high frequency peaking.

The output of the video preamplifier stage is coupled to the video output stage through capacitor C4. Diode D2 clamps the video signal to approximately +0.7 volts (DC restoration) when a sync pulse turns on the sync amplifier Q11. The video output stage is connected in a cascade configuration. Transistor Q4 is a common emitter amplifier and Q5 is connected in a common base arrangement. Capacitors C7 and C8, and resistor R16, are used for high frequency compensation. Diode D22 is used for temperature compensation and resistor R18 controls the gain of the stage to approximately 47. Diode D3 maintains the base of Q5 at +6.2 volts while capacitor C5 filters the video signal variations from the base voltage. Resistor R13 provides a DC bias path for D2 and, R19 and D4 are used to limit the current through the CRT. Capacitor C10 AC couples the video from the collector of Q5 to the cathode of the CRT if D4 turns off due to high beam currents. Resistor R17 is the collector load for Q5 and R15 provides the bias current for the zener diode D3. Capacitors C9 and C6 filter video frequencies from the +150 volt and +12 volt supplies. Resistor R14 and zener diode D1 are used to supply +12 volts for Q1, Q2, and Q3.

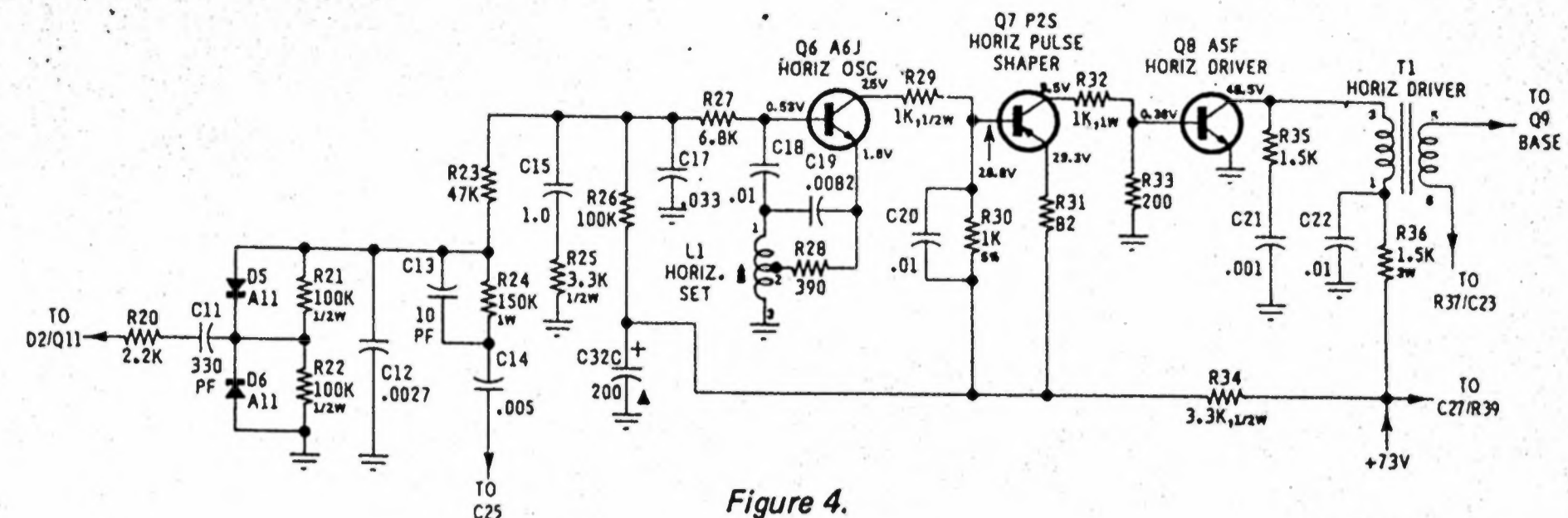

Figure 4.

HORIZONTAL DEFLECTION CIRCUITS (See Figure 4.)

PHASE DETECTOR

The phase detector consists of two diodes (D5 and D6) in a keyed clamp circuit. Two inputs are required to generate the required output, one from the horizontal sync amplifier, Q11, and one from the horizontal output circuit, Q9. The required output must be of the proper polarity and amplitude to correct phase differences between the input horizontal sync pulses and the horizontal time base. The horizontal output (Q9) collector pulse is integrated into a sawtooth by R24 and C12. During horizontal sync time, diodes D5 and D6 conduct, which shorts C12 to ground. This effectively clamps the sawtooth on C12 to ground at sync time. If the horizontal time base is in phase with the sync (waveform A), the sync pulse will occur when the sawtooth is passing through its AC axis and the net charge on C12 will be zero (waveform B). If the horizontal time base is lagging the sync, the sawtooth on C12 will be clamped to ground at a point negative from the AC axis. This will result in a positive DC charge on C12 (waveform C). This is the correct polarity to cause the horizontal oscillator to speed up to correct the phase lag. Likewise, if the horizontal time base is leading the sync, the sawtooth on C12 will be clamped at a point positive from its AC axis. This results in a net negative charge on C12 which is the required polarity to slow the horizontal oscillator (waveform D). Components R23, C15, R25 and C17 comprise the phase detector filter. The bandpass of this filter is chosen to provide correction of horizontal oscillator phase without ringing or hunting. Capacitor

C13 times the phase detector for correct centering of the picture on the raster.

HORIZONTAL OSCILLATOR

The horizontal oscillator employs the principles of the Hartley type oscillator. Its operating frequency is sensitive to its DC base input voltage, thus permitting the frequency of the oscillator to be varied by the output voltage of the phase detector. The main frequency determining components are L1, C19, and R28. The oscillator operates as a switch being biased alternately into saturation and cut-off. The initial forward starting bias is supplied via R26.

HORIZONTAL PULSE SHAPER AND DRIVER

The horizontal pulse shaper Q7, serves as a buffer stage between the horizontal oscillator and driver. Capacitor C20, and resistor R30, combine to shape the input waveform to the required duty cycle of 50%, which is necessary to drive the horizontal output stage.

The horizontal driver Q8, operates as a switch to driving horizontal output transistor Q9 through T1. Because of the low impedance drive and fast switching times, very little power is dissipated in Q8.

Resistor R35, and capacitor C21 provide damping to suppress ringing in the primary of T1 when Q8 goes into cut-off. Resistor R36, is used for current limiting in the collector of Q8, and C22 filters the horizontal frequency variations from the DC side of the transformer primary.

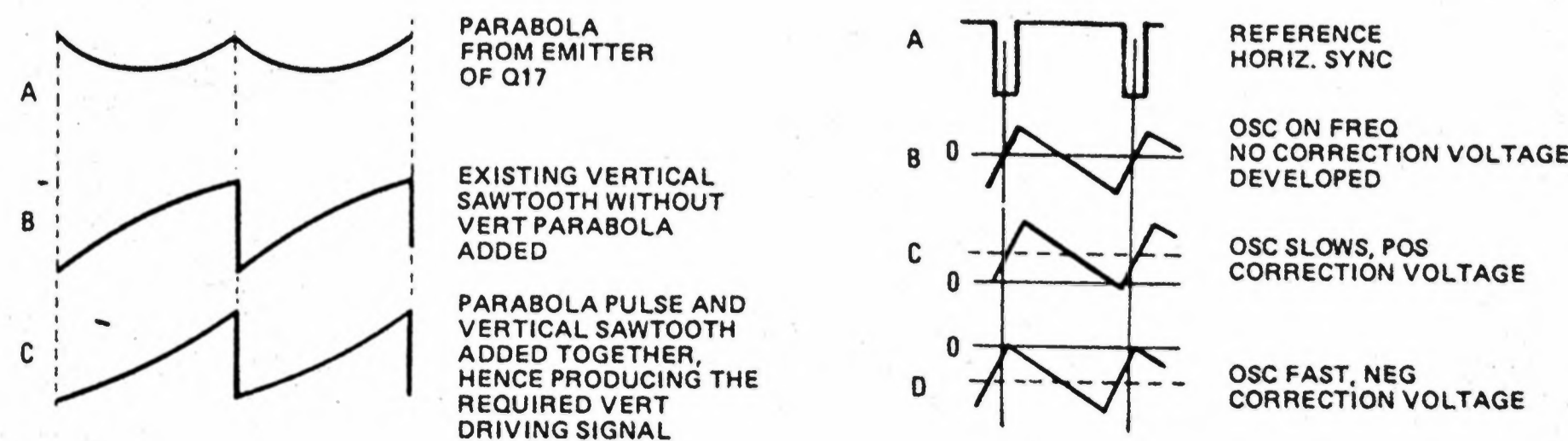

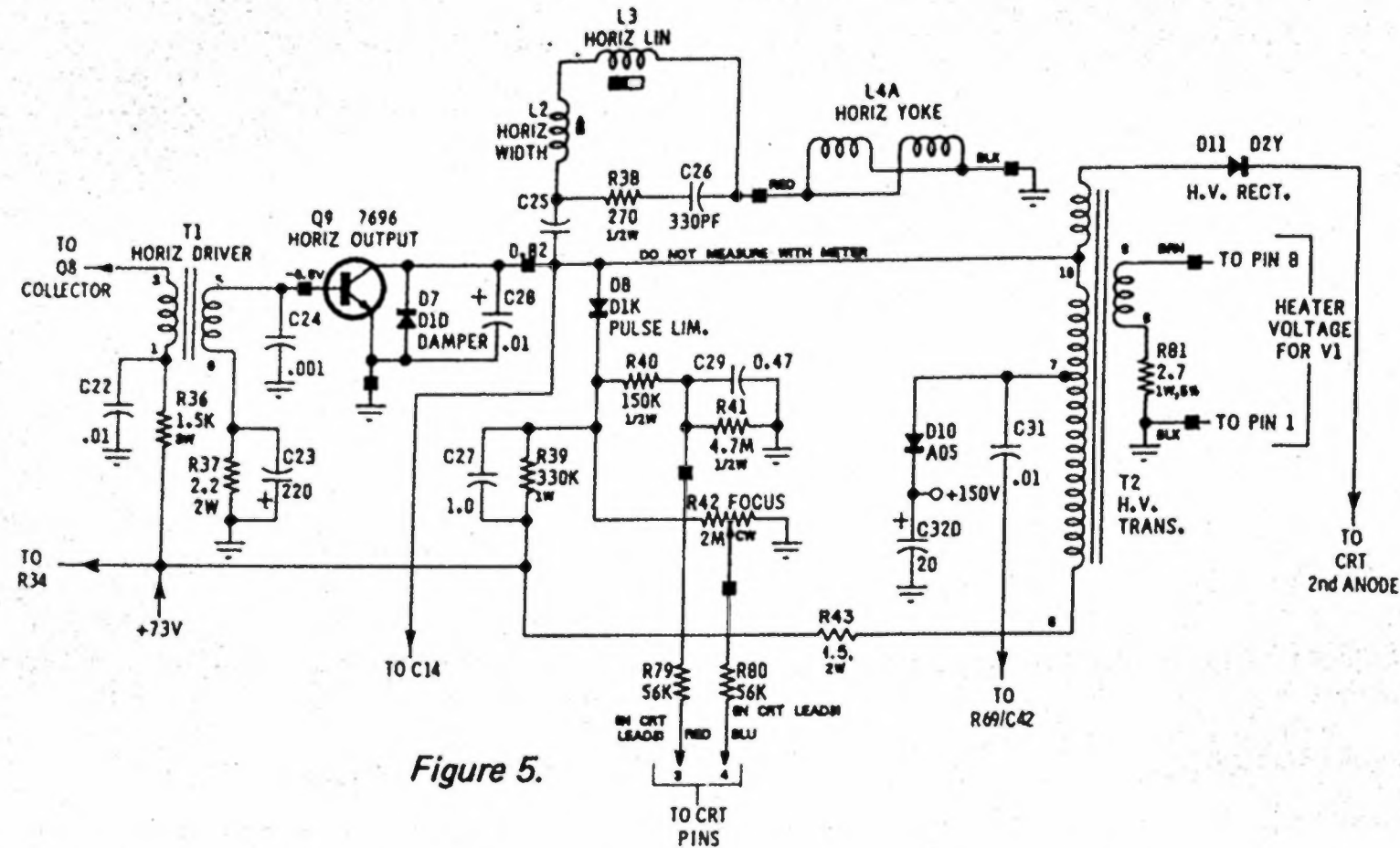

Figure 5.

HORIZONTAL OUTPUT (See Figure 5.)

The secondary of T1 provides the required low drive impedance for Q9. Resistor R37, limits current in the base of Q9, while capacitor C23 provides additional reverse bias to keep Q9 turned off during the horizontal retrace pulse. Transistor Q9 operates as a switch which, once each horizontal time period, connects the supply voltage across the parallel combination of the horizontal deflection yoke and the primary of T2. The required sawtooth deflection current through the horizontal yoke is formed by the L-R time constant of the yoke and output transformer primary. The horizontal retrace pulse charges C27 through D8 to provide operating voltage for G2 of the CRT. Momentary transients at the collector of Q9, should they occur, are limited to the voltage on C27 since D8 will conduct if the collector voltage exceeds this value.

The damper diode D7, conducts during the period between retrace and turn on of Q9 to reduce retrace overshoot and capacitor C28 is the retrace tuning capacitor. Capacitor C25 blocks DC from the deflection yoke. Components R38 and C26 are damping components for the width and linearity coils. Capacitor C32D is charged through D10 developing the video output supply voltage.

SYNC CIRCUITS (See Figure 6.)

The video signal is coupled from the emitter of Q1 to the base of Q10 through C33. The negative going sync tips turn on Q10 and are clamped to the value of the base voltage due to the base-emitter diode junction. The video information within the composite video signal, however, is less negative and Q10 remains off between each sync tip. Therefore, the waveform at the collector of Q10 will contain only the composite sync pulse information.

Resistors R45 and R46, provide base bias for Q11. The composite sync pulses are amplified and inverted by Q11 where they are coupled to the vertical sync integrator Q12, the horizontal phase detector, and the video clamp diode D2. Resistors R47, R48, and R49, are the collector load for Q11, also providing base bias for Q12. Resistor R50, limits current through the base-emitter junction of Q12, and R51 is its collector load. Components R52, C34, R53, C35, and R54 form a double integrator which removes the horizontal pulses from the composite sync signal, leaving the vertical pulses to be amplified by Q13 and coupled to the vertical oscillator.

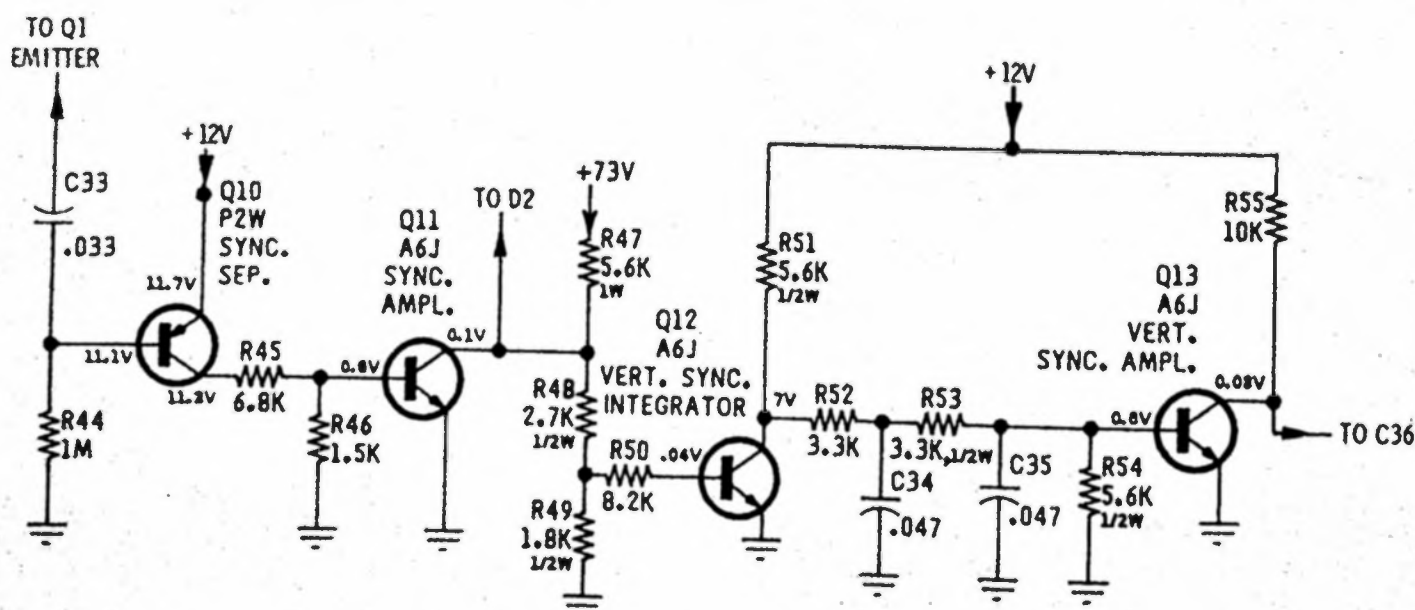

Figure 6.

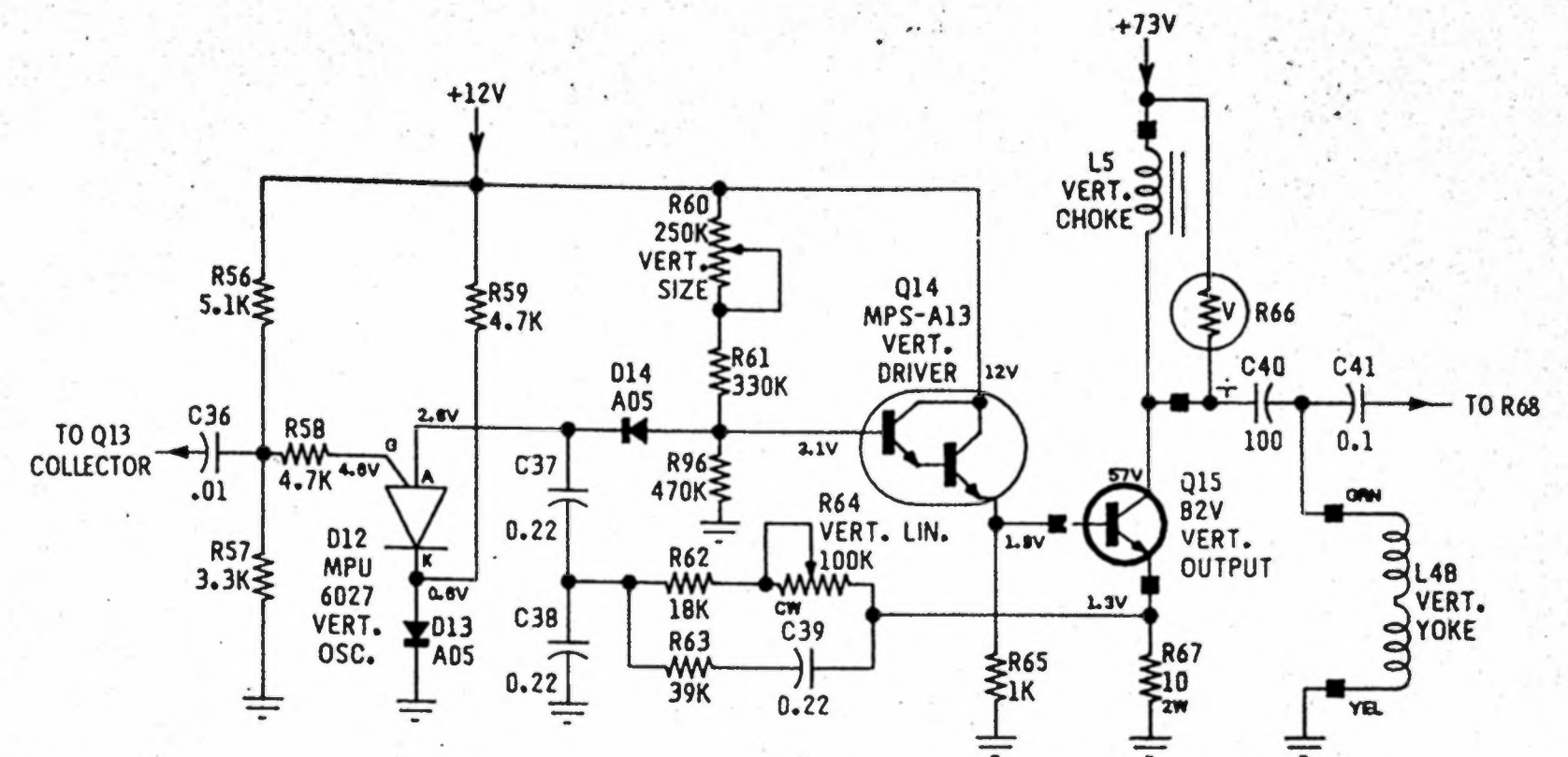

Figure 7.

VERTICAL OSCILLATOR AND OUTPUT (See Figure 7.)

The vertical oscillator is a relaxation oscillator and operates at a free running frequency that is set by the value of resistors R56 and R57. The series combination of C37 and C38 charges through D14, R61, and R60, until D12 turns on. This occurs when the anode voltage of D12 exceeds the gate voltage by approximately 1.0 volt. When D12 conducts, C37 and C38 are discharged to nearly zero volts then D12 turns off and the cycle repeats. The value of R61 and the setting of R60 determines the amplitude of the waveform.

Diode D14 provides a small incremental voltage above ground to overcome the forward base-emitter drop of Q14 and, D13 provides temperature compensation for the output stage. Resistor R96 provides a constant oscillator load for variations in input impedance of Q14. Transistor Q14 is an emitter-follower used to transform the high impedance drive sawtooth to a low impedance drive for Q15.

The vertical choke L5, acts as a current source during linear scan time and provides a high voltage pulse to aid retrace when Q15 shuts off. To limit this pulse to a safe value, a varistor, R66, is connected across the choke.

Since the impedance of the choke decreases when the collector current of Q15 increases, severe vertical non-linearity will result unless some compensation is employed.

Resistors R64 and R62 couple the emitter voltage of Q15 to the junction of C37 and C38. This path is resistive and the waveform coupled back will be integrated by C38. This results in a pre-distortion of the drive sawtooth. This is done to compensate for the non-linear charging of C37, C38 and the changing impedance of C5. An additional feedback path through R63 and C39 serves to optimize

the drive waveshape for best linearity. Capacitor C40, couples the signal to the vertical yoke winding and blocks DC.

SPOT KILL (See Figure 8.)

The spot kill circuitry is utilized to reduce the effect of the electron beam concentrating on one area of the CRT after the monitor is turned off. This is accomplished by raising the arm of potentiometer R73 to the +150 volt level and, therefore, increasing the brightness to maximum to dissipate the high voltage charge which normally remains in the CRT.

When the monitor is operating, transistor Q20 is on and its collector is near zero volts. Capacitor C44 charges through the base-emitter junction of Q20 and R97. Resistor R72 provides the base bias voltage required to keep Q20 on. When the monitor is turned off, the falling +73 volts is coupled to the base of Q20 to turn off the transistor causing its collector voltage to rise to approximately +150 volts. Diode D24 prevents the negative voltage swing at the base of Q20 from exceeding the reverse voltage rating of the transistor.

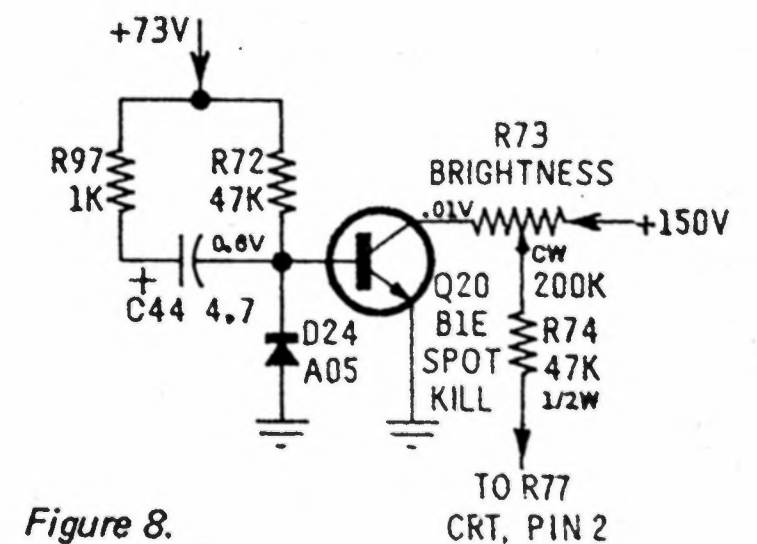

Figure 8.

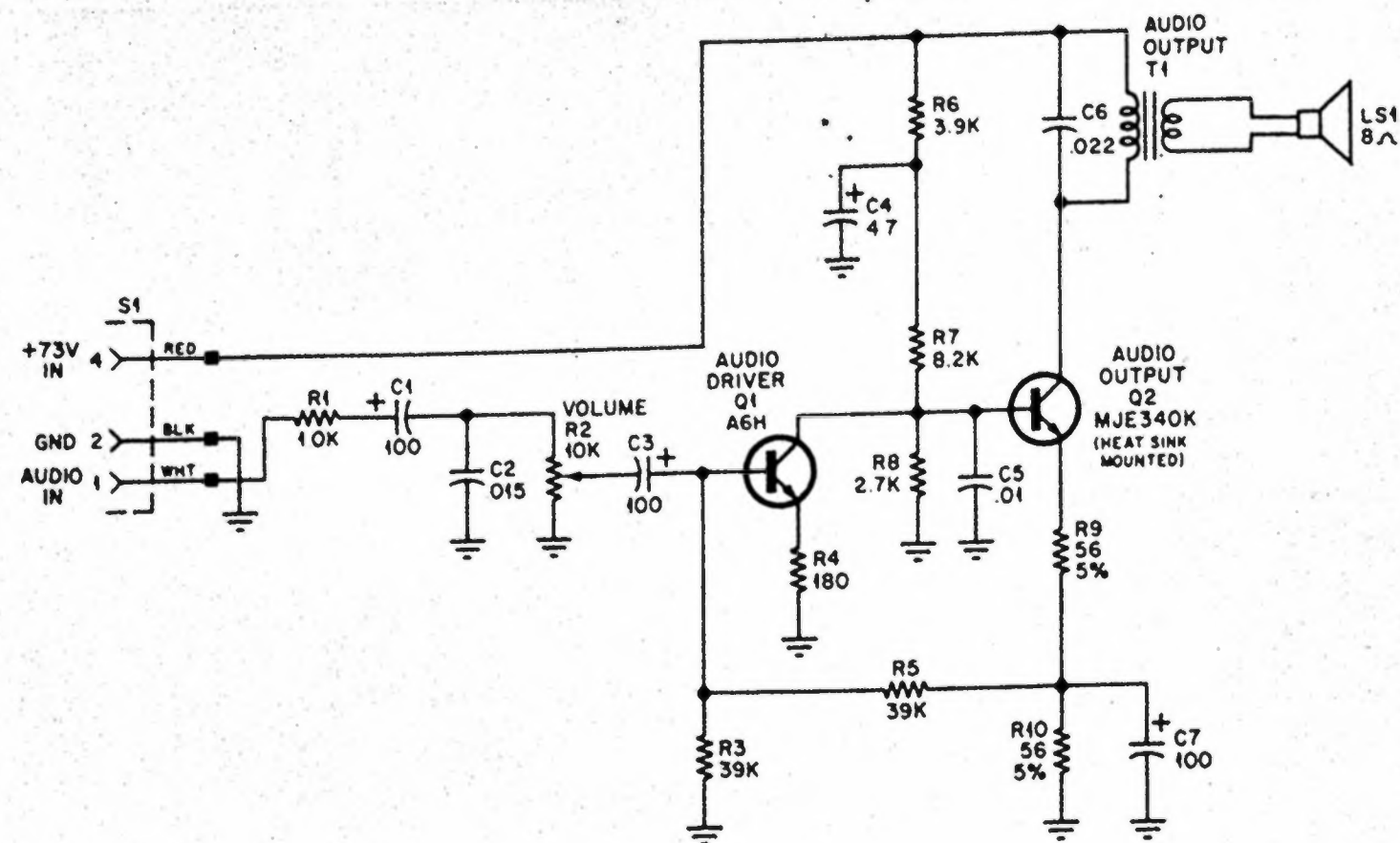

Figure 9.

AUDIO MODULE (See Figure 9.)

The audio module has been designed as an optional add-on unit to the M5010-155 and M7010-155 monitors. The module uses the +73 volt monitor power supply which is accessible through connectors P4 and P5. The audio input signal is applied to the 12-pin input connector, P1, located at the rear of the chassis. The audio amplifiers, Q1 and Q2, are connected in a negative feedback arrangement to improve bias stabilization.

Resistor R1 and capacitor C2 form a low pass filter which filters out high frequency logic pulses that may saturate Q1. Capacitors C1 and C3 block DC from R2, eliminating the possibility of noise generation within R2 as its setting is varied. Capacitor C3 also prevents the bias of Q1 from being shifted as R2 is adjusted. Resistors R3, R5, R9 and R10 form a negative feedback network which sustains bias stabilization for Q1 and Q2. Resistor R9 presents degeneration at the emitter of Q2 for low signal distortion and C7 is a bypass capacitor which eliminates audio degeneration within the feedback network. Resistor R6 and capacitor C4 decouple the ripple from the +73 volt supply. Resistors R7 and R8 are a split collector load for Q1, which provides base drive for Q2. Transformer T1 matches the impedance of the speaker to the output impedance of Q2 while capacitors C5 and C6 are used for high frequency roll-off.

BLANKING AMPLIFIER (See Figure 10.)

The blanking amplifier combines both the vertical and horizontal retrace pulses to turn off the electron beam in the CRT once every horizontal line and once every vertical field.

Capacitor C41 couples the vertical retrace pulses and capacitor C31 couples the horizontal retrace pulses to the blanking amplifier. Resistor R68 determines the amplitude of the vertical pulses while R69 determines the amplitude of the horizontal pulses. Capacitor C42 bypasses R69 to couple the leading and trailing edges of the horizontal retrace pulses to the amplifier. Resistor R70 allows C41 to discharge when the retrace pulses swing below zero volts. Diode D15 prevents the retrace overshoot from exceeding the reverse voltage rating of Q20. Resistor R71 permits Q20 to turn off between retrace pulses, while R75 and R76 provide the collector voltage for Q20. Capacitor C43 couples the blanking pulses to the control grid of the CRT.

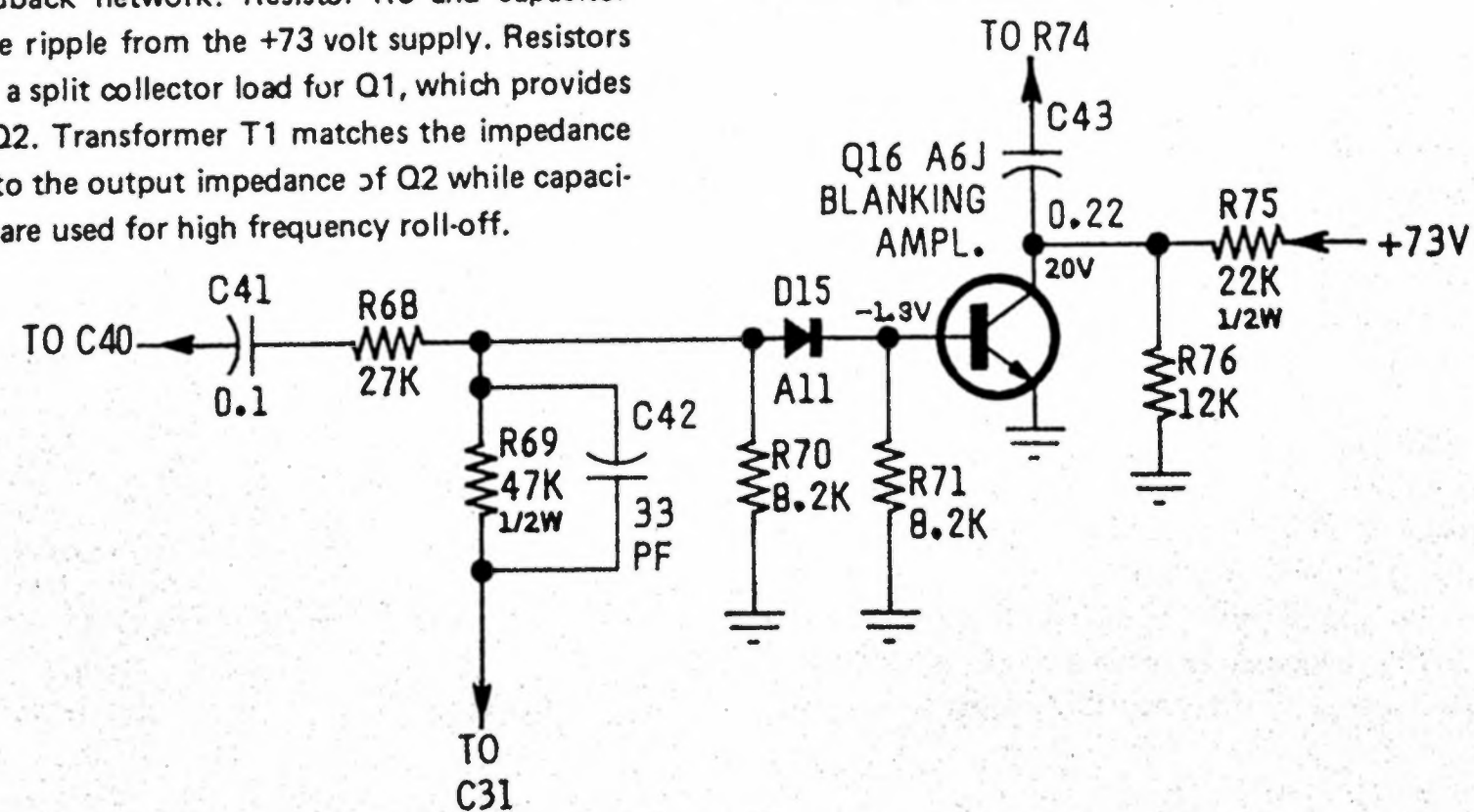
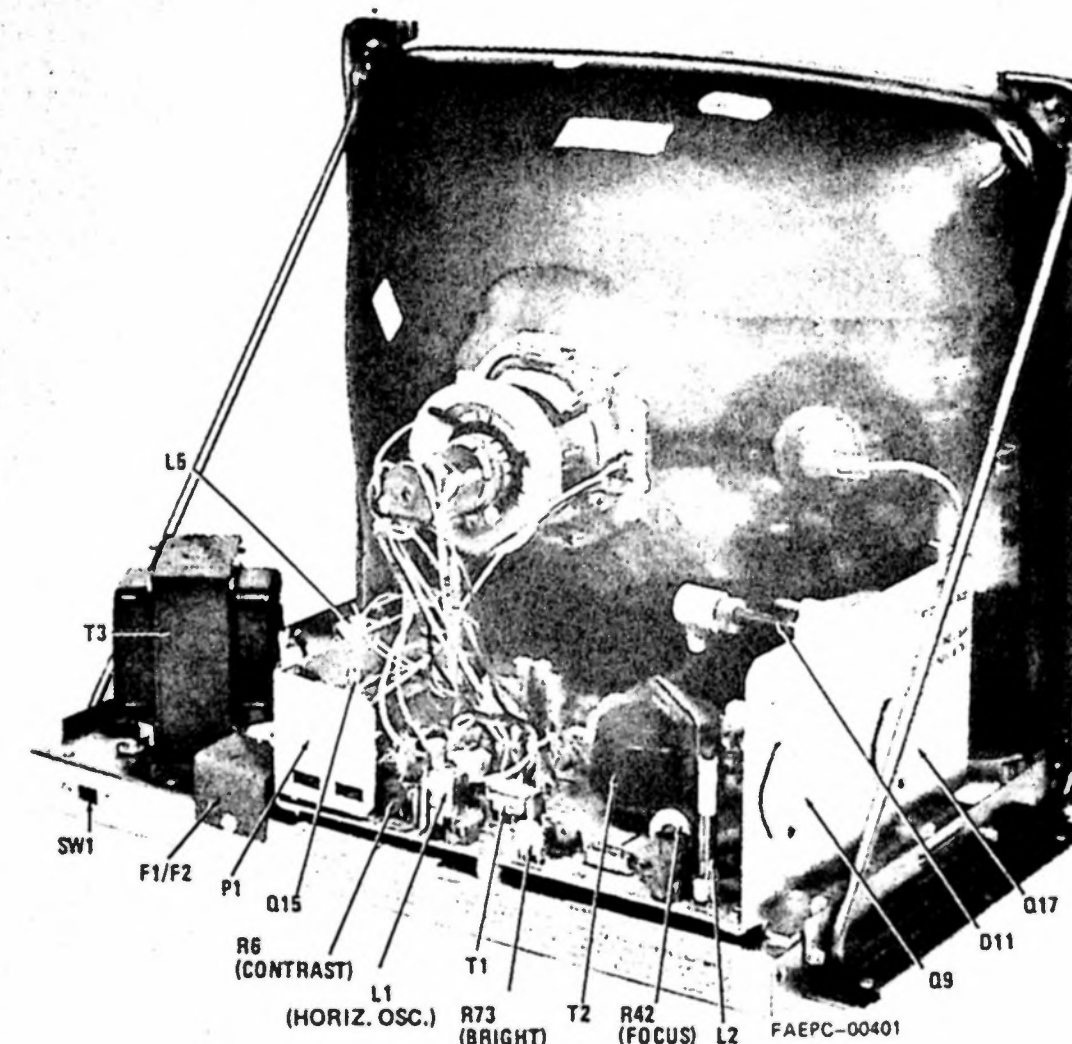
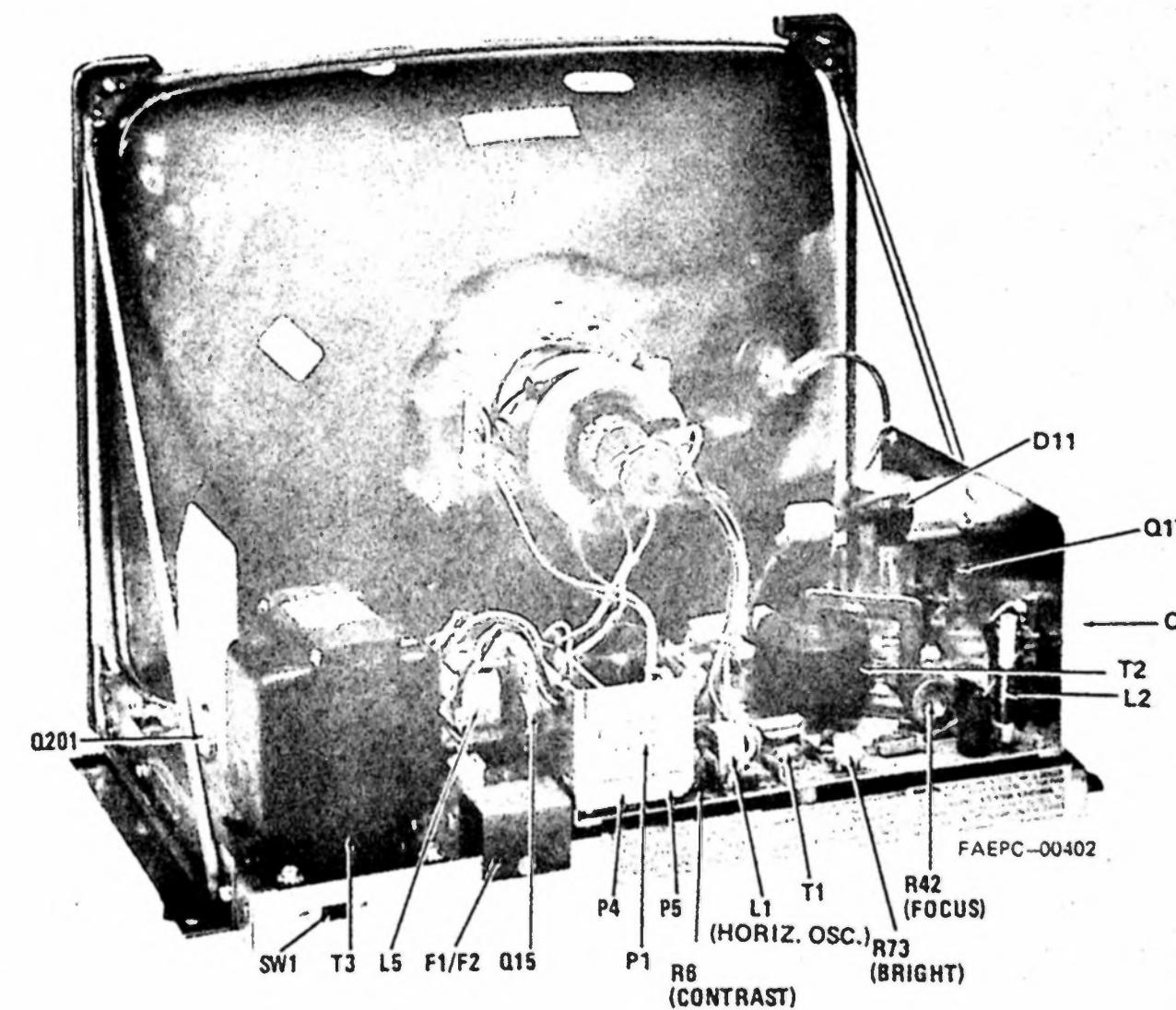

Figure 10.



M5000-155, M7000-155, Chassis Rear View - Component Location



M5010-155, M7010-155, Chassis Rear View - Component Location

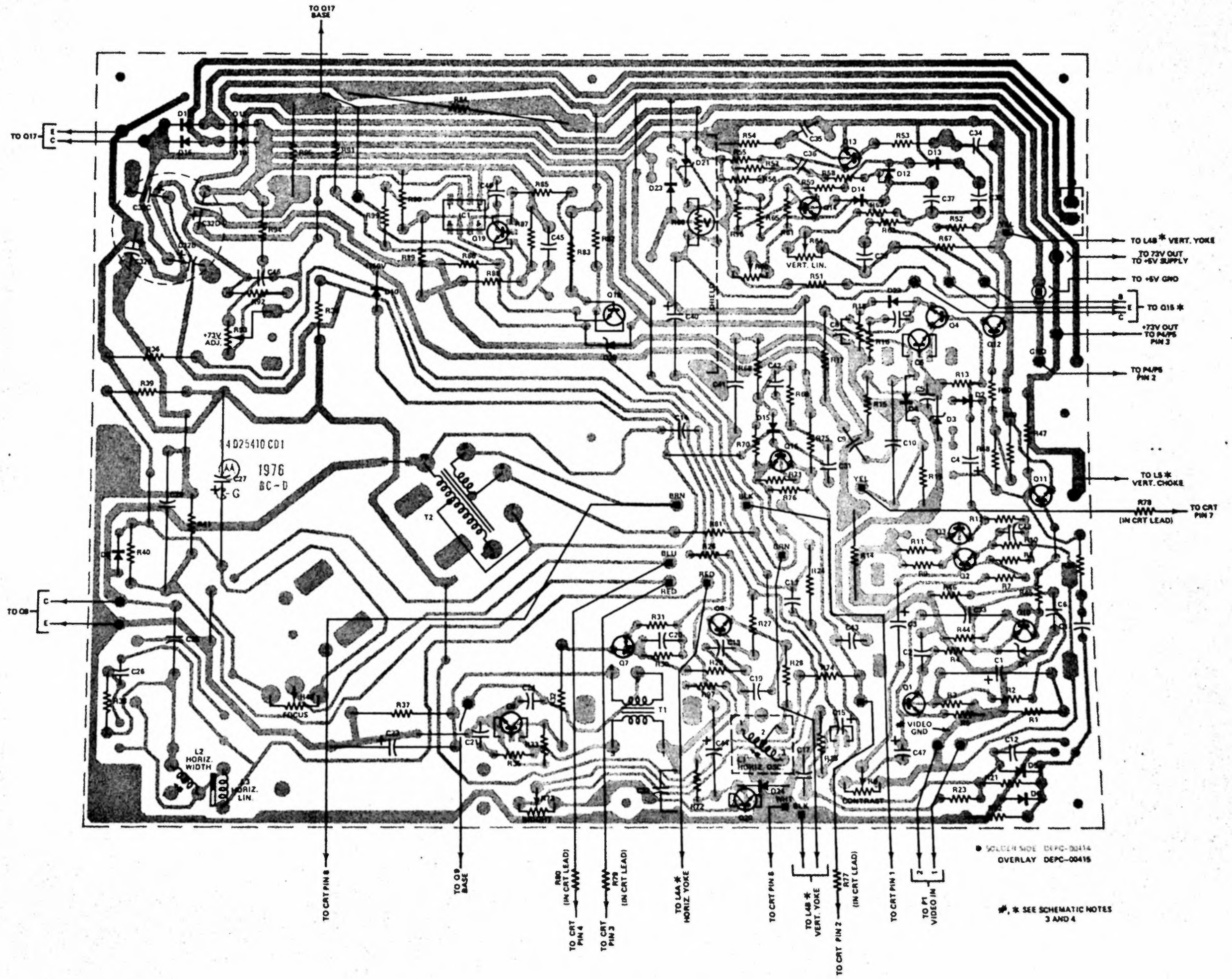

Monitor Circuit Board Detail — Solder View

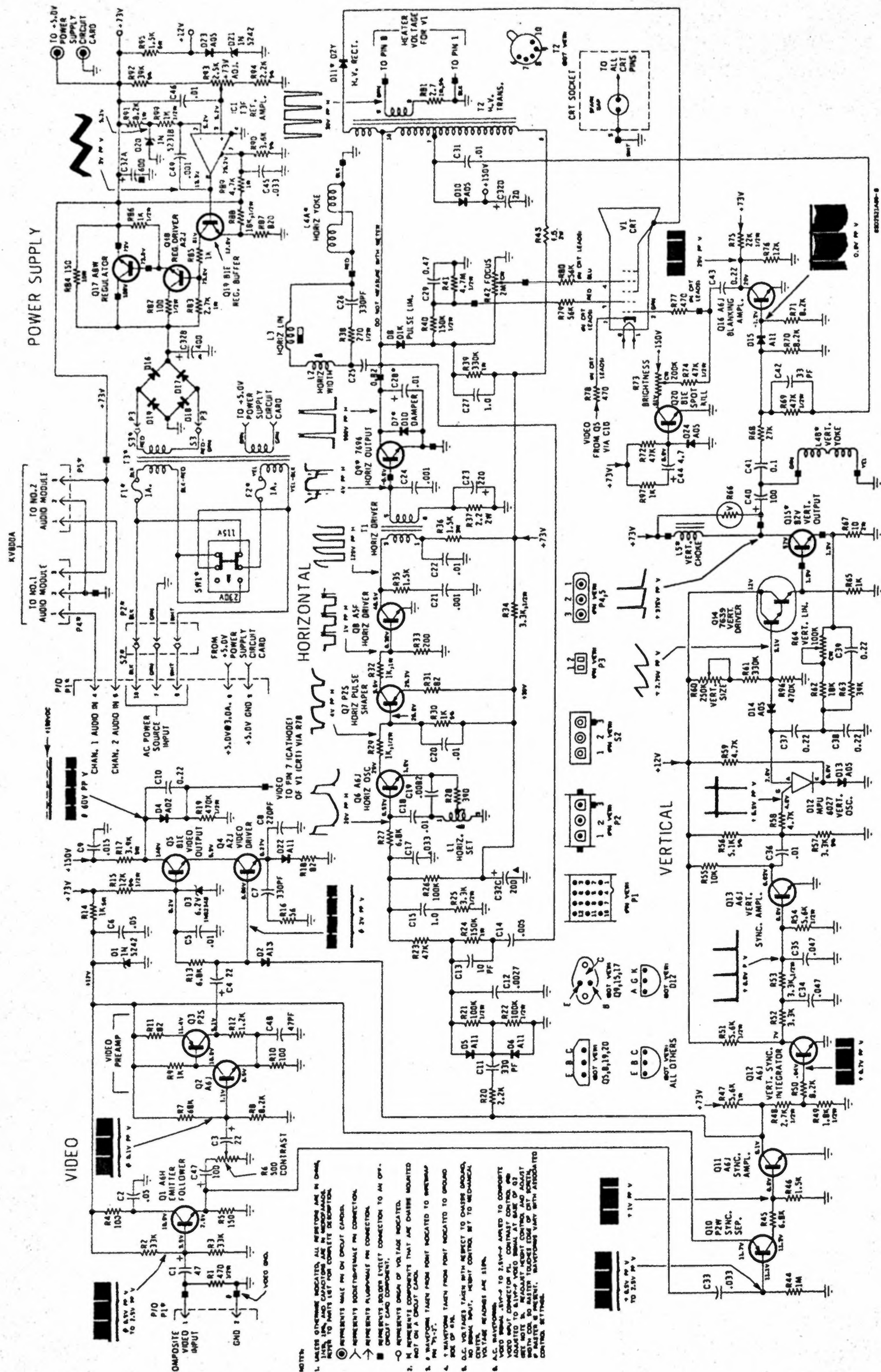

M5010-155, M7010-155 - Diagram Schematic

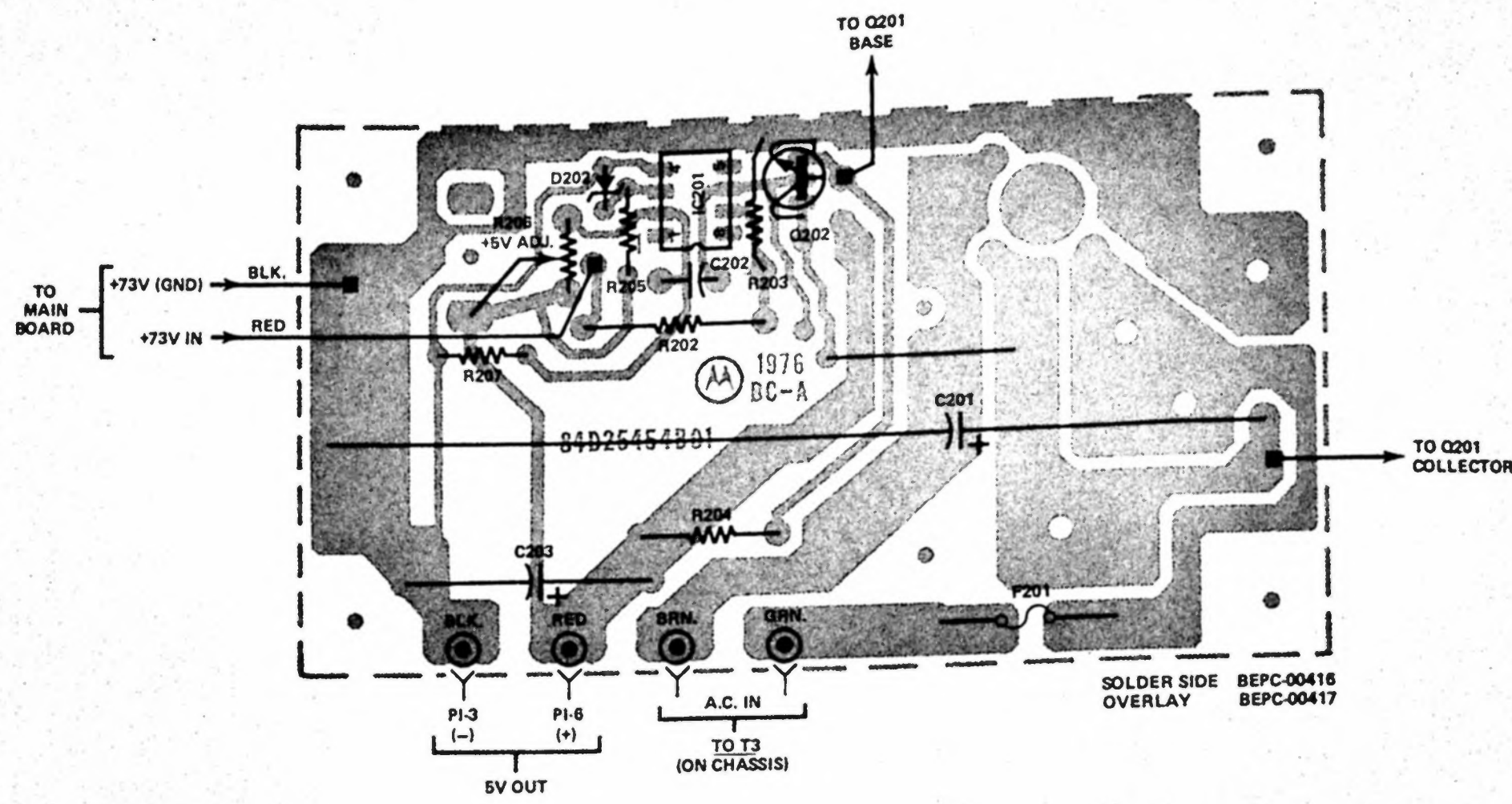

+5 Volt Supply Circuit Card Detail - Solder View

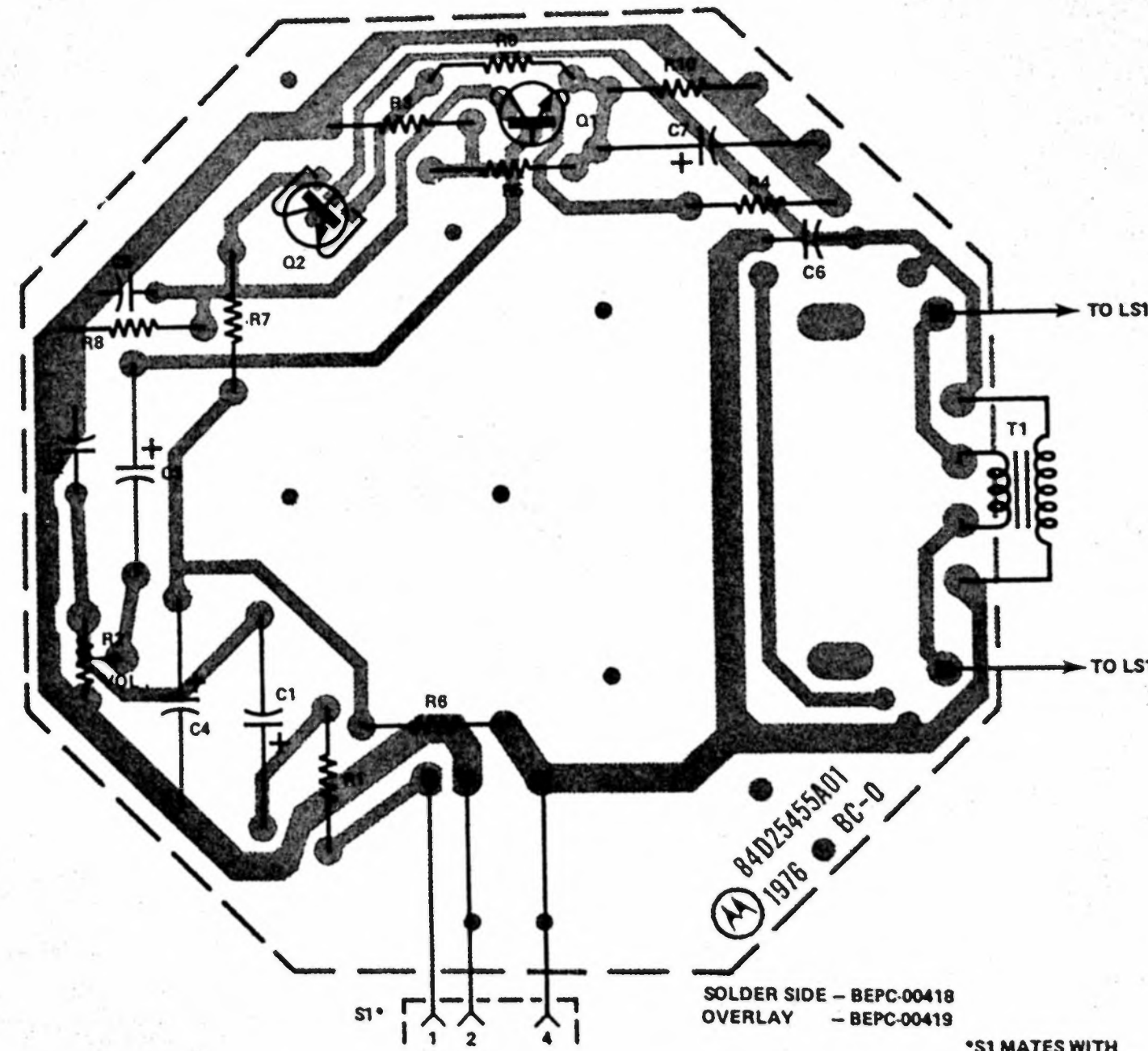

Audio Module Circuit Card Detail - Solder View

*S1 MATES WITH P4/P5 ON MONITOR CHASSIS.

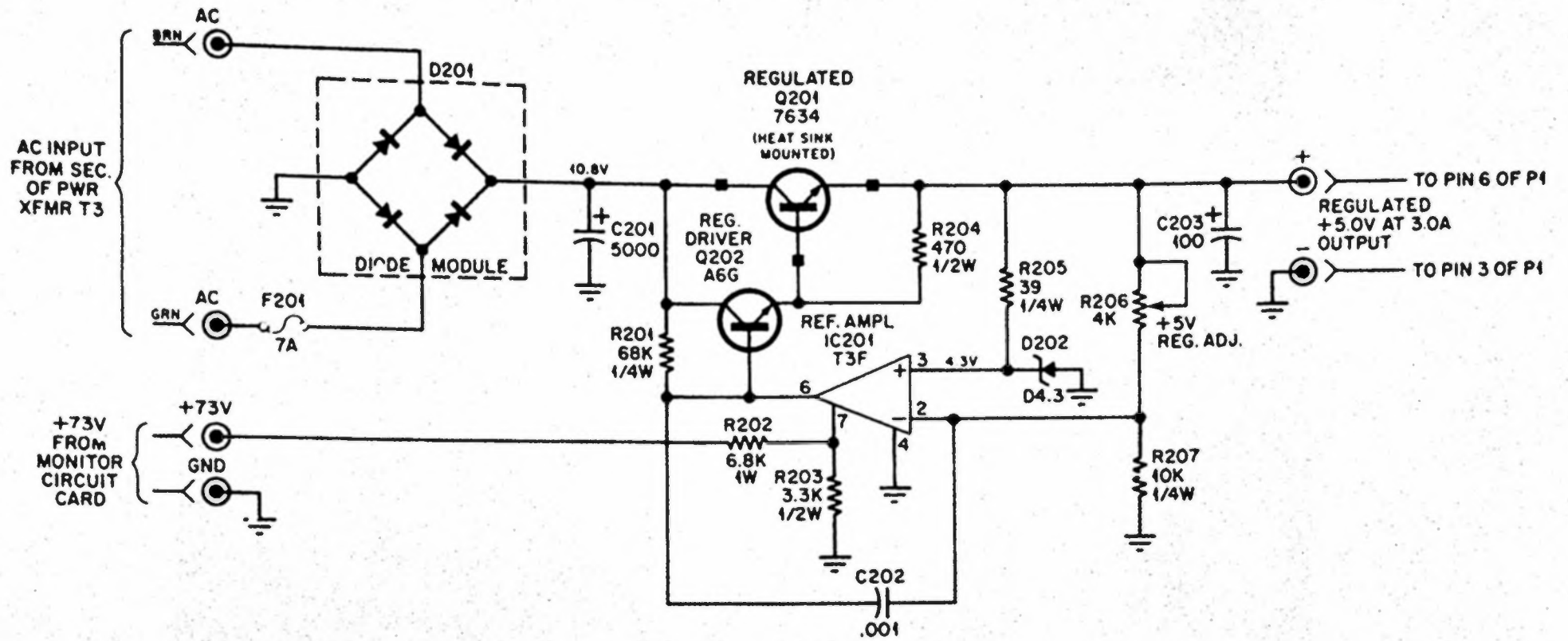

+5 Volt Supply – Diagram Schematic

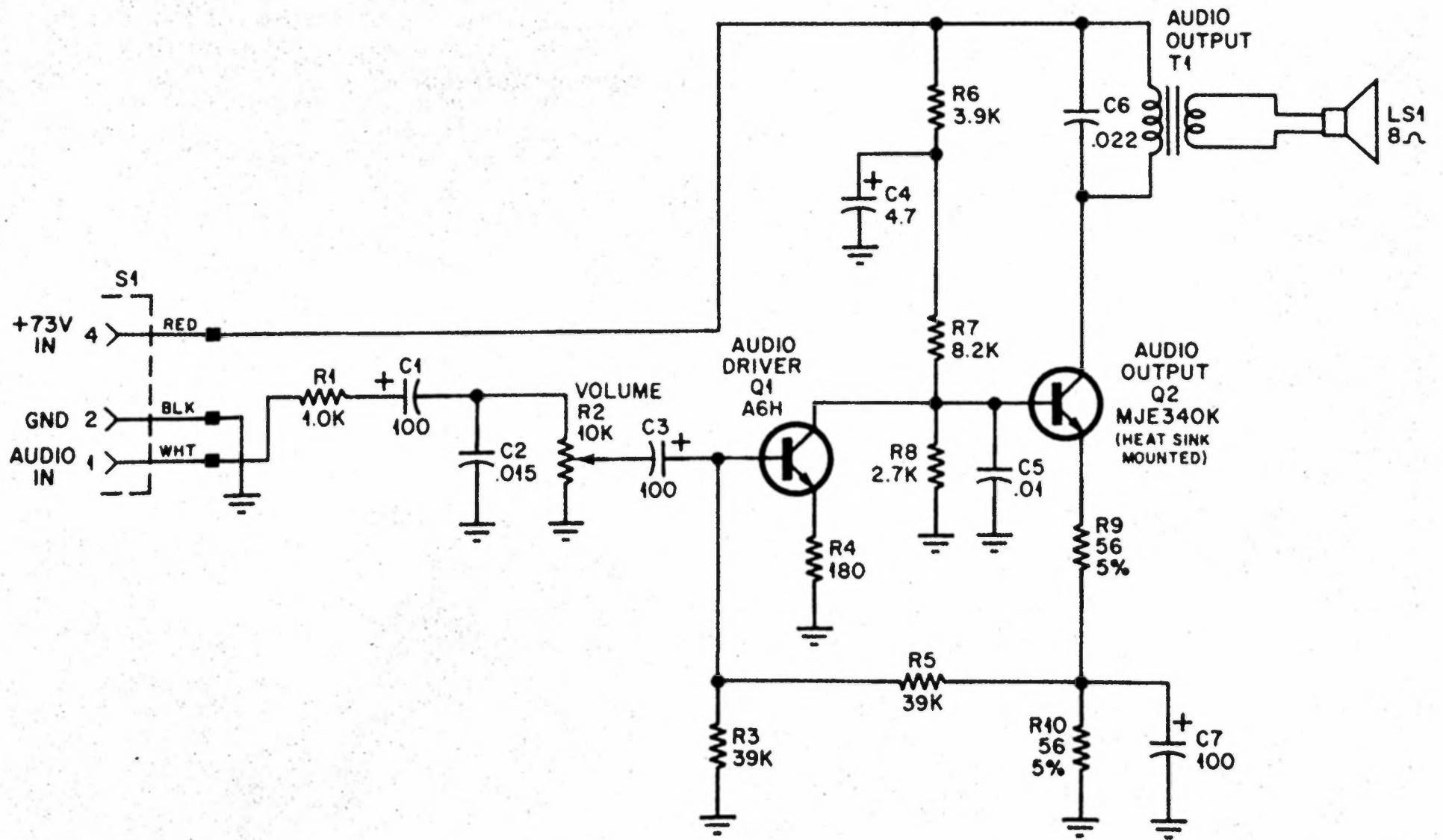

Audio Module – Diagram Schematic

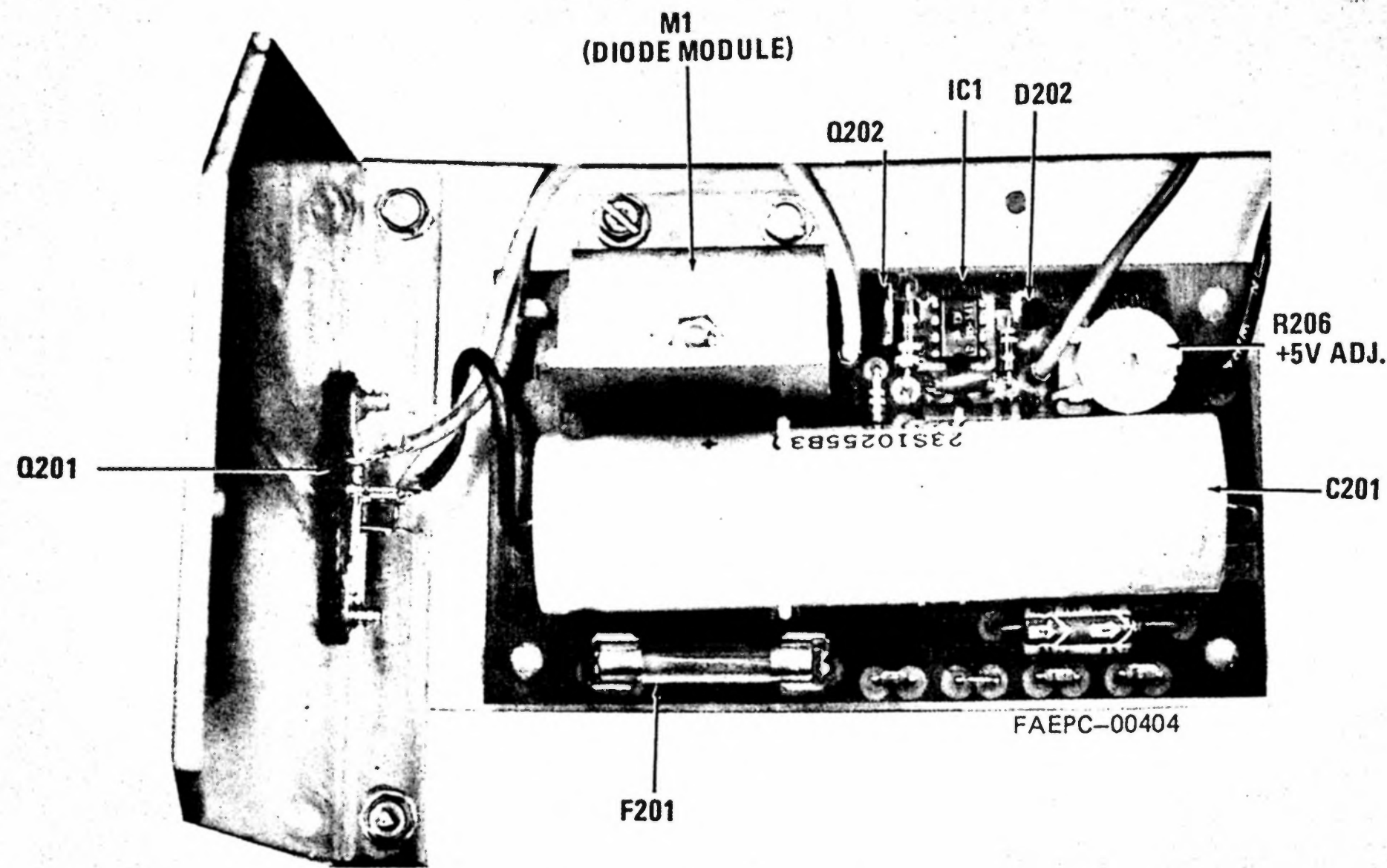

+5 Volt Circuit Card Detail — Component Location

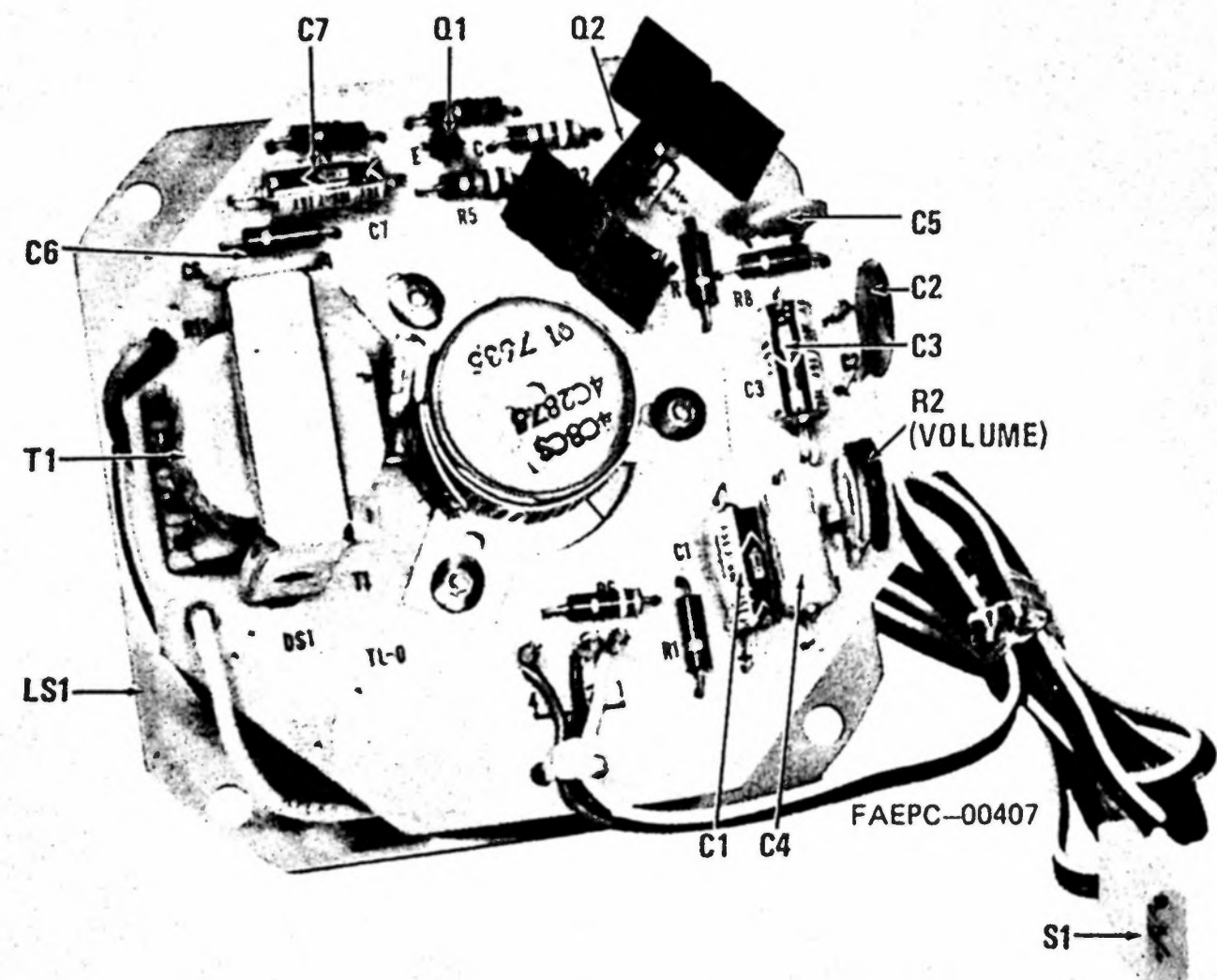

Audio Module — Circuit Card Detail - Component Location

MONITOR PARTS LIST

REF. NO.	PART NUMBER	DESCRIPTION	REF. NO.	PART NUMBER	DESCRIPTION
CAPACITORS: (ALL VALUES ARE IN MICROFARADS UNLESS OTHERWISE NOTED.)			FUSES:		
C1	23S10255A27	47, 50V; Lytic	F1, F2	65S138269	Fuse, 0.8A—250V
C2	21S135660	.05, +80—20, Z5V, 50V; Cer. Disc	INTEGRATED CIRCUITS:		
C3, C4	23S187A26	22, 25V; Lytic	IC1	51S10732A01	Ref. Ampl.; T3F
C5	21S180E60	.01, +80—20; Z5V, 50V; Cer. Disc	COILS/CHOKES:		
C6	21S135660	.05, +80—20, Z5V, 50V; Cer. Disc	L1	24C25448A01	Coil, Horiz. Osc.
C7	21S131625	330pf, 10%, X5F, 500V; Cer. Disc	L2	24D25603A09	Coil, Horiz. Width
C8	21S180B87	220 pf, 10%, X5F, 500V; Cer. Disc	L3	24D25248A14	Coil, Horiz. Lin.
C9	8S10191B99	.015, 10%, 250V; Poly.	L4	24D25261A09	Coil, Defl. (M5000—155, M5010-155)
C10	8S10212B18	0.22, 10%, 400V; Mtlz. Poly.	L4	24D25261A10	Coil, Defl. (M7000—155, M7010-155)
C11	21S131625	330pf, 10%, X5F, 500V; Cer. Disc.	L5	25D25221C12	Choke, Vertical
C12	21S180C41	.0027, 10%, Z5F, 500V; Cer. Disc	TRANSISTORS:		
C13	21S180C02	10pf, 10%, N150, 500V; Cer. Disc	Q1	48S137171	Emitter Follower; A6H
C14	21S180D34	.005, 20%, Z5F, 1KV; Cer. Disc	Q2	48S137172	Video Pre—Ampl.; A6J
C15	23S10229A32	1.0, 16V; Lytic	Q3	48S137127	Video Pre—Ampl.; P2S
C17	8S10191B90	.033, 10%, 250V; Poly.	Q4	48S134952	Video Driver; A2J
C18	8S10299B28	.01, 10%, 100V; Polycarb.	Q5	48S137476	Video Output; B1E
C19	8S10299B29	.0082, 10%, 100V; Polycarb.	Q6	48S137172	Horiz. Osc.; A6J
C20	8S10191B98	.01, 10%, 250V; Poly.	Q7	48S137127	Horiz. Pulse Shaper; P2S
C21	21S180B51	.001, 10%, X5F, 500V; Cer. Disc	Q8	48S137093	Horiz. Driver; A5F
C22	8S10191B98	.01, 10%, 250V; Poly.	Q9	48S137570	Horiz. Output; B2L
C23	23S10255B50	150, 10V; Lytic	Q10	48S137173	Sync Separator; P2W
C24	21S180B51	.001, 10%, X5F, 500V; Cer. Disc	Q11	48S137172	Sync Ampl.; A6J
C25	8S10299B27	0.82, 10%, 200V; Mtlz. Polycarb.	Q12	48S137172	Vert. Sync Integrator; A6J
C26	21S131625	330pf, 10%, X5F, 500V; Cer. Disc.	Q13	48S137172	Vert. Sync Ampl.; A6J
C27	8S10212A11	1.0, 10%, 630V; Mtlz. Poly.	Q14	48S137639	Vert. Driver; MPS A13
C28	8S10571A06	.01, 5%, 1200V; Polyprop. Foil	Q15	48S137596	Vert. Output; B2V
C29	8S10212B53	0.47, 10%, 630V; Mtlz. Poly.	Q16	48S137172	Blanking Ampl.; A6J
C31	8S10191B98	.01, 10%, 250V; Poly.	Q17	48S137368	Regulator; A8W
C32	23S10255B73	20/200, 400/125, 600/100, 200/50; Lytic	Q18	48S134952	Reg. Driver; A2J
C33	8S10191A51	.033, 10%, 160V; Poly.	Q19	48S137476	Reg. Buffer; B1E
C34, C35	8S10191A32	.047, 10%, 250V; Poly.	Q20	48S137476	Spot Kill; B1E
C36	21S180E60	.01, +80—20, Z5V, 50V; Cer. Disc	RESISTORS/CONTROLS:		
C37, 38, 39	8S10191B67	0.22, 10%, 250V; Poly.	NOTE: ONLY POWER OR SPECIAL RESISTORS ARE LISTED. USE THE DESCRIPTION WHEN ORDERING STANDARD VALUES OF FIXED RESISTORS UP TO 2 WATTS.		
C40	23S10255A60	100, 63V; Lytic	R6	18D25245A27	Control, Contrast; 500
C41	8S10212B16	0.1, 20%, 400V; Mtlz. Poly.	R14	17S135204	100, 10%, 5W
C42	21S180C82	0.33, 10%, N150, 500V; Cer. Disc.	R17	17S10731A01	3.9K, 5%, 5W
C43	8S10191B67	0.22, 10%, 250V; Poly.	R36	17S10130B07	1.5K, 10%, 3W
C44	23S10255B28	4.7, 100V; Lytic	R42	18D25218A14	Control, Focus; 2M
C45	8S10191B90	.033, 10%, 250V; Poly.	R60	18D25245A29	Vert. Size; 250K
C46	21S132492	.01, +80—20, Z5V, 100V; Cer. Disc	R64	18D25245A31	Vert. Lin.; 100K
C47	23S10255B63	100, 10V; Lytic	R66	6S10201A04	Varistor, 1 ma, 120V, 0.5W
C48	21S180D56	47pf, 10%, N750, 100V; Cer. Disc.	R73	18D25245A28	Control, Brightness; 200K
C49	21S180B51	.001, 10%, X5F, 500V; Cer. Disc	R84	17S135589	150, 10%, 10W
DIODES:			R93	18D25245A21	Control, +73V out Adj.; 2.5K
D1	48S10813A03	Diode, Silicon, Zener; IN5242	R95	10731A03	1.5K, 10%, 5W
D2	48D67120A13	Diode; A13	SWITCHES:		
D3	48S10813A01	Diode, Silicon, Zener; IN5234B	SW1	40S10624A07	Switch, Slide; D.P. D.T.
D4	48S191A02	Rectifier, Silicon; 91A02	TRANSFORMERS:		
D5, D6	48D67120A11	Diode; A11	T1	25D25221A05	Horiz. Driver
D7	48S134921	Diode, Damper; D1D	T2	24D25240B23	H.V. Transformer
D8	48S134978	Diode, Pulse Lim; D1K	T3	25D25239B20	Transformer, Power (M5010—155, M7010—155)
D10	48S191A05	Rectifier, Silicon; 91A05	T3	25D25239B30	Transformer, Power (M5000—155, M7000—155)
D11	48S137114	Rectifier, H.V.; D2Y			
D12	48S137638	Vert. Osc.; MPU6027			
D13, D14	48S191A05	Rectifier, Silicon; 91A05			
D15	48D67120A11	Diode; A11			
D16, 17, 18, 19	48S191A05	Rectifier, Silicon; 91A05			
D20	48S10813A02	Diode, Silicon, Zener; IN5231B			
D21	48S10813A03	Diode, Silicon, Zener; IN5242			
D22	48D67120A11	Diode; A11			
D23, D24	48S191A05	Rectifier, Silicon; 91A05			

MONITOR PARTS LIST (Con't.)

REF. NO.	PART NUMBER	DESCRIPTION	REF. NO.	PART NUMBER	DESCRIPTION
MISC. ELECTRICAL PARTS:			S2	15S10183A81	Housing, Connector; Female (3-Contact, Less Contacts), M5000/M7000
V1	96S241A01	19" - CRT; Type 19VARP4 (M5000/M5010)	S2	15S10183A82	Housing, Connector; Male (3-Contact, Less Contacts), M5010/M7010
V1	96S10848A01	23" - CRT; Type M22VATP4 (M7000/M7010)		39S10184A64	Contact, Receptacle; 3-Req'd. for S2
MECHANICAL PARTS:			S3	15S10183A94	Housing, Connector; Female (2-Contact, less Contacts)
	9B25456A01	Block, Fuse (F1,2)		39S10184A72	Contact, Receptacle; 3-Req'd. for S3
	42D25158C01	Clamp, Defl. Coil		14B25459A01	Insulator, Fuse Cover (F1,2)
	26S10251A08	Heat Sink (Q5)		14A562353	Insulator, Mica (Q9,Q15,Q17)
P1	15S10183A69	Housing, Connector; Female (12-Contact, Less Contacts)		14C25230A01	Insulator, Molded (On D11 Body)
	39S10184A67	Contact, Plug; 5-Req'd M5000/M7000, 9-Req'd; M5010/M7010.		14S10157A30	Insulator, Nylon (2-Req'd); Mtg. P.C. Board
P2	15S10183A82	Housing, Connector; Male (3-Contact, Less Contacts), M5000/M7000		14S10550A02	Insulator, Transistor Cover (Q9,Q15,Q17)
P2	15S10183A81	Housing, Connector; Female (3-Contact, Less Contacts), M5010/M7010		3S136050	Screw, Tpg; 6-20x 1/2 CLU Pan (Mtg. Q9, Q15, Q17 and D11 Socket)
	39S10184A67	Contact, Plug; 3-Req'd for P2		9D25470A01	Socket, CRT; Incl's.R77,R78, R79, R80
P3	28S10586A35	Header, Connector; 2-Contact		9D25201A01	Socket, H.V.and CRT Anode
P4, P5	15S10183B12	Housing, Connector; Female (3-Contact, Less Contacts) M5010/M7010		9C63825A03	Socket, Power Transistor (Q9,Q15,Q17)
	39S10184A84	Contact, Plug; 3 ea. Req'd for P5, M5010/M7010		41D65987A01	Spring Special; CRT Aquadag Gnd.

REPLACEMENT PARTS LIST FOR +5 VOLT SUPPLY (M5010/M7010)

REF. NO.	PART NUMBER	DESCRIPTION
CAPACITORS:		
C201	23S10255B30	5000, 20V; Lytic
C202	21S180B51	.001, 10%, X5F; Cer. Disc
C203	23S10255B82	100, 10V; Lytic
DIODES:		
D201	48S137670	Rectifier, Diode Module; 7670
D202	48S10641D43	Diode, Zener; 4.3V
FUSES:		
F201	65S139733	Fuse, 7A-125V
INTEGRATED CIRCUITS:		
IC201	51S1073201	Reference Amplifier; T3F
TRANSISTORS:		
Q201	48S137634	Transistor, Regulator; 7634
Q202	48S137169	Transistor, Regulator Driver; A6G
RESISTORS/CONTROLS:		
R206	18D25245A04	Control, +5V ADJ.; 4K
MECHANICAL PARTS:		
	7B25466A01	Bracket, Heat Sink (Q201)
	42S10122A12	Fuse, Clip; 2-Req'd. for F201
	14A562353	Insulator, Mica (Q201)
	14S10550A02	Insulator, Transistor Cover (Q201)
	2S10080A26	Nut, 6-32 x 5/16 (Mtg. D201)
	3S139702	Screw, Mch.; 6-32 x 5/8 (Mtg. D201)
	3S136050	Screw, Tpg.; 6-20 x 1/2 Clu Pan (Q201)
	9C63825A03	Socket, Power Transistor (Q201)

PARTS LIST FOR KV800A AUDIO MODULE (M5010/M7010)

REF. NO.	PART NUMBER	DESCRIPTION
CAPACITORS:		
C1	23S187A16	100, 16V; Lytic
C2	21S180F45	.015, 20%, 100V, Z5U; Cer. Disc
C3	23S187A16	100, 16V; Lytic
C4	23S10255B28	4.7, 100V; Lytic
C5	21S180B90	.01, 20%, 100V, Z5U; Cer. Disc.
C6	21S180B03	.02, 20%, Z5U, 500V; Cer. Disc.
C7	23S187A16	100, 16V; Lytic
TRANSISTORS:		
Q1	48S137171	Audio Driver; A6H
Q2	48S137648	Audio Output; 7648
RESISTORS/CONTROLS:		
R2	18D25245A30	Control, Volume; 10K
TRANSFORMERS:		
T1	25D25221A11	Audio Output
MECHANICAL PARTS:		
	42B25460A01	Clamp (Mtg. Ckt. Bd. to Spkr.)
	26C25198A02	Heat Sink (Q2)
	26C25198A04	Heat Sink (Q2)
S1	15S10183B09	Housing, Connector; Female (3-Contact)
	39S10184A83	Contact, Receptacle; 3-Req'd. for S1
	14A25461A01	Insulator, Washer; PC Board to Spkr. (LS1)
	2S10080A26	Nut, 6-32 x 5/16 (Mtg. Q2)
	3S138058	Screw, Mch., 6-32 x 3/8 (Mtg. Q2)
	50D25453A01	Speaker, P.M.; 4" x 4"

