

**IRONMAN**

Ivan Stewart's<sup>®</sup>

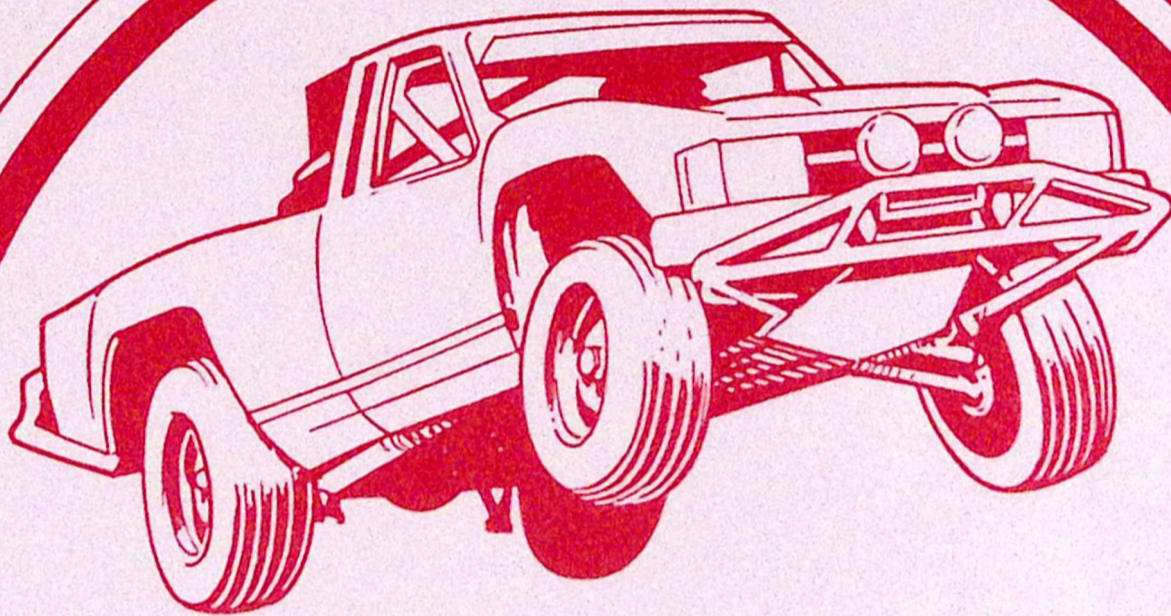

**OFF ROAD<sup>™</sup>**

*Leland*  
CORPORATION

**OWNERS MANUAL**

### **Your responsibility for maintenance**

It is the owner's responsibility to make sure that the specified maintenance is performed. The Troubleshootist's Section gives details of these maintenance requirements. Also included in the Troubleshootist's Section is information regarding other requirements for games operated under severe playing conditions.

### **Machine Information**

Purchase Date: \_\_\_/\_\_\_/\_\_\_

Distributor: \_\_\_\_\_

#### **Serial Numbers**

Program: \_\_\_\_\_  
(See lower left corner of Bookkeeping Main Menu screen)

Main Board: \_\_\_\_\_ Sub Board: \_\_\_\_\_

Cabinet: \_\_\_\_\_

Written and Illustrated  
by: **D.P.SABLE**

**PART NUMBER - 72-13606-22**

## FOREWARD

Welcome to the growing group of value conscious people who operate LELAND CORPORATION products. We are proud of the advanced engineering and quality of each game we build.

We invite you to read through this Owner's Manual. It is designed to acquaint you with the features of your new "Ivan 'Ironman' Stewart's SUPER OFF-ROAD" and to help you enjoy many miles/quarters of motoring/earning pleasure.

When it comes to service, remember that your authorized Leland distributor knows your game best and is interested in your complete satisfaction. He will provide quality parts, service, and any other assistance you may require.

### THE LELAND CORPORATION

Please leave the Owner's Manual in this game at the time of resale. The next owner will need this information also.

**All information and specifications in this manual are current at the time of printing. However, because of The Leland Corporation's policy of continual product improvement, we reserve the right to make changes at any time without notice.**

### NON-LELAND REPLACEMENT PARTS NOTICE

The Leland Corporation recommends the use of only Leland Corp. parts when replacing any malfunctioning component or assembly in your video amusement machine. For safety and reliability, The Leland Corp. does not recommend or authorize any substitution parts or modifications of Leland equipment. Such alterations may adversely affect game play or cause serious injury, and will void your warranty. Unauthorized parts and/or modifications may also void FCC compliance.

### FCC WARNING

This equipment generates, uses, and can radiate radio frequency energy and if not installed in accordance with the Owner's Manual, may cause interference to radio communications. It has been tested and found to comply with the limits for a class "A" computing device pursuant to subpart "J" of part 15 of the FCC rules, which are designed to provide reasonable protection against such interference when operated in a commercial environment. Operation of this equipment in a residential area is likely to cause interference, in which case the user, at his own expense, will be responsible to correct the interference.

**"Ivan IRONMAN Stewart's  
SUPER OFF-ROAD™  
TABLE OF CONTENTS**

<b>SECTION</b>	<b>PAGE</b>
<b>A. GENERAL GAME INFORMATION</b>	
1. Game Concept	1
2. Assembly Instructions	2
3. Warranty Information	4
4. Maintenance and Upkeep Procedures	5
<b>C. THE TROUBLESHOOTISTS SECTION</b>	
1. A Note About Power	6
2. Our Service Department	6
3. Troubleshooting Flow Chart	7
4. General Shooting	8
5. Monitor Shooting	8
6. Buffers	8
7. About Mechanical Coin Counters	9
<b>D. ILLUSTRATED PARTS LIST</b>	
1. Cabinet	10
2. Controls (buttons, foot pedals, steering wheels, etc.)	11
<b>E. WIRING DIAGRAMS</b>	
1. Main Board	12
2. Multi-Function Board	14
3. Cabinet	16
<b>F. BOOKKEEPING AND DIAGNOSTICS SECTION</b>	
1. Main Menu - Bookkeeping - Diagnostics Menu	17
2. Video Alignment Screens	21
3. Game Set-Up - Game Statistics	23
<b>E. SCHEMATICS &amp; BOARD LAYOUTS</b>	
1. Multi-Function Board Layout (top board)	27
3. Multi-Function Board Schematics	28
4. Main Board Layout (bottom board)	38
5. Main Board Schematics	39
6. 25" Wells Gardner Monitor	58

**"Ivan IRONMAN Stewart's  
SUPER OFF ROAD™  
GAME CONCEPT**

In his never ending quest for adventure and excitement, man invented off-road racing. These races were then brought before the masses by converting huge sports stadiums into dirt and mud obstacle courses in which off-road "Ironmen" battled for top honors.

Now **THE LELAND CORPORATION** brings this fast moving, hard driving sport to the video game arena.

**"Ivan IRONMAN Stewart's SUPER OFF-ROAD™** is stadium off-road racing at it's best. One to three players are asked to test their dirt track skills against the best dirt truck driver in the world.

Contestants compete on 8 different tracks with a total of 16 configurations and these courses are packed with enough jumps, bumps, hills, and holes to challenge even the most skillful driver.

Winning drivers earn "cash" prizes, and use this "cash" to "buff out" their machines. At the end of each race, players take their trucks to the "Speed Shop" to buy better shocks, tires, engines, and higher top speed. They can also buy nitro packs to help them blast over the jumps and through the mud.

The **"Convert-a-Credit™** feature allows drivers to add to their winnings by using credits as "cash". Each additional quarter, when converted, becomes \$200,000.00 in game "cash" and this additional "cash" may be used for purchases in the "Speed Shop".

Team Leland's **"Ivan IRONMAN Stewart's SUPER OFF-ROAD™** has the depth and variety to be an Income 'winner' for years to come.

"Ivan IRONMAN Stewart's  
*SUPER OFF-ROAD*"™  
CABINET ASSEMBLY ILLUSTRATION

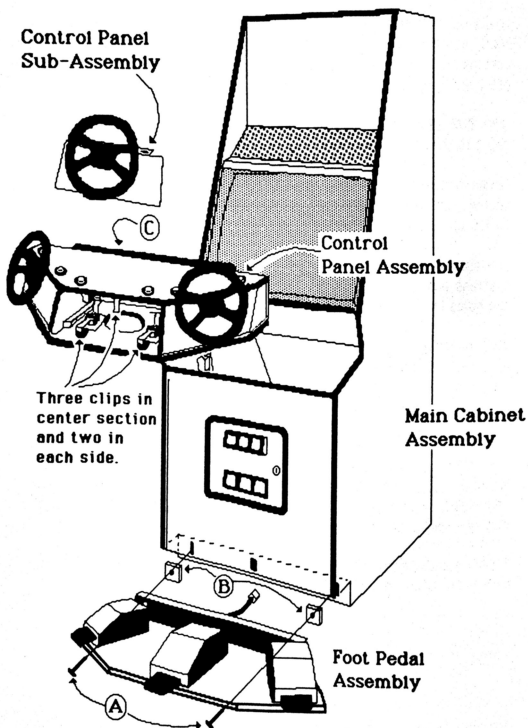

## ASSEMBLY INSTRUCTIONS

1. Remove all parts from shipping containers and check them for damage. Notify your distributor (and the shipper) **immediately** if you find any broken parts.
2. Detach and remove the pedal assembly from the inside of the main cabinet. Remove the two bolts **(A)** and blocks **(B)** from the bottom front of the main cabinet.
3. At this point, it is a good idea to lift the monitor plex and clean or dust from the monitor any debris which may have settled in shipment.
4. Remove the center (yellow) steering section from the control panel assembly by reaching through the hole in the bottom of the assembly and unfastening the three clips inside. Attach the monitor plex retainer **(C)** to the control panel assembly. (The wing nut should be loose until the control panel assembly has been attached to the game cabinet.)
5. Position the control panel with the harness connectors hanging into the main cabinet and secure the panel to the main cabinet by reaching through the front door and attaching the four clips provided.
6. Connect the control panel harness to the main harness, tighten the wing nut on the monitor plex retainer and reinstall the center steering section.
7. Feed the pedal harness through the center hole in the lower part of the cabinet and attach the pedal assembly using the bolts **(A)** and blocks **(B)** removed in step 2. **REMOVE THE PEDAL ASSY. WHEN TRANSPORTING THE GAME.**
8. Check through the cabinet for loose wires. Plug the game in and power-up. Check for smoke.
9. Go through all diagnostics and game set-up procedures and **PLAY THE GAME**. If it works - don't fix it, just get it out there and

***Do it in the dirt!***

*Please call our Customer Service Department with any questions or comments.*

## THE LELAND CORPORATION WARRANTY

The Leland Corporation warrants that whenever the video display (monitor) and/or the power supply and/or the printed circuit boards and/or all parts contained therein are furnished with its product, that such part or parts will be free from all defects in materials and workmanship for a period of sixty (60) days from the date of shipment. The Leland Corporation's warranty of above parts is subject to the normal use and service of its product. No other products or parts thereof are warranted. If the products described in this manual fail to conform to this warranty, The Leland Corporation's sole liability shall be, as mutually agreed, to replace or repair such products which are returned to The Leland Corporation during stated warranty period, provided:

- A. The Leland Corporation is notified *in writing* upon discovery by the buyer that said products are defective.
- B. The defective product or part is returned *pre-paid* to The Leland Corporation's plant with a Leland Corp. Returned Merchandise Authorization (RMA) number clearly visible on the outside of the package.
- C. The Leland Corporation's examination of the returned product(s) or part(s) determines, to our satisfaction, that the alleged defects existed and were not caused by accident, misuse, neglect, alteration, improper repair, installation, or testing.

The Leland Corporation is not responsible for bent pins on ICs not installed by our employees. In no event shall The Leland Corporation be liable for loss of profits, loss of use, or incidental or consequential damages.

**EXCEPT FOR THIS WARRANTY, THE LELAND CORPORATION DISCLAIMS ALL OTHER WARRANTIES, EXPRESSED OR IMPLIED, INCLUDING THE IMPLIED WARRANTIES OF MERCHANTABILITY AND FITNESS FOR A PARTICULAR PURPOSE, AND ALL OTHER OBLIGATIONS OR LIABILITIES ON THE LELAND CORPORATION'S BEHALF, AND IT NEITHER ASSUMES NOR AUTHORIZES ANY OTHER PERSON TO ASSUME FOR THE LELAND CORPORATION ANY OTHER LIABILITIES IN CONNECTION WITH THE SALE OF PRODUCTS MANUFACTURED BY THE LELAND CORPORATION.**

## MAINTENANCE AND UPKEEP PROCEDURES FOR

"Ivan IRONMAN Stewart's

***SUPER OFF-ROAD™***

BY THE LELAND CORPORATION

Any off-road driver will tell you that, without a Pit Crew, he might as well not have a truck. The same is true of your Super Off-Road game. If you don't keep up with your "Pit Crew" responsibilities, your game's performance will suffer drastically.

A dirty or improperly adjusted monitor, a sticky coin mech, or poorly adjusted player controls are all suspect when a drop in revenue is noticed.

The following are recommended standard procedures when servicing your machine:

### 1. Every collection -

- a. Make sure the cabinet and especially the control panel are clean and free of gum, grease, and dirt.

Play the game. Check the steering wheels, foot pedals, and buttons for proper adjustment and operation. (See the Buttons and Controls test in the Diagnostics section.)

NOTE: Be sure to adjust, clean, or replace any marginal switches. One drop of oil or graphite will keep steering wheels from squeaking.

- c. Clean and adjust the monitor so that the picture is "rich" and inviting.

### 2. Once a month -

- a. Check the inside of the cabinet for dirt and dust.

HINT: Carry a portable "Dustbuster" type vacuum.

- b. See that all connectors are properly seated.

- c. Be sure that the power supply is up to snuff. (Refer to "A Note About Power" for proper settings.)

Go through all diagnostic functions to insure proper operation and inspect game settings.

At first these steps may seem cumbersome or excessive but when viewed with respect to the income generated by a clean, well-maintained machine, as opposed to the income lost by a dirty, "trashed" game, the benefit of spending those few extra minutes will be seen as a wise investment.

# THE TROUBLESHOOTIST'S SECTION

## A NOTE ABOUT POWER

### DC POWER

The computer board in this machine operates most efficiently when the power supply is providing a steady + 5.20VDC ( +0.1VDC). When checking DC power always put your leads across the power inputs on the main board and be sure that the +5 volt supply is between +5.20VDC and +5.24VDC. Also be sure that there is less than .005 volts AC riding on the +5 volt line. If you do find AC on the DC line, suspect the filter capacitor or the rectifier on the power supply. Low voltage and AC on the DC lines are the main causes of the following problems:

- \* "Garbage" on the screen.
- \* Computer "Freeze".
- \* Coin or Coin Meter malfunction.
- \* A variety of seemingly unrelated problems.

### AC POWER

Connect this game only to a grounded three-wire outlet which provides between 108 and 132 volts AC. If you have only a two-wire outlet we recommend that you hire a licensed electrician to install a grounded outlet. The possibility exists that players may receive an electrical shock if this system is not properly grounded.

## OUR SERVICE DEPARTMENT

For parts, service, and technical information first contact your authorized Leland Corporation distributor. For additional technical aid feel free to contact the Leland Corp. Customer Service Department at *(619)562-7000* Monday through Friday from **8:00 AM to 5:00 PM Pacific Standard Time.**

To provide you with the quickest possible response to your questions, please have the following information ready when you call:

- 1. Your game name and serial number.**
- 2. Any reference materials and a list of observations.**

## TROUBLESHOOTING FLOW CHART

**DON'T TOUCH THAT SWITCH !!!**

Before you reach for the power switch take a good look at the game. Open it up and check for loose wires, bad connections, or burned spots. Look for spilled drinks and signs of vandalism. Those quick checks will save you a lot of time.

After you've eliminated the obvious, start digging.

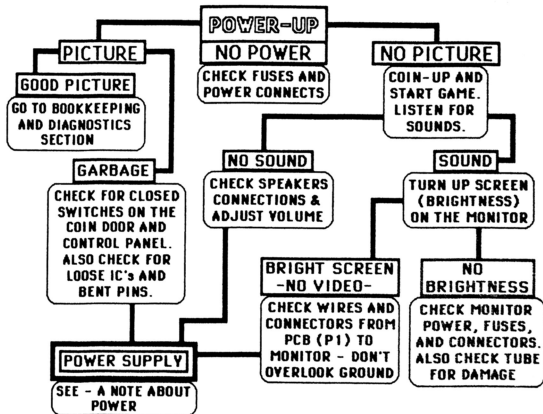

Never take anything for granted. This is easy to do if you are in a hurry --- You'll kick yourself every time for missing a broken wire or loose connector after spending hours looking in the wrong place - I have.

## GENERAL SHOOTING

### GARBAGE

Check: Power supply voltages.  
Closed switches on the control panel or coin door.  
Loose connections, loose IC's, or bent pins on the board.

### NO SOUND

Check: Loose connections.  
Low +12VDC supply.  
Bad speaker or volume pot.

### NO CONTROL OR FUNCTION SWITCHES (Includes coin switches)

Check: All Connections. (Especially ground)  
Wire continuity between board and switch.  
Closed or broken switches.  
Input buffers. (See BUFFERS.)

## MONITOR SHOOTING

### NO PICTURE

Check: Power connection.  
Monitor fuses.  
Video connections. (Check continuity.)

### SYNC PROBLEMS

Check: Sync and ground connections. (See WIRING DIAGRAM)  
Sync polarity.  
Video output buffer.

## BUFFERS

An input or output (I/O) buffer is the component that connects the actual game computer to the outside world and, as such, is the part most likely to fail. Check the following list when attempting to isolate possible problems. First and second choices are given. (M=Main Board, I/O= Multi-Function Board.)

***NOTE: ANY UNAUTHORIZED BOARD REPAIR OR ATTEMPTED REPAIR  
WILL VOID YOUR WARRANTY.***

<b>PROBLEM AREA</b>	<b>COMPONENT</b>	<b>PCB LOCATION</b>
VIDEO (Colors or Sync)	1 <sup>st</sup> 7405 or 74S05 2 <sup>nd</sup> 74LS374	M-U24 M-U37
PLAYER CONTROLS and/or COIN CONTROLS	1 <sup>st</sup> 150 ohm resistor pack. 2 <sup>nd</sup> 74LS257	See Wiring Diagram & Schematics for specific switch.
AUDIO (Bad channel)	1 <sup>st</sup> 7524  2 <sup>nd</sup> 7533	I/O-U35(ch5) through U40 (ch0) I/O-U31

## ABOUT MECHANICAL COIN COUNTERS

We have not installed mechanical coin counters on this game for two reasons:

1. The bookkeeping program is extremely accurate and includes not only number of coins dropped and dollars earned but also the number of tests and coins in a given period. (See BOOKKEEPING in the DIAGNOSTICS section.)
2. These mechanical coin counters produce an inductive "kick" that *will* damage components on the circuit board. Checkerboard video is the most common problem. If this is, in fact, your problem - take a look at the "NMI not" signal on the master Z80 (pin 17). If a low output is observed, try replacing U114 (74LS08) and/or U119 (74LS157).

*NOTE: If you must install a mechanical coin counter, please use the following diagram. (Diodes may be 1N4001 to 1N4004.)*

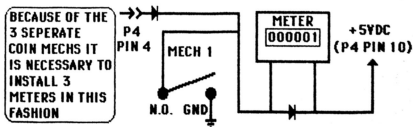

**"Ivan IRONMAN Stewart's  
SUPER OFF-ROAD"™  
ILLUSTRATED PARTS LIST**

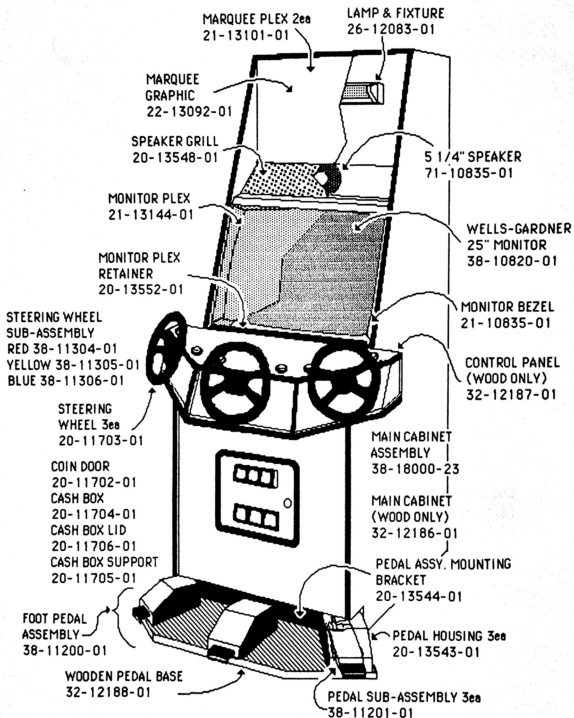

# OTHER PARTS

## CONTROL PANEL

PANEL TOP OVERLAY 22-14924-01  
SUB-PANEL OVERLAYS

RED - 22-14921-01  
YELLOW - 22-14922-01  
BLUE - 22-14923-01

BUTTON - MICRO 2ea

RED - 37-11194-01  
YELLOW - 37-11196-01  
BLUE - 37-11195-01

LATCH 11ea - 20-10867-01  
(7 inner panel and 4 cabinet)

## STEERING ASSEMBLY

METAL PANELS

RED 20-13549-01  
YELLOW 20-13550-01  
BLUE 20-11551-01

ENCODER WHEEL

25-11007-01  
LARGE GEAR 25-11008-01  
SMALL GEAR 25-11009-01

## MISCELLANEOUS

ON/OFF SWITCH - 37-10894-01  
VOLUME POT - 51-12501-01  
LEG LEVELER - 20-13530-01

## PEDAL ASSEMBLY

SHOULDER BOLT  
4"x1/2" STAINLESS  
25-18251-01  
POTENTIOMETER  
51-12502-01  
ARMATURE  
20-13540-01  
SPRING - 20-15061-01

## ELECTRONICS

PCB ASSEMBLY COMPLETE  
38-11695-22  
MAIN (BOTTOM) PCB  
81-12170-14  
MULTI FUNCTION #2 (TOP) PCB  
81-18002-22

STEERING OPTO COUPLER PCB  
80-20000-01

## POWER SUPPLY

ISOLATION TRANSFORMER  
43-11704-01  
SWITCHING POWER SUPPLY  
82-12150-01  
LINE FILTER - 63-12131-01  
POWER CORD - 87-12143-01

TO  
MONITOR

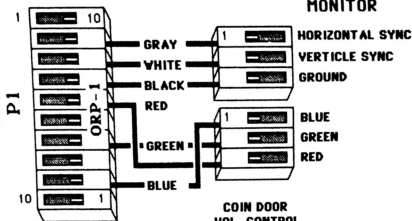

## MAIN WIRING DIAGRAM (MAIN BOARD)

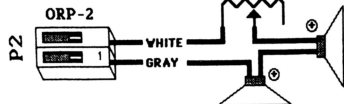

TOP (MULTI-FUNCTION) PCB

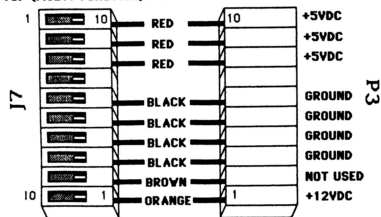

*NOTE: SYSTEM PIN-OUT  
OPPOSITE OF PIN-OUT  
MOLDED IN HARNESS  
CONNECTORS.*

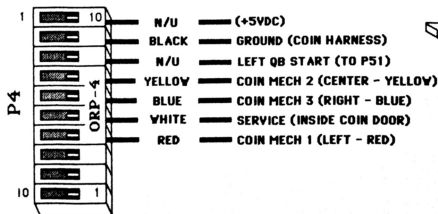
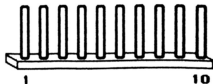

CP-5 SP-5

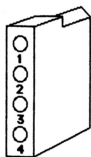
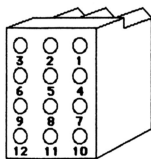
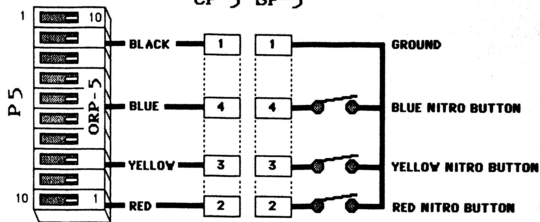

*MALE MOLEX CONNECTORS  
TYPICAL PIN-OUT*

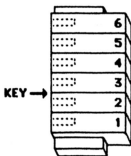
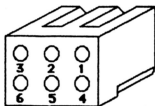
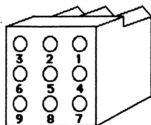

*STEERING WHEEL  
CONNECTOR*

*SEE MAIN BOARD LAYOUT  
FOR BOARD CONNECTOR  
LOCATIONS.*

# MAIN WIRING DIAGRAM (MULTI-FUNCTION BOARD)

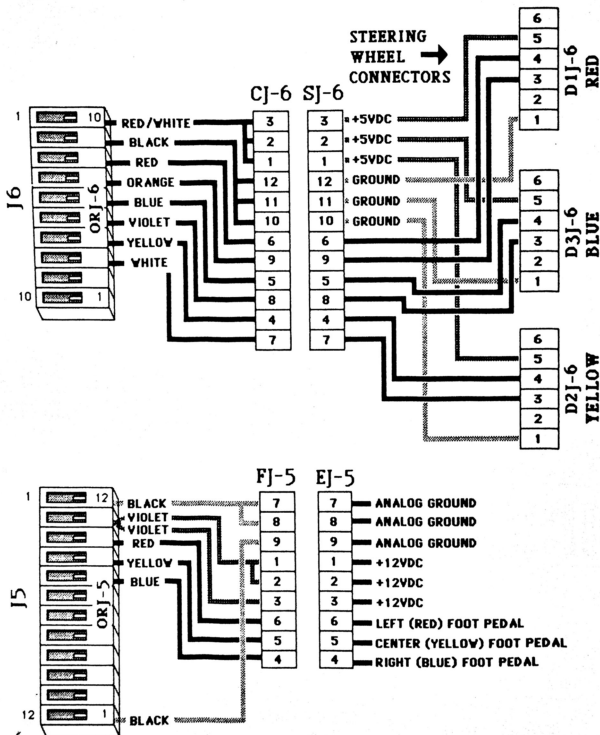

**FROM SWITCHING  
POWER SUPPLY**

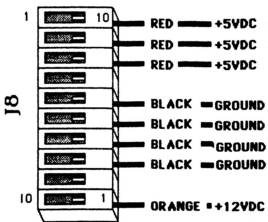

**SEE P7 ON MAIN BOARD  
WIRING DIAGRAM**

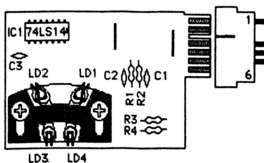
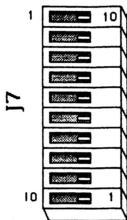

**STEERING OPTO-  
COUPLER PCB  
CONNECTION**

**FOOT PEDAL  
POTENTIOMETER  
HOOK-UP**

12VDC (VIOLET)  
 CONTROL  
(CAR COLOR)  
 GROUND (BLACK)

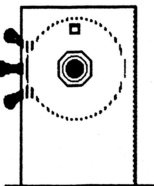

# CABINET WIRING DIAGRAM

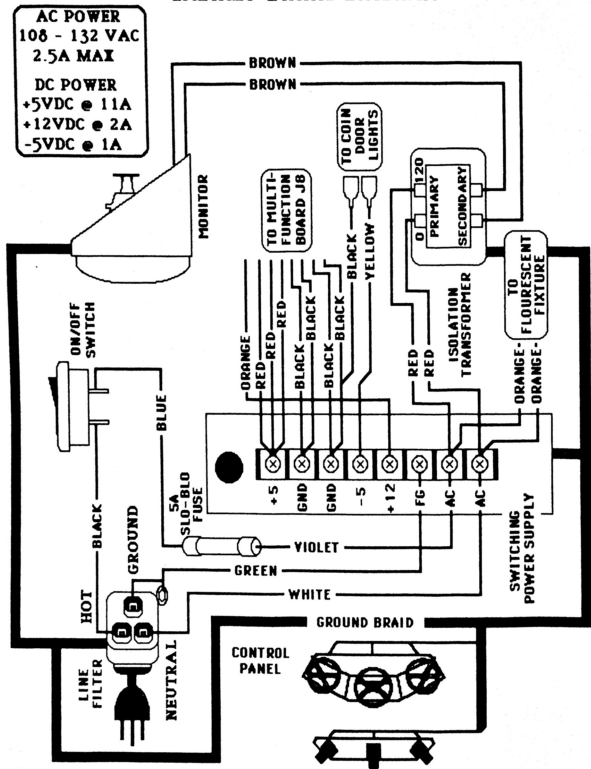

## BOOKKEEPING AND DIAGNOSTICS SECTION

To enter the Bookkeeping and Diagnostics Section:

- \* With the **Blue Nitro** button depressed, press the **Test** button located inside the front door on the left.

Upon entering the program, the **Main Menu** will appear (Figure 1). Follow the instructions on this menu to select and enter the desired function.

### Bookkeeping (Figure 2)

The Bookkeeping function is your game accountant. It records the lifetime earnings of your game and allows you, through the use of resettable "Period" totals to keep track of weekly, monthly, or location earnings. This function also separates the readings by coin mech. If one of the coin mech readings is disproportionately low, you may suspect that your players are having trouble with either that mech or the controls of the car associated with that mech.

**NOTE:** The "SET COINS/TOKENS PER DOLLAR" category must be set to the location standard to maintain accurate accounting data. (i.e. 6 COINS/TOKENS PER DOLLAR.)

**THIS FUNCTION DOES NOT AFFECT THE NUMBER OF COINS PER CREDIT - SEE THE "GAME SET-UP" SECTION FOR COINS PER CREDIT INFORMATION.**

### Diagnostics (Figure 3)

You will notice the Diagnostics Section has a sub-menu of its own. Invoking the Diagnostics function will open a complete and easy to use set of tests designed to take the grumbling and hair pulling out of adjusting, troubleshooting, and servicing your machine.

### Buttons and Controls Test (Figure 4)

This test provides a quick examination of the state of all buttons and controls as well as an easy range and direction setting format for the steering and pedal controls. As shown on the screen, the **minimum** setting for any foot pedal assembly is between **0 and 80**. Each pedal must also be able to achieve the **maximum** setting of **255** when fully depressed.

### Processor Memory Test (Figure 5)

The Erasable Programmable Read Only Memory (EPROM) and Random Access Memory (RAM) IC's are storage areas for the actual game guidelines and are accessed by the Microprocessor section.

### MAIN MENU

SELECT FUNCTION WITH RED NITRO BUTTON  
ENTER FUNCTION WITH BLUE NITRO BUTTON

BOOKKEEPING  
DIAGNOSTICS  
GAME SET-UP  
GAME STATISTICS  
GAME DURATION STATISTICS

RESTART THE GAME

CANCEL CHANGES AND RESTART GAME

FIGURE 1

### BOOKKEEPING

SELECT FUNCTION WITH RED NITRO BUTTON  
ENTER FUNCTION WITH BLUE NITRO BUTTON

	LIFETIME	PERIOD	
	COINS	COINS	DOLLARS
COINS DROPPED - MECH 1	100	100	\$25.00
- MECH 2	100	100	\$25.00
- MECH 3	100	100	\$25.00
TOTAL COINS DROPPED	300	300	\$75.00
TOTAL CREDITS GIVEN =			
- MECH 1	100		
- MECH 2	100		
- MECH 3	100		

RESET COIN MECH 1 DOLLARS COLLECTED

RESET COIN MECH 2 DOLLARS COLLECTED

RESET COIN MECH 3 DOLLARS COLLECTED

SET COINS/TOKENS PER DOLLAR:

4 COINS PER DOLLAR COIN MECH

RETURN TO MAIN MENU

FIGURE 2

### DIAGNOSTICS

SELECT FUNCTION WITH RED NITRO BUTTON  
ENTER FUNCTION WITH BLUE NITRO BUTTON

BUTTONS AND CONTROLS TEST

PROCESSOR MEMORY TEST

VIDEO ALIGNMENT SCREENS

AUDIO SUBSYSTEMS TEST

VIEW BACKGROUND SCREENS

RETURN TO MAIN MENU

FIGURE 3

PLEASE PRESS THE FOLLOWING BUTTONS:

NITRO 1 BUTTON <RED>	CLOSED
NITRO 2 BUTTON <YELLOW>	OPEN
NITRO 3 BUTTON <BLUE>	OPEN
MECH 1 COIN SWITCH	OPEN
MECH 2 COIN SWITCH	OPEN
MECH 3 COIN SWITCH	OPEN
SERVICE SWITCH	OPEN

INDICATES PRESSED  
OR STUCK SWITCH

\*\*\* MINIMUM = 0-80

MAXIMUM = 255 \*\*\*

GAS PEDAL 1 = 60

GAS PEDAL 2 = 72

GAS PEDAL 3 = 54

STEERING WHEEL 1 =

STEERING WHEEL 2 = CLOCKWISE TURN

STEERING WHEEL 3 = COUNTER-CLOCKWISE TURN

PRESS SERVICE OR BLUE NITRO BUTTON TWICE TO EXIT

STEP ON PEDALS TO  
CHECK SETTINGS

TURN WHEELS TO  
MOVE DIAMONDS

FIGURE 4

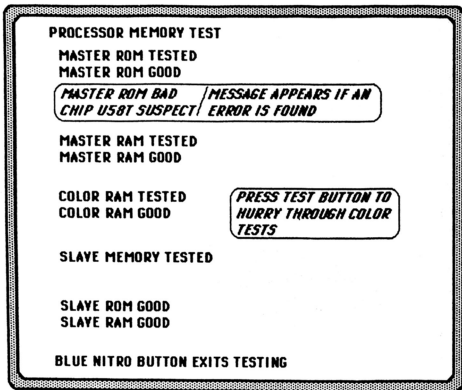

FIGURE 5

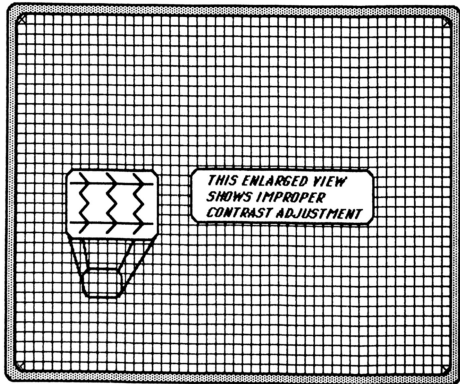

FIGURE 6

## Processor Memory Test (cont.)

The percentage of field failures in these areas is very low, but when a problem does arise, it can be a bear to track down. This test samples the action of the processor section and notes any incongruities.

**WARNING: READ YOUR WARRANTY BEFORE ATTEMPTING ANY PRINTED CIRCUIT BOARD REPAIRS.**

## Video Alignment Screens

The picture on the screen is the most important and most neglected part of the game. It is a proven fact that a dirty, misaligned, or unfocused screen will cause a player to walk away even if the game is his/her favorite piece. A little elbow grease and a couple of minutes spent going through these adjustment screens will make a big difference in the cashbox. Use all three screens to adjust your picture and then go to the "Background Screens" section to make the game look *"rich"*.

### Cross-Hatch Screen (Figure 6)

Used to adjust focus, alignment, size (note x's in the corners) and contrast. Wavy vertical lines (see inset) denote bad contrast.

The background should be black and the lines solid white.

If there appears to be an area of color on the screen (usually in one of the corners), your monitor probably needs "degaussing".

This condition is caused by moving the game with the power on.

Although the monitor contains an internal degaussing mechanism, this mechanism might take a while to work and may not completely cure the problem. I recommend that you purchase a

"degaussing coil" and carry it in your service vehicle. Degaussing doesn't take much time and it makes a big difference.

### Red and Green Screen (Figure 7)

Adjust the screen or brightness control so the green color bar shows **faintly** on the 1 level and use the red cutoff control to adjust the red bar to the same intensity.

### Blue and Miscellaneous Screen (Figure 8)

Use the blue cutoff control to make the gray color appear gray (not brownish). Adjust the red and green drive controls slightly, if necessary, to make the white block white.

## Audio Subsystems Test (Figure 9)

The sounds are the second most important feature of any game and in a game like "Super Off-Road" are essential to the feel of the game.

The volume of sound is, for the most part, dictated by the location and is thus a "given" but the quality of sound is a function of the program.

This test will be of help in your quest to find those "odd" sounds or to remedy the lack of certain sounds.

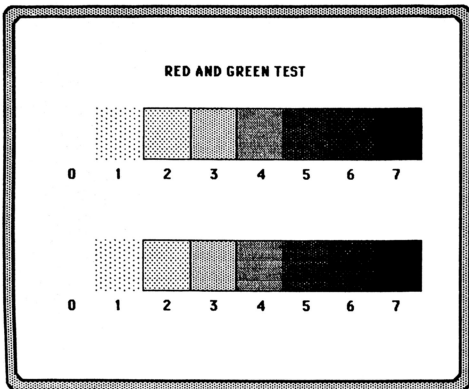

**FIGURE 7**

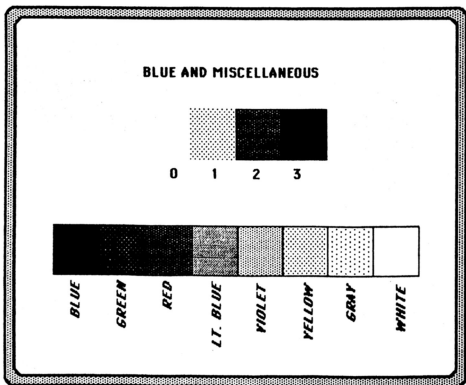

**FIGURE 8**

### **Background Screens (Figure 10)**

In this test, the background screens are shown while the EPROMs which contain the information for these screens are displayed at the top of the picture. This test is not only helpful when looking for those "glitches" one sometimes encounters, but may also be viewed as a visual test of the colors and picture clarity after the "Video Alignment" test has been completed.

### **Game Set-Up (Figure 11)**

The "Game Set-Up" or "Operator Adjustable" section is vital to the condition of your cash box. When used in conjunction with the "Bookkeeping" and "Statistics" sections of this diagnostics package, the "Game Set-Up" function will keep this game on your list of top earners for years to come. The **Coins-per-Credit** settings range from 1 coin for 1 credit to 20 coins for 20 credits. (*0 coins for 1 credit sets the game on "free play".*)

#### **SOME SOUND ADVICE:**

**THOSE ANNOYING ATTRACT MODE SOUNDS ARE SUPPOSED TO DRAW ATTENTION.**

#### **LET THEM !**

The **Difficulty** level may be set from 1 to 8. Our tests show that level 4 is the best all-around starting point.

After entering their initials and birth date each player is asked to choose the country for which he/she will race. The operator may select one of the countries listed to better suit his game to a particular location.

### **Game Statistics (Figure 12) & Game Duration Statistics (Figure 13)**

These two sections are your game "Report Card". Check these sections for glaring discrepancies. Many "starts" and few "joins" or "continues" on any one car could be an indication of a control or coin mech problem.

Unlike many games, whose best income is a result of a 2 to 2.5 minute average game time, collections from **"SUPER OFF-ROAD"™** are highest when the average game time is between 3.25 and 3.75 minutes. Your players get more for their money!

### **Country Selection (Figure 14)**

When a player begins a game, he or she is given a choice of countries for whom he or she will race. This section allows you to further customize your game by choosing which eight countries will appear on the country selection screen. You may also choose a preselected list of American or European countries.

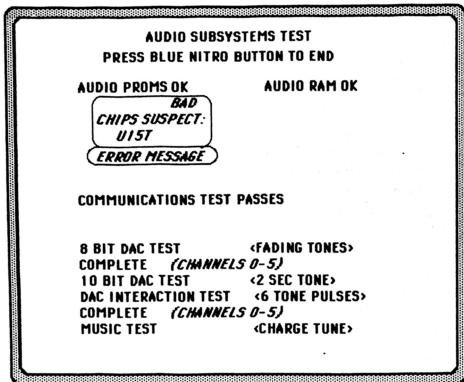

FIGURE 9

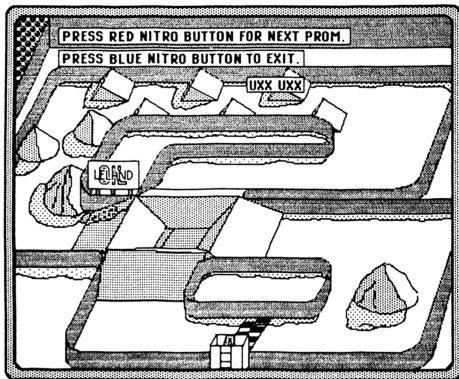

FIGURE 10

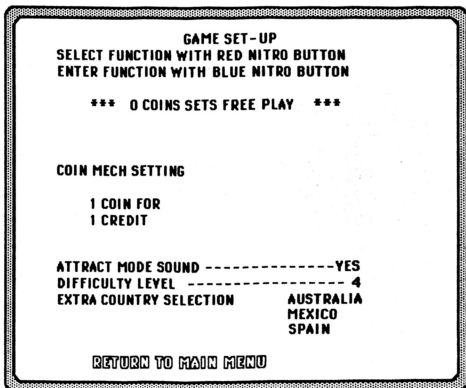

FIGURE 11

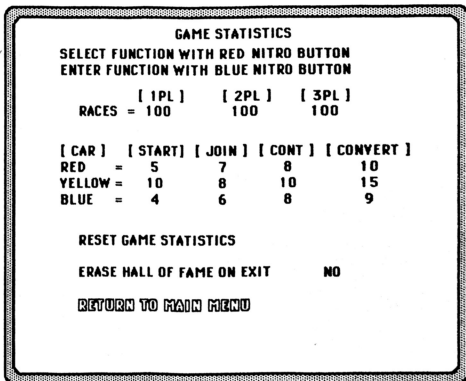

FIGURE 12

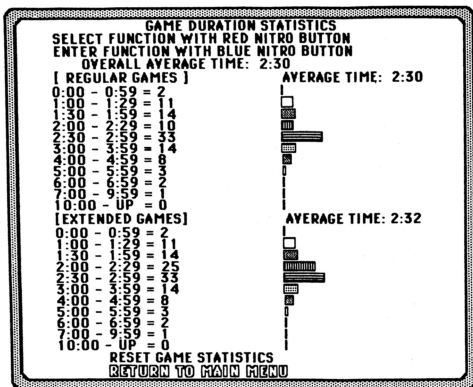

FIGURE 13

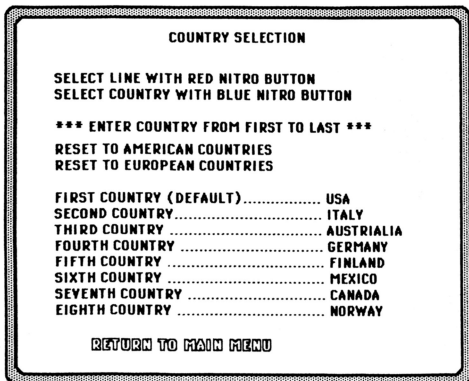
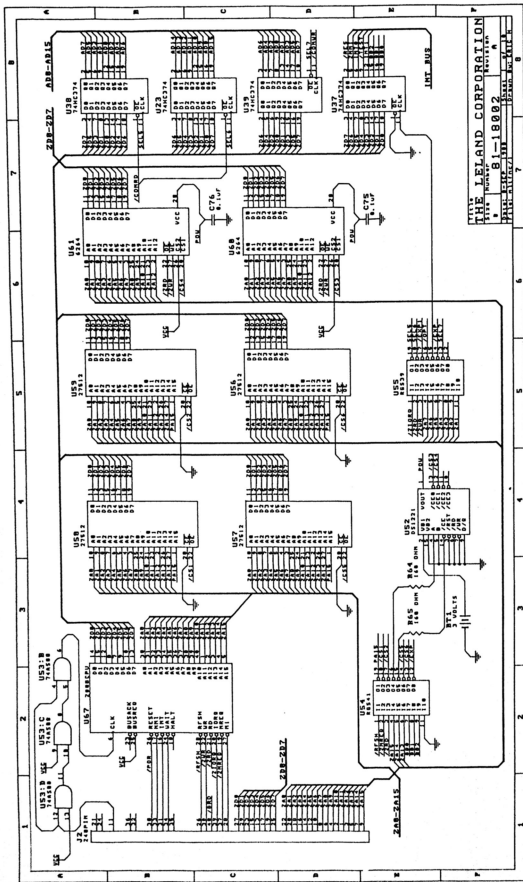
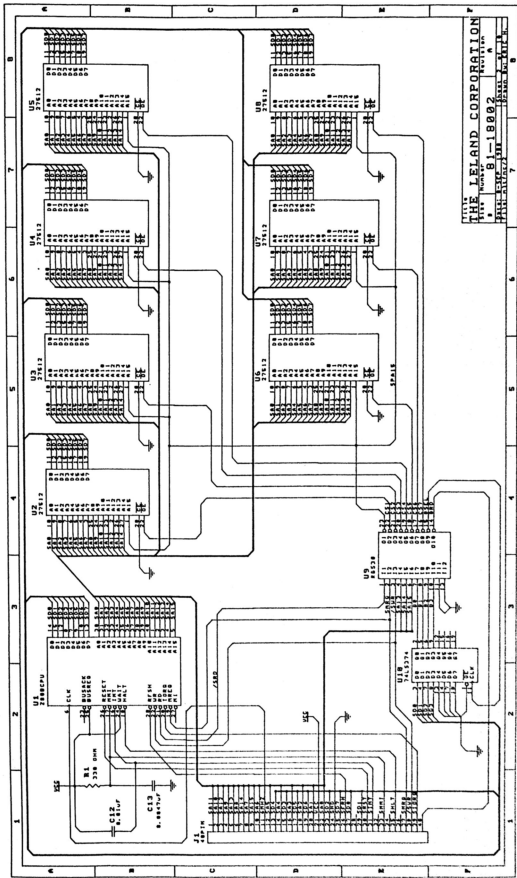

FIGURE 14





THE IRLAND CORPORATION  
 81-1802  
 PART 1176/1181  
 DRAWING NO. 1176/1181



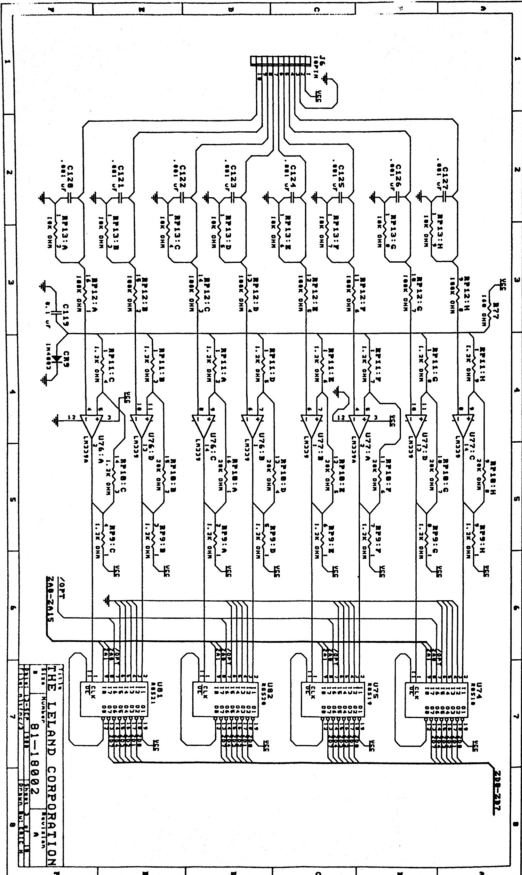

THE  
 IRLAND CORPORATION  
 81-1802  
 NEW YORK, N. Y.  
 MADE IN U.S.A.



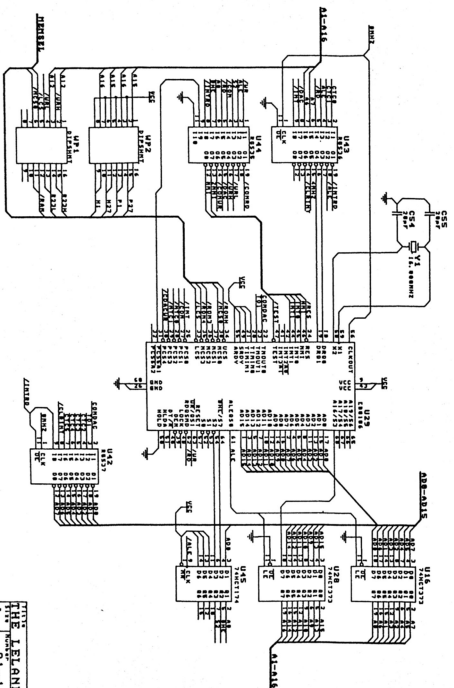

THE IELAND CORPORATION  
 81-1802  
 MADE IN U.S.A.  
 PRINTED IN U.S.A.

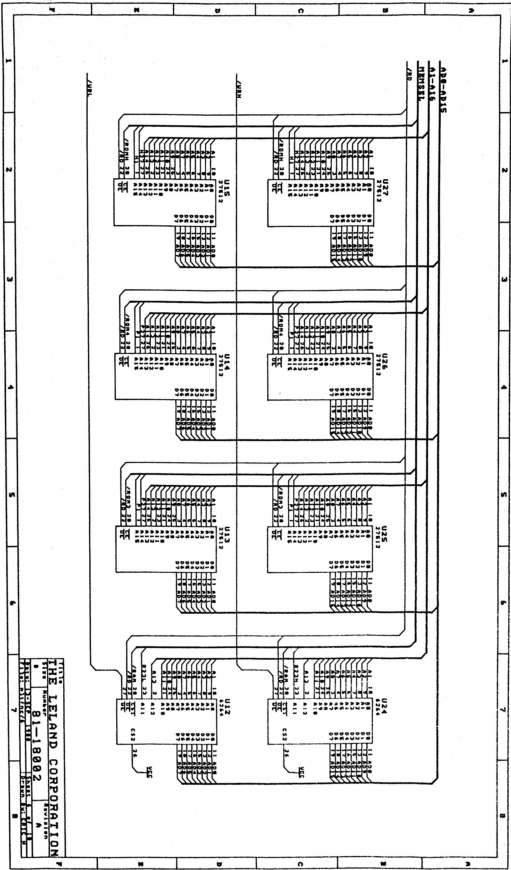

THE LELAND CORPORATION  
 81-1882  
 7











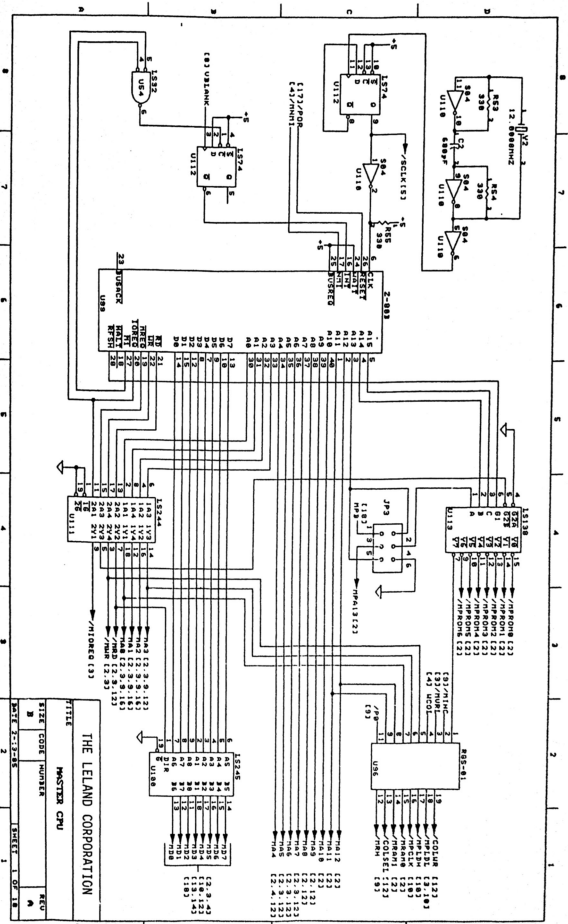

THE LELAND CORPORATION  
 HAMSTER CPU  
 TITLE  
 SIZE CODE NUMBER  
 DATE 7-1-75  
 SHEET 1 OF 18  
 REV

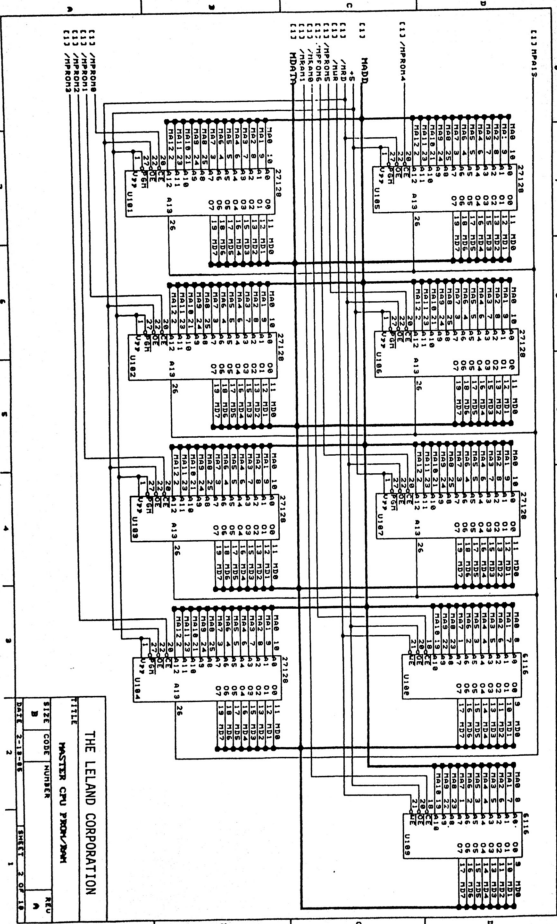

**THE LELAND CORPORATION**

TITLE: MASTER CPU PROM/ROM

SIZE CODE NUMBER: A

REV: A

DATE: 3-11-88

SHEET: 3 OF 10

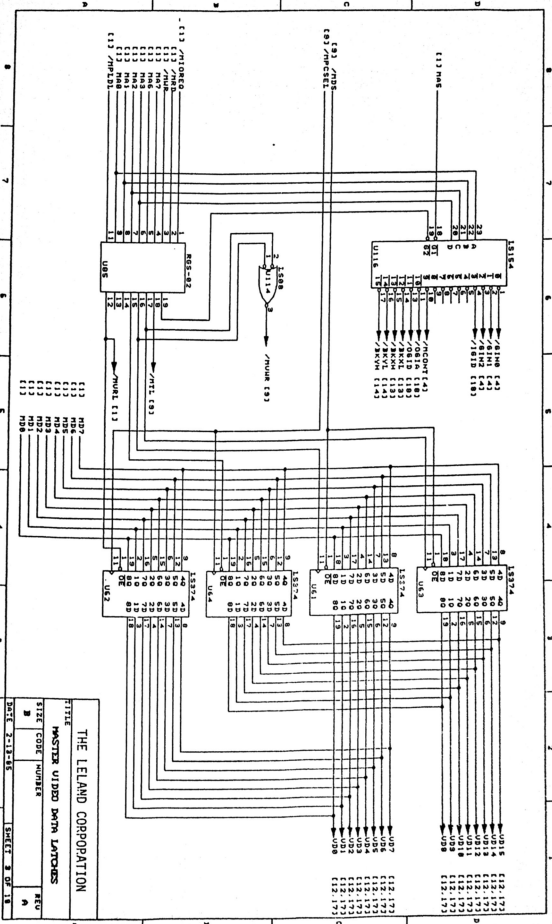

THE LELAND CORPORATION

MASTER VIDEO DATA LAYOUTS

SIZE CODE NUMBER

REV

DATE 2-13-85

SHEET 3 OF 18

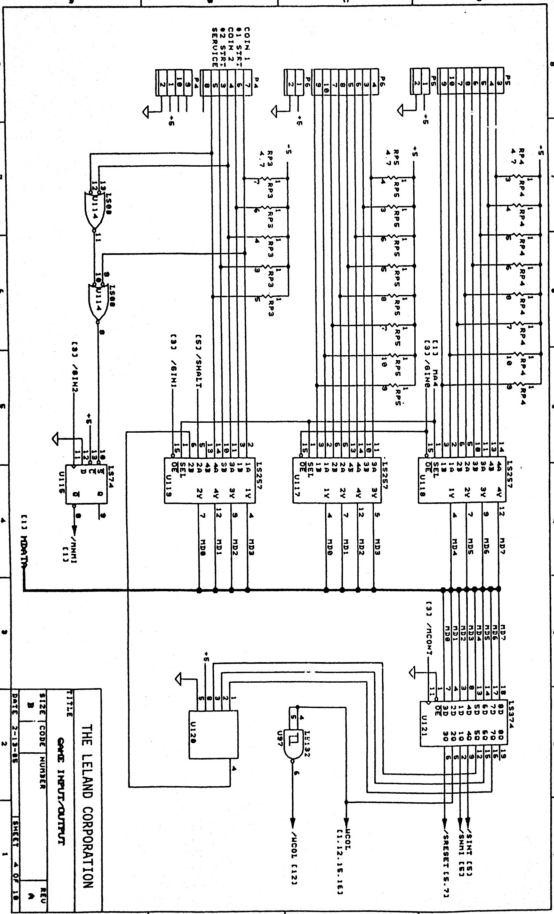

THE LELAND CORPORATION  
 GAGE INPUT-OUTPUT  
 TITLE  
 SIZE CODE NUMBER  
 DATE 2-13-58 SHEET 4 OF 18



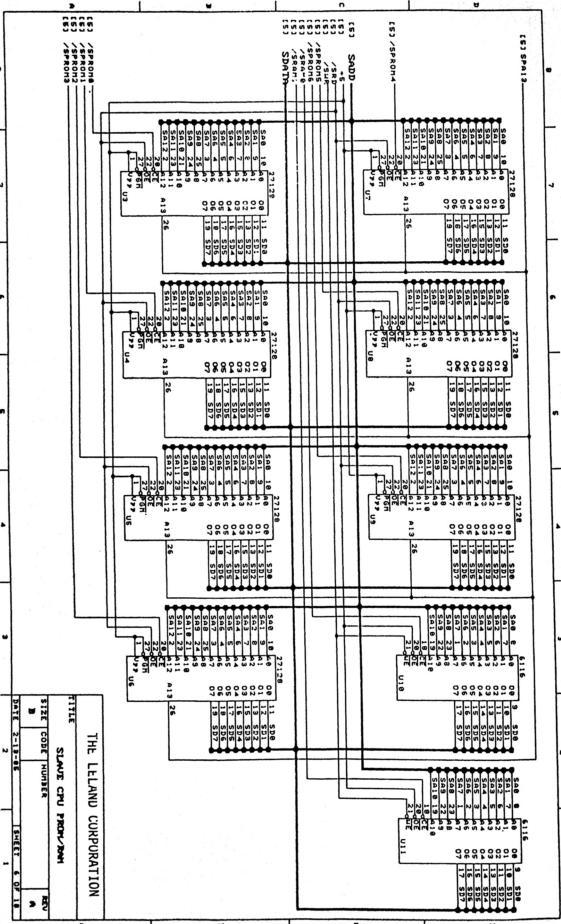

**THE LELAND CORPORATION**

TITLE SLAVE CPU PDM/SM

SIZE CODE NUMBER REV

DATE 2-18-85 PAGE 4 OF 18









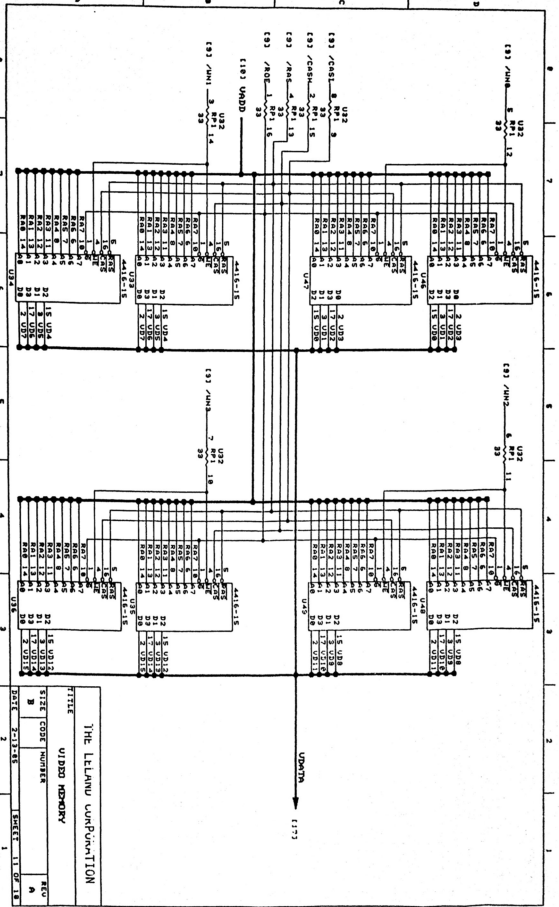

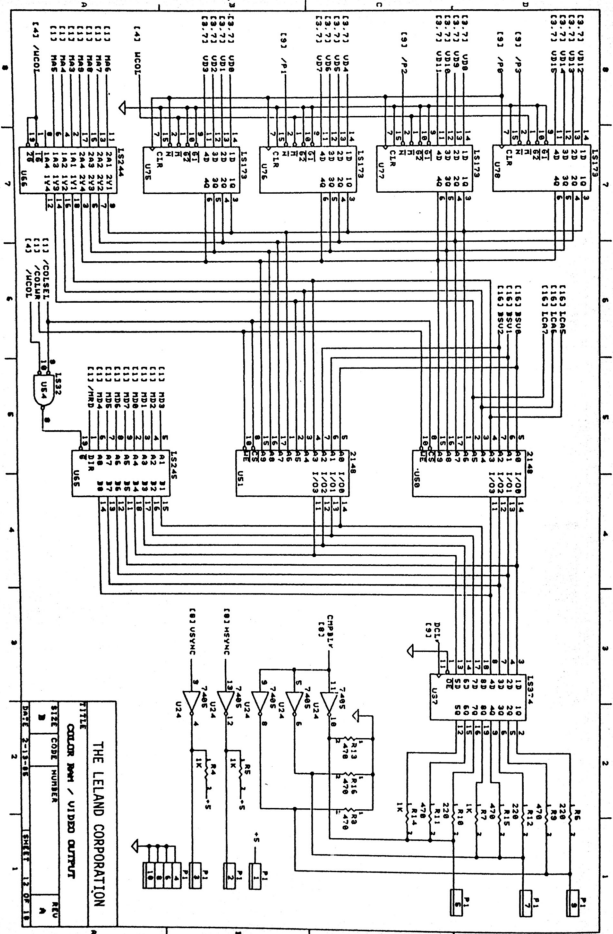

THE LELAND CORPORATION  
 COLOR INVT / VIDEO OUTPUT  
 TITLE  
 COLOR INVT / VIDEO OUTPUT  
 SIZE CODE NUMBER  
 DATE 2-13-78 SHEET 13 OF 18

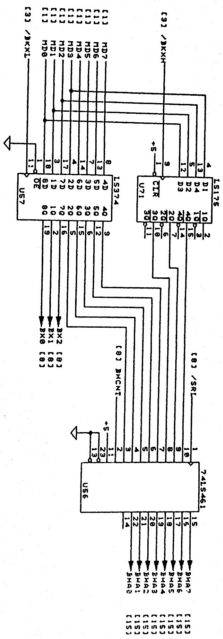

SPACE GATES

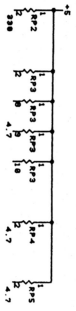
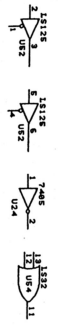

THE LELAND CORPORATION	
TITLE	
BACKGROUND HORIZONTAL ADDRESS	
SIZE	CODE NUMBER
REV	
DATE: 2-13-88	SHEET 13 OF 18

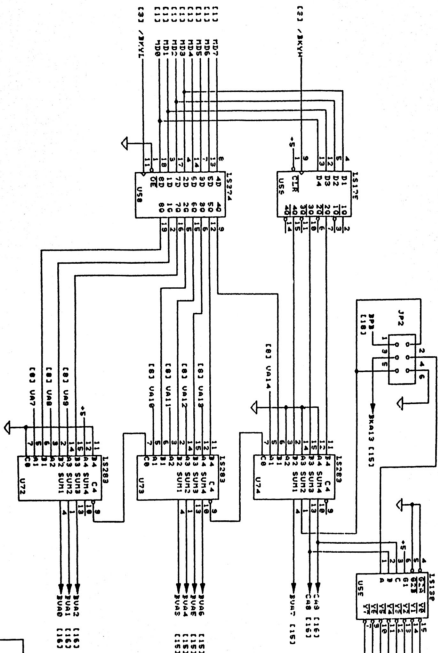

**THE LELAND CORPORATION**

TITLE \_\_\_\_\_  
 BACKGROUND VERTICAL ADDRESS \_\_\_\_\_  
 SIZE CODE NUMBER \_\_\_\_\_ REV \_\_\_\_\_  
 DATE 2-13-81 SHEET 1 OF 13

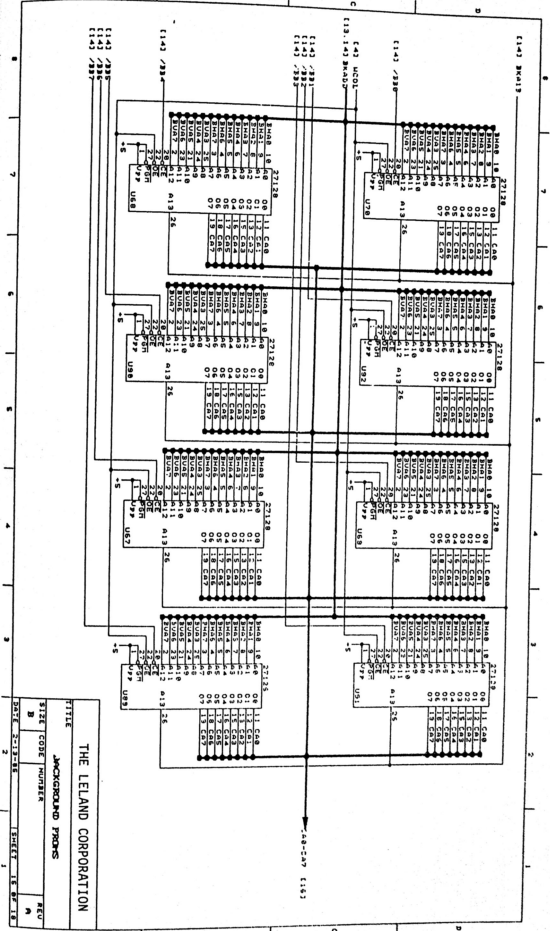

THE LELAND CORPORATION	
JACKGROUND PANS	
TITLE	REV
SIZE CODE NUMBER	A
DATE 2-13-88	SHEET 15 OF 18







NOTES:

# K7000 COLOR MONITOR SCHEMATIC DIAGRAM

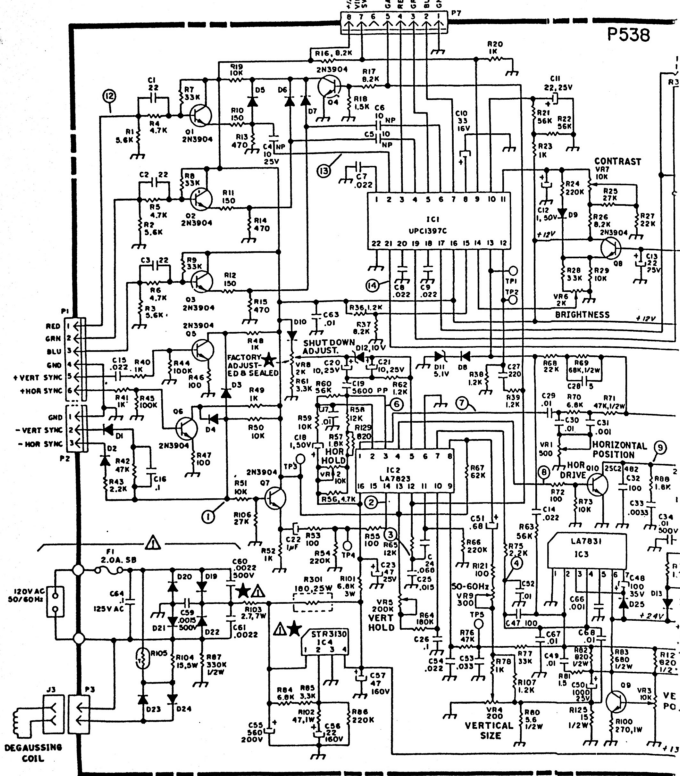

P538

NTRAST

HORIZONTAL POSITION

VERTICAL POSITION

P448 RED GRN BLU

CUT OFF DRIVE CUT OFF DRIVE CUT OFF DRIVE

CRT 22.5mm NECK

25K7107

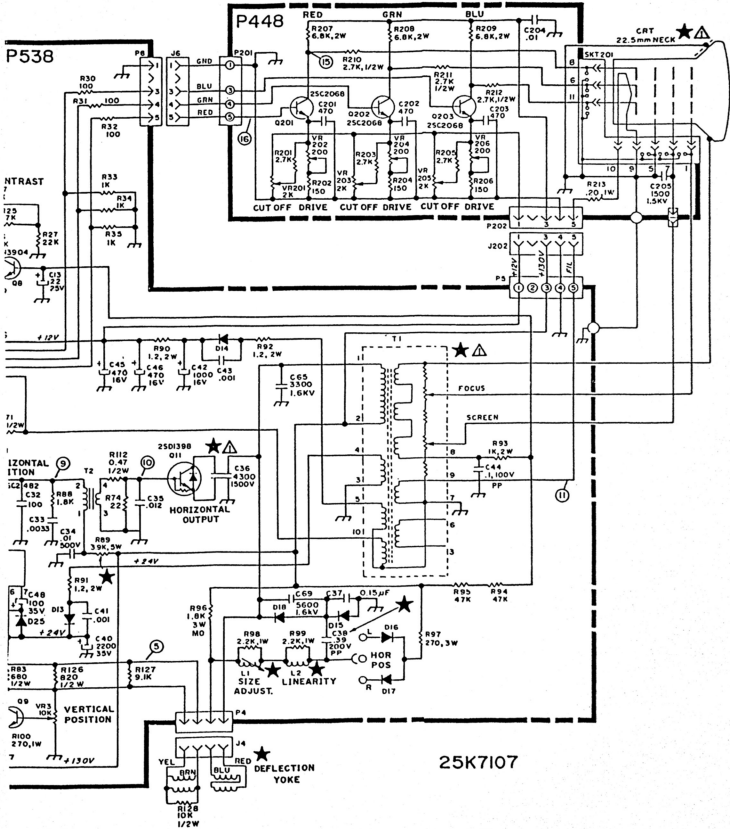



1841 Friendship Dr., El Cajon, CA 92020-9981  
619-562-7000 Telex - 4974293 Cintron Fax - 619-562-9468