

TM
JACK the
GIANTKILLER



C
CINEMATRONICS
INCORPORATED
COPYRIGHT 1982

OPERATION AND MAINTENANCE
MANUAL

CINEMATRONICS, INC.
1841 FRIENDSHIP DRIVE
EL CAJON, CA 92020
(714) 562-7000

TELEX: CINEMAT ELCJ 697891
CALL TOLL FREE: (800) 854-2666
IN CALIFORNIA CALL: (714) 562-7000
SALES: 8-5 (PST) WEEKDAYS
SERVICE: 8-5 (PST) WEEKDAYS

JACK THE GIANTKILLER

GAME MANUAL

TABLE OF CONTENTS

	<u>PAGE</u>
FCC WARNING	1
WARRANTY.	2
CUSTOMER SERVICE PROCEDURES	3
RECEIVING AND INSTALLING.	5
JACK THE GIANTKILLER - GAME DESCRIPTION	6
OPTION SWITCH SETTINGS.	10
ROUTINE MAINTENANCE AND SERVICE	11
WELLS-GARDNER COLOR MONITOR INFORMATION	12
PARTS LIST - COMPONENT P.C. BOARDS.	18
APPENDIX A - ASSEMBLY DRAWINGS AND SCHEMATICS	21
DATA POWER - POWER SUPPLY SCHEMATIC	22
UPPER P.C.B. COMPONENT LAYOUT DIAGRAM.	23
LOWER P.C.B. COMPONENT LAYOUT DIAGRAM.	24
GAME ELECTRONICS SCHEMATICS.	25-33

CINEMATRONICS, INC.

WARNING:

This equipment generates, uses, and can radiate radio frequency energy; and, if not installed and used in accordance with the Instruction's Manual, may cause interference to radio communication. As temporarily permitted by regulation, it has not been tested for compliance pursuant to Subpart J of Part 15 of FCC rules, which is designed to provide reasonable protection against such interference. Operation of this equipment in a residential area is likely to cause interference in which case the user at his own expense will be required to take whatever measures may be required to correct the interference.

WARRANTY

Cinematronics, Inc. warrants the goods to be free from defects in material and workmanship under normal use and service for a period of ninety (90) days from the date of shipment from factory. Cinematronics makes no representation or warranties concerning the goods whether express or implied by operation of law or otherwise, including those of merchantability or fitness for any particular purpose, or with respect of patent infringement, except as may be specifically made herein. Cinematronics limits its warranty obligations herein to the repair or replacement of such parts which have been returned to Cinematronics' plant at purchaser's expense and which examination shall disclose Cinematronics' satisfaction to have been so defective and to the shipment of such repaired or replacement parts to the purchaser F.O.B. the shipping point.

This warranty does not apply to any Cinematronics' product which has been altered or repaired by unauthorized personnel or service facilities or any products which have had the unit serial number altered or removed.

Upon acceptance of the goods, the purchaser agrees to assume all liability for damages and/or bodily injury by the purchaser or any other person and to hold Cinematronics, Inc. harmless from liability or claims arising from the use of the goods by any person. Purchaser further agrees to indemnify Cinematronics, Inc. from any liability, claim, cause of action or litigation resulting from the use or misuse of the goods by any person.

Parts returned for warranty service must be packaged so that no damage is incurred during the shipment. Full documentation and instructions must accompany returned parts. Parts must be shipped prepaid to:

Cinematronics, Inc.
1841 Friendship Drive
El Cajon, CA 92020

CUSTOMER SERVICE PROCEDURES
FOR AUTHORIZED CINEMATRONICS' DISTRIBUTORS

It is the desire of Cinematronics, Inc. to provide efficient and courteous service should the need arise. We have a fully staffed Customer Service Department and encourage you to call our toll-free number: (800) 854-2666 for technical assistance between the hours of 8:00 A.M. and 5:00 P.M., California time, Monday through Friday.

In order to provide the very best service possible, the following procedure for ordering or returning parts must be followed:

1. All equipment ordered from Customer Service, whether in or out of Warranty, must be placed with a Distributor's purchase order, either by mail or verbally by telephone.
2. Advance replacement items may be obtained only during the term of the Warranty and when such items are available, using the same procedure as when ordering parts. When ordering a PCB, please include with your order the game serial number and the number of the PCB you wish replaced.
3. All items received as advance replacements will, after a period of thirty (30) days, become the property of the Distributor, with applicable charges applied in the event Customer Service has not received the defective item against which the advance replacement was made.
4. The Distributor must call this facility for an RMA number prior to returning any item. Please be prepared to provide us with the game serial number and the PCB number when requesting an RMA.
5. In all situations covered above, and in all other situations, the Warranty offered by Cinematronics, Inc. is applicable and should be fully understood.
6. Parts returned for service must be packaged so that no damage is incurred during the shipment. Cartons without a prominently displayed RMA number will not be accepted. Full

documentation including game serial number, PCB number on outside of package, and reason for return must accompany parts. Ship prepared to:

Cinematronics, Inc.
Customer Service Department
1841 Friendship Drive
El Cajon, CA 92020

(800) 854-2666

(714) 562-7000

RECEIVING AND INSTALLING

RECEIVING INSPECTION

Your game was shipped in ready-to-play condition. However, after removal of the shipping carton, a brief visual examination is suggested.

Naturally, you will want to make note of any physical damage to the game cabinet and its external components for freight claim purposes. Considering the quality of the shipping carton, any damage to the exterior would indicate possible interior damage as well.

The interior of the game should also undergo a brief examination for: loose mounting hardware (check to be sure that the major components are still securely mounted); disconnected or loose wires, cables or harnesses; electronic devices loose in their sockets; etc.

At this time the game serial number should be logged. Remember that the game serial number will be required if you need service from your distributor. Please complete the postage-free reply card and mail immediately.

ELECTRICAL REQUIREMENTS

Unless specified otherwise, your game was shipped to operate at 115 VAC, 50/60 Hz.

A good earth ground is essential for the proper operation of this game or for that matter, any electronic device. Problems with instability and erratic operation of computer-type devices can usually be traced to an ineffective ground system. Therefore, plug the game into a properly wired three prong outlet. If a three prong to a two prong AC adaptor must be used, an alternate method of grounding the third prong must be used.

JACK THE GIANTKILLER

GAME PLAY

The game follows the story of Jack as he climbs the beanstalk to retrieve treasures from the giant's castle. The game has six different screens and twelve difficulty levels. The difficulty levels and the order of appearance of the screens are as follows:

<u>DIFFICULTY LEVEL</u>	<u>SCREENS</u>
1, 5, 9	1, 4, 5
2, 6, 10	1, 2, 4, 5
3, 7, 11	1, 2, 3, 4, 5
4, 8, 12	1, 2, 3, 4, 5, 6

SCREEN 1 - JACK CLIMBING THE BEANSTALK

In this screen, Jack begins his ascent to the giant's castle. Jack must climb the beanstalk without falling off. Along the way, he can gather beans, which later can be used for protection against attacking enemies. This is the only time during the game when he can gather beans. Jack can either jump over or throw beans at his enemies. He also has the ability to jump from branch to branch on the beanstalk. During this scene, Jack must avoid the woodpecker, caterpillar, moth and flying bee.

SCENE 2 - JACK IN THE CLOUDS

After climbing the beanstalk, Jack must walk through the cloud pattern. One false step will cause Jack to tumble down to earth. Jack must avoid the lions and attacking birds as he makes his way to the castle's drawbridge. Jack may jump over the lions and birds or hit them with beans to destroy them. Once he has walked through the clouds, Jack must wait until the drawbridge is lowered to allow him to cross and enter the castle.

SCENE 3 - JACK ON THE STAIRWAY LEADING TO THE GIANT'S ROOM

Upon entering the castle, Jack finds himself on the stairway leading to the giant's room. Jack must run up the stairway leaping over the missing stones. Jack must also dodge the steps falling from above. In addition, Jack can jump over or throw beans at the mouse and cat running down the stairway.

SCENE 4 - JACK IN THE GIANT'S ROOM

Once Jack reaches the top of the stairs safely, he finds himself in the giant's room. A series of platforms and stairs lead up to the giant's table, where the singing harp, a bag of gold, the goose that lays the golden eggs, the princess and the sleeping giant are seen. Jack must jump from platform to platform and climb the stairs to reach the table. Flying magic lamps will attack Jack. Jack can either throw beans at the lamps or try to avoid them. The goose will move across the table laying golden eggs. If Jack can catch these eggs in the basket he is carrying, he scores extra points. Once Jack reaches the table, Jack must run to the object flashing (the harp, bag of gold, goose and then the princess) and rescue it.

SCENE 5 - JACK CLIMBING DOWN THE BEANSTALK

After rescuing the designated object, Jack must climb back down the beanstalk carrying the object under his arm and reach his cottage. In climbing down the beanstalk, Jack faces the same enemies he did while climbing the beanstalk. When Jack is climbing down the beanstalk with the princess, the giant will awake and begin to chase Jack down the beanstalk.

SCENE 6 - JACK CHOPPING DOWN THE BEANSTALK

Once Jack reaches the ground with the princess, he must fetch the axe lying near the beanstalk and begin chopping down the beanstalk. Jack must chop down the beanstalk before the giant reaches him.

When Jack successfully returns to his cottage with an object, a cartoon will appear. The objects to retrieve in order are the harp, the bag of gold, the goose and the princess. Once all of those objects have been retrieved, the scenes repeat themselves, only at a harder difficulty level.

DIFFICULTY LEVELS

All the adversaries that can appear in a screen will not be present for every difficulty level. The following table outlines the objects Jack will face in each screen and difficulty level. A dash indicates that a particular screen does not appear for the difficulty level.

DIFFICULTY LEVELS

<u>SCREEN</u>	<u>LEVELS:</u>	<u>1,5,9</u>	<u>2,6,10</u>	<u>3,7,11</u>	<u>4,8,12</u>
1		Caterpillar	Moth Caterpillar	Woodpecker Moth Caterpillar	Bee Woodpecker Moth Caterpillar
2		-	None	Lions	Birds Lions
3		-	-	Mouse	Falling Stairs Cat Mouse
4		None	None	None	Magic Lamps
5		Rocks Thrown by Giant	Rocks Thrown by Giant	Rocks Thrown by Giant	Bee Rocks Thrown by Giant
6		-	-	-	None

If a player is in a particular screen for more than a pre-determined amount of time, all possible adversaries will appear.

SCORING

- 50 Points for every bean picked
- 100 Points for hitting a woodpecker with a bean
- 100 Points for hitting a caterpillar with a bean
- 150 Points for hitting a moth with a bean
- 300 Points for hitting a bee with a bean
- 200 Points for hitting a bird with a bean
- 100 Points for hitting a lion with a bean
- 300 Points for hitting a cat with a bean
- 200 Points for hitting a mouse with a bean
- 500 Points for hitting a lamp with a bean
- 100 Points for catching a gold egg in the basket

Every time a screen is successfully completed, bonus points are awarded. The bonus points for each screen by difficulty level are shown in the table below. A dash indicates the screen does not appear in the difficulty level.

DIFFICULTY LEVELS

<u>SCREEN</u>	<u>1,5,9</u>	<u>2,6,10</u>	<u>3,4,11</u>	<u>4,8,12</u>
1	500	1000	1500	2000
2	-	1500	2000	2500
3	-	-	2500	3000
4	1000	2000	3000	3500
5	1500	2500	3500	4000
6	-	-	-	None

GAME FEATURES

1. Eight coinage settings.
2. Either three or five "Jacks" per game.
3. Extra "Jack" every 10,000 points or one "Jack" at 10,000 points.
4. Easy/hard difficulty switch, starts game at level one or level five.
5. Free play switch for demonstrations.
6. Six different screens.
7. Twelve difficulty levels.
8. Cartoons shown after each successful return to Jack's cottage.
9. Complete hardware diagnostics accessed by dip switch.

OPTION SWITCH SETTINGS

Early model boards do not have Dip Switches identified on board. Their location is as shown at right. Later model boards have switches labeled "SW1" and "SW2" next to the Dip Switches themselves. Note that the locations of switches 1 and 2 are not identical on early and late model boards.

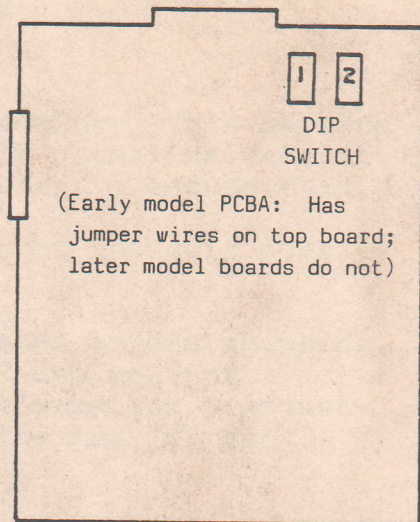

DIP SWITCH NO. 1

OPTION	FACTORY SETTING	DESCRIPTION	1	2	3	4	5	6	7	8
COIN OPERATE (CHUTE 1)	X	1 Coin 1 Play 1 Coin 2 Play 1 Coin 3 Play 1 Coin 5 Play	OFF ON	OFF OFF ON ON						
COIN OPERATE (CHUTE 2)	X	1 Coin 1 Play 2 Coin 1 Play 3 Coin 1 Play 4 Coin 1 Play			OFF ON	OFF OFF ON ON				
NUMBER OF JACKS	X	3 5					OFF ON			
EXTRA JACKS	X	EVERY 10,000 POINTS EVERY JACK ONLY						OFF ON		
DIFFICULTY	X	EASY 1 DIFFICULT 5							OFF ON	
NUMBER OF BEANS	X	TIMES 1 TIMES 2								OFF ON

DIP SWITCH NO. 2

OPTION	FACTORY SETTING	DESCRIPTION	1	2	3	4	5	6	7	8
CABINET TYPE	X	TABLE UPRIGHT	OFF ON							
SYSTEM CHECK	X	NORMAL DIAGNOSTIC						OFF ON		
PCB CHECK	X	NORMAL SUSTAIN JACK							OFF ON	
	X	NORMAL FREE PLAY								OFF ON

ROUTINE MAINTENANCE & SERVICE

Because of the solid state electronic circuitry, this machine should require very little maintenance and only occasional adjustments. However, it is necessary to take measures to ensure this.

The volume control is located on the rear of the coin door and can be accessed by opening the coin door.

The video monitor has been properly adjusted before shipping. Occasionally minor adjustments are necessary. See monitor specifications and schematics for technical information. Adjustment controls for the monitor are located at the rear of the monitor.

This machine should be serviced only by a qualified technician.

Do not make any adjustments on this machine while the power is on.

For service information, contact:

CINEMATRONICS, INC.
1841 FRIENDSHIP DRIVE
EL CAJON, CA 92020
(714) 562-7000

POWER SUPPLY

The computer board in this game operates most efficiently and reliably when the power supply is set so that the voltage on the board is 5.0 volts, ± 0.1 volts. To check this, place a meter across 5 volts and ground at the edge connector. If necessary, adjust the screwdriver control on the power supply so the meter reads between 4.9 and 5.1 volts.

WARNINGS

1. Power Up Warning—

An isolation transformer must be used between the AC supply and the AC plug of the monitor before servicing or testing is performed since the chassis and the heat sink are directly connected to one side of the AC line which could present a shock hazard.

Before servicing is performed, read all the precautions labelled on the CRT and chassis.

2. **X-RAY RADIATION WARNING NOTICE**

WARNING: PARTS WHICH INFLUENCE X-RAY RADIATION IN HORIZONTAL DEFLECTION, HIGH VOLTAGE CIRCUITS AND PICTURE TUBE ETC. ARE INDICATED BY (★) IN THE PARTS LIST FOR REPLACEMENT PURPOSES. USE ONLY THE TYPE SHOWN IN THE PARTS LIST.

3. High Voltage—

This monitor contains HIGH VOLTAGES derived from power supplies capable of delivering LETHAL quantities of energy. Do not attempt to service until all precautions necessary for working on HIGH VOLTAGE equipment have been observed.

4. CRT Handling—

Care must be taken not to bump or scratch the picture tube as this may cause the picture tube to implode resulting in personal injury. Shatter proof goggles must be worn when handling the CRT. High voltage must be completely discharged before handling. Do not handle the CRT by the neck.

5. **PRODUCT SAFETY NOTICE**

WARNING: FOR CONTINUED SAFETY REPLACE SAFETY CRITICAL COMPONENTS ONLY WITH MANUFACTURER RECOMMENDED PARTS. THESE PARTS ARE IDENTIFIED BY SHADING AND BY (Δ) ON THE SCHEMATIC DIAGRAM.

AVERTISSEMENT: POUR MAINTENIR LE DEGRE DE SECURITE DE L'APPAREIL NE REMPLACER LES COMPOSANTS DONT LE FONCTIONNEMENT EST CRITIQUE POUR LA SECURITE QUE PAR DES PIECES RECOMMANDEES PAR LE FABRICANT.

For replacement purposes, use the same type or specified type of wire and cable, assuring the positioning of the wires is followed (especially for H.V. and power supply circuits). Use of alternative wiring or positioning could result in damage to the monitor or in a shock or fire hazard.

PERFORMANCE AND OPERATING DATA

1. Apply a suitable power source to the monitor through an isolation transformer.
2. Apply a suitable signal source to the monitor PCB by means of P205.
3. Set Up Controls.

All controls are preset at the factory, but may be adjusted to suit program material.

1.0 Supply

Voltage	108 VAC-132 VAC
Frequency	50 Hz-60 Hz

Note: Apply supply voltage through an isolation transformer with 1 Amp. minimum capability.

2.0 High Voltage (EHT)

For 19"V models 25.5 ± 0.8 K.V. at 0 Beam

Note: Condition for above 1 (beam) = 0
A.C. = 120V

3.0 Service Set-Up Controls

POWER PC BOARD

- 3.1 Voltage Adjustment, VR501 (Set for 127V DC)

VERT/HORIZ PC BOARD

- 3.2 Vertical Hold Control, VR301
- 3.3 Vertical Size Control, VR302
- 3.4 Horizontal Oscillator Coil, L351
- 3.5 Horizontal Hold Control, VR351

MAIN PC BOARD

- 3.6 Vertical Raster Position Adjustment, J604 (3 positions)
- 3.7 Horizontal Raster Position Adjustment, J608 (3 positions)

INTERFACE PC BOARD

- 3.8 Black Level Control, VR201
- 3.9 Horizontal Video Position Control, VR202

NECK PC BOARD

- 3.10 Video Drive Controls, Red VR401
Green VR402
- 3.11 CRT Cut Off Controls, Red VR403
Green VR404
Blue VR405
- 3.12 Screen Control, VR406

CHASSIS

- 3.13 Focus Control, VR702
- 3.14 Horizontal Width Coil, L702

SERVICE INSTRUCTIONS

NOTE: All monitors are equipped with automatic degaussing coils (L701) which demagnetize the picture tube every time the monitor is turned on after being off for a minimum of 5 minutes. Should any part of the chassis become magnetized it will be necessary to degauss the affected area with a manual degaussing coil. Move the coil slowly around the CRT face area then slowly withdraw for a distance of 6 feet before turning off.

1.0 +127V ADJUSTMENT (See Fig. 1)

The +127V adj. control (VR501) is adjusted at the factory. However, if readjustment should be required, proceed as follows.

- 1.1 Operate monitor for at least 15 minutes at 120V AC line.
- 1.2 Connect Positive lead of V.T.V.M. to blue lead of TR502 negative lead to chassis ground.
- 1.3 Adjust VR501 to obtain +127V reading.
- 1.4 After adjustment VR501 must be locked with a sealing varnish.

2.0 BLACK LEVEL CONTROL ADJUSTMENT

This control has been set at the factory and should not need further attention, however, when the game is connected a slight adjustment of VR201 may be necessary to obtain the proper black level (the black portion of the picture just extinguished).

3.0 VERTICAL SIZE (HEIGHT)

The vertical height control is a screw-driver adjustment. Location of this control is shown in Fig. 2. This control must be adjusted slowly, if necessary, until the picture or test pattern attains the correct vertical proportions.

4.0 CIRCUIT PROTECTION

A 3.0A pigtail fuse, mounted on the Main Board has been provided to protect the Power Output Circuit.

5.0 FOCUS

Adjust the Focus control (VR702), located on the HV unit (T701), for maximum over-all definition and fine picture detail.

6.0 HORIZONTAL OSC. ALIGNMENT (See Fig. 2)

A warm-up period of at least five minutes should be allowed before alignment is carried out. With the monitor being driven from the game signal, set VR351 to its mechanical center and short the lower end of R328 (TP32) to ground. Adjust L351 until picture stops sliding horizontally. Remove the short.

7.0 HORIZONTAL VIDEO POSITION

If the video is off center on the raster some compensation can be made by adjusting this control.

8.0 VERTICAL RASTER POSITION ADJUSTMENT

If the video is off center vertically, (short dimension of picture tube) some compensation can be made by moving J604 to either No. 1 or No. 3 of P604. Position No. 1 moves raster up and position No. 3 moves raster down.

9.0 HORIZONTAL RASTER POSITION ADJUSTMENT

If the video is off center horizontally (long dimension of picture tube) some compensation can be made by moving J608 to either No. 1 or No. 3 of P608. Position No. 1 moves raster to the left and position No. 3 moves raster to the right.

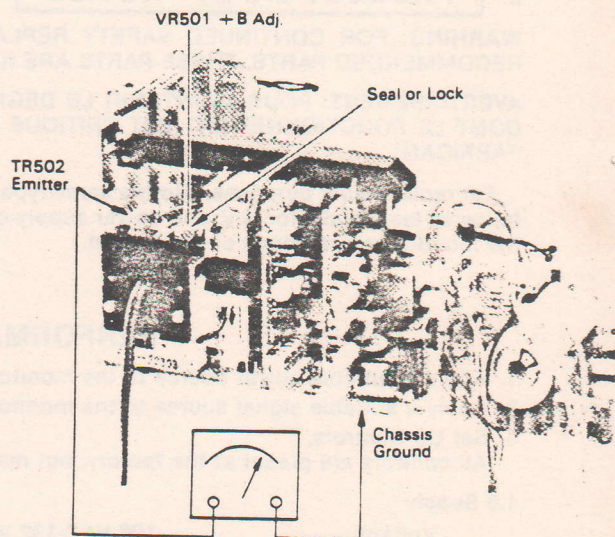

FIGURE 1

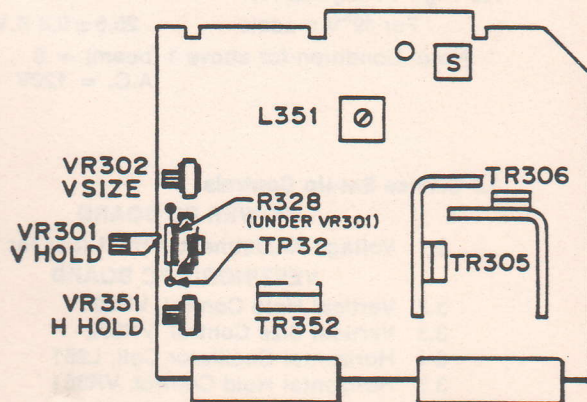

FIGURE 2
VERT./HORIZ. BOARD

P.C. BOARD LAYOUT

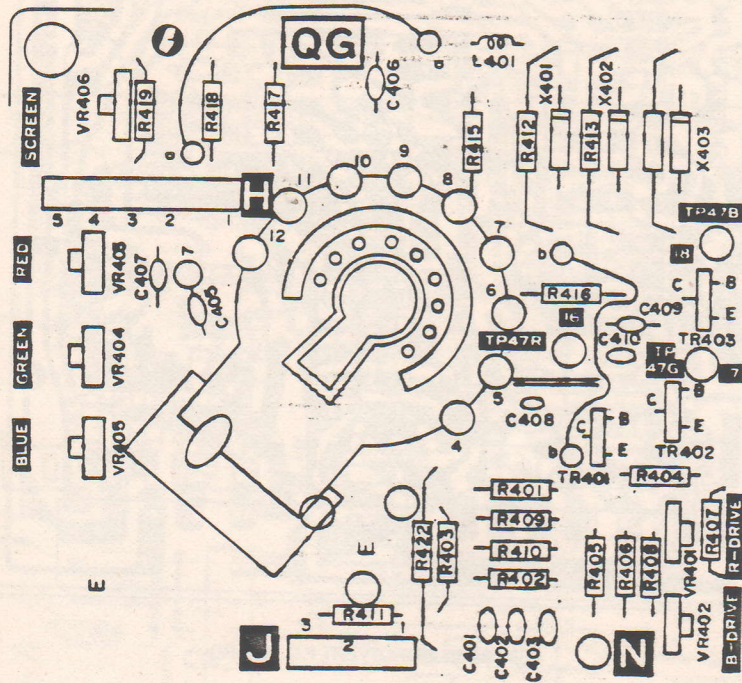

FIGURE 13. NECK P.C. BOARD

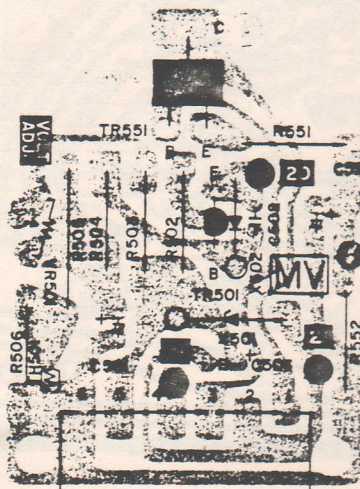

FIGURE 14. POWER P.C. BOARD

P.C. BOARD LAYOUT

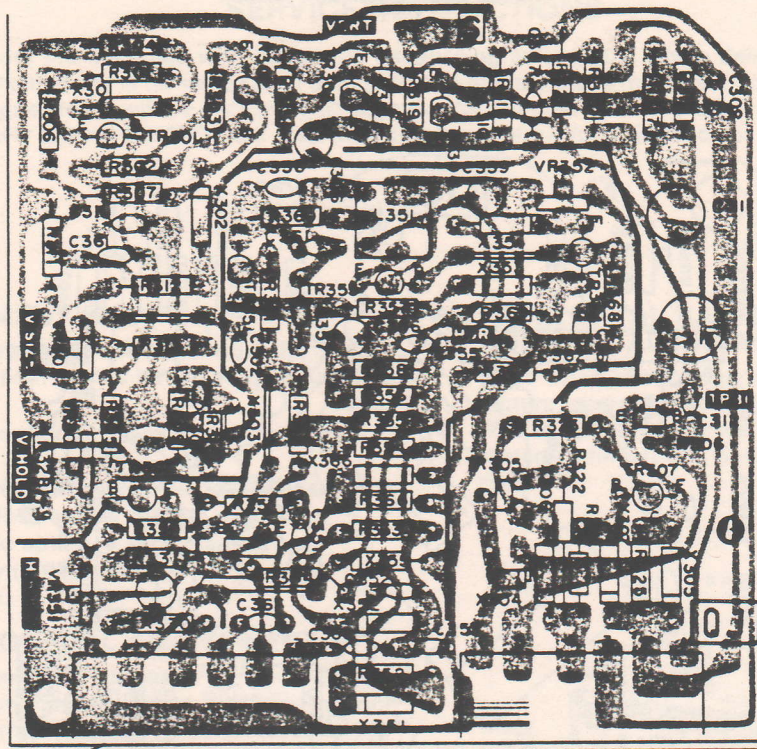

FIGURE 15. HORIZ/VERT P.C. BOARD

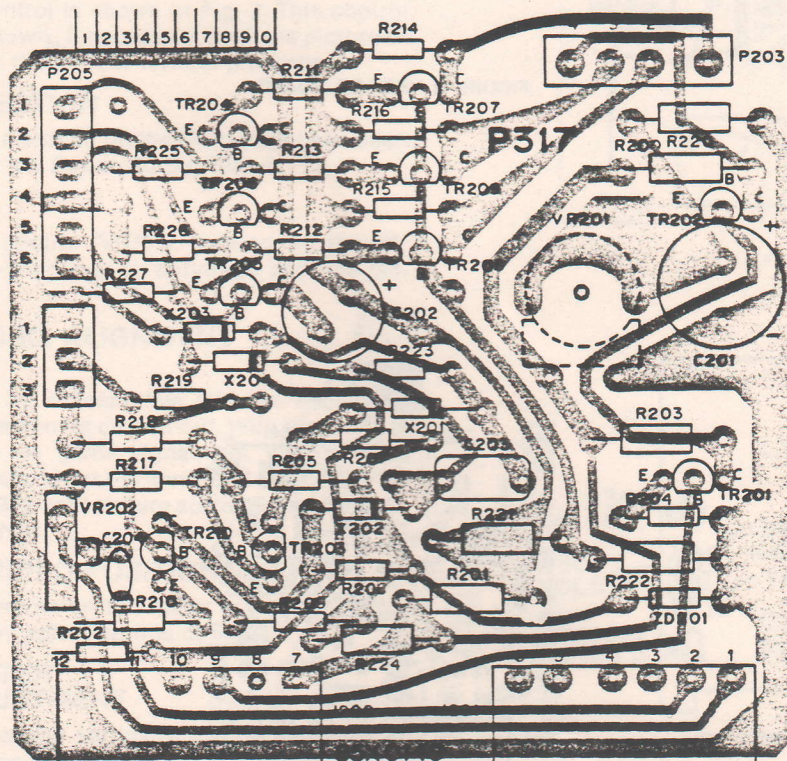

FIGURE 16. INTERFACE BOARD (P317 AND P318)

P.C. BOARD LAYOUT

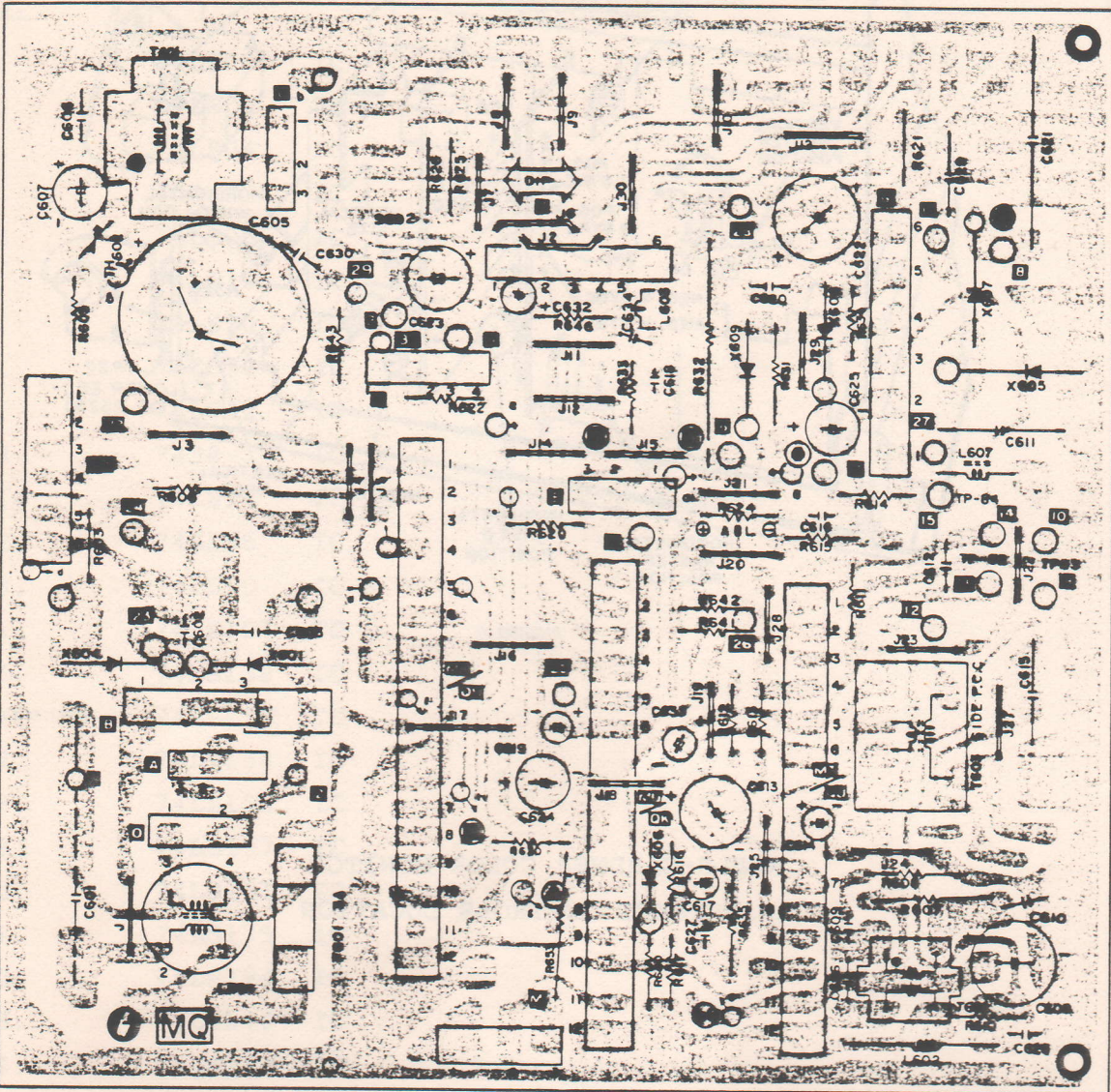

FIGURE 12. MAIN P.C. BOARD

REAR CHASSIS CONTROLS

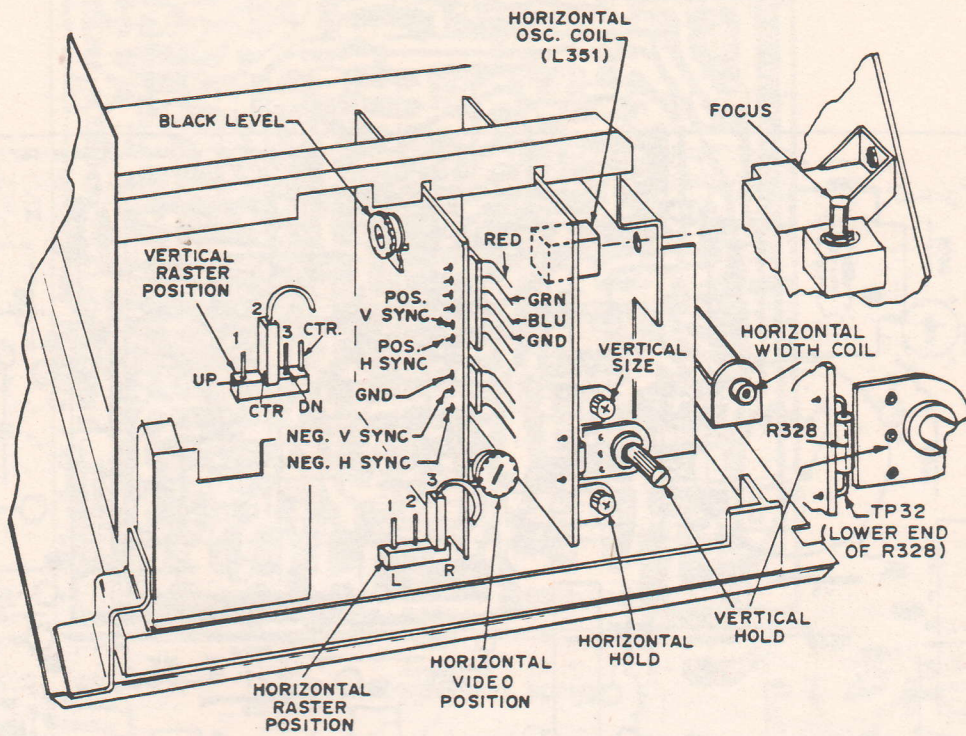

FIGURE 17

11-81

WGEC SERIES K4600 69X1090-100

WELLS-GARDNER COLOR MONITOR
ADJUSTMENT CONTROLS LOCATION

JACK THE GIANTKILLER

PARTS LIST

<u>NO.</u>	<u>DESCRIPTION</u>		<u>USAGE</u>
1.	74LS00	IC	4
2.	74LS02	IC	3
3.	74LS04	IC	5
4.	7404	IC	2
5.	74LS08	IC	3
6.	74LS10	IC	1
7.	74LS20	IC	2
8.	74LS30	IC	1
9.	74LS32	IC	5
10.	7438	IC	1
11.	74LS74	IC	8
12.	74LS86	IC	6
13.	74LS90	IC	1
14.	74LS107	IC	1
15.	74LS138	IC	2
16.	74LS139	IC	2
17.	74LS154	IC	1
18.	74LS155	IC	1
19.	74LS157	IC	16
20.	74LS161	IC	6
21.	74LS175	IC	1
22.	74LS194	IC	4
23.	74LS240	IC	6
24.	74LS244	IC	4
25.	74LS245	IC	8
26.	74LS273	IC	3
27.	74LS283	IC	2
28.	74LS378	IC	5
29.	74LS393	IC	3
30.	Z80A	CPU (CPU Section)	1
31.	Z80	CPU (Sound Section)	1

<u>NO.</u>		<u>DESCRIPTION</u>	<u>USAGE</u>
32.	2732	ROM IC	10
33.	M58725P	RAM IC	4
34.	2114-2	RAM IC	14
35.	82516	RAM IC	5
36.	74S189	RAM IC	4
37.	AY-3-8910	IC (LSI)	1
38.	Upd 1510	IC (Custom LSI)	1
39.	741	(Linear IC)	1
40.	MB 3713	(Linear IC)	1
41.	MC 14066	(CMOS IC)	2
42.	2732	E PROM	2
43.	2SC945	Transistor	1
44.	1S1588	Diode	2
45.	18.000	MHz Crystal	1
46.	0.22uf 35v	Tantalum Capacitor	4
47.	22uf 16v	Electrolytic Capacitor	1
48.	47uf 16v	Electrolytic Capacitor	1
49.	100uf 16v	Electrolytic Capacitor	4
50.	100uf 25v	Electrolytic Capacitor	2
51.	470uf 16v	Electrolytic Capacitor	1
52.	100pf 50v	Ceramic Capacitor	1
53.	0.01uf 25v	Ceramic Capacitor	1
54.	0.047uf 25v	Ceramic Capacitor	3
55.	0.1uf 12v	Ceramic Capacitor	70
56.	100 ohm $\frac{1}{4}$ watt	Resistor	1
57.	220 ohm $\frac{1}{4}$ watt	Resistor	5
58.	330 ohm $\frac{1}{4}$ watt	Resistor	4
59.	470 ohm $\frac{1}{4}$ watt	Resistor	7
60.	1K ohm $\frac{1}{4}$ watt	Resistor	12
61.	4.7K ohm $\frac{1}{4}$ watt	Resistor	5

<u>NO.</u>		<u>DESCRIPTION</u>	<u>USAGE</u>
62.	5.6K ohm $\frac{1}{4}$ watt	Resistor	1
63.	10K ohm $\frac{1}{4}$ watt	Resistor	1
64.	220 ohm $\frac{1}{4}$ watt	Upright Resistor	24
65.	220 ohm	Potentiometer	1
66.	1028	DIP Resistor Pak	4
67.	4728	DIP Resistor Pak	2
68.	1038	DIP Resistor Pak	2
69.		DIP Switch, 8 Position	2
70.		40 Pin IC Socket	1
71		24 Pin IC Socket	18
72.		18 Pin IC Socket	1
73.		60 Pin Male Connector	1
74.		60 Pin Female Connector	2
75.		Printed Circuit Board #1	1
76.		Printed Circuit Board #2	1

APPENDIX A

Assembly Drawings
Schematics
and
Wiring Diagrams

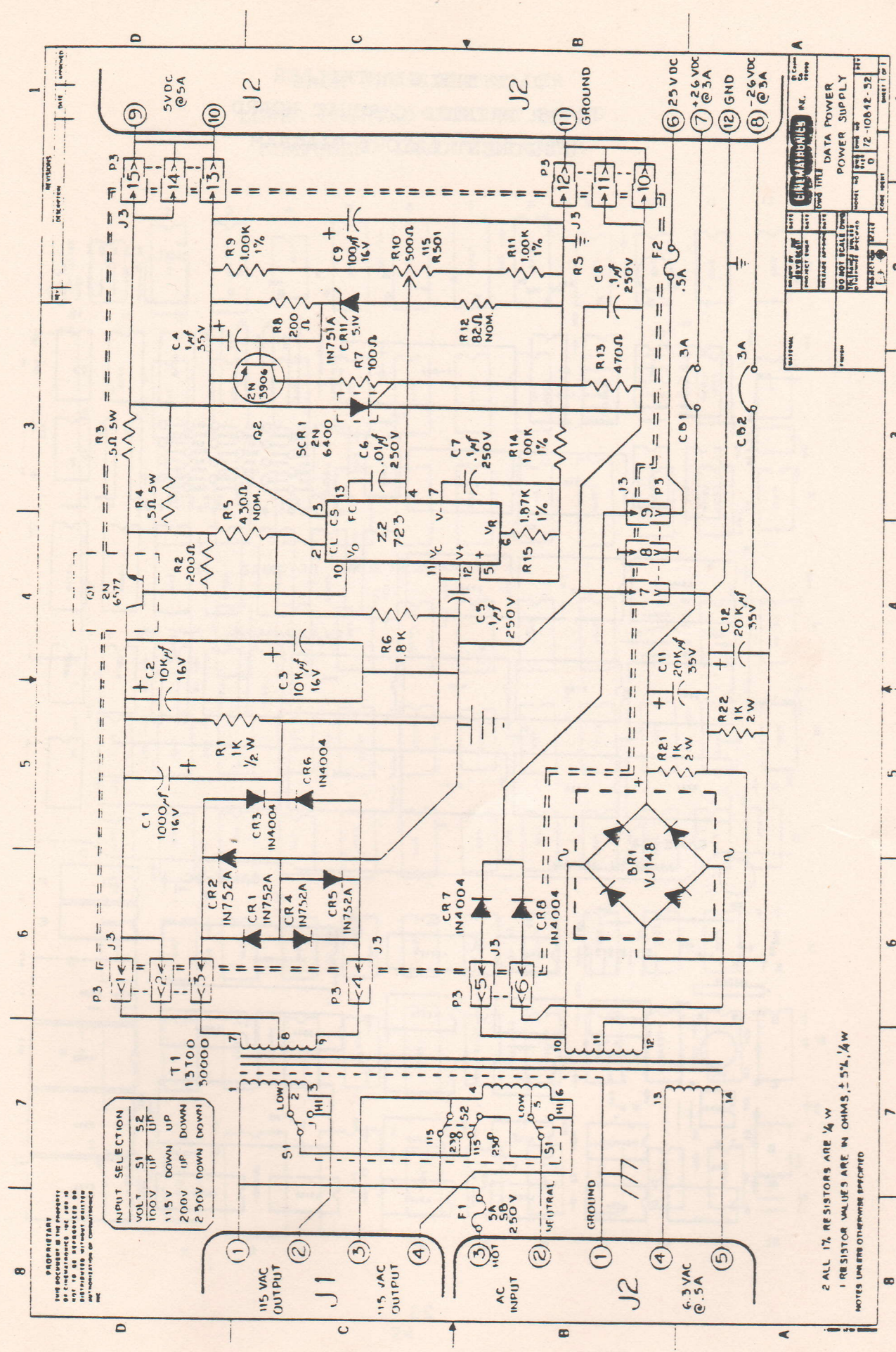

PROPRIETARY
 THE DESIGN OF THE PROPERTY OF
 CINCINNATI ELECTRONICS, INC.
 NO PART OF THIS DOCUMENT IS TO BE REPRODUCED OR
 DISTRIBUTED WITHOUT WRITTEN
 AND AUTHORITY OF CINCINNATI ELECTRONICS, INC.

INPUT SELECTION	
VOLT	51 52
100V	UP UP
115V	DOWN UP
200V	UP DOWN
250V	DOWN DOWN

CINCINNATI ELECTRONICS	
DATE	REV.
DESIGNED BY	DATE
CHECKED BY	DATE
RELEASED BY	DATE
NO. OF COPIES	DATE
ISSUED BY	DATE
REVISIONS	DATE
BY	DATE
APPROVED BY	DATE
PROJECT NO.	72-10842-32
FORM NO.	0
DATE	10/1/67
BY	
APPROVED BY	

2 ALL 1% RESISTORS ARE 1/4 W
 1 RESISTOR VALUES ARE IN OHMS, ±5%, 1/4 W
 NOTES UNLESS OTHERWISE SPECIFIED

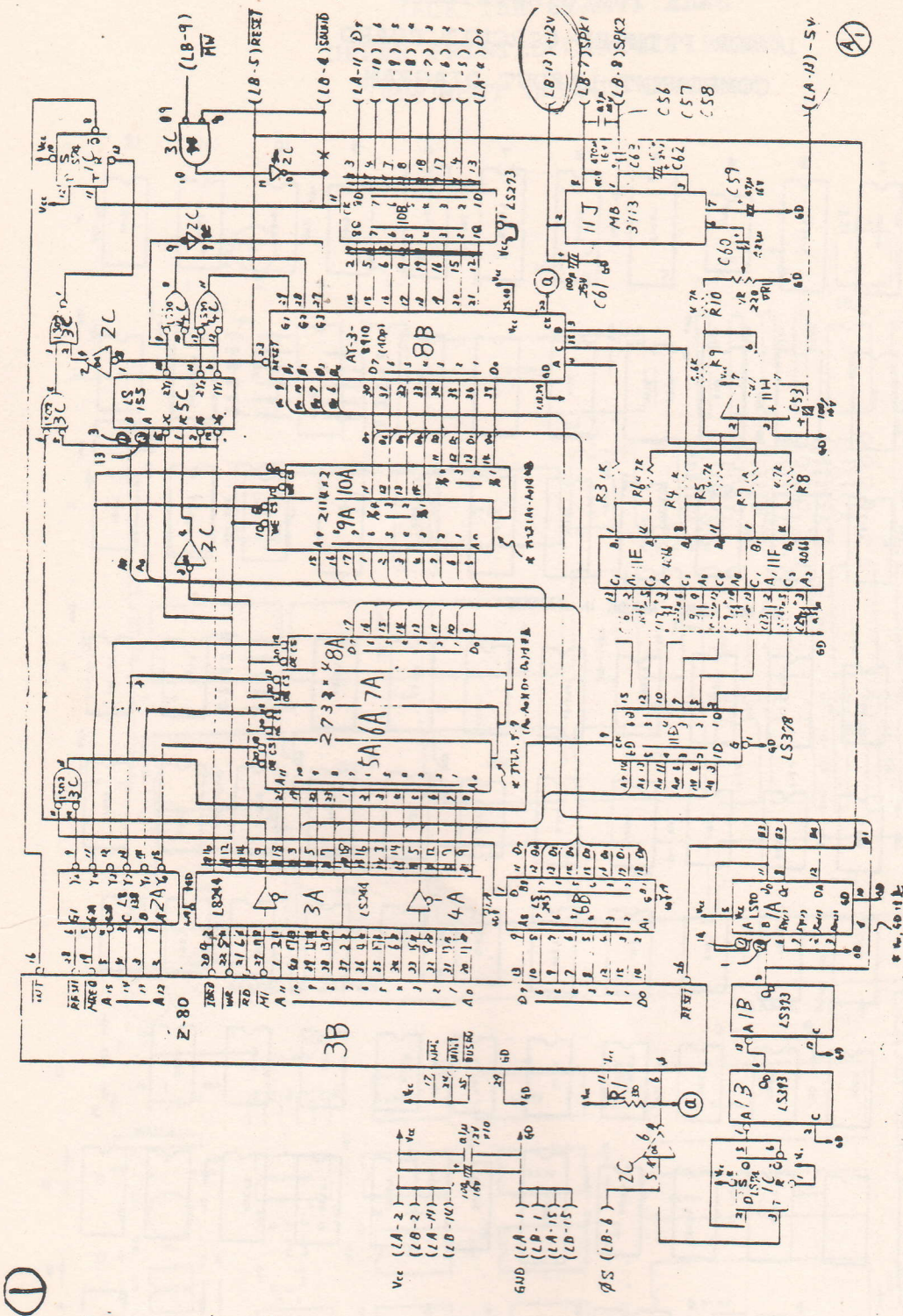

CIRCUIT BOARD SCHEMATIC

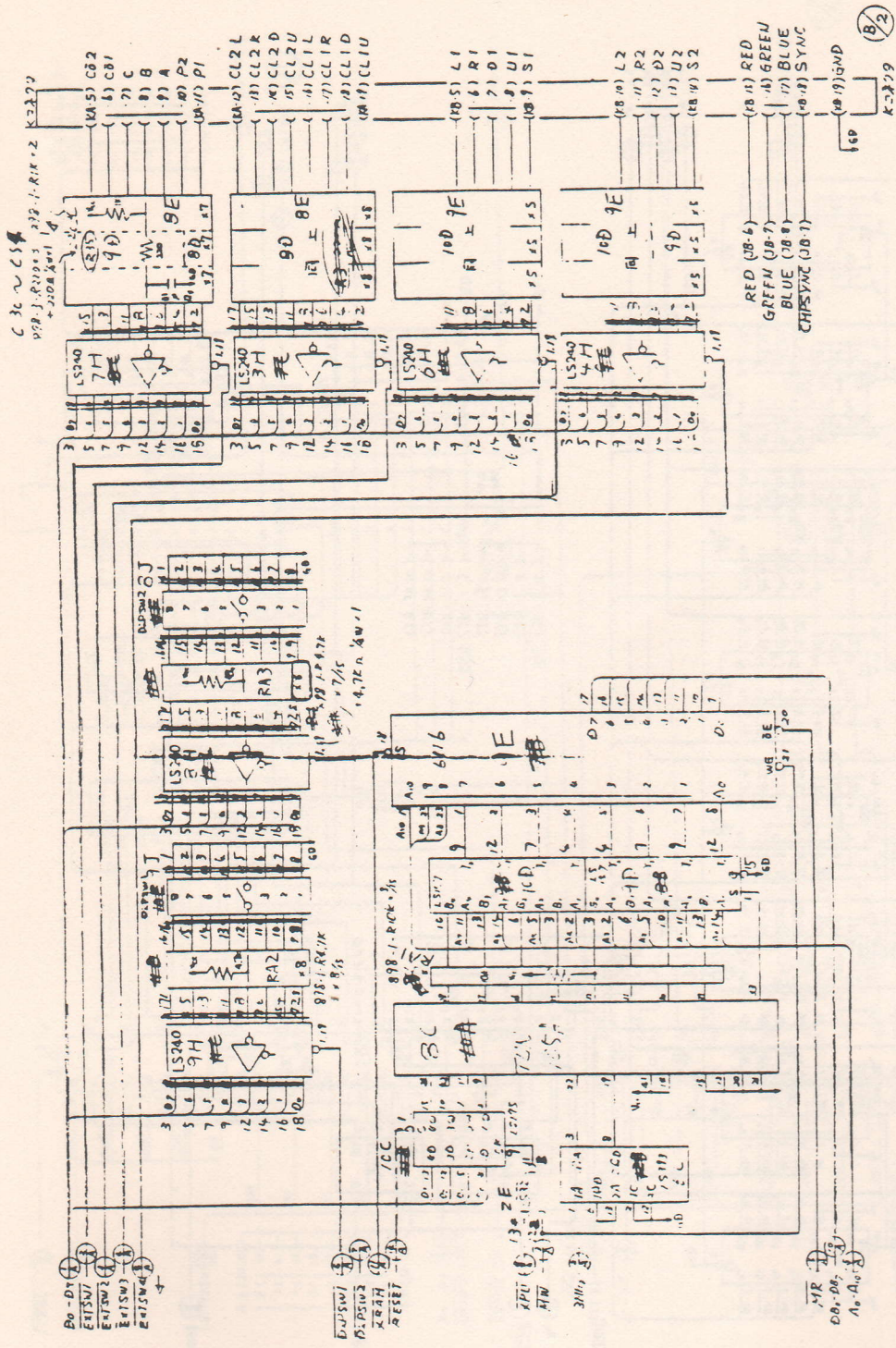

CIRCUIT BOARD SCHEMATIC

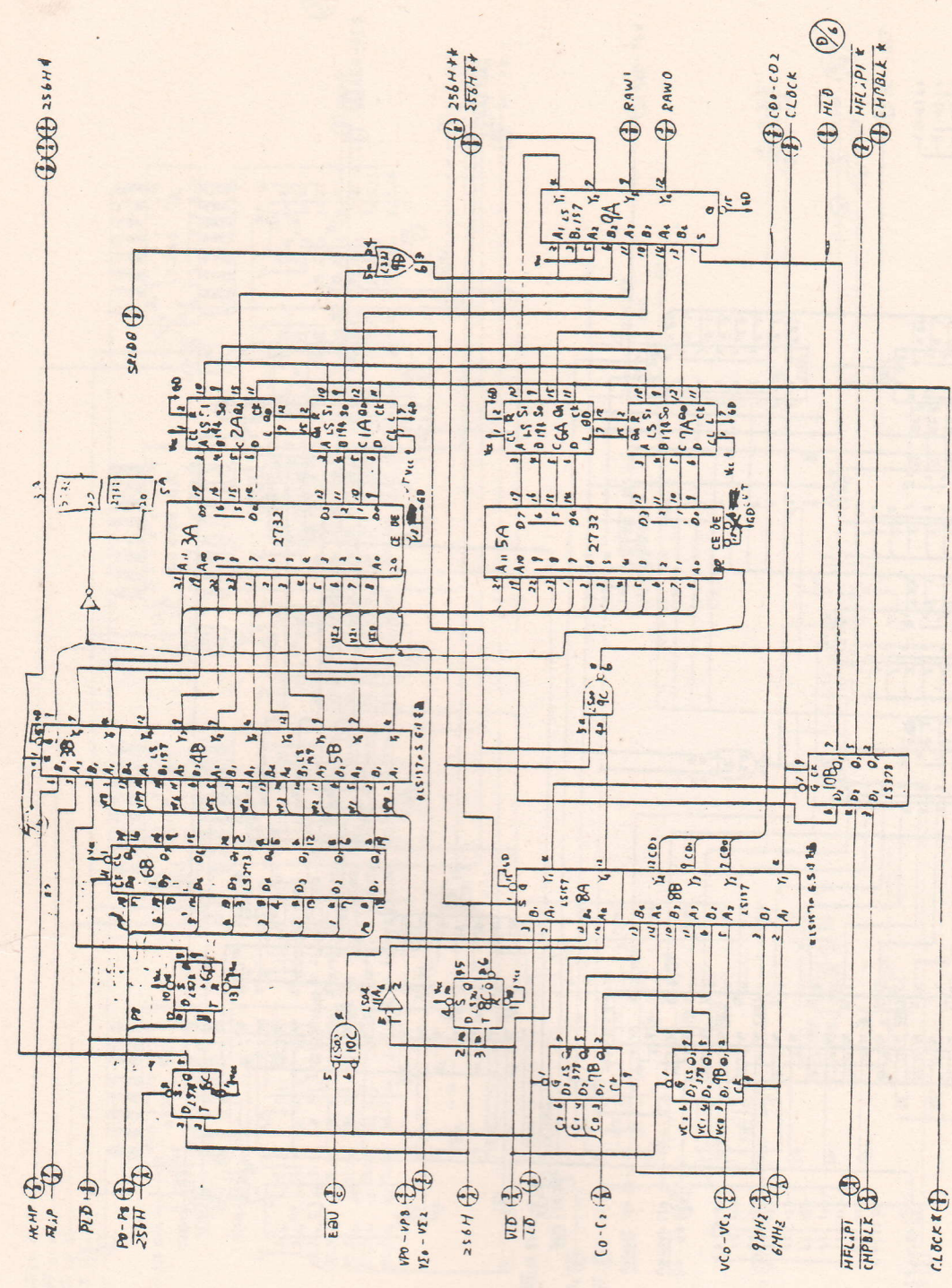

CIRCUIT BOARD SCHEMATIC

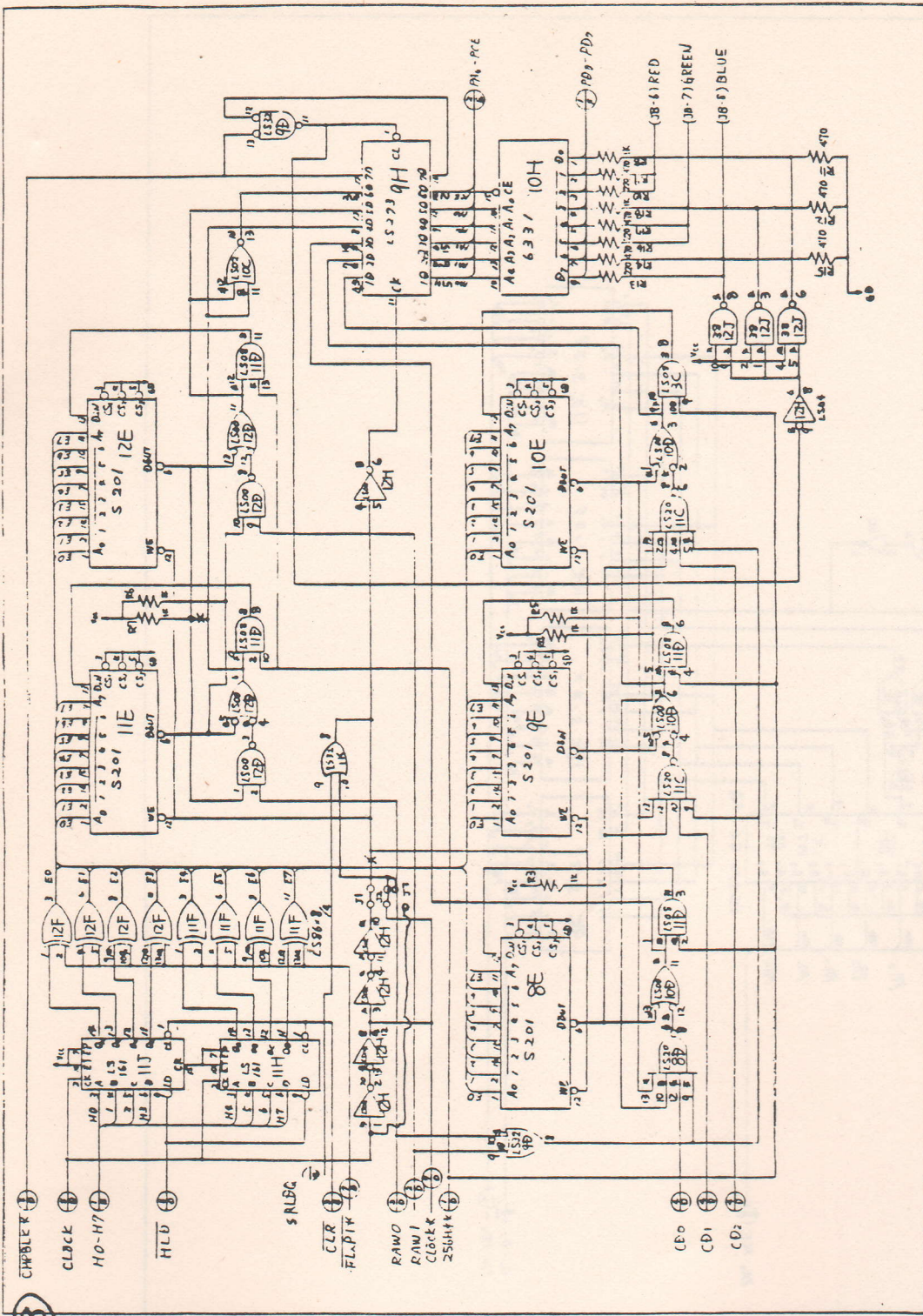

CIRCUIT BOARD SCHEMATIC

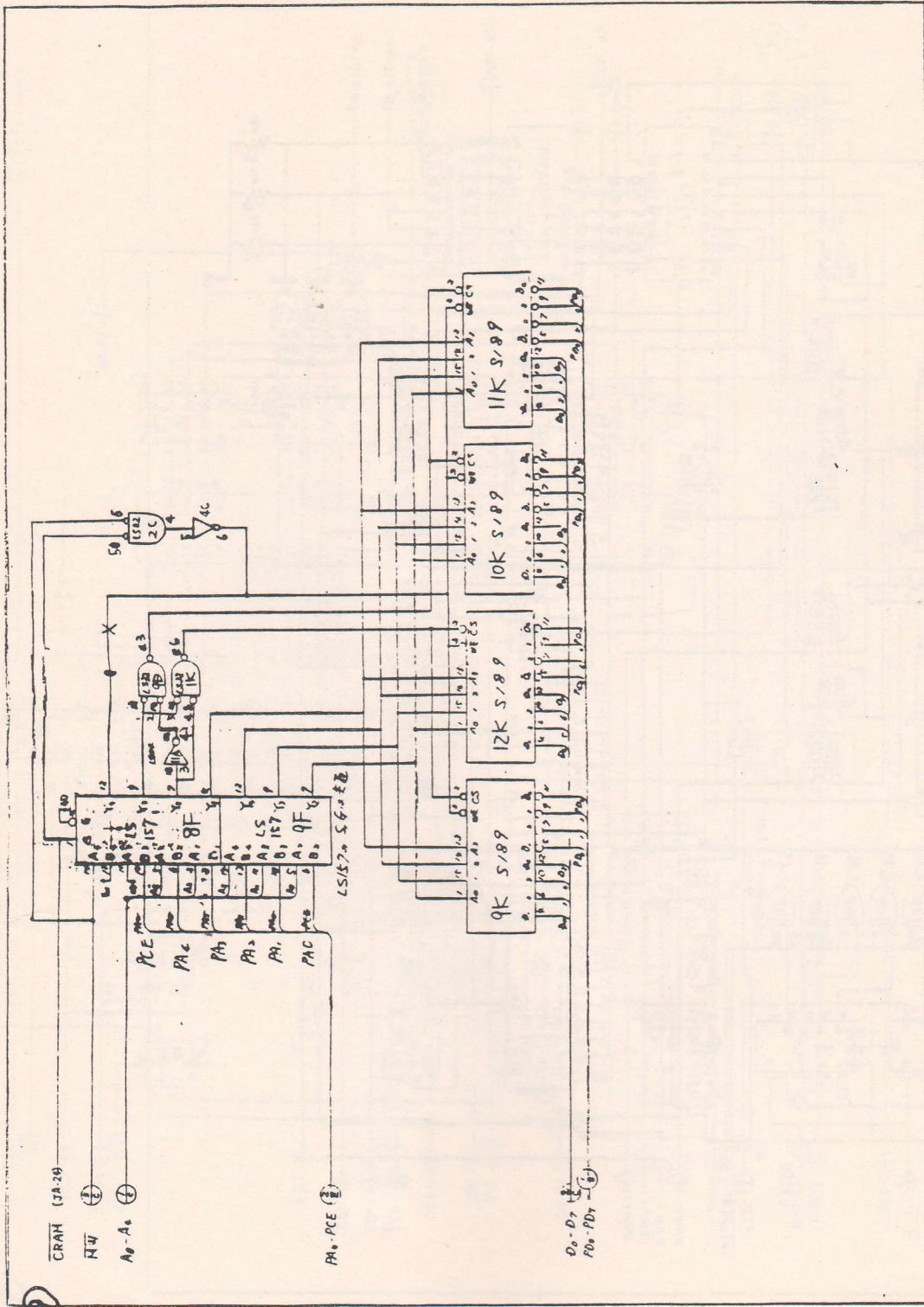

CIRCUIT BOARD SCHEMATIC

