

NOVEMBER 1994

16-40047-101

# ***KILLER INSTINCT***

**OPERATIONS MANUAL**

**- includes -**

**operation**

**parts information**

**wiring diagrams**



# ***KILLER INSTINCT***

MIDWAY Manufacturing Company reserves the rights to make modifications and improvements to its products. The specifications and parts identified in this manual are subject to change without notice.

## **TABLE OF CONTENTS**

### **Section 1 Operation and Troubleshooting**

<b>Safety</b> .....	1-2
<b>Setup Procedure</b> .....	1-3
Installation & Inspection.....	1-3
Location Requirements.....	1-3
Cabinet Assembly Diagram.....	1-4
<b>Servicing</b> .....	1-6
<b>Game Features</b> .....	1-8
Starting-up.....	1-8
Player Controls.....	1-8
Control Panel Diagram.....	1-8
<b>Game Operations</b> .....	1-9
Control Switches.....	1-9
Control Switch Location Diagram.....	1-9
<b>Menu System Operation</b> .....	1-10
Operation.....	1-10
Main Menu.....	1-10
Diagnostic Tests.....	1-11
Switch Test.....	1-11
DIP Switch Test & Table.....	1-12
CPU Board Test.....	1-13
Sound Board Test.....	1-13
Monitor Patterns Test.....	1-14
Check Disk.....	1-15
Burn-in Test.....	1-15
Coin Bookkeeping.....	1-16
Game Audits.....	1-17
Game Adjustments.....	1-22
Standard Pricing.....	1-24
Custom Pricing.....	1-25
Utilities.....	1-26
Volume Adjust.....	1-27
<b>Troubleshooting</b> .....	1-28

### **Section 2 Parts Information**

Cabinet Hardware, Electronic Rack, Monitor & Manuals .....	2-2
Control Panel, Fluorescent Lamp Assembly, Speaker, Transformer Assembly & Cables.....	2-3
CPU/Sound Board.....	2-4
Switcher Power Supply Assembly.....	2-5

### **Section 3 Diagrams and Schematics**

JAMMA Chart.....	3-2
Interboard Wiring Diagram.....	3-3
Power Wiring Diagram & Transformer Chart.....	3-4
Cabinet Wiring Diagram.....	3-5
Electronic Rack Assembly.....	3-6

Killer Instinct™

©1994 Nintendo/Rare

Game by Rare

Killer Instinct is a trademark of Nintendo

Manufactured and sold by Midway Manufacturing Company under license.





# KILLER INSTINCT

## SECTION one

### Operation

## SAFETY NOTICES

The following safety instructions apply to all game operators and service personnel. Specific warnings and cautions will be found throughout this manual where they apply. We recommend that you read this page before preparing your game for play.

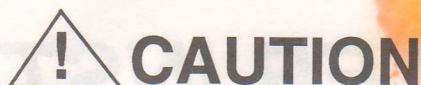

**HARD DRIVE.** The operator must order special a shipping box and anti-static bag from the distributor in order to send the hard drive in for repair or replacement.

Shipping Box #08-7936, Anti-Static Bag #20-9638-3

**AC POWER CONNECTION.** Before connecting the game to the AC power source, verify the Voltage Selection Chart jumper wires are installed correctly for the line voltage in your area. For details refer to Section 3.

**PROPERLY GROUND THE GAME.** To avoid electrical shocks, do not plug in the game until it has been inspected and properly grounded. MIDWAY games should only be plugged into a grounded 3-wire outlet.

NOTE: The control panel is removable. Ensure that the ground braid is securely attached to the control panel after servicing.

**DISCONNECT POWER DURING REPAIRS.** To avoid electrical shock, disconnect the game from the AC power source before removing or repairing any part of the game.

**USE THE PROPER FUSES.** To avoid electrical shock, use the replacement fuses which are specified on the inside back cover. The replacement fuses must match the original fuses in fuse type, voltage rating, and current rating.

**MONITOR PRECAUTIONS.** When removing or repairing the monitor, extra precautions must be taken to avoid electrical shock because high voltages may exist within the monitor circuitry and cathode ray tube (CRT) even after power has been disconnected. Do not touch internal parts of the monitor with you hands or metal objects! Always discharge the CRT by the following method: Attach one end of a large, well-insulated, 20kV jumper to ground. Momentarily touch the free end of the grounded jumper to the anode by sliding it under the anode cap. Wait two minutes and discharge the anode again.

**HANDLE FLUORESCENT TUBE AND CRT WITH CARE.** If you drop a fluorescent tube or CRT and it breaks, it will implode! Shattered glass can fly eight feet or more from the implosion.

## ATTENTION !

**PROPERLY ATTACH ALL CONNECTORS.** *Be sure that the connectors on each printed circuit board (PCB) are properly connected. If they do not slip on easily, do not force them. A reversed connector may damage your game and void the warranty. All connectors are keyed to fit specific pins on each board.*

---

---

## SETUP PROCEDURE

### INSTALLATION & INSPECTION

<b>Game Location Requirements</b>	<u>Power</u> Domestic 120V @ 60 Hz Foreign 230V @ 50 Hz	<u>Temp</u> 32° F to 100° (0° C to 38° C)	<u>Humidity</u> Not to exceed 95% relative.
-----------------------------------	---	---	--

<b>Cabinet Statistics</b>	<u>Dimensions</u> Width 27" Depth 41" Height 73"	<u>Weight</u> Approximately 402lbs
---------------------------	---	---------------------------------------

1. Remove all items from the shipping containers and set them aside. Inspect the exterior of the cabinet and the control panel for any damage.
2. The coin door keys are attached to one of the joysticks. Unlock and open the coin and cash box doors. Remove the spare parts stored in the cash box and remove the rear door keys located on a key hook inside the coin door.
3. Remove the screws holding the rear door then unlock and remove the door. Inspect the cabinet interior for any signs of damage. Check all major assemblies to assure that they are mounted securely.
4. Refer to the Cabinet Wiring Diagram (Section 3), and check to see that all cable connectors are correctly secured. *Do not force connectors.* Watch for damaged connectors and avoid making reversed connections.
5. If a padlock is desired, turn the rear door hasp so that it protrudes from the hole in the back of the cabinet. Remove the two nuts inside the cabinet, at the top and middle of the rear door opening. Then slide the hasp off of the bolts. Turn the hasp, slide it back on the bolts and replace the nuts.
6. Next, locate the four leg levelers among the spare parts in the cash box. There are four threaded holes on the bottom of the cabinet; one in each corner. Place one leg leveler (with its hex nut) in each of the threaded holes. Lower each leg leveler until the cabinet is stable and level.

### **!! WARNING !!**

**The cabinet is top heavy.**

7. Determine the value of your line voltage with a meter. Then, check the jumper wires to the main power supply transformer. Be sure it is jumpered to correspond to your local line voltage value. If necessary, change the jumper wires to the transformer in accordance with the Voltage Selection Chart in Section 3.
8. Lay the line cord (connected to the power chassis) in the slot along the bottom edge of the rear cabinet door. Replace the rear door and screw (lock) it securely. NOTICE: Tamper proof screws are included in the spare parts bag. These screws are optional and may be used to secure the rear door panel. A special wrench (20-9620) for the installation of tamper proof screws is also provided. Close and lock the front coin and cash box doors.
9. Plug the game into a grounded (3-terminal) AC wall outlet. Switch ON the game, using the ON/OFF switch located on the upper left rear of the cabinet.

# CABINET ASSEMBLY

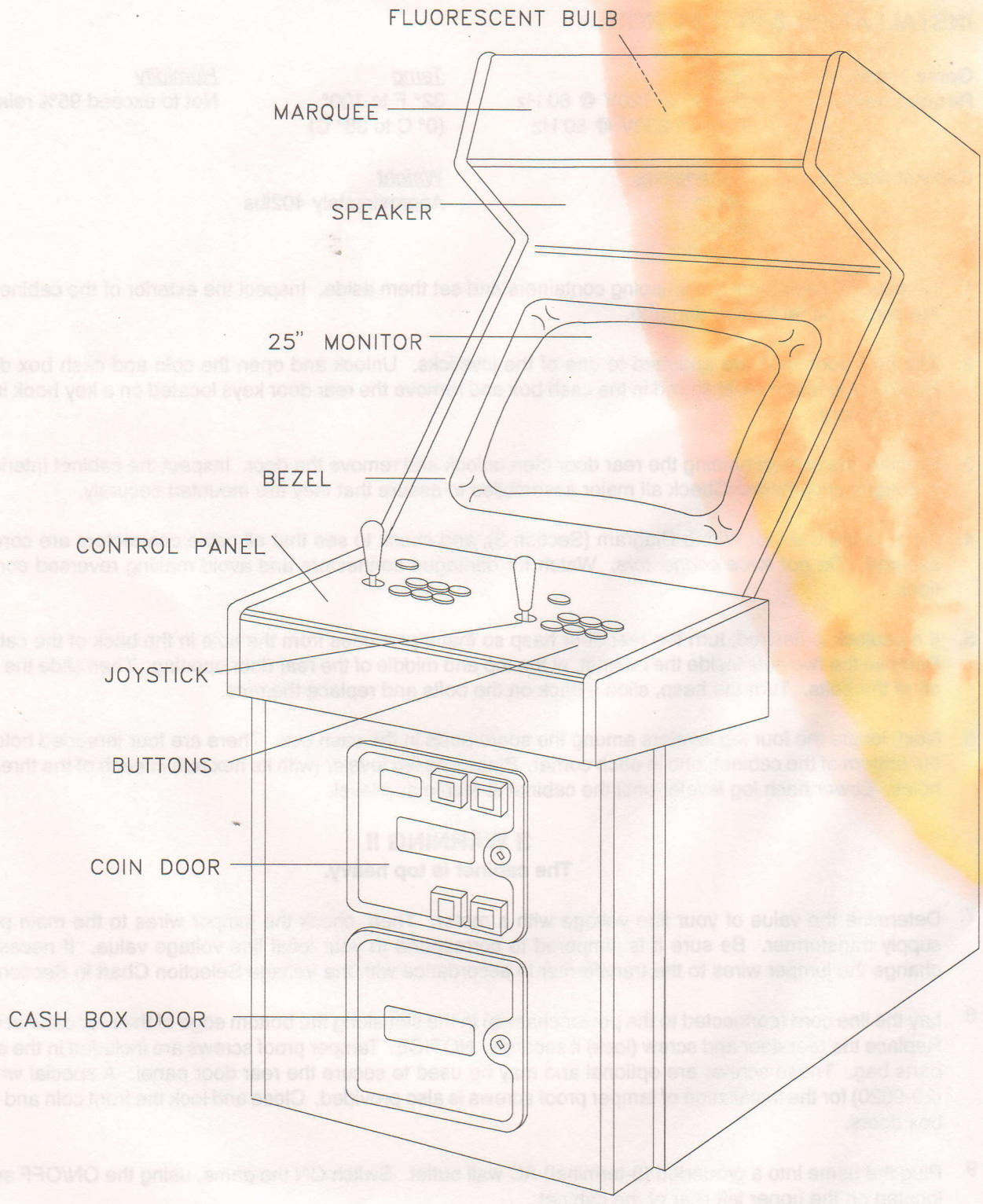

Front View

# CABINET ASSEMBLY

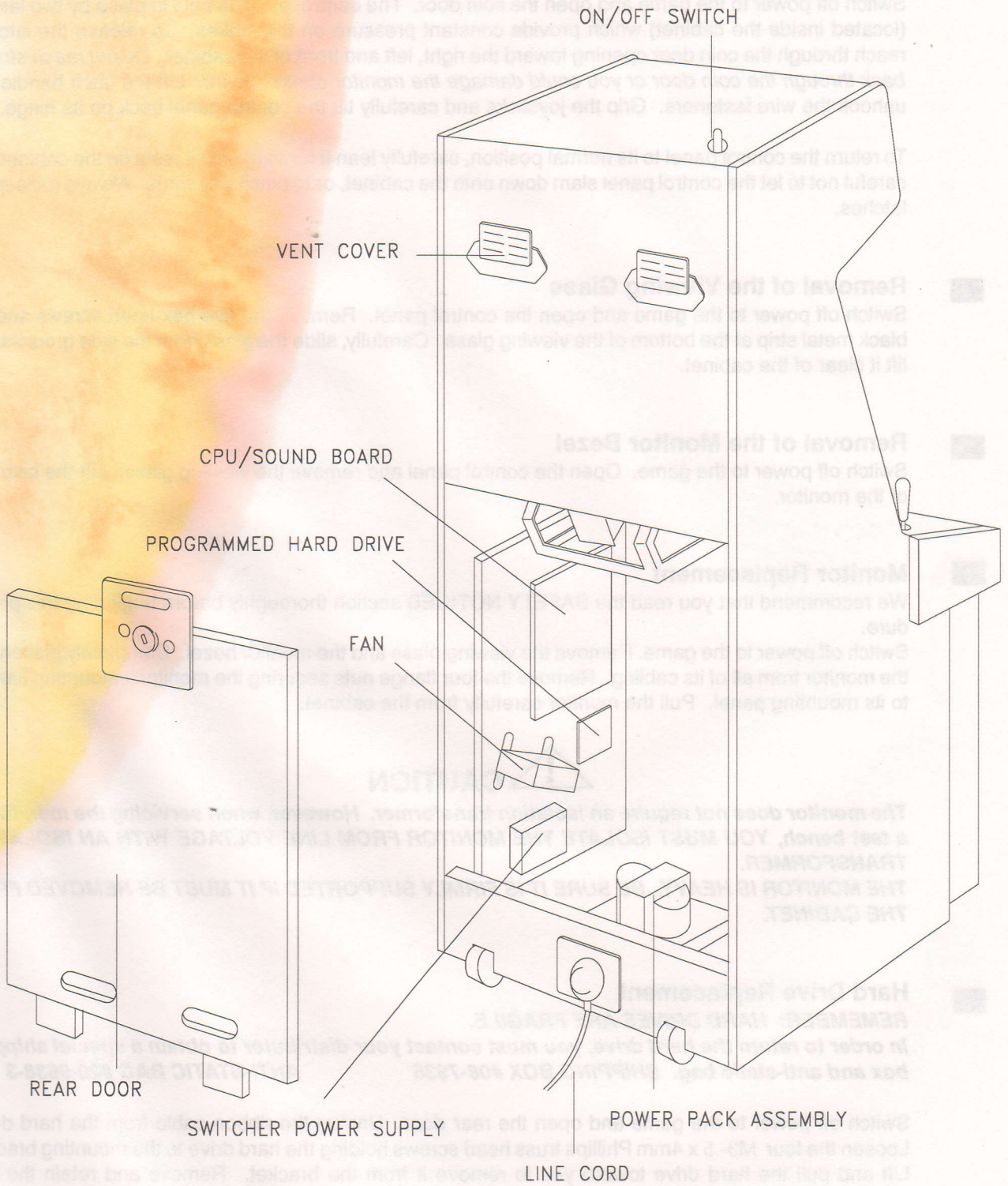

Rear View  
1-5

---

---

## SERVICING

### ■ Servicing the Control Panel

Switch off power to the game and open the coin door. The control panel is held in place by two latches (located inside the cabinet) which provide constant pressure on the strikes. To release the latches, reach through the coin door opening toward the right, left and front of the cabinet. *Do not reach straight back through the coin door or you could damage the monitor control board.* Lift the latch handle and unhook the wire fasteners. Grip the joysticks and carefully tilt the control panel back on its hinge.

To return the control panel to its normal position, carefully lean it forward until it rests on the cabinet. Be careful not to let the control panel slam down onto the cabinet, or to pinch any wires. Always reclip the latches.

### ■ Removal of the Viewing Glass

Switch off power to the game and open the control panel. Remove the five hex-head screws and the black metal strip at the bottom of the viewing glass. Carefully, slide the glass from the side grooves and lift it clear of the cabinet.

### ■ Removal of the Monitor Bezel

Switch off power to the game. Open the control panel and remove the viewing glass. Lift the bezel off of the monitor.

### ■ Monitor Replacement

We recommend that you read the SAFETY NOTICES section thoroughly before beginning this procedure.

Switch off power to the game. Remove the viewing glass and the monitor bezel. Completely disconnect the monitor from all of its cabling. Remove the four flange nuts securing the monitor's mounting flanges to its mounting panel. Pull the monitor carefully from the cabinet.



### CAUTION

*The monitor does not require an isolation transformer. However, when servicing the monitor on a test bench, YOU MUST ISOLATE THE MONITOR FROM LINE VOLTAGE WITH AN ISOLATION TRANSFORMER.*

*THE MONITOR IS HEAVY. BE SURE IT IS FIRMLY SUPPORTED IF IT MUST BE REMOVED FROM THE CABINET.*

### ■ Hard Drive Replacement

**REMEMBER: HARD DRIVES ARE FRAGILE.**

*In order to return the hard drive, you must contact your distributor to obtain a special shipping box and anti-static bag. SHIPPING BOX #08-7936                      ANTI-STATIC BAG #20-9638-3*

Switch off power to the game and open the rear door. Unplug the ribbon cable from the hard drive. Loosen the four M3-.5 x 4mm Phillips truss head screws holding the hard drive to the mounting bracket. Lift and pull the hard drive toward you to remove it from the bracket. Remove and retain the four screws.

Open the shipping box. Remove the top white foam packing and anti-static bag, set them aside. Remove the center two inserts from the gray foam packing. This creates an opening approximately 4" x 2-3/4". Place the hard drive in the anti-static bag and then in the opening in the gray foam packing. Replace the white foam packing so that the bubble side faces up. Seal the box.

To reinstall the hard drive, first screw the four M3-.5 x 4mm Phillips truss head screws about half way into the drive. Arrange the hard drive so that the PC board faces the mounting bracket and the ribbon cable connector points up. Line the screws up with the slots and slide it back and down, into the lock position on the bracket. Tighten the screws. Plug in the ribbon cable from the CPU/Sound board.

NOTE: The ribbon cable connector is keyed. Pin 1 of the ribbon cable has a red line going to it. The connector on the hard drive is fragile. Do not force the ribbon cable connector onto the hard drive connector.

### ■ Removal of the Marquee

Switch off power to the game. Remove the hex-head screws from the black marquee retaining strip located on top of the header. Remove the strip and carefully lift the marquee and the marquee glass from the top of the header. Store the marquee carefully to prevent damage.

### ■ Removal of the Fluorescent Light Assembly

Switch off power to the game. Remove the marquee glass and the marquee. The fluorescent bulb is now accessible for replacement. Remove the plastic lamp locks. Grasp the bulb, give it a quarter turn, and remove it from its socket. Carefully, place a new bulb into the socket, and turn to reinstall.

To remove the entire light fixture, disconnect the fluorescent light assembly from its power cable. Remove the screws that hold the assembly to the cabinet then lift out the assembly.

### !! WARNING !!

If you drop a fluorescent tube and it breaks, it will implode! Use care in handling.

### ■ Removal of the Speakers

Switch off power to the game. Remove the marquee and the marquee glass. The speakers come out from the front of the cabinet. Be sure to disconnect the cabling and remove the nuts on the mounting screws before attempting to remove the speakers from the enclosure. Carefully, reinstall the seals upon completing any task in the speaker enclosure.

### ■ Volume Control, Begin Test Switch, and Service Credit Switch

Open the coin door. The game's volume control and diagnostic push-button switches are located on a small bracket on the door. The volume is controlled by the two center buttons. Press the Volume Up or the Volume Down button until the desired sound level is reached. The Begin Test switch, on the right, activates the game's menu system. The Service Credit switch, on the left, allows credits to be allotted for service testing without affecting the game's bookkeeping total.

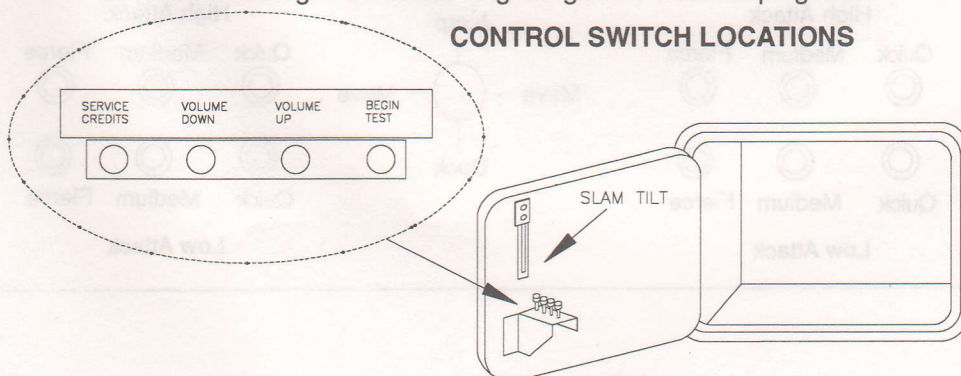

# GAME FEATURES

## STARTING UP

Switch on power to the game. The game runs through a start-up routine. Insert the desired amount of coins, bills or tokens. Select which player receives the credit by pressing the appropriate Start button.

### NOTE

When an error is detected during the Start-up tests, game start-up does not progress, and an error message appears on the screen.

## PLAYER CONTROLS

### Start Button

Each player has a Start button. The Start buttons allow one or two players to begin or continue play.

### Joysticks

Each player has a joystick which he uses to control an on-screen character. The player can make the on-screen character move, jump or duck.

### High Attack

An attack that originates above the waist, such as a punch.

### Low Attack

An attack that originates below the waist, such as a kick.

### Quick

A "quick" attack is a short range, short duration attack that inflicts little damage to an opponent.

### Medium

A "medium" attack is a moderate range, moderate duration attack that inflicts some damage to an opponent.

### Fierce

A "fierce" attack is a long range, long duration attack that inflicts much damage to an opponent.

### NOTE

Use joystick and button combinations to discover secret moves.

## CONTROL PANEL DIAGRAM

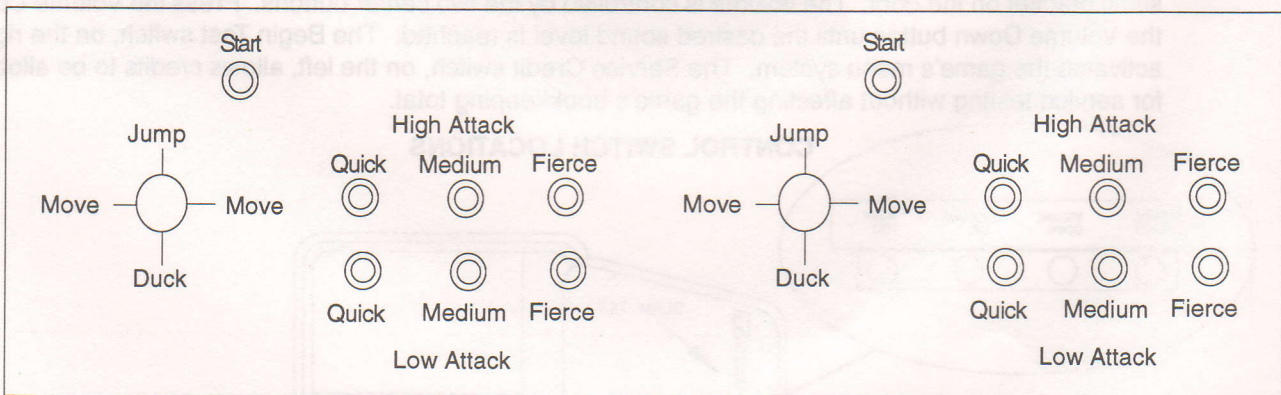

## GAME OPERATION

The **KILLER INSTINCT** Control switches are located inside the coin door.

### CONTROL SWITCHES

Control switches are located on a bracket inside the coin door.

The **Slam Tilt** switch prevents pounding for free games.

The **Volume Down** and **Volume Up** push-button switches increase or decrease the volume level of the music and speech. The volume level can be adjusted during the Attract Mode or during menu system operation. For greater profits, set your game's volume level at a nice loud setting.

The **Begin Test** push-button switch enters the game's menu system. Press the Begin Test switch to access any of the menu system functions.

The **Service Credit** push-button switch is a special feature switch that allots credit without affecting the game's bookkeeping total.

### NOTE

*The coin door must be open for the control switches to work.*

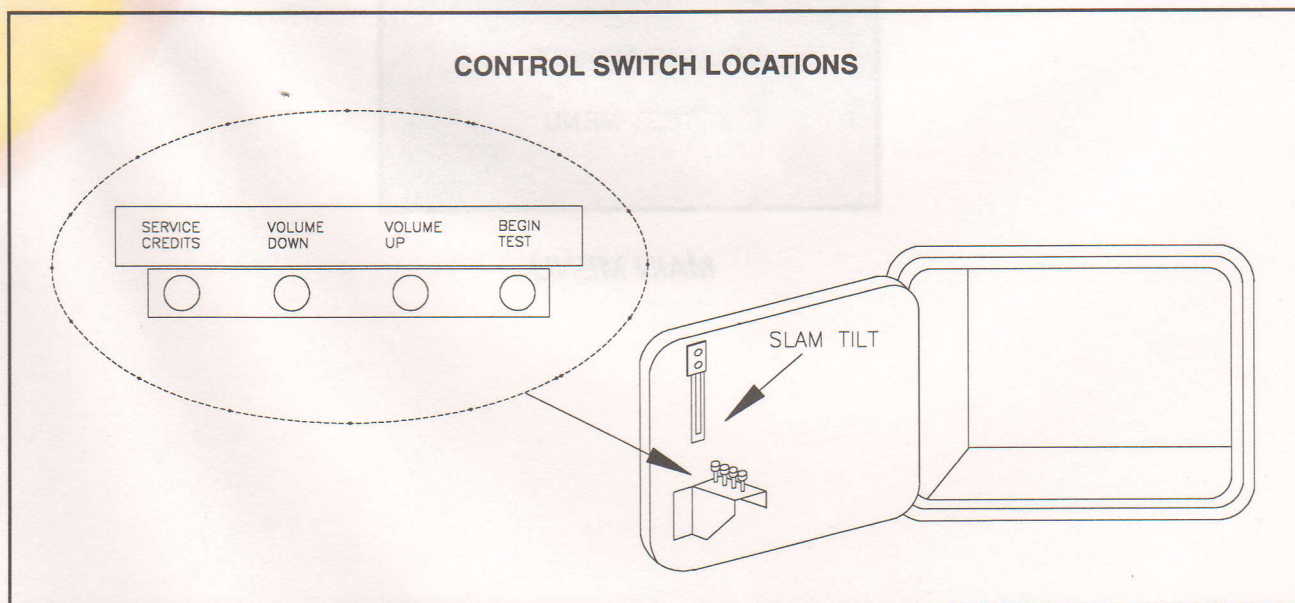

---

---

## MENU SYSTEM OPERATION

### OPERATION

All game audits, adjustments and diagnostics are options of the Main Menu. Each option, in turn, has its own menu that lists several choices which you may act upon as desired.

Press the Begin Test switch on the coin door to open the Main Menu (shown below). Game adjustments, bookkeeping and diagnostics are all accessible from this menu.

Use either joystick to move the cursor up and down the menu screen. Notice that the options are highlighted in sequence. Press any button to open a highlighted option. *Only highlighted options can be opened.*

To exit the Main Menu, use either joystick to select EXIT TO GAME OVER and press any button.



**KILLER INSTINCT**  
VERSION X.X

DIAGNOSTIC TEST  
COIN BOOKKEEPING  
GAME AUDITS  
GAME ADJUSTMENTS  
UTILITIES  
VOLUME ADJUST  
EXIT TEST MENU

MAIN MENU

## DIAGNOSTIC TESTS

Use either joystick to select the Diagnostic Menu and any button to open it. Then, use either joystick to move the cursor up and down the menu and any button to open a highlighted option.

### KILLER INSTINCT

SWITCH TEST  
DIP SWITCH TEST  
CPU BOARD TEST  
SOUND BOARD TEST  
MONITOR PATTERNS  
BURN-IN TEST  
CHECK DISK  
RETURN TO MAIN MENU

### DIAGNOSTIC MENU

#### Switch Test

The Switch Test allows the operator to test the switches on the control panel and in the coin door.

Use either joystick to highlight the Switch Test and any button to begin the test.

During the Switch Test the top of the screen shows the control panel switches while the bottom of the screen shows the coin door switches. Press a control panel or coin door switch and the switch location on the screen lights. Release the switch and the screen returns to normal.

To exit the Switch Test, press both Start buttons together.

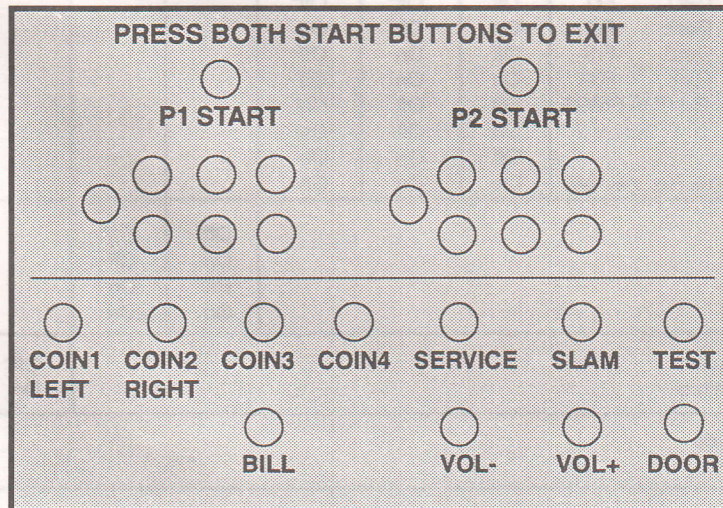

### SWITCH TEST SCREEN

## DIP Switch Test

The DIP Switch Test allows the operator to check or change the position of the DIP Switches on the CPU Board.

Use either joystick to select the DIP Switch Test and press any button to access the DIP Switch Setting Tables. The screen displays the current DIP Switch settings. To change a setting, slide the switch to the desired position, then check the screen to verify the new setting. *In some cases, setting a function to OFF actually enables the function. For example, setting DIP Switch Coinage to Off enables DIP Switch Coinage.*

Press any button to return to the Diagnostic Menu.

### DIP Switch 1 Setting Table

	SW1	SW2	SW3	SW4	SW5	SW6	SW7	SW8
High Blood Level	Off*	Off*						
Med. Blood Level	On	Off						
Low Blood Level	Off	On						
No Blood	On	On						
Attract Sounds			Off*					
No Attract Sounds			On					
Ending Moves				Off*				
No Ending Moves				On				
Display Violence Warning					Off*			
No Violence Warning					On			
Not Used						Off*	Off*	Off*
						On	On	On

### DIP Switch 2 Setting Table

	SW1	SW2	SW3	SW4	SW5	SW6	SW7	SW8
DIP Sw. Coinage	Off*							
Disk Coinage	On							
<b>Coin Settings</b>								
USA1	Ger1	Fr1	Off*	Off*	Off*			
USA2	Ger2	Fr2	On	Off	Off			
USA3	Ger3	Fr3	Off	On	Off			
USA4	Ger4	Fr4	On	On	Off			
USAECA	GerECA	FrECA	Off	Off	On			
USA9			On	Off	On			
USA10			Off	On	On			
Free Play	Free Play	Free Play	On	On	On			
<b>Country</b>								
USA					Off*	Off*		
Germany					On	Off		
France					Off	On		
Not Used					On	On		
One Counter							Off*	
Two Counters							On	
Game Mode								Off*
Test Mode								On

\* Indicates Factory Setting.

## CPU Board Test

Select the CPU Board Test with either joystick then press any button to start the automatic test. When this test is activated, a "rug" pattern appears on the screen. When the rug pattern ends, *Test O.K.* or *Test Failed* appears on the screen. This test returns to the Diagnostic Menu automatically.

## Sound Board Test

This test allows the operator to listen to some of the sounds this game is capable of producing.

Use either joystick to select the test, then press any button to open the test menu. The screen displays two test options. Use either joystick to select an option and press any button to begin the test.

### KILLER INSTINCT

GENERAL SOUND TEST

PLAY SAMPLES

BACK TO DIAGNOSTIC MENU

RETURN TO MAIN MENU

### SOUND TEST MENU

**GENERAL TEST** analyzes the sound circuitry. The screen shows a list of error codes. A successful test causes a single "tone" to sound. Detection of a fault causes a series of tones or no tone at all to sound. Press any button to return to the Sound Test Menu.

0 TONES	-	CHECK HARDWARE
1 TONE	-	ALL O.K.
2 TONES	-	BAD U10 CHECKSUM
3 TONES	-	BAD U11 CHECKSUM
4 TONES	-	BAD U12 CHECKSUM
5 TONES	-	BAD U13 CHECKSUM
6 TONES	-	BAD U33 CHECKSUM
7 TONES	-	BAD U34 CHECKSUM
8 TONES	-	BAD U35 CHECKSUM
9 TONES	-	BAD U36 CHECKSUM
10 TONES	-	RAM TEST FAILED

**PLAY SOUNDS** test synthesized and digitized sounds from the CPU/Sound Board. Advance to the next sound with any button. Use either joystick to end the test.

Select RETURN TO MAIN MENU or BACK TO DIAGNOSTIC MENU and press any button.

## Monitor Patterns

The Monitor Patterns Test provides a menu for testing the monitor.

Select the test with either joystick. Press any button to open the test menu. Once the Monitor Patterns Test menu is open, use either joystick to select an option, and any button to begin it.

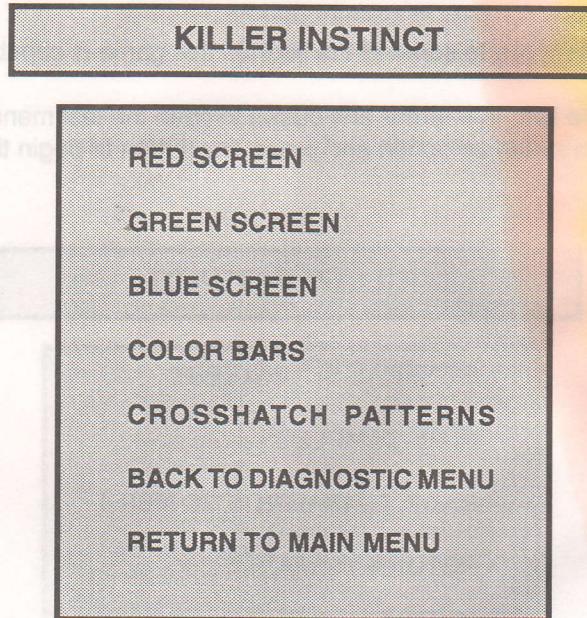

### *MONITOR PATTERNS MENU*

The **RED, GREEN** and **BLUE SCREEN** tests fill the screen with either red, green or blue. Press any button to return to the Monitor Patterns Menu.

The **COLOR BARS** test fills the screen with several shades of colors to help with red, green and blue level adjustments. Each color should appear sharp and clear. Press any button to return to the Monitor Patterns Menu.

The **CROSSHATCH PATTERNS** test fills the screen with a grid and a series of dots. The grid and the dots should be clear. The dots should be round. Press any button to return to the Monitor Patterns Menu.

If any of the Monitor Patterns Test shows a need for adjustment, use the proper knobs on the Monitor Controls Board.

Use either joystick to select **RETURN TO MAIN MENU** or **BACK TO DIAGNOSTIC MENU**, then press any button.

### Check Disk

This test checks the hard disk drive.

Use either joystick to select the test, then press any button to activate it. Press any button to return to the Diagnostic Menu.

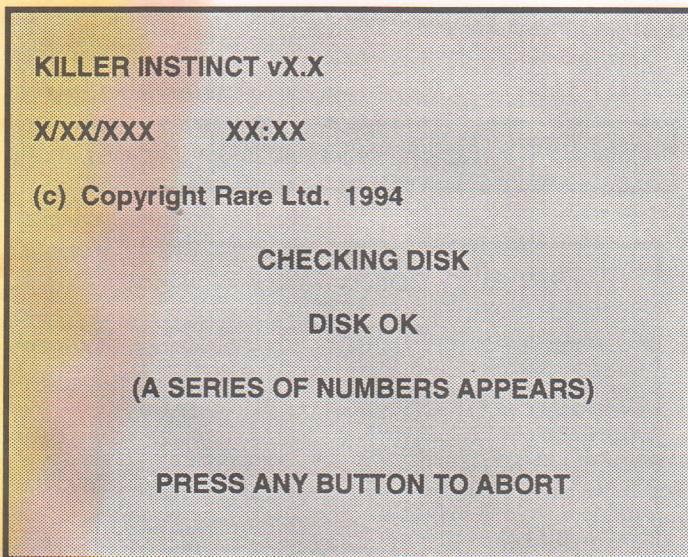

*CHECK DISK SCREEN*

### Burn-in Test

The Burn-in Test continually repeats the CPU Board Test. Use this test to find intermittent CPU Board problems.

Use either joystick to select the test, then press any button to activate it. When the Burn-in Test detects an error the test stops and an error message is displayed on the screen. To exit this test, switch the game off, then on again.

The Audit Table specifies the number of Burn-in cycles that have been successfully completed.

## COIN BOOKKEEPING

The Coin Bookkeeping Table records the coin box totals and the game play counters.

Use either joystick to select the Coin Bookkeeping Menu, then press any button to open it.

To exit Coin Bookkeeping, use either joystick to select RETURN TO MAIN MENU and press any button.

KILLER INSTINCT	
LEFT SLOT COINS	0
RIGHT SLOT COINS	0
3RD SLOT COINS	0
4TH SLOT COINS	0
BILLS	0
SERVICE CREDITS	0
BONUS CREDITS	0
PAID CREDITS	0
TOTAL CREDITS	0
RETURN TO MAIN MENU	

*COIN BOOKKEEPING MENU*

## GAME AUDITS

Use joystick to select the Game Audits Menu, then press any button to open it. Page through the available audits by selecting NEXT AUDIT PAGE or LAST AUDIT PAGE. Select RETURN TO MAIN MENU and press any button to exit Game Audits.

### NOTE

Game audits cannot be set. They can only be cleared.

#### KILLER INSTINCT

1 PLAYER GAMES	0
2 PLAYER GAMES	0
FREE PLAY GAMES	0
TOTAL GAMES	0
1 PLAYER CONTINUES	0
2 PLAYER CONTINUES	0
TOTAL GAME TIME	0:0:00
TOTAL TIME ON	0:0:00
AVERAGE 1P GAME TIME	0 (SECS)
AVERAGE 2P GAME TIME	0 (SECS)
NUMBER GAME INTERRUPTS	0
COMPLETED GAMES	0
NO. SUCCESSFUL BURN-IN LOOPS	0

NEXT AUDIT PAGE  
RETURN TO MAIN MENU

AUDIT MENU - PAGE ONE

#### GENERAL STATS

	1P	WINS	2P	WINS	TOTAL
COMBO	0	0%	0	0%	0
JAGO	0	0%	0	0%	0
THUNDER	0	0%	0	0%	0
GLACIUS	0	0%	0	0%	0
ORCHID	0	0%	0	0%	0
CINDER	0	0%	0	0%	0
SABREWOLF	0	0%	0	0%	0
RIPTOR	0	0%	0	0%	0
FULGORE	0	0%	0	0%	0
SPINAL	0	0%	0	0%	0
EYEDOL	0	0%	0	0%	0

NEXT AUDIT PAGE  
LAST AUDIT PAGE  
RETURN TO MAIN MENU

AUDIT MENU - PAGE TWO

Game Audits Continued...

COMBO STATS				
OPPONENT	1P		2P	
	GAMES	WINS	GAMES	WINS
COMBO	0	0%	0	0%
JAGO	0	0%	0	0%
THUNDER	0	0%	0	0%
GLACIUS	0	0%	0	0%
ORCHID	0	0%	0	0%
CINDER	0	0%	0	0%
SABREWULF	0	0%	0	0%
RIPTOR	0	0%	0	0%
FULGORE	0	0%	0	0%
SPINAL	0	0%	0	0%
EYEDOL	0	0%	0	0%

NEXT AUDIT PAGE  
 LAST AUDIT PAGE  
 RETURN TO MAIN MENU

AUDIT MENU - PAGE THREE

JAGO STATS				
OPPONENT	1P		2P	
	GAMES	WINS	GAMES	WINS
COMBO	0	0%	0	0%
JAGO	0	0%	0	0%
THUNDER	0	0%	0	0%
GLACIUS	0	0%	0	0%
ORCHID	0	0%	0	0%
CINDER	0	0%	0	0%
SABREWULF	0	0%	0	0%
RIPTOR	0	0%	0	0%
FULGORE	0	0%	0	0%
SPINAL	0	0%	0	0%
EYEDOL	0	0%	0	0%

NEXT AUDIT PAGE  
 LAST AUDIT PAGE  
 RETURN TO MAIN MENU

AUDIT MENU - PAGE FOUR

THUNDER STATS				
OPPONENT	1P		2P	
	GAMES	WINS	GAMES	WINS
COMBO	0	0%	0	0%
JAGO	0	0%	0	0%
THUNDER	0	0%	0	0%
GLACIUS	0	0%	0	0%
ORCHID	0	0%	0	0%
CINDER	0	0%	0	0%
SABREWULF	0	0%	0	0%
RIPTOR	0	0%	0	0%
FULGORE	0	0%	0	0%
SPINAL	0	0%	0	0%
EYEDOL	0	0%	0	0%

NEXT AUDIT PAGE  
 LAST AUDIT PAGE  
 RETURN TO MAIN MENU

AUDIT MENU - PAGE FIVE

GLACIUS STATS				
OPPONENT	1P		2P	
	GAMES	WINS	GAMES	WINS
COMBO	0	0%	0	0%
JAGO	0	0%	0	0%
THUNDER	0	0%	0	0%
GLACIUS	0	0%	0	0%
ORCHID	0	0%	0	0%
CINDER	0	0%	0	0%
SABREWULF	0	0%	0	0%
RIPTOR	0	0%	0	0%
FULGORE	0	0%	0	0%
SPINAL	0	0%	0	0%
EYEDOL	0	0%	0	0%

NEXT AUDIT PAGE  
 LAST AUDIT PAGE  
 RETURN TO MAIN MENU

AUDIT MENU - PAGE SIX

ORCHID STATS				
OPPONENT	1P		2P	
	GAMES	WINS	GAMES	WINS
COMBO	0	0%	0	0%
JAGO	0	0%	0	0%
THUNDER	0	0%	0	0%
GLACIUS	0	0%	0	0%
ORCHID	0	0%	0	0%
CINDER	0	0%	0	0%
SABREWULF	0	0%	0	0%
RIPTOR	0	0%	0	0%
FULGORE	0	0%	0	0%
SPINAL	0	0%	0	0%
EYEDOL	0	0%	0	0%

NEXT AUDIT PAGE  
 LAST AUDIT PAGE  
 RETURN TO MAIN MENU

AUDIT MENU - PAGE SEVEN

CINDER STATS				
OPPONENT	1P		2P	
	GAMES	WINS	GAMES	WINS
COMBO	0	0%	0	0%
JAGO	0	0%	0	0%
THUNDER	0	0%	0	0%
GLACIUS	0	0%	0	0%
ORCHID	0	0%	0	0%
CINDER	0	0%	0	0%
SABREWULF	0	0%	0	0%
RIPTOR	0	0%	0	0%
FULGORE	0	0%	0	0%
SPINAL	0	0%	0	0%
EYEDOL	0	0%	0	0%

NEXT AUDIT PAGE  
 LAST AUDIT PAGE  
 RETURN TO MAIN MENU

AUDIT MENU - PAGE EIGHT

SABREWULF STATS				
OPPONENT	1P		2P	
	GAMES	WINS	GAMES	WINS
COMBO	0	0%	0	0%
JAGO	0	0%	0	0%
THUNDER	0	0%	0	0%
GLACIUS	0	0%	0	0%
ORCHID	0	0%	0	0%
CINDER	0	0%	0	0%
SABREWULF	0	0%	0	0%
RIPTOR	0	0%	0	0%
FULGORE	0	0%	0	0%
SPINAL	0	0%	0	0%
EYEDOL	0	0%	0	0%

NEXT AUDIT PAGE  
LAST AUDIT PAGE  
RETURN TO MAIN MENU

AUDIT MENU - PAGE NINE

RIPTOR STATS				
OPPONENT	1P		2P	
	GAMES	WINS	GAMES	WINS
COMBO	0	0%	0	0%
JAGO	0	0%	0	0%
THUNDER	0	0%	0	0%
GLACIUS	0	0%	0	0%
ORCHID	0	0%	0	0%
CINDER	0	0%	0	0%
SABREWULF	0	0%	0	0%
RIPTOR	0	0%	0	0%
FULGORE	0	0%	0	0%
SPINAL	0	0%	0	0%
EYEDOL	0	0%	0	0%

NEXT AUDIT PAGE  
LAST AUDIT PAGE  
RETURN TO MAIN MENU

AUDIT MENU - PAGE TEN

FULGORE STATS				
OPPONENT	1P		2P	
	GAMES	WINS	GAMES	WINS
COMBO	0	0%	0	0%
JAGO	0	0%	0	0%
THUNDER	0	0%	0	0%
GLACIUS	0	0%	0	0%
ORCHID	0	0%	0	0%
CINDER	0	0%	0	0%
SABREWULF	0	0%	0	0%
RIPTOR	0	0%	0	0%
FULGORE	0	0%	0	0%
SPINAL	0	0%	0	0%
EYEDOL	0	0%	0	0%

NEXT AUDIT PAGE  
LAST AUDIT PAGE  
RETURN TO MAIN MENU

AUDIT MENU - PAGE ELEVEN

OPPONENT	SPINAL STATS			
	1P		2P	
	GAMES	WINS	GAMES	WINS
COMBO	0	0%	0	0%
JAGO	0	0%	0	0%
THUNDER	0	0%	0	0%
GLACIUS	0	0%	0	0%
ORCHID	0	0%	0	0%
CINDER	0	0%	0	0%
SABREWULF	0	0%	0	0%
RIPTOR	0	0%	0	0%
FULGORE	0	0%	0	0%
SPINAL	0	0%	0	0%
EYEDOL	0	0%	0	0%

NEXT AUDIT PAGE  
 LAST AUDIT PAGE  
 RETURN TO MAIN MENU

AUDIT MENU - PAGE TWELVE

OPPONENT	EYEDOL STATS			
	1P		2P	
	GAMES	WINS	GAMES	WINS
COMBO	0	0%	0	0%
JAGO	0	0%	0	0%
THUNDER	0	0%	0	0%
GLACIUS	0	0%	0	0%
ORCHID	0	0%	0	0%
CINDER	0	0%	0	0%
SABREWULF	0	0%	0	0%
RIPTOR	0	0%	0	0%
FULGORE	0	0%	0	0%
SPINAL	0	0%	0	0%
EYEDOL	0	0%	0	0%

NEXT AUDIT PAGE  
 LAST AUDIT PAGE  
 RETURN TO MAIN MENU

AUDIT MENU - PAGE THIRTEEN

## GAME ADJUSTMENTS

The Game Adjustments allow the operator to customize the game.

Use either joystick to select the Game Adjustments Menu. Press any button to open the menu.

The Game Adjustments Menu offers several options. Each option has several choices. Use either joystick to select an option, then press any button to open the option. The next menu screen provides a setting value. Use either joystick to change the setting value and press any button to lock it in.

To exit the Adjustments Menu, use either joystick to select RETURN TO MAIN MENU, then press any button.

### **NOTE**

*Adjustment values set by DIP SWITCH, override adjustment values set by the menu system.*

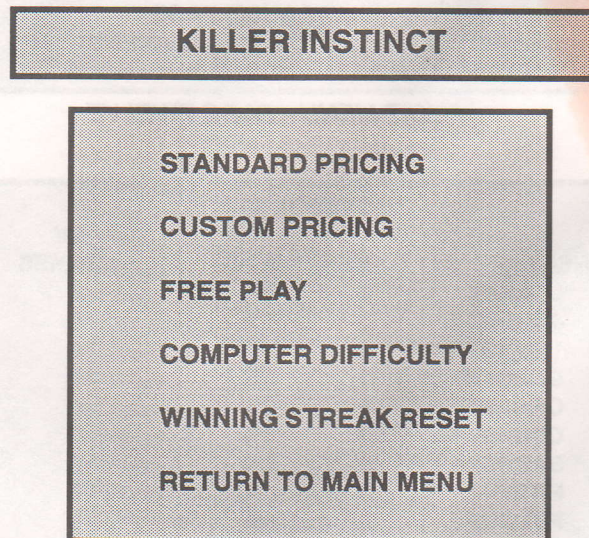

### GAME ADJUSTMENTS MENU

## Game Adjustments

### **Standard Pricing**

Standard pricing allow the operator to choose any of the "standard" selections from the Standard Pricing Table. See page 1-24.

Modify the setting value with either joystick. Press any button to lock in the new value and return to the Adjustments Menu.

### **Custom Pricing**

Custom pricing allows the operator to install pricing other than that of the Standard Pricing Table. Custom pricing also allows the operator to select the maximum amount of credits per game, the amount of credits required to start a game, and the amount of credits required to continue a game. This option is being adjusted from the DIP Switch settings. See page 1-25.

Modify the setting value with either joystick. Press any button to lock in a new value and return to the Adjustment Menu.



### STANDARD PRICING TABLE

Name	Setting - Credit/Coin	Coin 1	Coin 3	Coin 2	Coin 4	Bills
USA 1	1/25¢ (2 to Start; 2 to Continue)	25¢		25¢		\$1.00
USA 2	1/25¢ (2 to Start; 1 to Continue)	25¢		25¢		\$1.00
USA 3	1/25¢ (1 to Start; 1 to Continue)	25¢		25¢		\$1.00
USA 4	1/50¢, 3/\$1.00 (1 to Start; 1 to Continue)	25¢		25¢		\$1.00
USA 5	1/50¢, 4/\$1.00 (2 to Start; 1 to Continue)	25¢		25¢		\$1.00
USA 6	1/50¢ (1 to Start; 1 to Continue)	25¢		25¢		\$1.00
USA 7	1/50¢, 3/\$1.00 (1 to Start; 1 to Continue)	25¢		25¢		\$1.00
USA 8	1/50¢, 4/\$1.00 (2 to Start; 2 to Continue)	25¢		25¢		\$1.00
USA 9	1/25¢ (3 to Start; 2 to Continue)	25¢		25¢		\$1.00
USA 10	1/25¢ (3 to Start; 3 to Continue)	25¢		25¢		\$1.00
USA ECA	1/25¢, 4/\$1.00 (2 to Start; 2 to Continue)	\$1.00	10¢	25¢	5¢	\$1.00
German 1	1/1DM, 6/5DM	1DM		5DM		
German 2	1/1DM, 7/5DM	1DM		5DM		
German 3	1/1DM, 8/5DM	1DM		5DM		
German 4	1/1DM, 5/5DM	1DM		5DM		
German 5	1/1DM, 6/5DM	1DM		5DM		
German ECA	1/1DM, 2/2DM, 6/5DM	5DM	1DM	2DM		
France 1	2/5F, 5/10F	5F		10F		
France 2	2/5F, 4/10F	5F		10F		
France 3	1/5F, 3/10F	5F		10F		
France 4	1/5F, 2/10F	5F		10F		
France 5	2/5F, 5/10F, 11/2 x 10F	5F		10F		
France 6	2/5F, 4/10F, 9/2 x 10F	5F		10F		
France 7	1/5F, 3/10F, 7/2 x 10F	5F		10F		
France 8	1/5F, 2/10F, 5/2 x 10F	5F		10F		
France 9	1/3 x 1F, 2/5F	1F		5F		
France 10	1/2 x 1F, 3/5F	1F		5F		
France 11	1/3 x 1F, 2/5F, 5/2 x 5F	1F		5F		
France 12	1/2 x 1F, 3/5F, 7/2 x 5F	1F		FF		
France ECA	1/3 x 1F, 2/5F, 5/2 x 5F	1F	10F	5F		
Canada	1/2 x 25¢, 3/\$1.00	25¢		\$1.00		\$1.00
Swiss 1	1/1F, 6/5F	1F		5F		
Swiss 2	1/1F, 7/5F	1F		5F		
Swiss 3	1/1F, 8/5F	1F		5F		
Italy	1/500 lire	500 lire		500 lire		
UK 1	1/20P, 3/50P	20P		50P		
UK 2	2/20P, 5/50P	20P		50P		
UK ECA	1/20P, 3/50P, 7/£1.00	£1.00	20P	50P	10P	
UK Elec w/CCU	1/30P, 2/50P, 4/£1.00	£1.00	20P	50P	10P	
Spain 1	1/100 peseta, 6/500 peseta	100 peseta		500 peseta		
Spain 2	1/100 peseta, 5/500 peseta	100 peseta		500 peseta		
Australia 1	1/3 x 20¢, 2/\$1.00	20¢		\$1.00		
Australia 2	1/5 x 20¢, 1/\$1.00	20¢		\$1.00		
Japan 1	1/100 yen	100 yen		100 yen		
Japan 2	2/100 yen	100 yen		100 yen		
Austria 1	1/5 schilling, 2/10 schilling	5 schilling		10 schilling		
Austria 2	1/2 x 5 schilling, 3/2 x 10 schilling	5 schilling		10 schilling		
Belgium 1	1/20F	20F		20F		
Belgium 2	3/20F	20F		20F		
Belgium 3	2/20F	20F		20F		
Belgium ECA	1/20F	50F	5F	20F		
Sweden	1/3 x 1 krona, 2/5 krona	1 krona		5 krona		
New Zealand 1	1/3 x 20¢	20¢		20¢		
New Zealand 2	1/2 x 20¢	20¢		20¢		
Netherlands	1/1 HFI, 3/2.5 HFI	1 HFI		2.5 HFI		
Finland	1/1 markka	1 markka		1 markka		
Norway	1/2 x 1 krone, 3/5 x 1 krone	1 krone		1 krone		
Denmark	1/2 x 1 krone, 3/5 krone, 7/2 x 5 krone	1 krone		5 krone		
Antillies	1/25¢, 4/1 guilder	25¢		1 guilder		
Hungary	1/2 x 10 forint, 3/2 x 20 forint	10 forint		20 forint		

## KILLER INSTINCT

- (1) LEFT CHUTE UNITS
- (1) RIGHT CHUTE UNITS
- (1) CHUTE 3 UNITS
- (1) CHUTE 4 UNITS
- (1) BILL UNITS
- (2) UNITS/CREDITS
- (3) UNITS/BONUS
- (4) MINIMUM UNITS
- (5) CREDITS TO START
- (6) CREDITS TO CONTINUE
- (7) MAXIMUM CREDITS
- RETURN TO ADJ. MENU

### *CUSTOM PRICING MENU*

- (1) Coins inserted accumulate units. This adjustment specifies the number of units given for each coin in the fourth chute (see "units/credit").
- (2) This is the number of coin units required to buy one credit.
- (3) There is one bonus credit awarded after this many coin units have accumulated.
- (4) This is the minimum number of units required before any credits are awarded.
- (5) Each player needs this many credits to begin a game.
- (6) Each player needs this many credits to continue a game.
- (7) This is the limit for the credit counter. Additional coins inserted will be lost (factory setting: 30).

## UTILITIES

The Utilities Menu allows the operator to clear the game's bookkeeping memory.

Use either joystick to select the Utilities Menu, then press any button.

**KILLER INSTINCT**

- CLEAR CREDITS
- CLEAR COIN COUNTERS
- CLEAR GAME AUDITS
- RESET HIGH SCORE
- DEFAULT ADJUSTMENTS
- FULL FACTORY RESTORE
- RETURN TO MAIN MENU

*UTILITIES MENU*

Use either joystick to select a utility. Press any button to activate the selection. A dialogue box appears and the operator can choose to reset the utility. For example:

**CLEAR CREDITS?  
ARE YOU SURE?**

**YES  
NO**

Use either joystick to choose a setting value. Press any button to lock in the new setting value.

To exit the Utilities Menu, use either joystick to select RETURN TO MAIN MENU, then press any button.

## VOLUME ADJUST

The Volume Adjust feature allows the operator to determine the sound and music level of the game.

The volume level can be adjusted from either the Attract Mode or the Menu System. Press the Volume Up button to raise the volume level and the Volume Down button to lower the volume level. Either joystick can also be used to raise or low the volume level. The current volume level is shown with a red bar. Press the any button to return to the Main Menu.

### VOLUME ADJUST PRESS ANY BUTTON TO EXIT

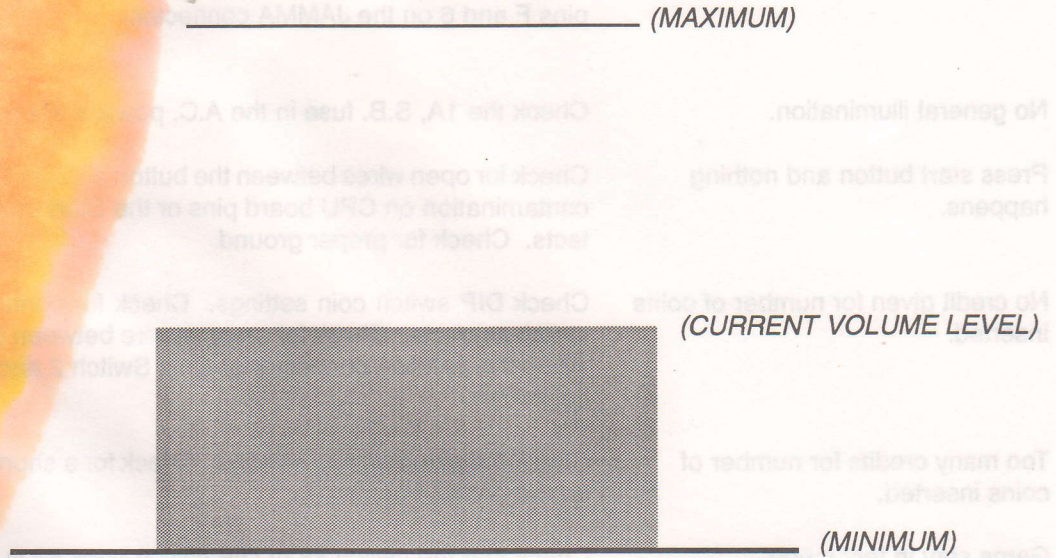

---

---

## TROUBLESHOOTING

### PROBLEM

No picture or distorted picture.

### POSSIBLE SOLUTION

Check for faulty video board or monitor. Check for disconnected video signal cable.

Turn game On and nothing happens.

Check line fuse. Check for +5Vdc at pins C, D, 3 and 4 of the JAMMA connector.

No sound.

Check the speaker and the speaker connection to pin L and 10 on the JAMMA connector. Check volume control setting. Check for +12Vdc at pins F and 6 on the JAMMA connector.

No general illumination.

Check the 1A, S.B. fuse in the A.C. power pack assembly.

Press start button and nothing happens.

Check for open wires between the button and the CPU board. Check for contamination on CPU board pins or the Start button switch blade contacts. Check for proper ground.

No credit given for number of coins inserted.

Check DIP switch coin settings. Check for contamination on the coin switch contacts. Check for an open wire between Coin Switch 1 and pin 16 on the JAMMA connector or Coin Switch 2 and pin T of the JAMMA connector.

Too many credits for number of coins inserted.

Check the game pricing settings. Check for a short between pins T & 16 on the JAMMA connector.

Game stay in test mode.

Check that the switch #8 of DIP switch bank #2 is set to off.



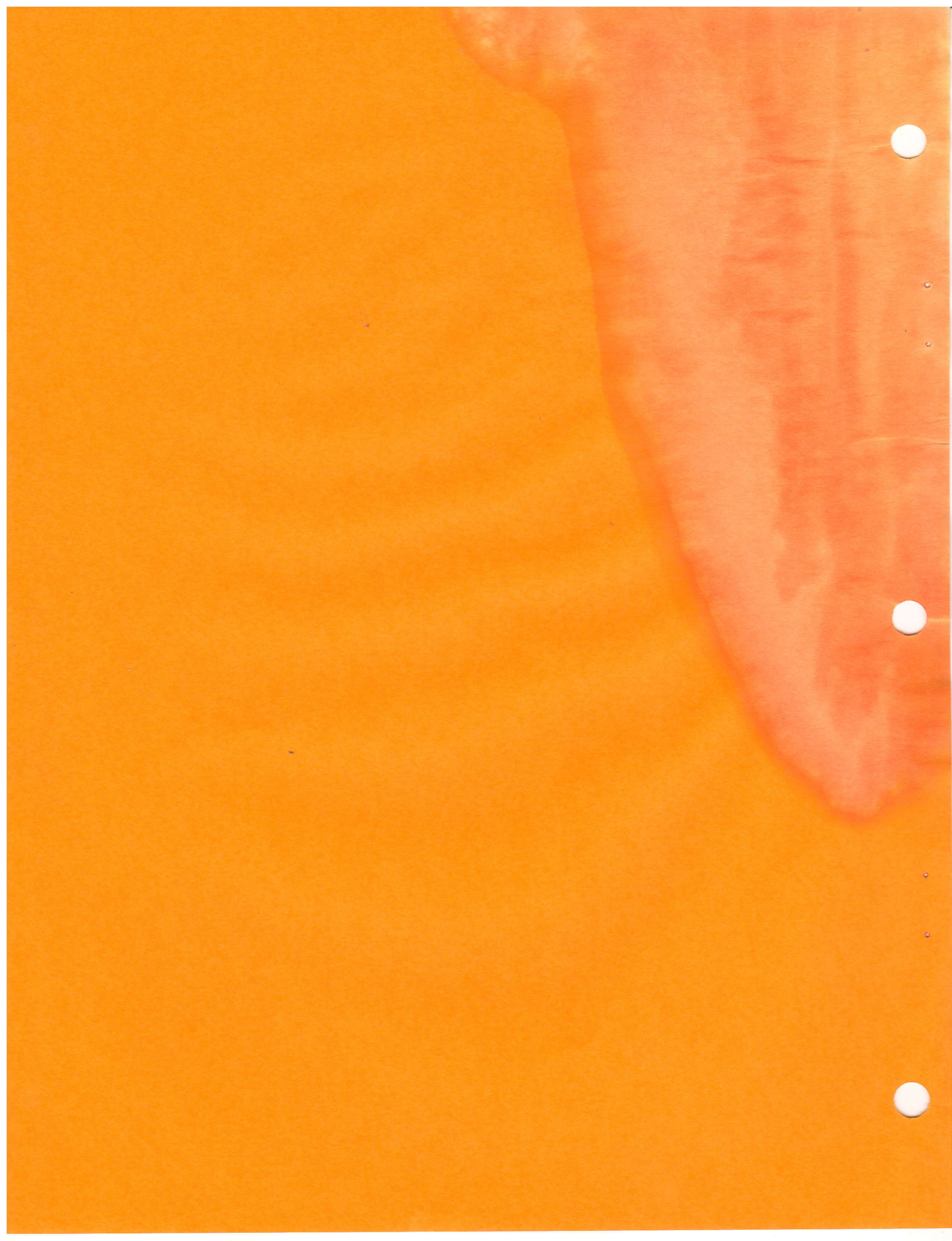

# KILLER INSTINCT

## SECTION two

### Parts

\* Before returning the  
distributor order  
Shipping box #08-7377  
and  
Anti-Static Bag #02-8038-8

A-18178-40047  
A-18178-40047  
A-18178-40047  
A-18178-40047  
A-18178-40047  
A-18178-40047  
A-18178-40047  
A-18178-40047

01-10819  
5875-13303-01

16-8037  
16-40047-101

---

---

## CABINET HARDWARE

Cabinet Assembly	A-19178-40047
Lock Retainer Plate	01-7264
Upper Door Lock Cam	01-8989
Leg Leveler Plate	01-9155
Lock Plate	01-11285
Door Bracket	01-11291
Shaft Caster	02-4404
20" Vent Hole Cover	03-7602
Door Cam Lock	20-6542-TB
Caster Wheel	20-9627
Coin Door Assembly	09-50000-33
Coin Vault Door	09-41000
Mars Chute	01-11379
Coin Meter w/Diode	5580-13476-00
Glass Retainer Bracket	01-9607.1
Security Bracket	01-11955
Marquee Retainer	03-8252-2
Glass Edge Retainer	03-8358
25" CRT Bezel	03-8497
Cash Box Tub	03-8863 (Qty = 2)
Leg Adjuster, 3 inch	08-7377 (Qty = 4)
Clear Marquee Glass	08-7456-4
Clear CRT Glass	08-7456-10
Marquee	31-2020

---

---

## ELECTRONIC RACK

Electronic Rack	A-19591	*Before returning hard drive to distributor order: Shipping Box #08-7936 and Anti-Static Bag #20-9638-3
Switcher Power Supply	A-15202-1	
CPU/Sound Assembly	A-19650-40047	
Hard Drive Mounting Bracket	A-19595.1	
Programmed Hard Drive*	A-19596	
Fan Grille	03-9223	
Fane Guard	20-9420	
Fan	20-9947	

---

---

## MONITOR

Monitor Support Bracket	01-10819
25" Monitor	5675-13399-01

---

---

## MANUALS

DBV Installation Instructions	16-9637
Instruction Manual	16-40047-101

---

---

---

---

## CONTROL PANEL

Housing & Control Panel Assembly	A-19584
Control Panel Assembly	A-19586
Plate	A-19587
Control Panel Cable	H-19597
Control Panel Latch Bracket	01-11996
Clear Overlay	03-9304
15 Link Safety Chain	20-9275-2
White Pushbutton	20-9687-2
Blue Pushbutton	20-9687-3
Control Panel Hinge	20-9841.1
8-Way Joystick	20-10178-3
Screened Overlay	31-2021
Housing w/ Hinge	A-19585
Toggle Latch	20-9347

---

---

## FLUORESCENT LAMP ASSEMBLY

Fluorescent Housing & Bracket	A-15890
Lamp Locks	03-8327
18" Fluorescent Bulb, 15W	24-8809

---

---

## SPEAKER

Speaker Grille	01-11859
8 $\Omega$ Full Range Speaker	5555-13961-00

---

---

## TRANSFORMER ASSEMBLY

Power Pack Assembly	A-15916
Fuse, SB, 1A, 250V	5731-06569-00
Fuse, SB, 3A, 250V	5731-10356-00

---

---

## CABLES

Dixie-Narco Cable	H-17019
Control Panel Cable	H-19597
Main Harness Cable	H-19598.1
Speaker Cable	H-19599
Line Voltage Cable	H-19639
2MM Ribbon Cable	5795-14459-02

---

---

# CPU/Sound Assembly A-19650-40047

Designation	Part Number	Description
U98	A-5343-40047-1	Game EPROM
U10	A-5343-40047-2	Sound EPROM
U11	A-5343-40047-3	Sound EPROM
U12	A-5343-40047-4	Sound EPROM
U13	A-5343-40047-5	Sound EPROM
U33	A-5343-40047-6	Sound EPROM
U34	A-5343-40047-7	Sound EPROM
U35	A-5343-40047-8	Sound EPROM
U36	A-5343-40047-9	Sound EPROM
S1, S2	5645-09025-00	DIP Switch
J3	5791-12461-10	Header, 10-pin
J6	5791-14457-00	Header, 44-pin
J7	5791-12461-15	Header, 15-pin
J8	5791-12461-08	Header, 8-pin

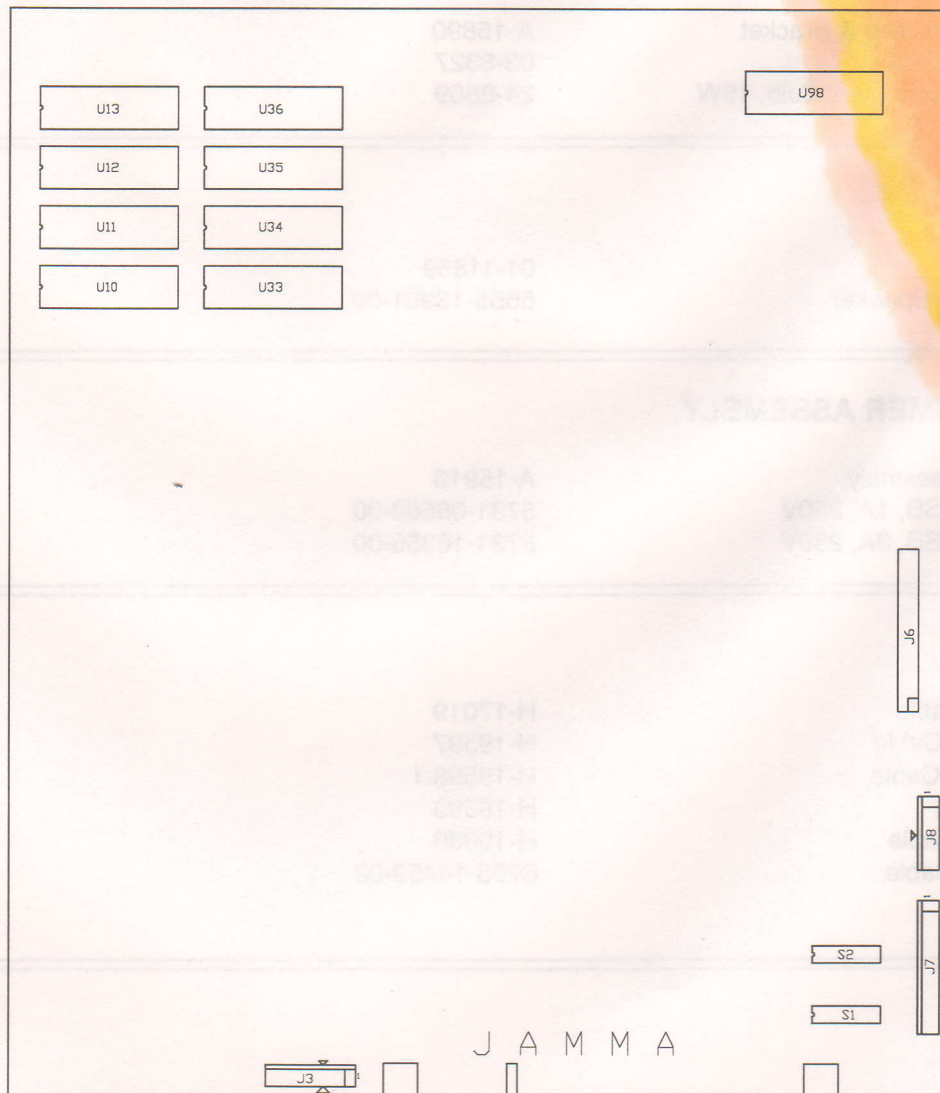

# Switcher Power Supply Assembly A-15202-1

Part Number	Description
01-10500	Mounting Bracket
01-12162	Shield
20-9920	P/S Switcher Supply

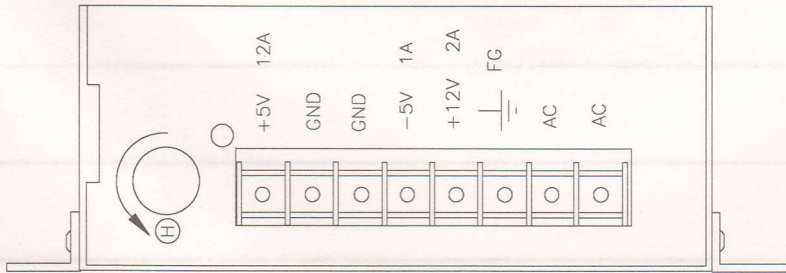
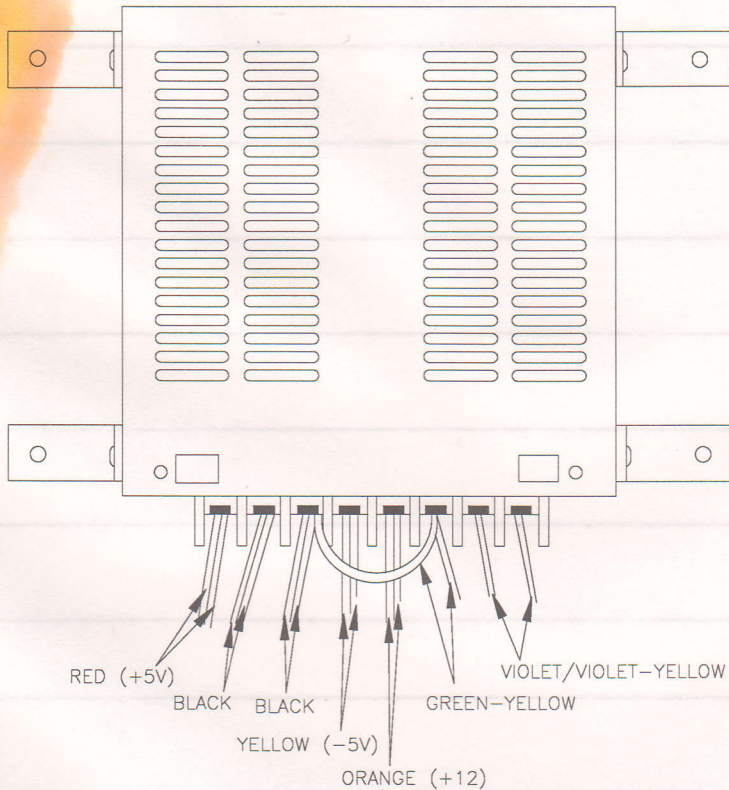





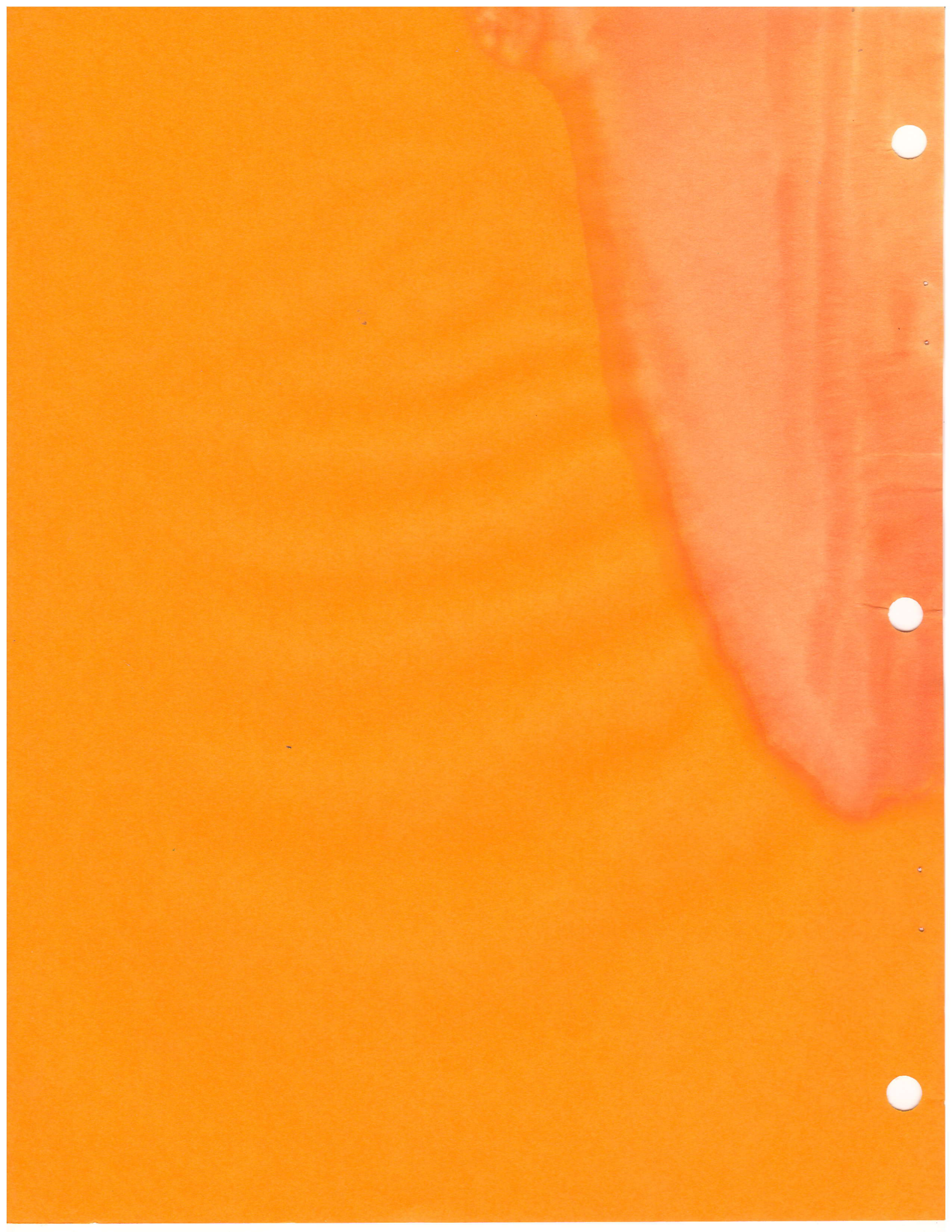

# KILLER INSTINCT

SECTION  
three

## Wiring Diagrams

FUNCTION	WIRE COLOR	PIN	PIN	WIRE
Ground	Black	A	1	Black
Ground	Black	B	2	Black
+5VDC	Red	C	3	Red
+5VDC	Red	D	4	Red
-5VDC	Red	E	5	Red
+12VDC	Red	F	6	Red
Key	Key	H	7	Key
Coin Counter 2	Brown-Red	J	8	Brown
	NC	K	9	NC
Speaker	Brown-Gray	L	10	Red-Gray
	NC	M	11	NC
Video Green	Green	N	12	Red
Video Sync	White	P	13	Brown
Speaker 1	White-Gray	R	14	Shield
	Black-Green	S	15	Black-Blue
	Black-Red	T	16	Black-Brown
Start	Violet-White	U	17	White
Up	Violet-Black	V	18	White-Black
Down	Violet-Brown	W	19	White-Brown
Left	Violet-Red	X	20	White-Red
	Violet-White	Y	21	White-White
Quick-Flash	Violet-Yellow	Z	22	White-Yellow
Medium-Flash	Violet-Green	a	23	Violet-Green
2 Flash-Flash	Violet-Blue	b	24	Violet-Blue
Not Used	Violet	c	25	Violet
	NC	d	26	NC
	NC	e	27	NC
Ground	Black	f	28	Black

### JAMMA Chart

FUNCTION	WIRE COLOR	PIN	PIN	WIRE COLOR	FUNCTION
Ground	Black	A	1	Black	Ground
Ground	Black	B	2	Black	Ground
+5VDC	Red	C	3	Red	+5VDC
+5VDC	Red	D	4	Red	+5VDC
-5VDC	Yellow	E	5	Yellow	-5VDC
+12VDC	Orange	F	6	Orange	+12VDC
	Key	H	7	Key	
Coin Counter 2	Brown-Red	J	8	Brown	Coin Counter 1
	N/C	K	9	N/C	
Speaker-	Brown-Gray	L	10	Red-Gray	Speaker+
	N/C	M	11	N/C	
Video Green	Green	N	12	Red	Video Red
Video Sync	White	P	13	Brown	Video Blue
Service Credits	White-Gray	R	14	Shield	Video Ground
Slam Tilt	Black-Green	S	15	Black-Blue	Test
Coin 2	Black-Red	T	16	Black-Brown	Coin 1
2 Start	Violet-White	U	17	White	1 Start
2 Up	Violet-Black	V	18	White-Black	1 Up
2 Down	Violet-Brown	W	19	White-Brown	1 Down
2 Left	Violet-Red	X	20	White-Red	1 Left
2 Right	Violet-Orange	Y	21	White-Orange	1 Right
2 Quick/High	Violet-Yellow	Z	22	White-Yellow	1 Quick/High
2 Medium/High	Violet-Green	a	23	White-Green	1 Medium/High
2 Fierce/High	Violet-Blue	b	24	White-Blue	1 Fierce/High
Not Used	Violet	c	25	White-Violet	Not Used
	N/C	d	26	N/C	
	N/C	e	27	N/C	
Ground	Black	f	28	Black	Ground
SOLDER SIDE			COMPONENT SIDE		

# Interboard Wiring

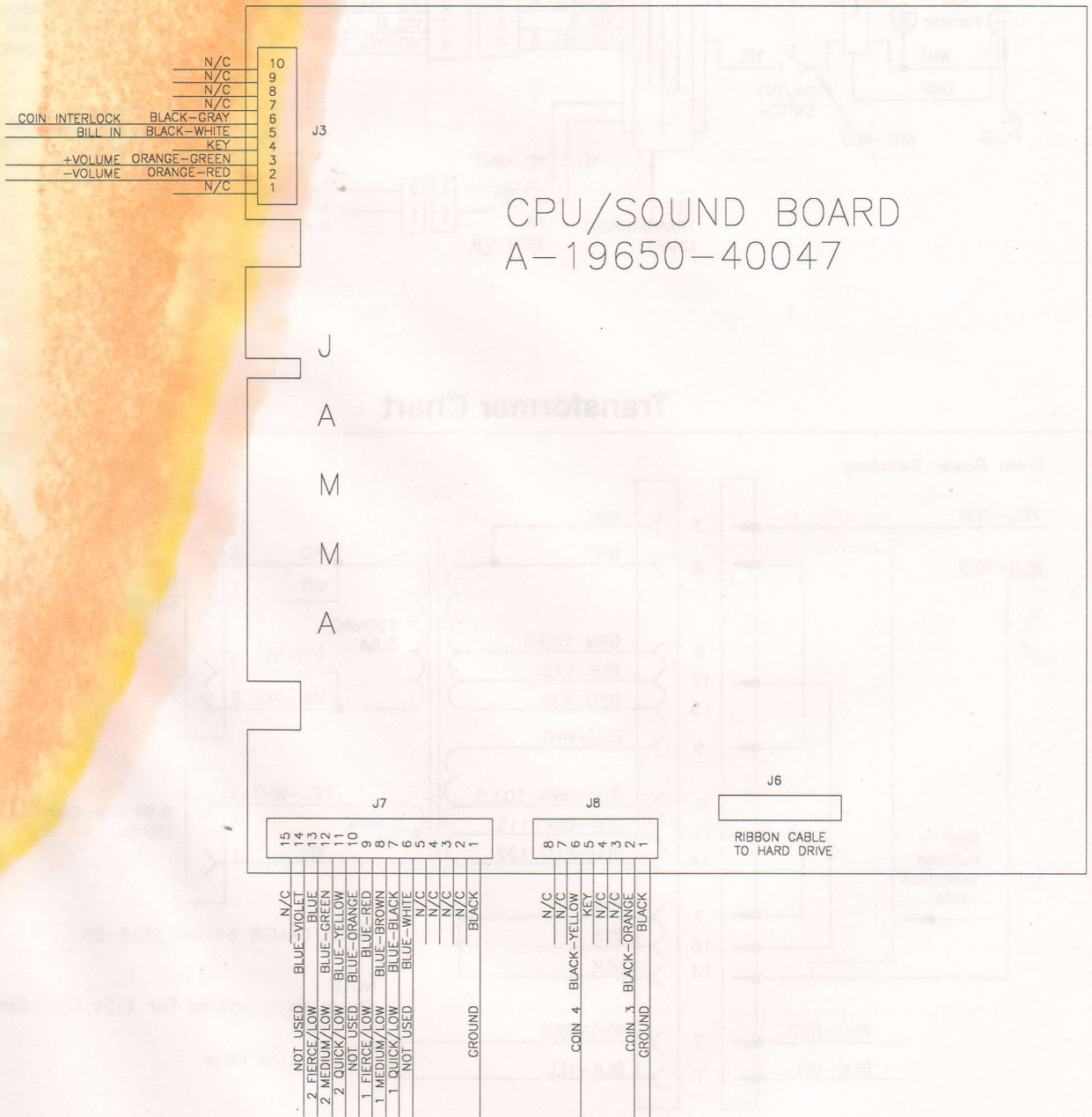

## Power Wiring

NOTE:  
For 230VAC Operation  
1. Fuse is 2A S.B.  
2. Varistor is 250V.

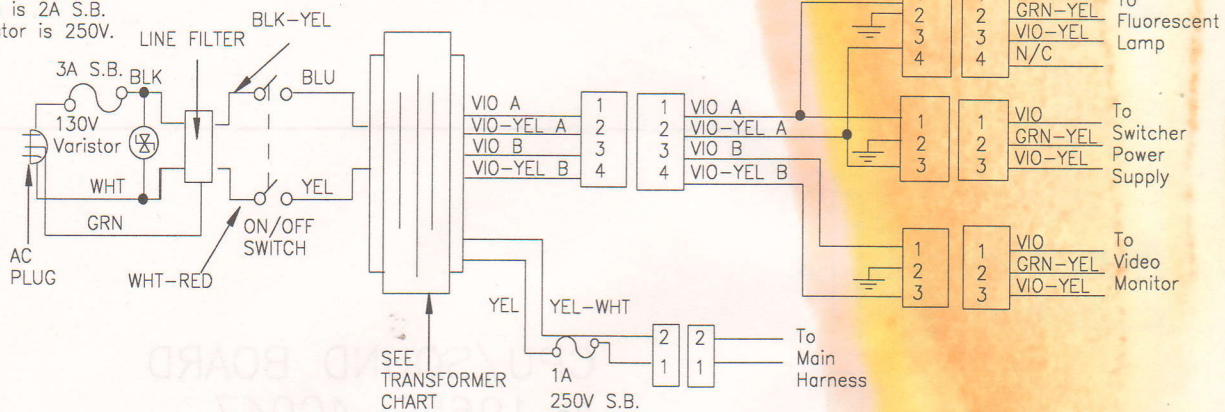

## Transformer Chart

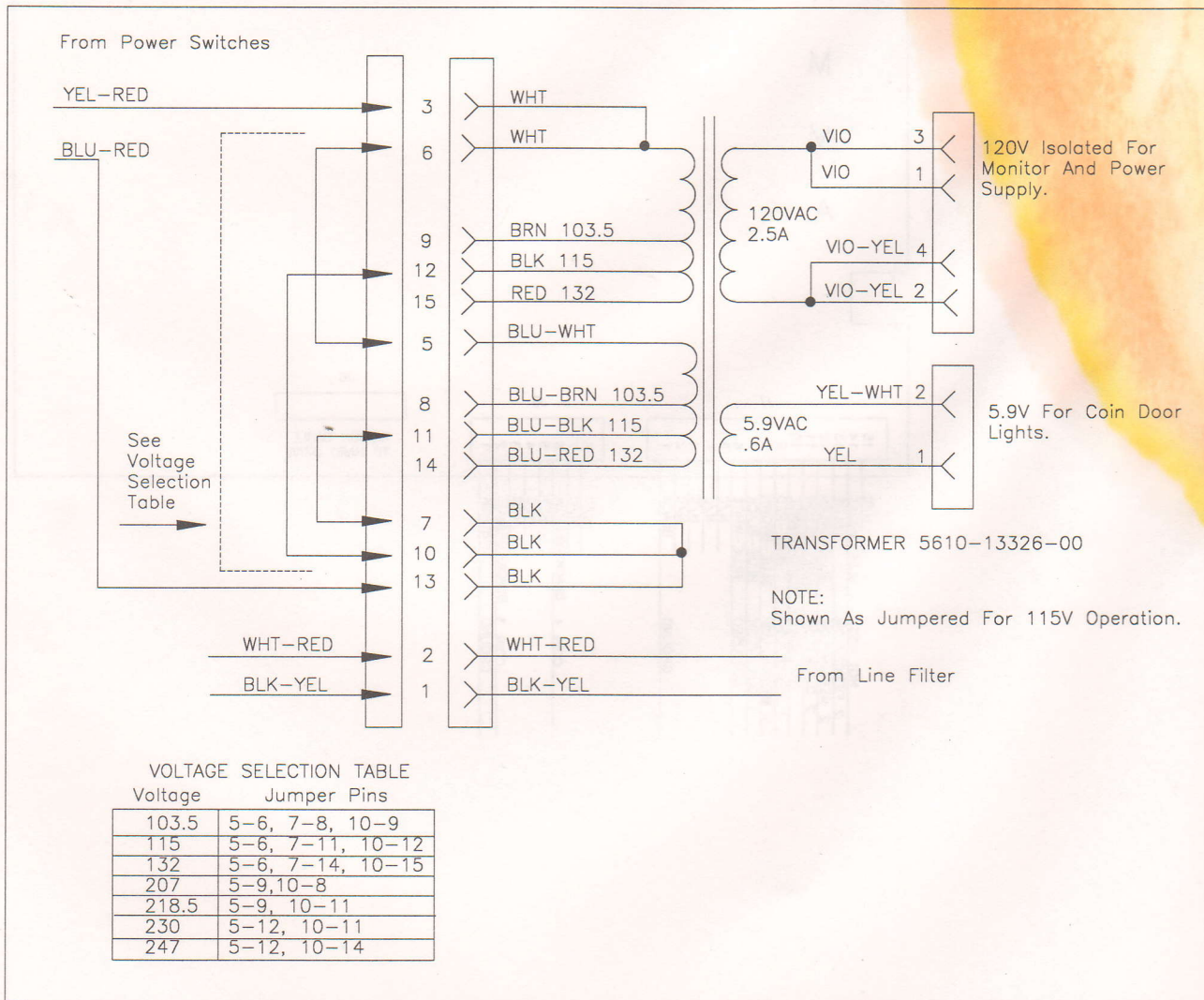

# Cabinet Wiring

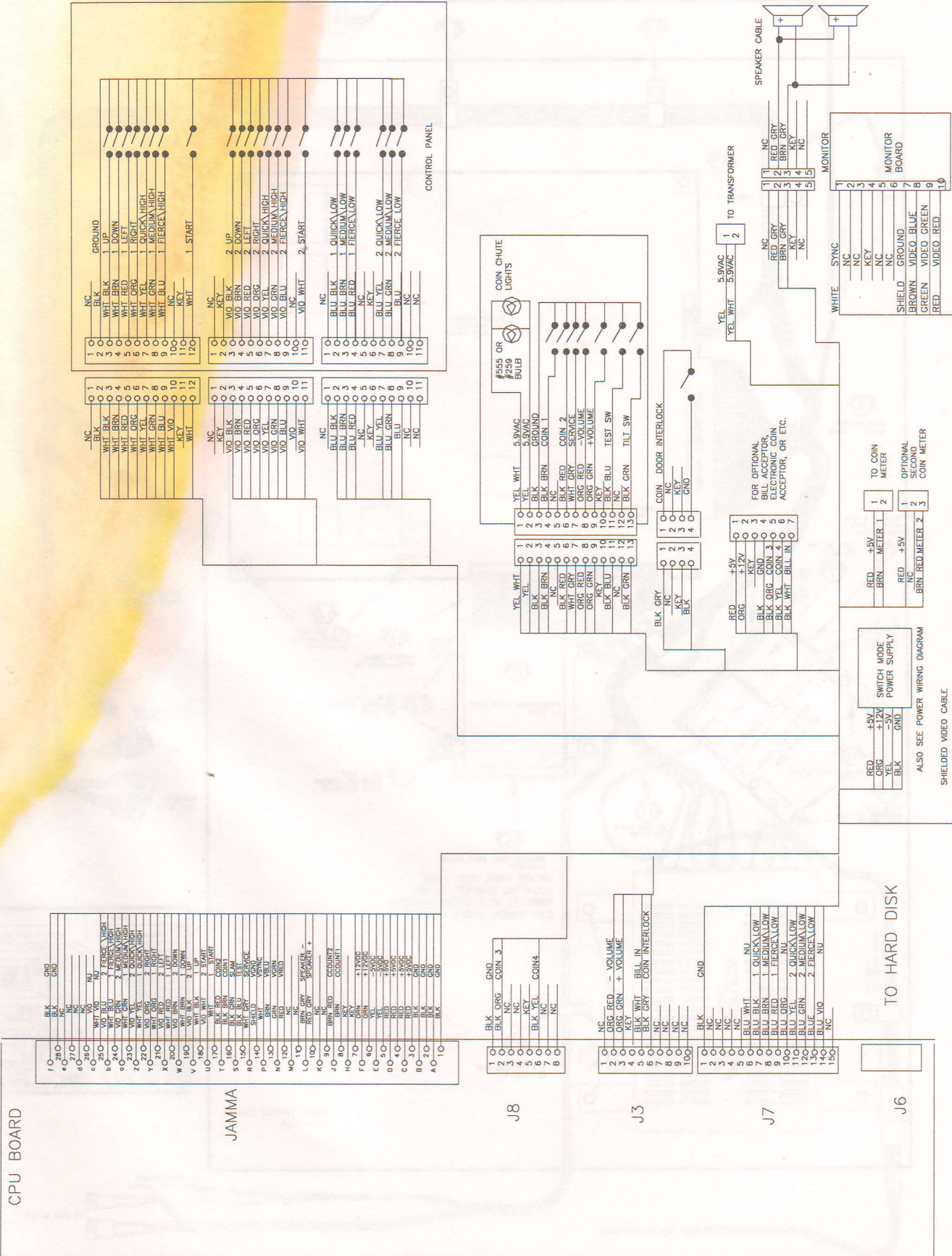

# Electronic Rack Assembly

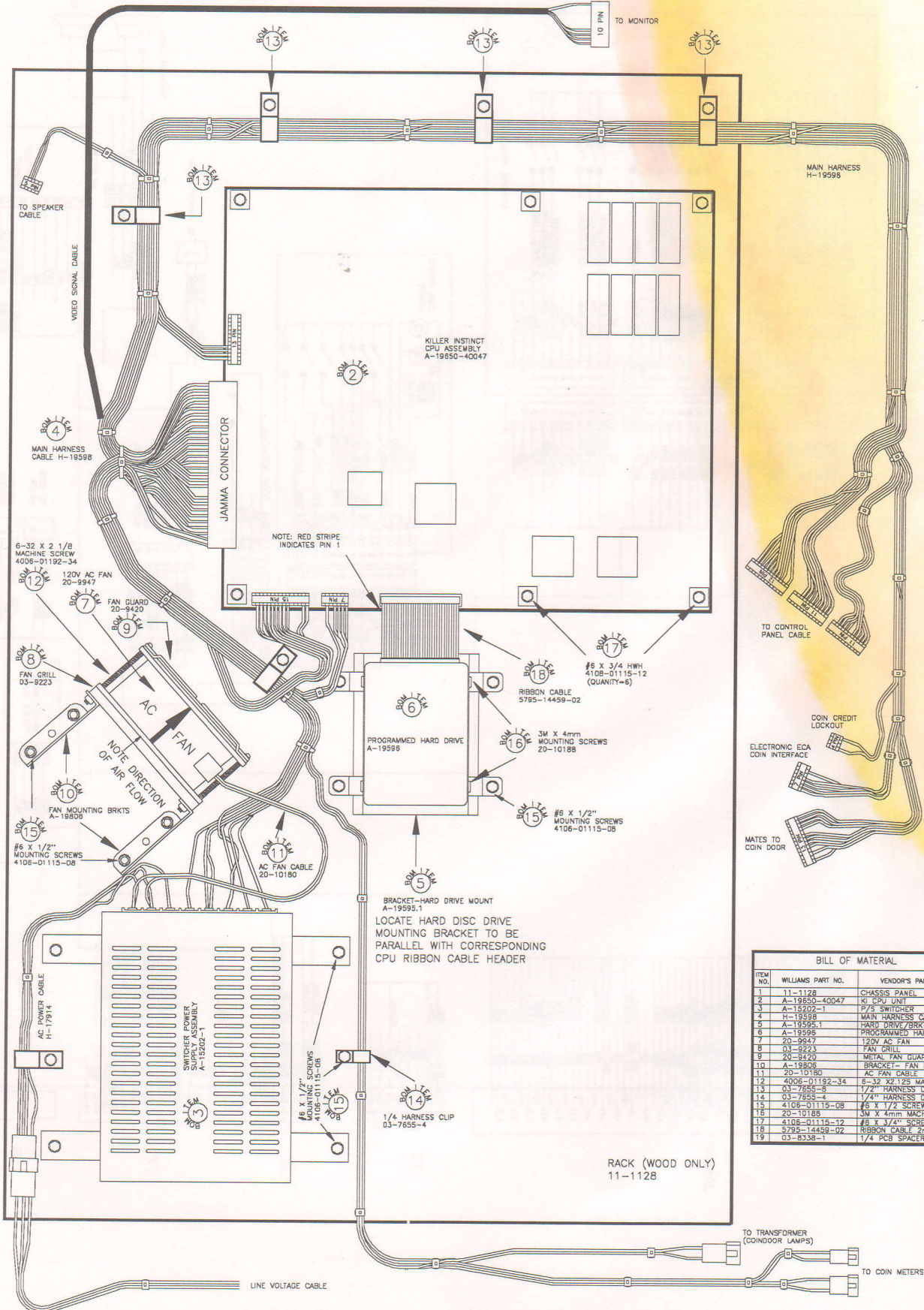

BILL OF MATERIAL		
ITEM NO.	WILLIAMS PART NO.	VENDOR'S PART NO.
1	11-1128	CHASSIS PANEL
2	A-19595-40047	KI CPU UNIT
3	A-15202-1	P/S SWITCHER
4	H-19598	MAIN HARNESS CABLE
5	A-19595-1	HARD DRIVE/BRKT ASM
6	A-19595	PROGRAMMED HARD DISK
7	20-9947	120V AC FAN
8	03-9223	FAN GRILL
9	20-9420	METAL FAN GUARD
10	A-19908	BRACKET-FAN MOUNT
11	20-10180	AC FAN CABLE
12	4008-01192-34	6-32 X2 1/25 MACH SCREW
13	03-7655-8	1/2" HARNESS CLIP
14	03-7655-4	1/4" HARNESS CLIP
15	4106-01115-08	#6 X 1/2" SCREW
16	20-10180	3M X 4mm MACH SCREW
17	4106-01115-12	#6 X 3/4" SCREW
18	5795-14459-02	RIBBON CABLE 2mm-2.125"
19	03-8338-1	1/4 PCB SPACER

NOTES

NOTES

## CONTROL PANEL WIRE COLORS

### Player One

Start	White
Up	White-Black
Down	White-Brown
Left	White-Red
Right	White-Orange
Quick/High	White-Yellow
Medium/High	White-Green
Fierce/High	White-Blue
Quick/Low	Blue-Black
Medium/Low	Blue-Brown
Fierce/Low	Blue-Red
Ground	Black

### Player Two

Start	Violet-White
Up	Violet-Black
Down	Violet-Brown
Left	Violet-Red
Right	Violet-Orange
Quick/High	Violet-Yellow
Medium/High	Violet-Green
Fierce/High	Violet-Blue
Quick/Low	Blue-Yellow
Medium/Low	Blue-Green
Fierce/Low	Blue
Ground	Black

## FUSES

**Line Fuse** - (Domestic) 3A. S.B., 125V  
(Foreign) 2A. S.B., 250V

**General Illumination** - (Domestic & Foreign) 1A. S.B., 250V

## WARNING & NOTICES

### WARNING

USE OF NON-MIDWAY PARTS OR CIRCUIT MODIFICATIONS MAY CAUSE SERIOUS INJURY OR EQUIPMENT DAMAGE! USE ONLY MIDWAY AUTHORIZED PARTS.

\* For safety and reliability, substitute parts and modifications are not recommended.

\* Substitute parts or modifications may void FCC type acceptance.

\* This game is protected by federal copyright, trademark and patent laws. Unauthorized modifications may be illegal under federal law. This also applies to MIDWAY logos, designs, publications and assemblies. Moreover, facsimiles of MIDWAY equipment (or any feature thereof) may be illegal under federal law, regardless of whether or not such facsimiles are manufactured with MIDWAY components.

### WARNING

**NOTE:** This equipment has been tested and found to comply with the limits for a Class A digital device, pursuant to Part 15 of the FCC Rules. These limits are designed to provide reasonable protection against harmful interference when the equipment is operated in a commercial environment. This equipment generated, uses and can radiate radio frequency energy and if not installed and used in accordance with the instruction manual, may cause harmful interference to radio communications. Operation of this equipment in a residential area is likely to cause harmful interference in which case the user will be required to correct the interference at his own expense.

### WARNING

Prevent shock hazard and assure proper game operation. Only plug this game into a properly grounded outlet. Do not use a cheater plug to defeat the power cord's grounding pin. Do not cut off the ground pin.

### NOTICE

**When MIDWAY ships a game, it is in compliance with FCC regulations. Your sticker is proof. If the sticker is missing or damaged, legal repercussions to the owner or distributor of the game may result. If your game does contain an FCC sticker, call MIDWAY immediately.**

### NOTICE

No part of this publication may be reproduced by any mechanical, photographic, or electronic process, or in the form of a phonographic recording, nor may be transmitted, or otherwise copied for public or private use, without permission from the publisher.

**FOR SERVICE: CALL YOUR AUTHORIZED MIDWAY DISTRIBUTOR.**

**Killer Instinct™**

© 1994 Nintendo/Rare

Game by Rare

Killer Instinct is a trademark of Nintendo

Manufactured and sold by Midway Manufacturing Company under license

MIDWAY MANUFACTURING COMPANY  
3401 N. CALIFORNIA AVE.  
CHICAGO, IL 60618