

# LeMans™

Operation, Maintenance,  
Service Manual



## WARRANTY

Seller warrants that its printed circuit boards and parts thereon are free from defects in material and workmanship under normal use and service for a period of ninety (90) days from date of shipment. Seller warrants that its television monitors are free from defects in material and workmanship under normal use and service for a period of thirty (30) days from date of shipment. None of the Seller's other products or parts thereof are warranted.

If the products described in this manual fail to conform to this warranty, Sellers' sole liability shall be, at its option, to repair, replace, or credit Buyer's account for such products which are returned to Seller during said warranty period, provided:

- (a) Seller is promptly notified in writing upon discovery by Buyer that said products are defective;
- (b) Such products are returned prepaid to Sellers' plant; and
- (c) Seller's examination of said products discloses to Seller's satisfaction that such alleged defects existed and were not caused by accident, misuse, neglect, alteration, improper repair, installation or improper testing.

In no event shall Seller be liable for loss of profits, loss of use, incidental or consequential damages.

EXCEPT FOR ANY EXPRESS WARRANTY SET FORTH IN A WRITTEN CONTRACT BETWEEN SELLER AND BUYER WHICH CONTRACT SUPERSEDES THE TERMS OF THIS ORDER, THIS WARRANTY IS EXPRESSED IN LIEU OF ALL OTHER WARRANTIES EXPRESSED OR IMPLIED, INCLUDING THE IMPLIED WARRANTIES OF MERCHANTABILITY AND FITNESS FOR A PARTICULAR PURPOSE, AND OF ALL OTHER OBLIGATIONS OR LIABILITIES ON THE SELLER'S PART, AND IT NEITHER ASSUMES NOR AUTHORIZES ANY OTHER PERSON TO ASSUME FOR THE SELLER ANY OTHER LIABILITIES IN CONNECTION WITH THE SALE OF PRODUCTS UNDER THIS ORDER.

This document is and contains confidential trade secret information of Atari, Inc.

This document is loaned under confidential custody for the sole purpose of operation, maintenance or repair of Atari equipment and may not be used by or disclosed to any person for any other purpose whatever, and remains the property of Atari, Inc.

Neither it nor the information it contains may be reproduced, used, or disclosed to persons not having a need to know consistent with the purpose of the loan, without written consent of Atari, Inc.

# LeMans™

## Operation, Maintenance and Service Manual

ATARI INC.  
14600 WINCHESTER BLVD  
LOS GATOS, CA 95030  
408/374-2440 • TELEX 357-488

By the Publications Group, Engineering Department



All rights reserved. Copyright © 1976 by Atari, Inc.

No part of this publication may be reproduced by any mechanical, photographic, or electronic process, or in the form of a phonographic recording, nor may it be stored in a retrieval system, transmitted, or otherwise copied for public or private use, without permission from the publisher.

**For permission requests, write:**

**Atari, Inc.  
Engineering Dept.  
Publications Group  
14600 Winchester Blvd.  
Los Gatos, Calif. 95030**

Lithographed in the U.S.A.

# Table of Contents

<b>I. GENERAL MAINTENANCE AND SERVICE</b> .....	<b>1</b>
1.1 <i>Introduction and Warranty Information</i> .....	1
1.2 <i>Access and Basic Construction</i> .....	1
1.3 <i>New Machine Set-Up and Checkout Procedures</i> .....	1
1.4 <i>Game Sequence</i> .....	2
1.5 <i>Antenna Wire and Anti-Static Modification</i> .....	2
1.6 <i>TV and Lighting: Service Procedures</i> .....	3
1.6.1 <i>General Illumination Lamps</i>	
1.6.2 <i>Plexiglas Screen</i>	
1.6.3 <i>Bezel</i>	
1.6.4 <i>TV Monitor Removal</i>	
1.6.5 <i>TV Monitor Adjustment</i>	
1.7 <i>Coin Door: Service Procedures</i> .....	4
1.7.1 <i>Door Lock</i>	
1.7.2 <i>Reject Linkage</i>	
1.7.3 <i>Coin Micro Switches</i>	
1.7.4 <i>Coin Acceptors</i>	
1.7.5 <i>Acceptor Adjustment</i>	
1.7.6 <i>Acceptor Maintenance</i>	
1.8 <i>Electronics Tray Subassemblies: Service Procedures</i> .....	5
1.8.1 <i>Fuse Replacement</i>	
1.8.2 <i>Transformer Replacement</i>	
1.8.3 <i>Interlock Switches</i>	
1.8.4 <i>Printed Circuit Board</i>	
1.8.5 <i>PCB Adjustments</i>	
1.9 <i>Mechanical Controls: Service Procedures</i> .....	6
1.9.1 <i>Control Panel</i>	
1.9.2 <i>Gear Shifter Assembly</i>	
1.9.3 <i>Pedal Assembly</i>	
1.9.4 <i>Steering Wheel Assembly</i>	
1.10 <i>Regular Machine Maintenance</i> .....	6
1.11 <i>Troubleshooting Procedures</i> .....	6
1.11.1 <i>TV Monitor</i>	
1.11.2 <i>Printed Circuit Board</i>	
1.11.3 <i>Wiring Harness</i>	
1.11.4 <i>General Suggestions</i>	

# Table of Contents

- 1.11.5 TV Monitor Troubleshooting
- 1.11.6 Steering Assembly
- 1.11.7 Troubleshooting by Symptom

<b>II. PRINTED CIRCUIT BOARD: THEORY OF OPERATION AND SERVICING ...</b>	<b>9</b>
2.1 Introduction .....	9
2.2 Power Supply and Buffered Start .....	10
2.3 Oscillator .....	12
2.4 Electronic Latch .....	12
2.5 Credit and Start Circuit .....	13
2.6 Synchronization and Blanking .....	16
2.7 Sound Circuitry .....	19
2.7.1 Screech Sound	
2.7.2 Crash Sound	
2.7.3 Engine Sound	
2.8 Audio Amplifier .....	20
2.9 Dynamics and Speed Control .....	20
2.9.1 Gas (Speed) Circuit	
2.9.2 Brake Circuit	
2.9.3 Speed Oscillator	
2.10 VLdl Signal .....	27
2.11 1 STOP Signal .....	28
2.12 LdlB Signal .....	29
2.13 RESET 1 Signal .....	29
2.14 Steering Control .....	29
2.15 Steering Encoder .....	31
2.16 Crash and Playtime .....	31
2.17 Track Selection .....	33
2.18 Memory Circuit .....	33

# Table of Contents

2.19	<i>Window Concept</i>	35
2.20	<i>Introduction to Motion</i>	37
2.21	<i>Horizontal Count</i>	38
2.22	<i>Vertical Car Motion</i>	38
2.23	<i>Horizontal Car Motion</i>	39
2.24	<i>Car Display</i>	40
2.25	<i>Race Track Display</i>	40
2.26	<i>Time and Score Storage</i>	41
<b>III.</b>	<b>SCHEMATICS, DRAWINGS AND PARTS LISTS</b>	<b>45</b>

Table of Contents

Chapter 1	1
Chapter 2	15
Chapter 3	30
Chapter 4	45
Chapter 5	60
Chapter 6	75
Chapter 7	90
Chapter 8	105
Chapter 9	120
Chapter 10	135
Chapter 11	150
Chapter 12	165
Chapter 13	180
Chapter 14	195
Chapter 15	210
Chapter 16	225
Chapter 17	240
Chapter 18	255
Chapter 19	270
Chapter 20	285
Chapter 21	300
Chapter 22	315
Chapter 23	330
Chapter 24	345
Chapter 25	360
Chapter 26	375
Chapter 27	390
Chapter 28	405
Chapter 29	420
Chapter 30	435
Chapter 31	450
Chapter 32	465
Chapter 33	480
Chapter 34	495
Chapter 35	510
Chapter 36	525
Chapter 37	540
Chapter 38	555
Chapter 39	570
Chapter 40	585
Chapter 41	600
Chapter 42	615
Chapter 43	630
Chapter 44	645
Chapter 45	660
Chapter 46	675
Chapter 47	690
Chapter 48	705
Chapter 49	720
Chapter 50	735
Chapter 51	750
Chapter 52	765
Chapter 53	780
Chapter 54	795
Chapter 55	810
Chapter 56	825
Chapter 57	840
Chapter 58	855
Chapter 59	870
Chapter 60	885
Chapter 61	900
Chapter 62	915
Chapter 63	930
Chapter 64	945
Chapter 65	960
Chapter 66	975
Chapter 67	990
Chapter 68	1005
Chapter 69	1020
Chapter 70	1035
Chapter 71	1050
Chapter 72	1065
Chapter 73	1080
Chapter 74	1095
Chapter 75	1110
Chapter 76	1125
Chapter 77	1140
Chapter 78	1155
Chapter 79	1170
Chapter 80	1185
Chapter 81	1200
Chapter 82	1215
Chapter 83	1230
Chapter 84	1245
Chapter 85	1260
Chapter 86	1275
Chapter 87	1290
Chapter 88	1305
Chapter 89	1320
Chapter 90	1335
Chapter 91	1350
Chapter 92	1365
Chapter 93	1380
Chapter 94	1395
Chapter 95	1410
Chapter 96	1425
Chapter 97	1440
Chapter 98	1455
Chapter 99	1470
Chapter 100	1485

# I. GENERAL MAINTENANCE AND SERVICE

## 1.1 INTRODUCTION AND WARRANTY INFORMATION

Le Mans is a race car video game. It simulates the experience of driving a high speed race car around constantly changing race tracks. All the machine controls (steering, gear shift, accelerator and brakes) behave like those of a real car.

The electronics of this game are solid state for long life and low maintenance. The mechanical assemblies (steering, gear shifter and pedals) have been modularly designed for easy removal and servicing.

However, as with all mechanical or electrical devices, there may be minor problems. *If the printed circuit board computer (PCB) fails within the warranty period, contact the distributor from whom the game was originally purchased for repair or replacement instructions.*

*Any PCB repair attempted by anyone other than authorized Atari Service Center personnel will void the PCB warranty.*

For the Atari warranty on the Le Mans game, please see the inside front cover of this manual.

## 1.2 ACCESS AND BASIC CONSTRUCTION

Three openings: Coin door, rear door and a removable front control panel—provide convenient access to all sub-assemblies and adjustment points. Opening the coin door exposes all the coin handling equipment—the coin acceptors and rejector linkages, the coin counter and the coin box. The rear door is used to service the TV monitor, the PCB in the RF-shielded box, and the components mounted to the electronics tray—the transformers, fuses, etc.

A pair of interlock switches is mounted to the electronics tray and turns off the entire machine when the rear door is opened. Each switch in the pair shuts off a "hot" lead in the AC line. *The interlock switches protect the operator from accidental shock, so they must always be kept in perfect working order.* If you need to test or adjust the machine with the rear door open, place the interlock

switches in the closed or "on" position by pulling out the white actuator shaft.

All the major sub-assemblies have been designed modularly for easy servicing or replacement. The control panel, the pedal assembly, the PCB and the TV monitor can each be removed after the wiring and the release bolts have been removed.

## 1.3 NEW MACHINE SET-UP AND CHECK-OUT PROCEDURES

*Before turning this machine on, inspect it carefully for any damage which may have occurred during shipping.*

As each new Le Mans leaves the factory, every component and sub-assembly is carefully checked for proper operation and adjustment. However, since parts may have been damaged or adjustments changed during shipping, the following checkout procedure must be repeated prior to placing the machine on location.

1. With the machine unplugged, open both access doors and carefully inspect both the exterior and interior of the machine for any obvious shipping damage to the cabinet or internal components and sub-assemblies. If any such damage is discovered, contact the carrier and Atari, Inc. immediately. Then contact the distributor from whom the game was originally purchased for repair or replacement instructions.
2. Inspect the interior of the machine more carefully looking for broken or disconnected wires, sub-assemblies pulling loose or not firmly mounted and any foreign objects shorting electrical connections. Pay particular attention to the connections to the TV monitor, the control panel and the coin door. Also make sure that the PCB edge connector and the fuse are firmly seated.
3. Plug in the machine and if the rear door panel is off, defeat the interlock switch by pulling out the white actuator shaft. At this point the CRT (cathode ray tube) should display the race track and the score after a short warm up time. Examine the CRT picture. It should be steady, sharp and exhibit the proper levels of brightness and contrast.

4. Insert several old *and* new coins into each coin acceptor. No genuine coin should be rejected. Pressing the game credit switch (start switch) advances the coin counter one digit. Operate both coin rejector handles and check for any signs of binding or sticking. Finally, check to see that both acceptors are firmly mounted in their frames.

#### NOTE

*Do not spray coin acceptors and rejector linkages with any lubricant or other substance, since they may attract dust and become gummed up. Simply submerge the parts in boiling water and let air dry.*

5. Start a game by pressing the start switch button and check for proper game sequence making sure all aspects of the game (steering, gear shifter, accelerator, brakes, score, timer and changing track display) are functioning correctly. If you are not familiar with the game sequence for Le Mans, read the game sequence analysis.
6. Adjusting play time modifies crash mode. The play time is pre-set at the factory for approximately 1 minute 40 seconds, and should not be changed.
7. Both doors (rear and cash) should open and close without binding, and both door locks should turn to the "locked" and "unlocked" positions freely.
8. Check the rear door interlock switch to see that it turns off the machine when the door is opened.

### 1.4 GAME SEQUENCE

With the game plugged in and the rear door installed, the CRT will display the *attract* mode. The attract mode for Le Mans displays the changing race courses, a stationary race car positioned where the last player ended, plus the score of the previous game and the game timer (which should read 0). At this point, the *play* mode starts: the score is reset to 0, the timer begins counting down from 78 by twos, the car engine begins idling and is ready to be driven.

The controls of the machine and the movement of the car image simulate those of a real car. Once accelerated, the car becomes increasingly difficult to stop the faster the car is moving.

Turning the steering wheel causes the car to turn in the direction of rotation. The car will turn only while the steering wheel is being rotated.

The gear shifter works exactly like that of a real car. After a crash, shift into first, rotate the steering

wheel to turn the car so it will continue in the proper direction and step on the accelerator pedal. Once the engine has revved to its limit, shift into second; when the engine has revved to its limit, shift into third and then fourth. The speed of the car will climb as you shift through the gears. Keep in mind, though, that the engine will "bog down" if you shift up too fast or start out in the wrong gear (2nd or 3rd).

Both the accelerator and brakes have only two positions: on or off. When the accelerator is depressed, the engine will rev up. Stepping on the brake pedal will bring the car to a screeching halt and if the steering wheel is turned as the brakes are applied, the car will skid realistically.

Points are scored only by passing the course check points in the proper sequence as indicated by the arrows on the CRT. The score is displayed at the top next to the game timer.

If the car is driven into any of the pylons, a crash will result. The crash is accompanied by a crash sound, uncontrolled spinning of the car during which time the car cannot be driven. As soon as the crash sound has ended, shift into first and continue driving the car in the proper direction. The game continues in this fashion until the game timer reaches 0 at which point the controls become "dead" and the machine is reset to the attract mode.

Players are given an indication of their skill by matching their score (points) against the "rating card" located on the game. This rating system is based on a game playtime of approximately one minute and forty seconds (as adjusted prior to shipment). If game playtime is readjusted by the operator, this point/rating system is no longer valid.

### 1.5 ANTENNA WIRE AND ANTI-STATIC MODIFICATION

An *electronic latch* circuit has been incorporated in the Le Mans PCB. One function of this circuit is to turn off or prevent game credit if a player tries to obtain free games by inducing a static charge in the machine. The *antenna wire* is an integral part of this system.

When a static discharge occurs, an electric current is induced in the antenna wire. This impulse is transmitted through the antenna wire to the electronic latch circuit which turns off game credit and resets the computer to the attract mode.

The antenna wire is a length of wire approximately 12 inches long. One end of the antenna is connected to pin K of the PCB edge connector and the other end has been intentionally left not connected.

The length of the antenna wire has been pre-adjusted by the factory to the overall optimum length, however some environments may require more or less critical adjustment.

*Lengthening the antenna wire increases the sensitivity of the circuit; cutting the wire shorter decreases the sensitivity.*

If players are obtaining free games by including static charges in the machine, lengthen the antenna wire (add a piece of wire) by a few inches so that a lesser charge will turn off game credit. If you have problems with static charges accidentally turning off game credit during the progress of a legitimate game, try cutting the antenna shorter in increments of 1-2 inches. Try to cut only the minimum amount off the antenna, otherwise players may be able to obtain free games.

The anti-static modification may be tested during a game by touching the end of the antenna wire with your finger as the body usually has enough capacitance to actuate the electronic latch. If the game is shut off, the circuit is functioning correctly.

## 1.6 TV AND LIGHTING: SERVICE PROCEDURES

Use the following procedures to replace the general illumination lamps, the plexiglass screen and bezel and to service the TV monitor.

### 1.6.1 General Illumination Lamps:

A fluorescent 18-inch fixture is mounted behind the plexiglas screen to illuminate the Le Mans display panel. To replace the burned-out tubes, reach in the rear door and unscrew the four lamp PC board mounting screws; unplug the two wires that are attached to it at plugs near the upper left inside area of the cabinet. Remove the panel and replace burned-out lamps with the same size and type of tube. The two small bulbs for signalling extended play are type-GE47 lamps.

### 1.6.2 Plexiglas Screen:

Use the above procedure to remove the lamps PCB. Then remove the three wing nuts and carriage bolts that hold down the upper aluminum plexiglas screen retainer. Lift out the plexiglas.

### 1.6.3 Bezel:

Use the above two procedures to remove the plexiglas; the bezel will simply lift out.

### 1.6.4 TV Monitor Removal:

To remove the entire TV monitor assembly, remove the four Phillips-head bolts and nuts found on the top of the monitor frame. *Do not remove the aluminum angle brace at the bottom edge.* Disconnect the electrical connector to the TV, and lift out the monitor very carefully. **DISCHARGE THE SECOND ANODE BEFORE SERVICING.**

### 1.6.5 TV Monitor Adjustment:

The TV monitor and its adjustment controls function like any normal TV set with the exception of the sound which is adjusted on the PCB. The monitor is serviced through the rear door of the machine.

(a) *Brightness:* Adjust the brightness *before* the contrast. Adjust so that the CRT background is as *dark as possible*.

(b) *Contrast:* The contrast is adjusted so that the CRT images are *as bright as possible* against the pre-adjusted dark background *without being blurred*.

(c) *Vertical Hold:* Adjust only if the picture appears to be rolling up or down the screen. Adjust for a stable centered picture.

(d) *Horizontal Hold:* Adjust if the picture is slightly off center horizontally, if the images appear warped or if the picture is broken into a series of diagonal lines.

(e) *Vertical Size:* Adjust only if the top and bottom of the race course is cut off from the screen or if there is too much distance between the edge of the course and the edge of the screen, which will appear as an extra set of horizontal dotted lines on the top and bottom of the CRT display. Adjust for maximum picture size.

(f) *Vertical Linearity:* Change this adjustment only if the top of the picture seems compressed.

(g) *The Yoke:* The yoke should never need adjustment unless the adjuster have been tampered with or the machine damaged. If yoke adjustment is indicated, adjust both yoke rings *simultaneously* for optimum centering of the race course on the CRT.

(h) *The A.C. Voltage Switch:* Set this switch to the 115 Volt position ("115" visible on the switch) if the machine is connected to a 115 volt source. *The TV monitor will not function if this switch is misadjusted.*

(i) *The TV Monitor Fuses:* Two 6/10 Amp, 125 volt Slo-Blo fuses (313 3AG) protect the TV monitor from electrical overload. Replace blown fuses *only* with those which have the above rating.

**NOTE**

*The TV is not fused by the fuse on the electronics tray.*

## 1.7 COIN DOOR: SERVICE PROCEDURES

All coin handling equipment is accessible through the front door. To collect the coins, open the door, remove the coin box and record the meter reading.

The Le Mans is equipped with two coin acceptor assemblies so the entire machine will not be out of service if one acceptor is malfunctioning.

Please keep in mind that proper adjustment and lubrication of the coin handling equipment will help minimize your service calls.

### 1.7.1 Door Lock:

The lock cylinder can be withdrawn and replaced after the rear retaining nut and the lock cam are removed. If the coin door does not fit tightly or the lock does not turn freely, try bending the lock cam slightly with a pair of pliers.

**NOTE**

*The lock cylinder should be lubricated once every three months or so with graphite or WD-40®.*

### 1.7.2 Reject Linkage:

A separate reject button operates the wiper lever of each coin acceptor. When this button is pushed in, the wiper lever of the coin acceptor is operated which should dislodge any coins "stuck" in the acceptor. The rejector button cannot be removed.

**NOTE**

*Lubricate the rejector linkage with silicone grease when you receive the machine and thereafter at approximately six month intervals.*

### 1.7.3 Coin Micro Switches:

To remove a malfunctioning micro switch, unscrew the two retaining screws, record the wire positions and pull off the slip-on connectors.

### 1.7.4 Coin Acceptors:

The coin acceptor can be removed for servicing after the retaining screw has been removed.

### 1.7.5 Acceptor Adjustment:

All coin acceptors leave the factory adjusted for maximum performance. However, if more critical adjustments are necessary or if the unit has been completely disassembled for service, the following adjustment procedure is suggested:

(These tests and adjustments are performed with the acceptor in a vertical position on a level surface in the rest position.)

#### (a) Kicker and Separator

1. Set the unit with the back of the acceptor facing you in the test position.
2. Loosen the screws holding the kicker and the separator and move both the kicker and the separator as far to the right as they will go. Tighten the screws.
3. Insert several test coins (both old and new) and note that some are returned by striking the separator.
4. Loosen the separator screw and move the separator a slight amount to the left. Tighten the screw.
5. Insert the test coins again and, if some of them are still returned, repeat Step #4 until all the coins are accepted.
6. Loosen the kicker screw and move the kicker as far to the left as it will go. Tighten the screw.
7. Insert the test coins and note that some are returned.
8. Loosen the kicker screw and move the kicker a slight amount to the right.
9. Insert the test coins again and, if some are still returned, repeat Step #8 until all the coins are accepted.
10. Be sure that both screws are tight after the adjustments have been made.

(b) *The Magnet Gate*

1. Set the acceptor with the front of the unit facing you in the test position.
2. Turn the magnet gate adjusting screw out (counterclockwise) until none of the coins will fit through.
3. With a coin resting in the coin entrance of the acceptor, turn the adjuster in (clockwise) until the coin barely passes through the magnet gate.
4. Test this adjustment using several other coins (both old and new) and, if any of them fail to pass through the magnet gate, repeat Step #3 until all of the coins are accepted.
5. Fix the magnet gate adjusting screw in this position by tightening down the magnet gate screw lock nut.

**1.7.6 Acceptor Maintenance:**

Depending on the environment in which the acceptor is used, periodic preventative maintenance should be performed.

The mainplate may be cleaned with any non-abrasive household cleaner. Rinse and dry thoroughly to remove deposits and film.

Remove all metal particles from the magnet by guiding the point of a screwdriver along the edges of the magnet.

Remove the transfer cradle and clean the bushing and pivot pin. A pipe cleaner is an effective cleaning tool. Apply powdered graphite or pencil lead to the pin and bushing and reassemble.

Spray the entire unit lightly with WD-40® or a silicone lubricant.

**1.8 ELECTRONICS TRAY SUBASSEMBLIES: SERVICE PROCEDURES**

*(Pull out the power cord while performing procedures 1-4.)*

**1.8.1 Fuse Replacement:**

Replace the bad fuse with a Slo-Blo fuse rated at same amperage, 125 volts (313 3AG).

**1.8.2 Transformer Replacement:**

To remove a malfunctioning transformer remove the AC protective cover, record all wire colors and their positions, unsolder the wiring and unscrew the retaining screws.

**NOTE**

*When installing the new transformer, be sure to reconnect the chassis ground wire (lugs fastened with wood screws that mount the transformers to the wood electronics tray).*

**1.8.3 Interlock Switches:**

To remove the switches, pull off each push-on connector, squeeze in side tabs on the switch and push it through the mounting bracket.

**1.8.4 Printed Circuit Board:**

To remove the PCB from the RF-shielded box, pull the board straight out.

**CAUTION**

*PCBs are extremely fragile and require very careful handling.*

**1.8.5 PCB Adjustments:**

(a) *Volume:* This adjustment is made by a small blue trim pot marked "volume" near PCB position B9. Adjust the volume to the preference of the location but keep in mind that the machine may sound louder with the door off.

(b) *Play Time:* This is factory adjusted for the optimum time. In the case of repair or accidental misadjustment, the play time is adjusted as follows: turn the pot near position B8 *clockwise* (while facing the engraved arrow) to *lengthen* game time. This pot controls both the total game length and the crash time period. The play time counter (to the right of the lap score in the pit area) always begins counting down from 78 by twos. Adjusting the play time pot causes the game counter to count down slower or faster.

**NOTE**

*Adjusting for a longer game will also increase the length of the crash time, and affect score interpretation per the "rating card" posted on front of the CRT. Ninety seconds is the optimum adjustment. Shorter or longer play times will result in decreased revenue.*

(c) *Extended Play Switch Adjustment:* The extended play time high score rollover is operator-selectable at scores of 46, 50, 56, 60, 66, 70 or 76. See Region B2 on sheet 1 of the schematic for exact

switch settings (the DIP switch is near location N1 on the printed circuit board). To disable extended play, place all switches *off*. Only *one* switch of the seven should be enabled at a time.

## 1.9 MECHANICAL CONTROLS: SERVICE PROCEDURES

### 1.9.1 Control Panel:

To service the rear of the control panel, reach through the coin door and remove the four wing nuts behind the panel. The control panel can then be lifted out and away.

### 1.9.2 Gear Shifter Assembly:

To remove gear shifter from the control panel, first open the control panel as per procedure #1. Then record the wire colors and their positions for later reference and pull off all the slip-on connectors to the shift switches. Shift assembly can be withdrawn through the front of the control panel after the four retaining screws have been removed.

To open the gear shifter assembly, remove the four machine screws while holding the housing halves together with your fingers. Split the housing halves carefully so internal parts will not spring out and become lost. With the housing halves separated, the gearshift rod, spring, ball, detent and switch actuators will all be accessible.

#### NOTE

*When re-assembling the unit, lubricate the ball with a small amount of silicone grease, and be sure that you replace the housing screws the same way they came out.*

### 1.9.3 Pedal Assembly:

The pedal assembly must be removed to replace the brake and accelerator switches. Reach in the rear door and remove three wing nuts. From the front of the machine, grasp the protruding lip of the pedal assembly and pull out the entire unit.

To replace pedals, remove the four pedal retaining screws and lift off pedal. To replace switches, reach through the bottom of the pedal box and remove the wires and the two screws. Be sure to record all wire colors and positions before removing them from the switches.

### 1.9.4 Steering Wheel Assembly:

To service or remove steering wheel assembly, open the control panel as per procedure #1. To re-

place the wheel, remove the shaft end nut. Lift off the slotted tack ring and withdraw the steering wheel through the front of the control panel. If only the wheel needs replacement, remove the cap and the shaft. The cap will lift off when retaining screws are removed, and the shaft can be disassembled when retaining nut is removed.

#### NOTE

*When reassembling the unit, lubricate the bearings with a small amount of silicone grease. When re-installing the shaft, be careful not to push out the rear bearing. Tighten shaft end nut.*

To replace the steering assembly PCB, remove shaft end nut and tack ring. The PCB can be replaced after the retaining screws are removed.

To replace the steering wheel bushing assembly, use procedure 4 to remove the steering wheel, then remove the six retaining screws that hold the backing plate to the control panel. Withdraw the bushing assembly through the front of the panel.

## 1.10 REGULAR MACHINE MAINTENANCE

Due to its solid-state circuitry, your game will require very little maintenance other than periodic cleaning, lubrication and TV monitor adjustment.

The cabinet and plexiglas screen may be cleaned with any non-abrasive household cleaner. The coin acceptors, rejector linkages and the lock cylinders should be lightly sprayed once every three months with WD-40<sup>®</sup> or a spray lubricant. The TV monitor is adjusted *only* if the CRT picture is distorted or if the contrast or brightness are out of adjustment.

## 1.11 TROUBLESHOOTING PROCEDURES

The first step in any troubleshooting procedure is to correctly identify the observable symptoms of the malfunction. With these clues in mind, examine the areas of the machine which might cause these symptoms.

It is helpful for troubleshooting purposes to isolate three areas:

### 1.11.1 TV Monitor:

Many TV problems can be rectified with proper TV adjustment. However, if the problem persists or if the TV is undoubtedly malfunctioning, contact your distributor or remove the TV monitor and take it to a competent local TV repair shop. Complete TV

monitor repair manuals are available from your distributor.

#### 1.11.2 Printed Circuit Board:

Most PCB repairs may not be within your scope. If you can positively determine that your PCB computer has failed, contact the distributor from whom you purchased the game for repair or replacement instructions. Please be aware that some symptoms which might appear as PCB malfunctions may be the result of improper TV monitor adjustment or misadjustment of the small blue trim pots located on the PCB. *Do not attempt to repair the PCB yourself unless you have been specifically instructed to do so by your distributor.* To do otherwise will void your PCB warranty.

#### 1.11.3 Wiring Harness:

For troubleshooting purposes, the harness includes the line cord, the fuse, the A.C. line filter, the transformers, the interlock switch, the antenna wire, the start and coin switches, the steering assembly, the gear shifter, the pedal assembly, the PCB edge connector, the TV monitor, the speaker and all the interconnecting lengths of wire. A wiring enclosure diagram of the wiring harness and associated components has been included at the end of this manual to aid in troubleshooting.

#### 1.11.4 General Suggestions:

Following are some specific instructions and suggestions for troubleshooting your LeMans. To perform even the most simple troubleshooting procedures, you must have a VOM (Volt-Ohmmeter) and, if possible, a VTVM (Vacuum Tube Volt Meter) or digital voltmeter. It is also very helpful to have another LeMans game (or a spare TV monitor and PCB) available for substitution purposes.

For many problems, *substitution* may be the easiest way to troubleshoot the machine. For example, if you suspect a PCB malfunction, try substituting another and known-to-be-good PCB. If the malfunction disappears, the first PCB must have been cause. Conversely, if the malfunction persists, the cause of the malfunction must be located in either the TV or the harness.

The TV monitor can also be checked by substitution. Simply connect the game to a known-to-be-good monitor and if the malfunction is cleared up, the first monitor must have been the cause.

Harness must be checked by elimination. Substitute a known-to-be-good TV and PCB, and if the

malfunction persists, the harness and associated mechanical or electronic equipment must be at fault.

#### 1.11.5 TV Monitor Troubleshooting:

Some typical TV problems are distorted display, raster only or no video at all.

If you do not have a raster (a raster is a lighted but blank TV screen with the brightness turned all the way up), begin checking the power supply to determine if the TV is getting power. If the general illumination lamps of the machine are lighted, at least you know that power is reaching the machine. If not, check your line cord, interlock switch, fuse, etc.

If it is A.C. powered, go around to the back of the machine and with the rear door open (and interlock switch defeated) listen for a hum emanating from the monitor. If there is a hum, the monitor is powered and you may have a defective CRT or similar problem. Another test (and one which can be performed in a noisy environment) is to measure the voltage between the TV fuses and ground. If your voltmeter reads 110 volts or more, you know the monitor is powered. If not, check the fuses, the TV connections and the harness to see why power is not reaching the monitor. If the TV is powered but still not functioning, check the TV AC voltage switch which should be set to the "115" position ("115" visible on the switch) if it is connected to a 110-volt line source.

If you have the correct voltage after the fuses, but the monitor still will not function, you have two choices: 1). Remove the monitor and take it to a specialist, or 2). turn to the TV schematic and start exploring the monitor with a VTVM and an oscilloscope.

If you do have a raster, you must determine why there are no video signals being displayed on the screen: These video signals are generated by the PCB computer and enter the monitor through pin 1 of the TV monitor connector.

#### 1.11.6 Steering Assembly Troubleshooting:

Two small red LEDs have been included on the main PCB near position H8 to aid in troubleshooting the steering electronics.

Mounted on the small steering assembly PCB are two phototransistors and two infrared light-emitting diodes. The phototransistors are mounted behind the tack ring in such a way that the slots in

the wheel break up the light emitted from the diodes. This generates pulses which are used by the computer to determine how quickly and in which direction the wheel is being turned.

The test LEDs on the main PCB will light whenever the infrared diodes are stimulating the phototransistors (i.e., whenever the diodes are shining through the slots in the slotted wheel-onto the transistors).

To test the steering wheel assembly, simply rotate the wheel slowly in both directions while watching the two red LEDs on the main PCB. If your steering assembly is alright, both LEDs will flicker. If both of the LEDs fail to light (or remain lit constantly) while wheel is being turned, you definitely have a malfunction *before* the main PCB, which may be either in the wiring harness or in the steering assembly PCB.

#### 1.11.7 Troubleshooting by Symptom:

(a) *No Power*: Check for correct line voltage and if O.K. then check the fuse on the electronics tray, interlock switch and the transformer primaries.

(b) *No TV Picture*: Check for power as per procedure #a (No Power) and if alright, check TV connector and TV fuses. Measure voltage at TV fuses (should be 110 VAC) and if alright, replace the TV monitor.

(c) *TV Raster Only*: Check the harness and especially the PCB edge connector. If alright, check the TV as per the special test under "TV Monitor Troubleshooting." Or check TV or PCB by substitution.

(d) *TV Picture Rolls*: Adjust the TV vertical hold and if the rolling persists, check the TV or the PCB by substitution.

(e) *TV Picture Is Wavy*: Adjust the TV horizontal hold and if the problem persists, try replacing the transformer (in the TV monitor itself).

(f) *TV Picture Is Broken Into Diagonal Lines*: Adjust the TV horizontal hold and if the problem persists, check the TV or the PCB by substitution.

(g) *No Game Start*: Check the coin switches, the start switch, the harness and replace the PCB if necessary.

(h) *Game Shuts Off Accidentally*: Try cutting the antenna wire shorter in increments of 1-2 inches.

(i) *Picture Shrinks*: Check the line voltage with your VOM and be aware that a large motor starting up (i.e., an air conditioner) may drop the line voltage. Check to see that machine is firmly plugged in. If the problem only occurs at certain times of the day (especially at dusk), your trunk line voltage may be dropping.

(j) *No Audio*: Check the volume control, speaker connections and for 20 volts. If the problem persists, test the speaker, and if the speaker is alright, try replacing the PCB.

(k) *Game Sequence Incorrect, Parts of Race Course, Car, Score or Timer Missing or Distorted*: Replace the PCB or check for proper power supply.

(l) *Car Will Not Steer or Turn in One Direction Only*: Check PCB LEDs as Subparagraph 1.11.6 and if alright, then replace the PCB computer. If LED test is alright, check steering harness and connections and for foreign matter in steering assembly. Replace steering PCB if necessary.

(m) *No Brakes*: Check brake switch and wires from brake pedal switch to PCB. If alright, replace the PCB.

(n) *Brakes All The Time*: Check brake switch for foreign material and/or shorting terminals.

(o) *No Accelerator*: Follow procedure n for "No Brakes."

(p) *Accelerator All The Time*: Follow procedure o.

(q) *All Four Gears Dead*: Check connections and wires from gearshifter to PCB and if alright, replace the PCB.

(r) *One, Two, Three or Four Gears Dead*: Check the connections and harness of the malfunctioning gear(s): check the shift switch(s) for the malfunctioning gear(s). If problem persists, replace the PCB.

## II. PRINTED CIRCUIT BOARD: THEORY OF OPERATION AND SERVICING

### 2.1 INTRODUCTION

Le Mans is a fairly complex video game, and the operation of the circuitry must be learned before your troubleshooting attempts will be successful. However, after the basic differences are understood, it should prove no more difficult than any other Atari PCB.

The main differences between Le Mans and previous Atari games are the steering circuitry, the ROMs and the power supply.

The steering circuitry is a novel bit of engineering which employs phototransistors and infrared light-emitting diodes to generate pulses indicating the direction of steering wheel rotation. Fortunately, it is quite a simple circuit and easy to troubleshoot.

The ROMs are other chips which have been specially programmed for Le Mans and are used to generate the information for displaying of the car, score, game timer, and race tracks. Troubleshooting the ROMs is probably one of the easiest tasks because it involves only unplugging the suspected chip and replacing it with a known-to-be-good ROM.

The power supply is more complicated because additional voltages are needed to operate the ROM, the hybrids and the on-board audio amplifier. Even though there are a few more voltages to check, the basic power supply troubleshooting methods remain unchanged.

Because of this new circuitry, more test equipment is required to check the PCB. An oscilloscope is an absolute necessity and a logic comparator would be a wise investment.

#### 2.1.1 Test Equipment

Some of the following instruments are absolutely *essential* to fully test the PCB; others are desirable because they make the test procedures easier, but are not essential. Many of these items are available from the Atari Customer Service Department, 2175 Martin Ave., Santa Clara, CA 95050, and these items are indicated by an asterisk. A few others are available only from electronics supply houses or rental agencies; however, if you have dif-

ficulty in obtaining any needed instrument, contact our Customer Service Department for assistance.

#### (a) Required Equipment:

1. LOGIC PROBE\*: The logic probe is an instrument designed for checking the outputs of integrated circuits. We recommend the Kurz-Kasch Logic Probe, model #LP-520.

The logic probe will indicate if a signal is a logic high, low or changing from one state to the other. Consult the operating instructions included with the unit for further details on its operation.

2. VIDEO PROBE: The video probe is a simple, but useful, testing device. It consists of two IC test clips (or one clip and a test prod), a length of wire and a 4.7K, ¼-W carbon resistor. Video probes can be assembled from standard parts available at any electronics supply house.

To use the video probe, attach one clip to the negative side of the video coupling capacitor (C44) and clip or touch the other end to the desired signal test points as indicated in the following pages. The VP will display the signal directly on the CRT.

3. OSCILLOSCOPE: The oscilloscope is used for viewing various waveforms. Our application requires at least a 50-MHz scope and we recommend using a dual trace unit to facilitate comparison between waveforms. Our specific recommendation is the Tektronix model #465, 100-MHz dual trace oscilloscope.

4. THE TEST FIXTURE: Le Mans test fixtures are available from the Atari Customer Service Department. You may wish to fabricate your own unit. This should not prove too difficult and will familiarize you with how the machine is built. You will need a TV monitor, transformers, an AC line filter, a steering assembly, a gearshifter, a few momentary contact switches and a PCB edge connector. Use the push button switches to replace the coin, gas and brake switches in order to reduce the size of the unit. Follow the plan of the wiring harness schematic and the enclosure wiring diagram when assembling the components.

5. DIGITAL VOLTMETER: Model 8000 Fluke available from John Fluke Mfg. Co., Inc., Seattle, Wash. or equivalent with 10 M ohm input impedance.

(b) *Optional Equipment:*

1. **THE LOGIC COMPARATOR\***: This compact troubleshooting instrument will prove invaluable in verifying correct IC operation. The unit simply clips onto in-circuit ICs and instantly displays any logic state difference between the in-circuit test IC and the reference IC in the comparator. Logic differences are identified to the specific pin by a lighted LED.

If this instrument is purchased from the Atari Customer Service Department, it will be shipped with 20 pre-programmed reference boards. If the instrument is purchased elsewhere, you will have to program the boards yourself.

We recommend either the HP 10529A comparator or the Fluke comparator.

2. **THE LOGIC PULSER\***: The logic pulser is used to stimulate in-circuit ICs so they are driven to their opposite states and we recommend the HP 10526T pulser.

### 2.1.2 Troubleshooting Suggestions

The first step in the troubleshooting process is to correctly identify the observable symptoms of the malfunction and then to narrow down the possibly malfunctioning areas as much as you can. This should reduce the situation to one or two functional blocks which might be at fault. Then start examining these functional blocks with your test instruments and compare the results with the operational analysis and test point information under the heading of that functional block.

Keep in mind, however, that the first observable symptoms of a malfunction are not necessarily due to the functional block which produced those symptoms. A failure in one part of the PCB may affect much—if not all—of the PCB.

Some malfunctions may produce symptoms which are not clearly attributable to one component. Sync problems can be especially nasty in this regard because you can spend quite some time verifying the presence of correct sync signals on the board only to discover it is the monitor which is distorting sync.

This brings us to another subject: substitution as a troubleshooting technique. For instance, to clearly identify which component is at fault in a sync problem, try substituting a known-to-be-good TV monitor. If you have built a test fixture, plug the suspected board into the fixture and if the sync problem disappears, the other TV must have been the cause. Conversely, had the problem not disappeared, the substitution test would have revealed a

malfunctioning board and you would begin the troubleshooting process at the sync section.

The same technique can be used to test the ROM which is inserted in a plug-in type receptacle to facilitate the substitution test. If you have a problem with the car image, the race track display or the score or timer displays, try inserting another and known-to-be-good ROM and if this clears up the malfunction, leave it there. However, we must note that the ROM failure rate has been extremely low, so it is more likely that a display problem is located in either the ROM address circuitry or the display circuits.

There are a few other problems which need mentioning because, while they may at first appear to be board-related, closer examination will reveal they are location-related.

If the line voltage fluctuates enough, the electronic latch will turn off game credit. One cause of this may be a large load connected to the same line as the machine. For example, a large air conditioner while starting up may drop the line voltage enough to break the electronic latch. Another cause may be that the line voltage drops at certain peak times of the day, such as dusk.

The location power supply is suspect in any malfunction which occurs on an intermittent basis.

Another game credit problem which may be either constant or intermittent in nature is a maladjusted antenna wire. The antenna wire is connected to the electronic latch and if the wire is too long, game credit may be accidentally turned off, especially if the machine is in a carpeted location. For more information on the antenna's functions, see Paragraph 1.5 in Section I of this manual.

## 2.2 POWER SUPPLY AND BUFFERED START

+5 volts is used to power most of the ICs; however, the ROM requires -12 volts, and the dynamics and sound require -5 volts, +5 volts, +12 volts, and -12 volts. The +18 volt source is used only to drive the audio amplifier. A separate +5 volt regulator is used for the video output circuit.

The four circuits which generate the different voltages are very similar, as you will see. First, the 110 VAC line voltage is stepped down by the transformer(s) to 32 VAC and 16 VAC. These secondary voltages are then processed by the on-board power supply components to create the following voltages:

**+5 Volts:** To create the regulated +5 volts needed by the ICs (and other components as well), the AC waveform at edge-connector pins 2 and B (16 volts) is full-wave rectified by diodes CR4 and CR5. The resulting DC voltage is then filtered by capacitor C4 and then regulated to a constant +5 volts by the LM309 voltage regulator.

**+18 Volts:** The AC waveform at pins 3 and C (32 volts) is rectified by CR7 and CR9, filtered by C49 dropped 2.1V, and taken directly to the audio amplifier.

**-12Volts:** Because the cathodes of CR6 and CR8 are wired to the transformer secondary, the resulting voltage will be negative with respect to ground. This waveform is filtered by C15 and then lowered to -12 volts by R19. The resulting voltage is regulated by a -12V three terminal regulator.

**-5V, -12V, +5V Video:** These all use three terminal regulators.

**The Pull-Up Resistors:** The pull-up resistors (R6, R15, R69, etc., and denoted by the schematic symbol

"P") are used to provide a logic high source for inputs to ICs which need to be tied high. The resistor limits the total current drain through the LM309.

**Buffered Start:** In order to prevent a high and possibly destructive inductive kickback when the coil of the game counter is de-energized, a buffered start circuit has been incorporated so that the game counter is now tripped by a silicon-controlled rectifier (MCR 106-1).

The coin switch NC contact is connected to the gate input of the rectifier. When the signal goes high, the silicon-controlled rectifier conducts, thereby energizing the coil of the game counter. On the next half-cycle of the AC current, the rectifier is shut off by the AC waveform and the coin is de-energized.

### POWER SUPPLY TEST POINTS

TP 1: OSCILLOSCOPE: 32 VAC  
VOM/VTVM: 32 VAC

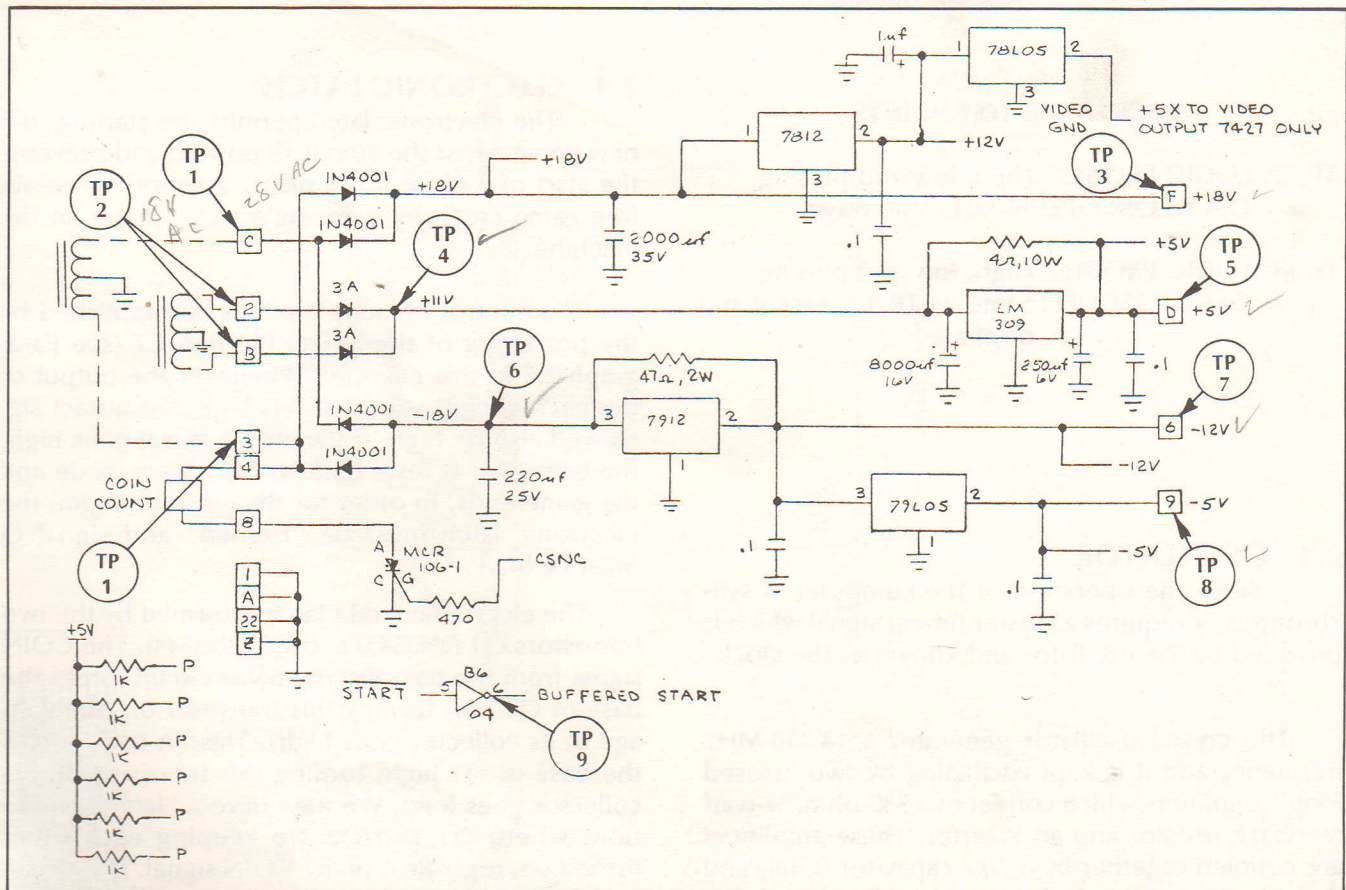

Figure 2-1 Power Supply and Buffered Start

- TP 2: OSCILLOSCOPE: 16 VAC  
VOM/VTVM: 16 VAC
- TP 3: OSCILLOSCOPE: +18 VDC  
VOM/VTVM: +18 VDC
- TP 4: OSCILLOSCOPE: 8.5 VDC  
VOM/VTVM: 8.5 VDC
- TP 5: LOGIC PROBE: High  
OSCILLOSCOPE: +5 VDC  
VOM/VTVM: +5 VDC
- TP 6: OSCILLOSCOPE: -18 VDC  
VOM/VTVM: -18 VDC
- TP 7: OSCILLOSCOPE: -12 VDC  
VOM/VTVM: -12 VDC
- TP 8: OSCILLOSCOPE: -5 VDC  
VOM/VTVM: -5 VDC
- TP 9: LOGIC PROBE: High pulse when the start switch is operated.  
OSCILLOSCOPE: High pulse when the start switch is operated.

### OSCILLATOR TEST POINTS

- TP 12: LOGIC PROBE: High, low and pulsing.  
OSCILLOSCOPE: 14-MHz sine wave.
- TP 13: LOGIC PROBE: High, low and pulsing.  
OSCILLOSCOPE: Same as TP 12, except out of phase.

## 2.3 OSCILLATOR

Since the operation of the computer is synchronous, it requires a master timing signal which is provided by the oscillator and known as the clock.

The crystal oscillator generates a 14.318-MHz frequency and it is kept oscillating by two "closed loop" amplifiers which consist of a 330-ohm, ¼-watt feedback resistor and an inverter. These amplifiers are coupled together by a .1µf capacitor (C46), and they operate out of phase with respect to each other.

Inverter A8 pins 3 and 4 is used as a buffer-amplifier; inverters A8 pins 5 and 6 and A8 pins 8 and 9 expand the oscillator's loading capacity.

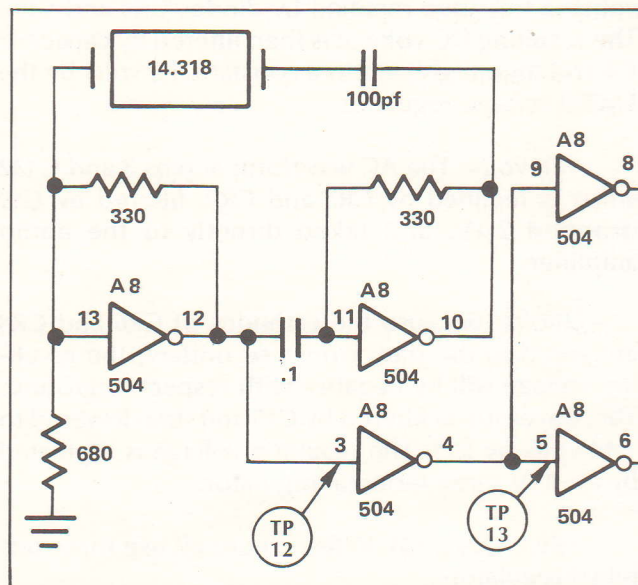

Figure 2-2 Oscillator

## 2.4 ELECTRONIC LATCH

The electronic latch permits the starting of a new game when the coin is deposited and prevents the start of a game if the player attempts to obtain free game credit by inducing a static charge in the machine.

The control of game credit is accomplished by the presetting of the attract flip-flop C7 (see Paragraph 2.5 in this manual). Whenever the output of the latch circuit—signal Q—is high, the attract signal will also be high. If the attract signal goes high, the computer is reset back to the attract mode and the game ends. In order for the game to begin, the electronic latch must be "latched" and signal Q must be high.

The electronic credit latch is formed by the two transistors Q1 (2N3643) and Q2 (2N3644). The COIN signal from the coin discriminator circuit forces the base of Q2 low, turning this transistor on (the voltage at its collector goes high). This, in turn, forces the base of Q1 high, turning this transistor on (its collector goes low). We now have a "latch" condition, where Q1 and Q2 are keeping each other turned on, regardless of the COIN signal. The circuit will remain in the latched condition until shut off by a low R signal or a high antenna signal.



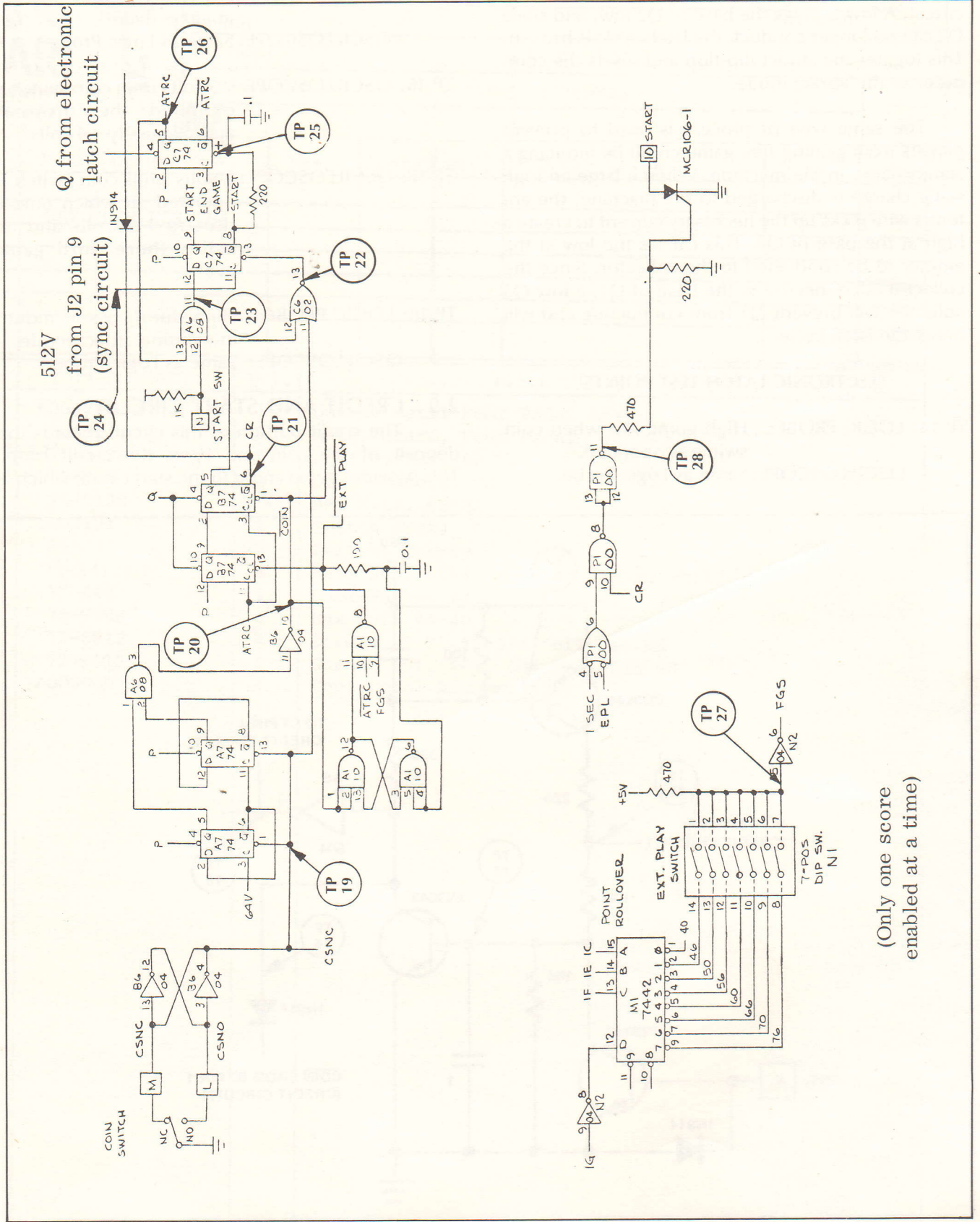

Figure 2-4 Credit and Start Circuit

(Only one score enabled at a time)

operated by the player to reset the PCB and begin the new game.

The deposited coin closes the normally-open side of the coin micro-switch, and the outputs of this switch are inverted by a "debouncing circuit" consisting of the two B6 inverters. The debouncing circuit eliminates undesired impulses created by the chattering of the coin switch contacts.

The debouncing circuit outputs enter the clear inputs of flip-flops A7. These two flip-flops constitute an anti-cheat device, designed so that incidental or player-induced vibrations that may operate the coin switch trip wire will not produce game credit. In order to get the correct outputs from the A7 flip-flops, the coin switch contacts must mate for at least 128 horizontal sync pulses, or 8.12 ms. Since most incidental or play-induced vibrations produce a coin switch mating of only a few hundred microseconds, the Q outputs of the flip-flops will not go high and no game credit will result.

However, if a coin is deposited, both A7 flip-flops are enabled, and when both of the Q outputs are high, pin 3 of AND gate A6 will also go high. This produces a low at pin 10 of inverter B6, clearing the second B7 flip-flop.

The same signal which cleared the B7 flip-flops (COIN) also drags the collector of transistor Q8 low and turns on the electronic latch (see Paragraph 2.4 in this manual), enabling the attract flip-flop C7 at pin 4.

Since the credit lamp must be lighted to enable gate C6, and since C6 enables the start flip-flop C7, the game cannot be started unless the credit lamp is lighted.

When the start switch is operated, pin 12 of AND gate A6 is pulled high by its 1K pull-up resistor. Since the attract line (A6 pin 13) is already high, pin 11 of A6 will go high. This produces a high at the D input of start flip-flop C7 at pin 12. Since the clock input of this flip-flop is connected to vertical sync at 512 vertical (J2 pin 9), the high at the D input will be clocked out 512V later and this is the start signal.

Meanwhile, START goes low and clears C7 at pin 1. This produces a low at the attract flip-flop output; it returns to shut off gate A6 at pin 13, thereby starting the game and locking out the start switch so the player cannot reset the computer during play and gain additional time.

The COIN signal also sets the cross-coupled flip-flop A1 pin 10, enabling the extended play (only one extended play granted per coin). The player's score 1C-1G are applied to a 1-of-10 decoder, and the high score output is selected by the DIP switch. If the player reaches the selected score, EXT PLAY goes low, setting B7 pin 13. Further, the EXT PLAY signal sets the extended play latch.

The credit light is enabled by the first coin, termed CR. When extended play is reached, the credit LED is then flashed by the one-second pulse.

#### CREDIT AND START CIRCUIT TEST POINTS

- TP 19: LOGIC PROBE: Low going high when the coin switch is operated.  
OSCILLOSCOPE: Same as logic probe.
- TP 20: LOGIC PROBE: High before coin switch is operated and high, low and pulsing while switch is held in the operated position.  
OSCILLOSCOPE: High before coin switch is operated and high with low-going pulses (frequency: 12.5 ms; duration: 4 ms) while coin switch is held in the operated position.
- TP 21: LOGIC PROBE: Low before coin switch is operated and high thereafter until game over.  
OSCILLOSCOPE: Same as for logic probe.
- TP 22: LOGIC PROBE: Low going high when coin switch is operated.  
OSCILLOSCOPE: Same as logic probe.
- TP 23: LOGIC PROBE: High going low when the start switch is operated. Stays low during the game.  
OSCILLOSCOPE: Same as logic probe.
- TP 24: LOGIC PROBE: Low and pulsing.  
OSCILLOSCOPE: Frequency: 16.66 ms; duration: 0.28 ms.
- TP 25: LOGIC PROBE: High with a low going pulse when the start switch is operated.  
OSCILLOSCOPE: Same as logic probe, except note that the low-going pulse is about 15 ms.

TP 26: LOGIC PROBE: High during attract mode and low during game mode.

OSCILLOSCOPE: Same as logic probe.

TP 27: LOGIC PROBE: Low when player score matches extended play score.

TP 28: LOGIC PROBE: Low when no credit. High when credit, but not in extended play. Flashing when extended play score is reached.

## 2.6 SYNCHRONIZATION AND BLANKING

A complex system of synchronization is required so the video signals generated by the PCB computer modulate the electron beam when the beam is in the correct part of the CRT. The essence of synchronization is timing. When sync is malfunctioning, the images appear to shift and move about the CRT because they are displayed in a different place each frame.

The PCB signals must synchronize with the electron beam horizontally so that the information on each line is displayed in the proper sequence (and also vertically so that the vertical positioning of the images is correct).

The sync pulses "tell" the electron beam when to start and stop its sweep, but do not otherwise control the raster. The sync circuit signals are also used in many other places in the PCB to time other operations with the TV monitor.

The basic timing for the horizontal sync circuit is the clock frequency. Vertical sync, however, runs off of horizontal sync. The horizontal and vertical sync counters count down the clock pulses to form timed pulse trains (see Figure 2-5).

The electron beam begins its sweep when horizontal sync goes low; this occurs after 902 clock pulses are counted out by the horizontal sync counters. The rising edge of the next H SYNC pulse occurs when the electron beam reaches the right-hand side of the CRT, and the beam is reset back to the left-hand side by the monitor.

H RESET resets the sync counters after 451 clock pulses or counts. This is the end of the half line segment, so the counters must be started again. Horizontal blanking (H BLANK) is initiated by H

RESET and lasts for 32 clock pulses. During the H BLANK time following H SYNC (every other H BLANK), information to be displayed in the next line is loaded into many parts of the PCB. The final horizontal sync signal (H SYNC) is composed of both H RESET and H BLANK and tells the electron beam when to start and stop its sweep.

Vertical reset serves the same purpose as H RESET, except it occurs after 521 horizontal blanking pulses (or half lines) when the electron beam is in the lower right-hand corner of the CRT. The V BLANK signal turns off the video during vertical retrace of the monitor. The vertical sync signal serves the same purpose as H SYNC, except it is timed to the vertical operation of the monitor.

The sync signals are generated in the following manner: the clock starts L2 counting, and when L2 reaches TC (terminal count), TC goes high and stays high for one clock pulse. Since TC of L2 is connected to CEP (count enable parallel) of K2, when TC of L2 goes high, K2 is advanced by one count by the clock pulse at pin 2. K2 then counts 15 clock pulses; then TC of K2 goes high (after a total of 255 clock pulses). The falling edge of the 256th clock pulse causes K1 pin 3 to go high, and it will stay high until the 451st clock pulse when it is reset by H RESET. This 256H is divided again at K1 pin 5, producing the 512th clock pulse or count. This is the line that divides the CRT in half.

H RESET is an output of H1, and it is created by the addition of 256H, 128H, 64H and 2H. The result at J1 pin 8 is a pulse 450 clock pulses from the last H RESET pulse. This is clocked through H1 by CLOCK, producing the H RESET signal.

Horizontal blanking is generated by H RESET, which presets the RS flip-flop composed of the F1 gates. This causes H BLANK to go high: 32 clock pulses later it resets the RS flip-flop, producing a blanking pulse 32 clock pulses wide after the H RESET pulse.

Horizontal blanking is then gated with  $\overline{\text{H RESET}}$  and 512H to produce  $\overline{\text{H SYNC}}$ .

Vertical reset is generated by horizontal blanking which clocks counter F2 at pin 14. The counter divides the clock frequency by 16; the output of this counter goes to H2, where it is again divided 16 times. The resulting signal is finally divided another four times by counter J2. J2 is allowed to divide only to four (a count of 512) because on the

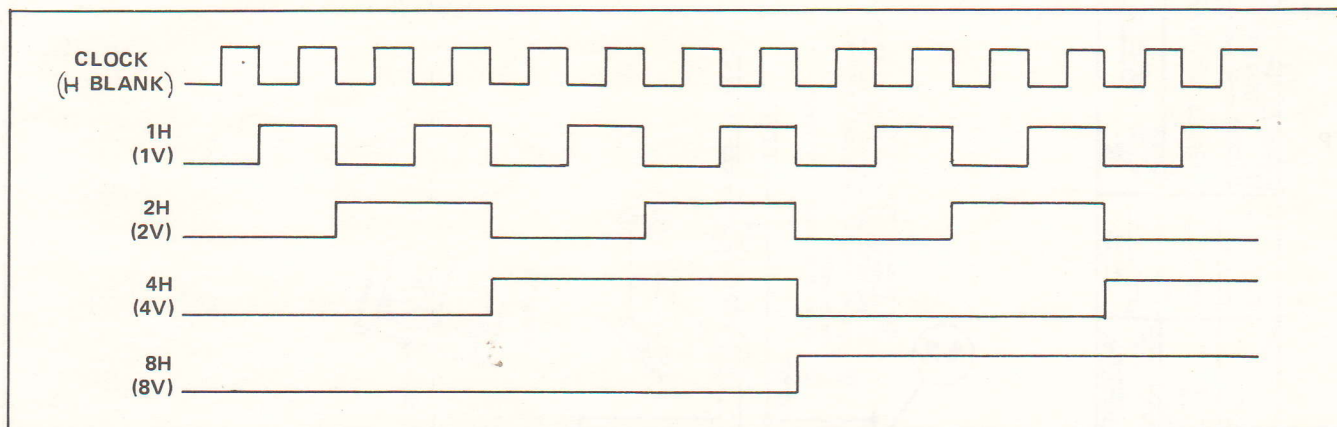

Figure 2-5 Sync Pulse Trains

521st count (512 plus 8V plus one more H RESET pulse) all the counters are reset by V RESET.

Vertical sync is created by the RS flip-flop F1, which is preset by V RESET and reset by 8V. This produces a high sync pulse which is four lines wide.

Because there are an odd number of half-lines being counted out, the electron beam must start at the center of the top of the screen every other field to achieve vertical reset. This is why the first line of the even field begins in the center of the CRT.

#### SYNCHRONIZATION AND BLANKING TEST POINTS

TP 29: VIDEO PROBE: A number of thin vertical white lines.  
 LOGIC PROBE: Low and pulsing.  
 OSCILLOSCOPE: Frequency:  $1.12 \mu\text{s}$ ; duration: 0.07 ms.

TP 29: VIDEO PROBE: Two vertical white banks.  
 LOGIC PROBE: Low and pulsing.  
 OSCILLOSCOPE: Frequency:  $32 \mu\text{s}$ ; duration:  $1.3 \mu\text{s}$ .

TP 29: VIDEO PROBE: Alternating black and white bands.  
 LOGIC PROBE: High, low and pulsing.  
 OSCILLOSCOPE: Frequency:  $32 \mu\text{s}$ ; duration:  $14 \mu\text{s}$ .

TP 30: VIDEO PROBE: Left half of CRT black; right half white.  
 LOGIC PROBE: High, low and pulsing.  
 Frequency:  $64 \mu\text{s}$ ; duration:  $28 \mu\text{s}$ .

TP 31: VIDEO PROBE: One thin vertical black line in center of CRT.  
 LOGIC PROBE: High and pulsing.  
 OSCILLOSCOPE: Frequency:  $32 \mu\text{s}$ , duration:  $0.1 \mu\text{s}$ .

TP 32: VIDEO PROBE: Thin vertical white line in center of CRT.  
 LOGIC PROBE: Low and pulsing.  
 OSCILLOSCOPE: Frequency:  $32 \mu\text{s}$ ; duration:  $0.1 \mu\text{s}$ .

TP 33: VIDEO PROBE: White vertical band in center of CRT.  
 LOGIC PROBE: Low and pulsing.  
 OSCILLOSCOPE: Frequency:  $32 \mu\text{s}$ ; duration  $2.3 \mu\text{s}$ .

TP 34: LOGIC PROBE: High and pulsing.  
 OSCILLOSCOPE: Frequency:  $63.5 \mu\text{s}$ ; duration  $2.3 \mu\text{s}$ .

TP 35: VIDEO PROBE: Starting with 2V, touch probe to all outputs up to 512V. Notice that the horizontal black and white bars double in width at each successive division.

TP 36: LOGIC PROBE: Low and pulsing.  
 OSCILLOSCOPE: Frequency:  $16.66 \text{ ms}$ ; duration:  $20 \mu\text{s}$ .

TP 37: LOGIC PROBE: Low and pulsing.  
 OSCILLOSCOPE: Frequency:  $16.66 \text{ ms}$ ; duration:  $30 \mu\text{s}$ .

TP 38: LOGIC PROBE: Low and pulsing.  
 OSCILLOSCOPE: Frequency:  $16.66 \text{ ms}$ , duration:  $254 \mu\text{s}$ .

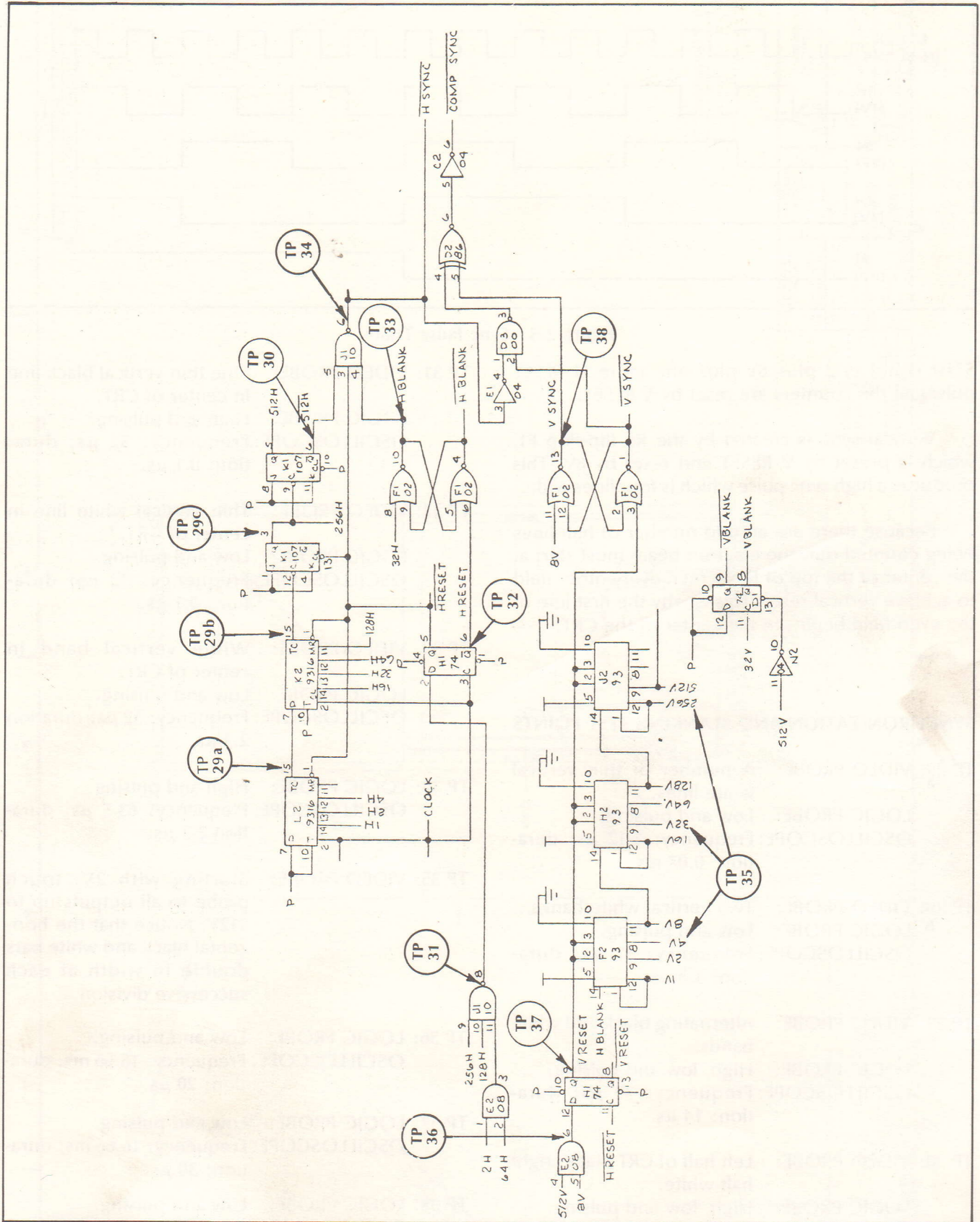

Figure 2-6 Synchronization and Blanking

## 2.7 SOUND CIRCUITRY

The noise generator uses a 16-stage pseudorandom number generator. This number of stages gives a nonrepetitive count of 65,535 states, which very closely approximates white noise. One troublesome feature with this type of counter is that there is always one lock-up state in which the counter would stop. To prevent this from occurring, an inverter is placed in one of the feedback branches, so that the clear input on the shift registers will set the counter to an active state. When the clear is released, the counter starts from that state and generates its pseudorandom pattern. This part of the sound system is the heart of the screech and crash sounds.

### 2.7.1 Screech Sound:

This sound is generated using a frequency-modulated oscillator. A 555 timer is used in the astable mode with the center frequency of ground 850 Hz. The output of the noise generator is fed into the FM input (pin 5) with the proper amplitude to simulate a screech sound.

The screech logic circuit generates the SCREECH signal, which creates the "screech" sound by enabling the noise and screech sound generator.

ATTRACT must be high (a game started) to enable the screech circuit. If SKID (the "brakes applied" signal) goes low presetting flip-flop C1, the SCREECH signal will go high. When SKID returns high, 1024V will be clocked through two frames later turning the SCREECH signal off.

## SCREECH LOGIC TEST POINTS

TP 39: LOGIC PROBE: High until brake switch is closed, then drops low.

OSCILLOSCOPE: Same as logic probe.

TP 40: LOGIC PROBE: Low going high when brake switch is closed. Same as logic probe.

### 2.7.2 Crash Sound:

To generate the crash sound, the output of the noise generator is modulated by a voltage-controlled amplifier. The VCA used is a MFC6040 (or MC3340) which generates an envelope amplitude proportional to the voltage applied to the control pin. When a crash occurs, the voltage on the control goes toward ground very rapidly, turning on the VCA. When the crash signal is removed, the voltage on the control pin is allowed to come back up. This is caused by current from the control input flowing into a capacitor. The capacitor prevents the voltage from building up at once, but at a rate set by the time constant of the circuit. This gives a decaying envelope to the sound which simulates a crash. The VCA also has a .01  $\mu\text{f}$  capacitor on the rolloff terminal to filter out some of the high frequency components of the sound.

### 2.7.3 Engine Sound:

This circuit creates the sounds of the car engine, both when it is idling and moving. This is accomplished with three function generators and one electronic attenuator.

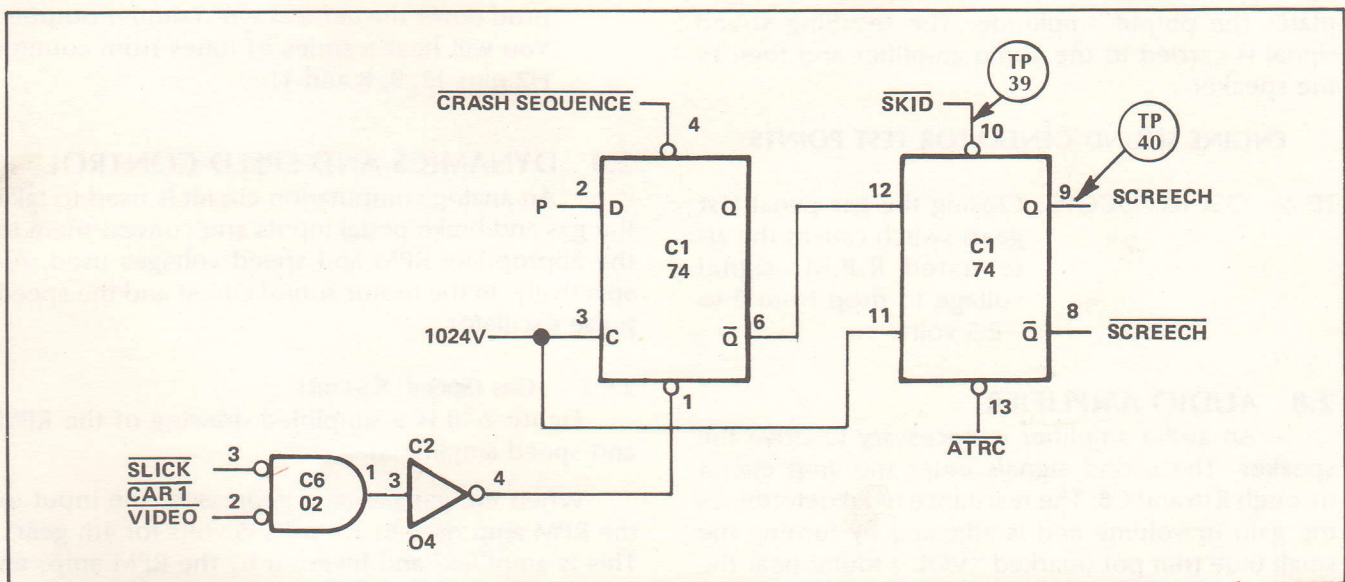

Figure 2-7 Screech Logic

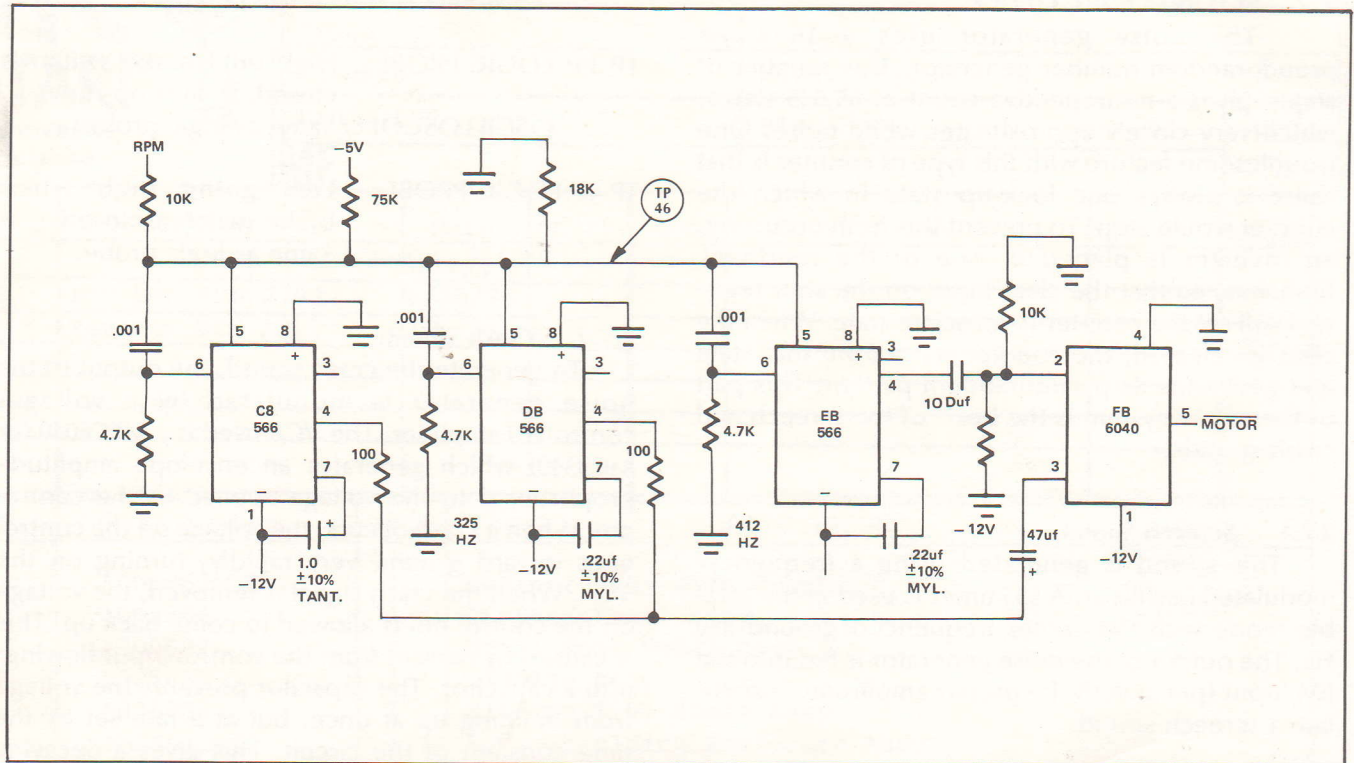

Figure 2-8 Engine Sound Logic

Closing the gas pedal switch drops the RPM signal voltage from 0 volts to about -3 volts, causing the function generators to modulate the frequencies of their signals.

The sound signals from C8 and D8 are the inputs to the voltage-controlled amplifier (VCA) (F8), and the signal from E8 to the control of the VCA modulates the output amplitude. The resulting sound signal is carried to the audio amplifier and then to the speaker.

#### ENGINE SOUND GENERATOR TEST POINTS

TP 46: OSCILLOSCOPE: Closing the gas pedal (1st gear) switch causes the attenuated R.P.M. signal voltage to drop from 0 to -2.5 volts.

### 2.8 AUDIO AMPLIFIER

An audio amplifier is necessary to drive the speaker. The sound signals enter the amp circuit through R16 and C8. The resistance of R4 determines the gain or volume and is adjusted by turning the small blue trim pot (marked "VOL") found near the LM380. The LM380 amplifies the sound signal to a level high enough to drive the speaker. Pin #1 is

used to turn off the sound in the attract mode. When this pin is pulled low, the amplifier is disabled.

#### THE AUDIO AMPLIFIER TEST

TP 50: Turn the volume down, attach the clip end of a video probe to capacitor C8 and run the prod down the vertical sync counter outputs. You will hear a series of tones from counter H2 pins 12, 9, 8 and 11.

### 2.9 DYNAMICS AND SPEED CONTROL

An analog computation circuit is used to take the gas and brake pedal inputs and convert them to the appropriate RPM and speed voltages used, respectively, in the motor sound circuit and the speed pulse oscillator.

#### 2.9.1 Gas (Speed) Circuit:

Figure 2-10 is a simplified drawing of the RPM and speed amplifiers.

When the gas pedal is depressed, the input to the RPM amp rises to 2.5 volts (5 volts for 4th gear). This is amplified and inverted by the RPM amp; an input from the acceleration circuit prevents the output from going negative instantaneously as



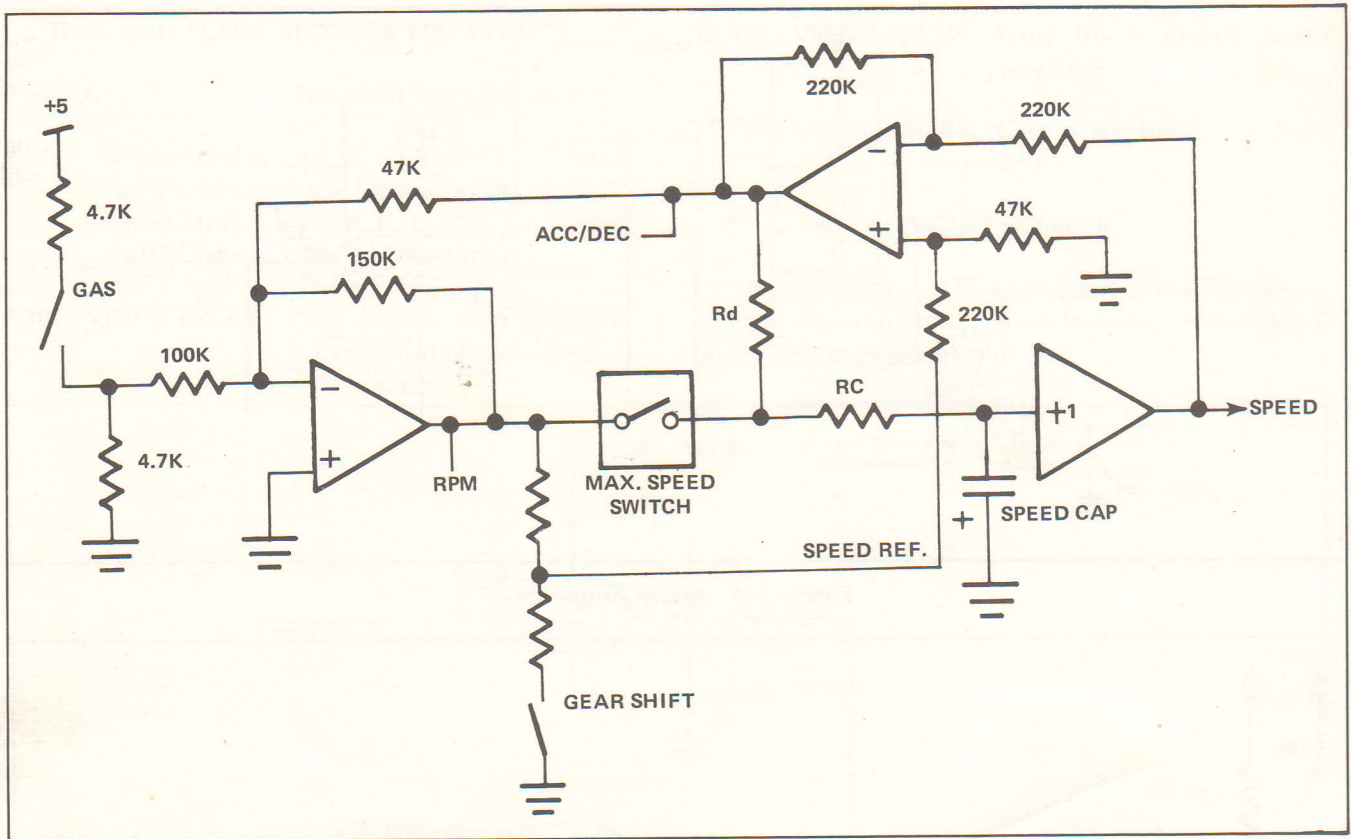

Figure 2-11 Acceleration/Deceleration Circuit

explained later. When the RPM voltage goes negative, the  $100 \mu\text{f}$  speed capacitor starts to charge in the negative direction. The capacitor voltage is buffered by the speed amp to provide the speed voltage out to the oscillator.

A speed reference signal is determined by the RPM voltage and the gear shift position. When the speed voltage reaches the speed reference, the speed switch comparator opens the max speed switch preventing the speed capacitor from charging further. The actual gear resistors are switched in remotely by analog switches.

The ACC/DEC circuit is shown in Fig. 2-11 above. When the gas pedal is pressed, the RPM voltage is coupled through the speed switch to the capacitor that begins to charge. The RPM voltage and the gear shift establish the speed ref voltage. The difference between the speed ref and speed voltages is obtained by the ACC/DEC amplifier. This difference is then fed back to the RPM amplifier to effectively limit the rate of RPM increase. When the car is at rest or at a constant velocity such as maximum speed in 1st, 2nd, or 3rd gear, the output of the ACC/DEC amp is zero and has no influence on the speed/RPM circuit.

If the car is in motion and the gas is let up, then the speed reference signal immediately goes more positive than the speed voltage, causing the maximum speed switch to open and the ACC/DEC amplifier output to go positive. This positive voltage is fed into the RPM amp to keep the RPMs "up." The positive voltage also causes current to flow through  $R_d$  and  $R_c$  to charge the capacitor towards ground, thus reducing the speed (compression).

If an upshift or downshift is made while the car is in motion, the speed ref voltage will change instantly and cause the ACC/DEC voltage to go negative or positive, respectively. This, in turn, causes the RPM voltage to decrease or increase depending on the direction of the shift.

As an additional note, the speed switch comparator causes the maximum speed switch to be closed during acceleration, open during deceleration, and partially closed or slightly oscillating for constant speed.

(a) RPM AMP Input/Output Conditions: The junction of the 4.7K and 100K resistors at the RPM AMP input is connected to the gas pedal switch that

controls the acceleration of the car. When the car is stationary or in gear with no gas, this point will be zero volts. When you step on the gas, this will increase to approximately 2.5 volts in first, second, and third gears and rise to +5 volts in 4th.

The RPM output (TP 59) is at 0 volts when the gas switch is open, and drops to about -3.6 volts when you step on the gas in first. When you shift into second, pin 3 rises to approximately -2 volts and then drops to about -3.8 volts as the car picks up speed. The same occurs on a shift from 2nd to 3rd. When you shift into 4th, it rises to -2 volts again and drops down to about -4.4 volts when the car reaches maximum speed.

(b) *Speed AMP Voltages:* The output of the speed amp is the analog of the car speed. This voltage starts at 0 volts and drops to -0.65 volts at top speed in first gear. When you shift into second, it drops to about -1.3 volts as the car picks up speed. When you shift into third, it drops to -2 volts and then drops down to about -3.5 volts when the car reaches maximum speed in 4th gear.

**2.9.2 Brake Circuit:**

Fig. 2-12 is a simplified drawing of the brake circuit.

When the brake is pressed, the PNP transistor is switched on, causing current to flow through  $R_b$  to charge the speed cap towards 0 volts. The discharge current is sensed by the skid amplifier—whose output goes low upon braking. When the capacitor has charged to a point near zero, but the car is still slightly moving, the  $I_{brake}$  current no longer causes sufficient voltage drop across  $R_b$  to overcome the slight bias introduced by  $R_H$  and the 1 Meg resistor. The  $\overline{SKID}$  signal goes high, thus removing the SKID condition.

When SPEED KILL goes high, the speed cap is charged to 0 volts immediately to kill the car speed. The limiter amplifier and diode prevents the voltage on the speed capacitor from going positive.

**2.9.3 Speed Oscillator:**

The speed oscillator is shown in Fig. 2-13. Assume that the timing capacitor has been charged through the diode and is now discharging through  $R_t$ . When  $V_{cap}$  reaches a voltage equal to  $V_{in, Comp. B}$  goes low to switch the flip-flop composed of cross-coupled gates. This in turn causes  $C_t$  to recharge to a negative voltage through the diode. When  $V_{cap}$  reaches  $V_{ref}$ , Comp. A goes low, resetting the flip-flop to allow  $C_t$  to again charge towards 0 volts.

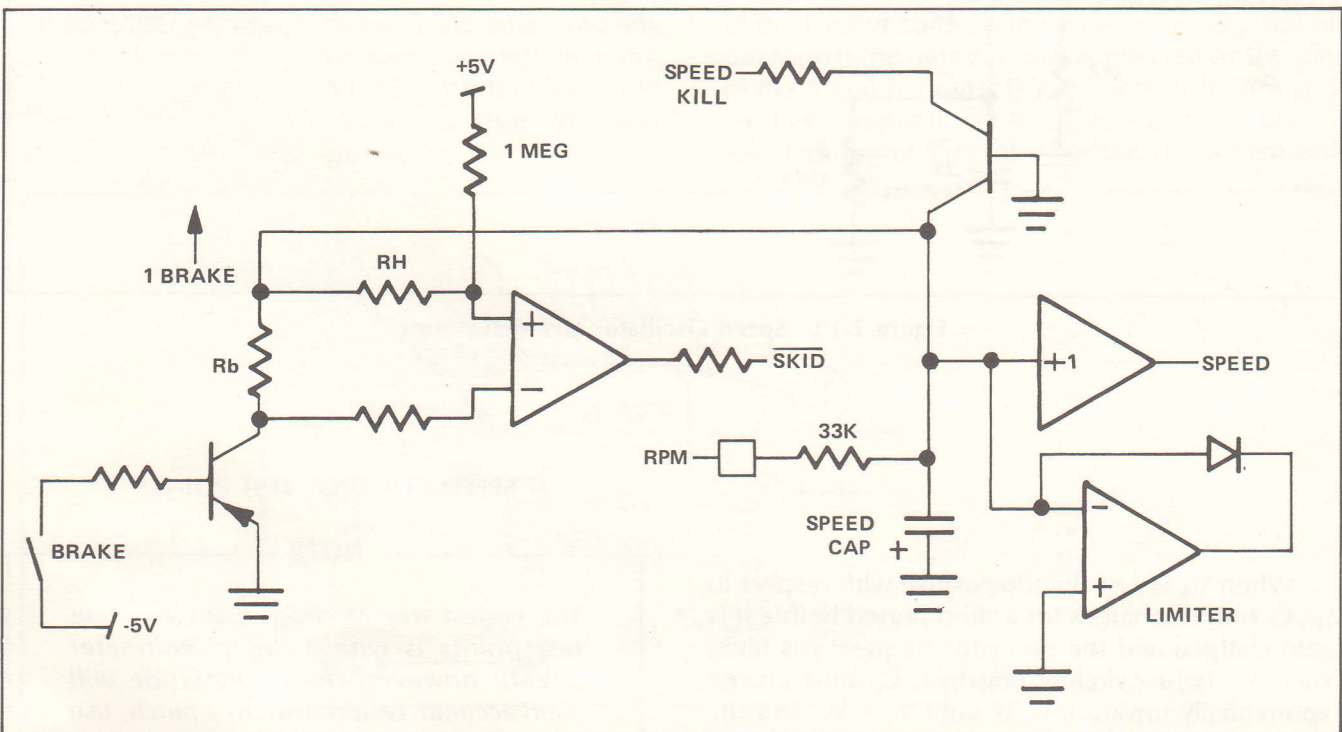

Figure 2-12 Brake Circuit

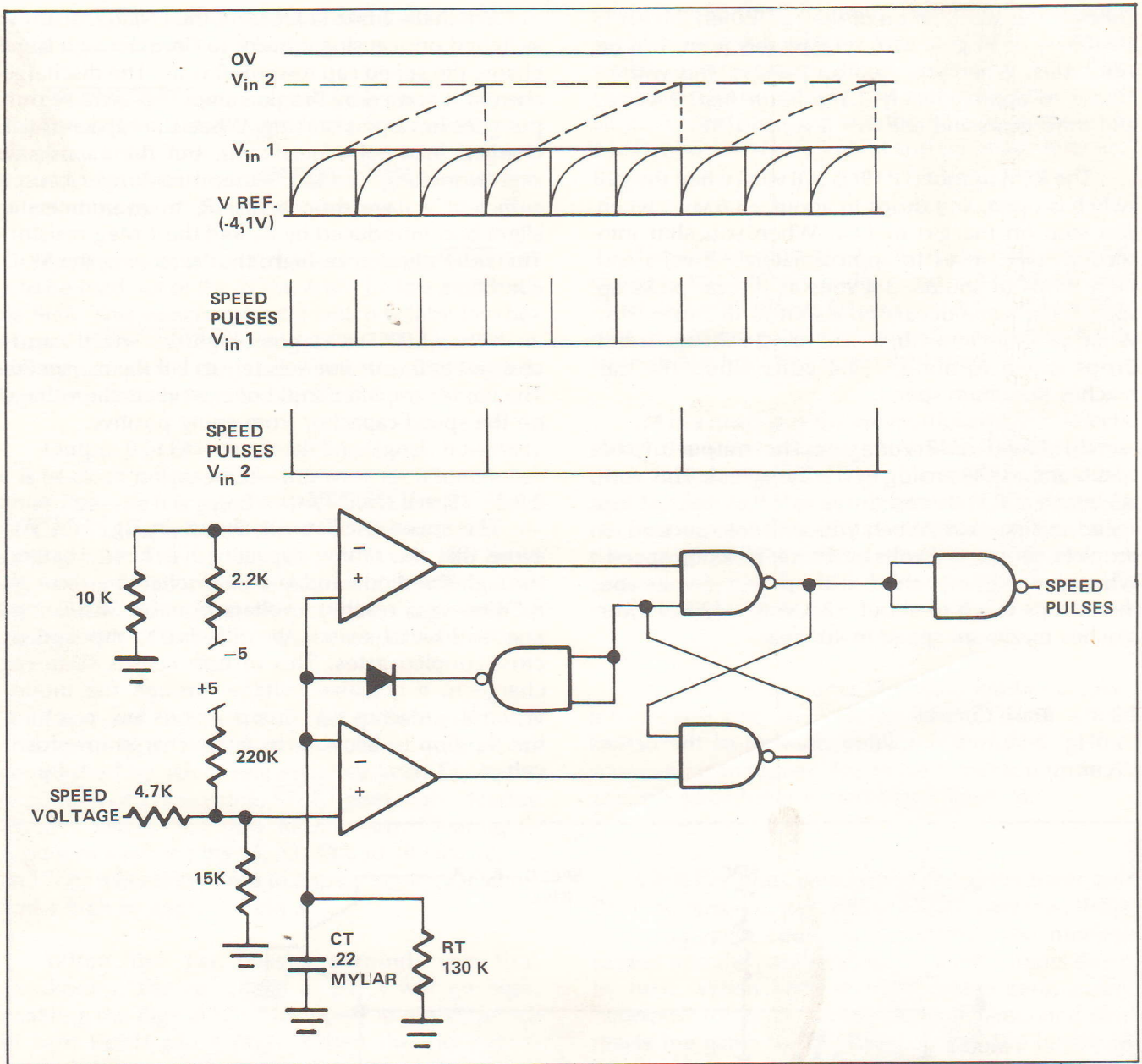

Figure 2-13 Speed Oscillator and Waveforms

#### SPEED CONTROL TEST POINTS

##### NOTE

The easiest way to check many of these test points is with a digital voltmeter (DVM); however, the oscilloscope will yield accurate results also. In a pinch, use a VTVM.

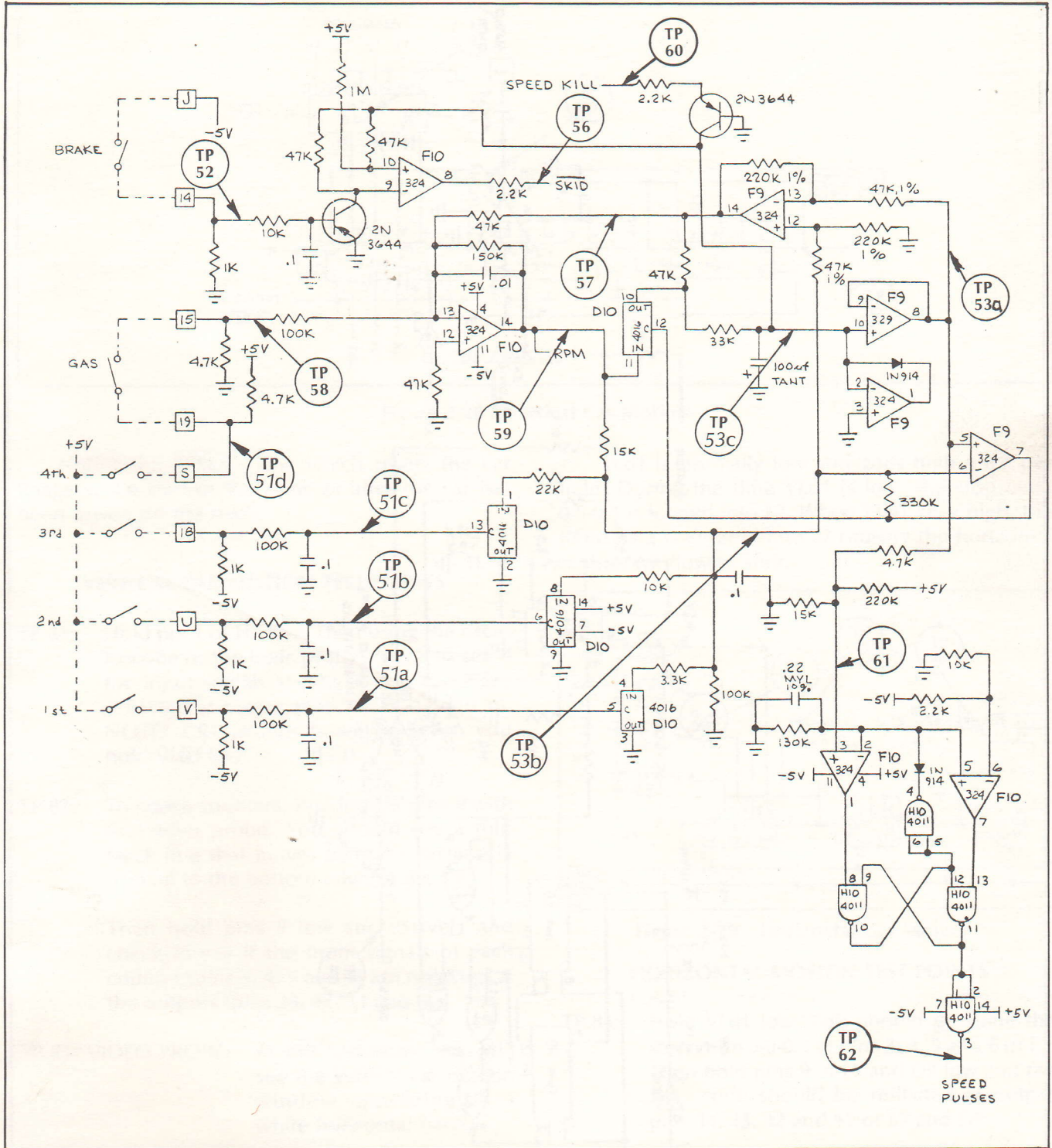

Figure 2-14 Speed Control



TP 51: LOGIC PROBE: Low going high as each shift is closed.  
 OSCILLOSCOPE: Same as logic probe.

TP 52: OSCILLOSCOPE: 0 volts, dropping to -5 volts when the brake switch is closed.  
 DVM/VTVM: Same as oscilloscope.

TP 53a: }  
 TP 53b: } (Note: voltages below refer to all three test points.)  
 TP 53c: } Check voltage drop with the oscilloscope or voltmeter as you reach top speed in each gear.  
 1st gear .....-0.65 volts  
 2nd gear .....-1.3 volts  
 3rd gear .....-2.0 volts  
 4th gear .....-3.5 volts

TP 54: LOGIC PROBE: Low, going high when a crash occurs.  
 OSCILLOSCOPE: 0 volts, rising to 3.5 volts at crash.  
 DVM/VTVM: Same as oscilloscope.

TP 56: LOGIC PROBE: High, going low when brake switch is closed (car in motion).  
 OSCILLOSCOPE: Same as logic probe.

TP 57: OSCILLOSCOPE: 0 volts when car is at rest or constant speed. -0.8 volts when acceleration starts and +0.8 volts when deceleration starts (gears 1-3 only).

TP 58: Check with oscilloscope or voltmeter. Voltage should increase from 0 volts to the indicated values as the gas pedal is depressed.  
 1st gear .....+2.5 volts  
 2nd gear .....+2.5 volts  
 3rd gear .....+2.5 volts  
 4th gear .....+4.3 volts

TP 59: Check with oscilloscope or voltmeter. Voltage should drop from 0 to the indicated values as you reach top speed in each gear.  
 1st gear .....-3.6 volts

2nd gear .....-3.7 volts  
 3rd gear .....-3.8 volts  
 4th gear .....-4.3 volts

TP 60: LOGIC PROBE: Low when car is at rest; high when car crashes or when game is in attract mode.  
 OSCILLOSCOPE: Same as logic probe.

**NOTE**

*Speed oscillator input/output conditions: As speed voltage into the oscillator input (TP 61) drops lower and lower, the speed pulses from the 4011 output buffer (TP 62) increase in frequency.*

TP 61: Check with oscilloscope or voltmeter. Voltages should drop from 0 volts to indicated values as you reach top speed in each gear.  
 1st gear .....-0.4 volts  
 2nd gear .....-0.9 volts  
 3rd gear .....-1.4 volts  
 4th gear .....-2.6 volts  
 Car at rest in any gear .....+.08 volts

TP 62: LOGIC PROBE: Low when car at rest; low and pulsing when car is moving.  
 OSCILLOSCOPE: Following readings are to be taken with car at top speed in each gear.  
 1st gear .....65 ms between pulses  
 2nd gear .....45 ms between pulses  
 3rd gear .....30 ms between pulses  
 4th gear .....15 ms between pulses

**2.10 VLd1 SIGNAL**

VLd1 ("vertical load one") is used to address the ready-only memory (ROM) for the vertical positioning of the car image.

$\overline{VRESET}$  clocks the low from B1 pin 12 out the Q output; this low waits at B1 pin 2 until it is clocked through by  $\overline{H SYNC}$ . The Q output (B1 pin 5) presets B1 pin 10, causing a high to appear at B1 pin 9. This high is clocked through B1 pin 5 on the next  $\overline{H SYNC}$  pulse. The result is a VLd1 pulse which occurs once per field and is one H SYNC pulse wide.

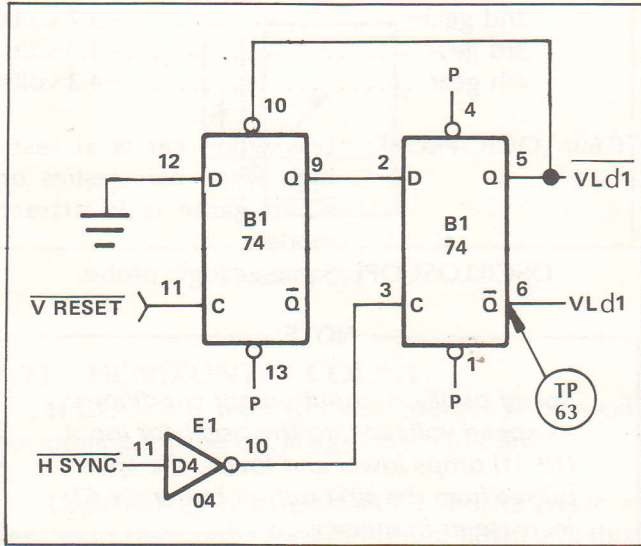

Figure 2-15 VLD1 Circuit

VLD1 TEST POINTS

TP 63: LOGIC PROBE: Low and pulsing.  
 OSCILLOSCOPE: Frequency: 16.66  $\mu$ s; duration 63.5  $\mu$ s.

2.11 1 STOP SIGNAL

This signal controls the address multiplexer to the ROM, to allow access to the speed codes in the ROM.

The input to this circuit is SPEED PULSE from pin 1 of the 8098 in the speed control circuit. As the car picks up speed, the speed pulses increase in frequency.

When the car is stationary,  $\overline{1\text{ STOP}}$  is low. As the car starts moving,  $\overline{1\text{ STOP}}$  begins pulsing high and the pulses get closer together and longer in duration until the car reaches top speed in fourth gear, at which time the signal stays high (see Figure 2-16).

TP 64: LOGIC PROBE: Low when car at rest. Low and pulsing when car is accelerating. High when car reaches top speed in 4th gear (provided speed pot is adjusted correctly).  
 OSCILLOSCOPE: See waveform illustrated above.

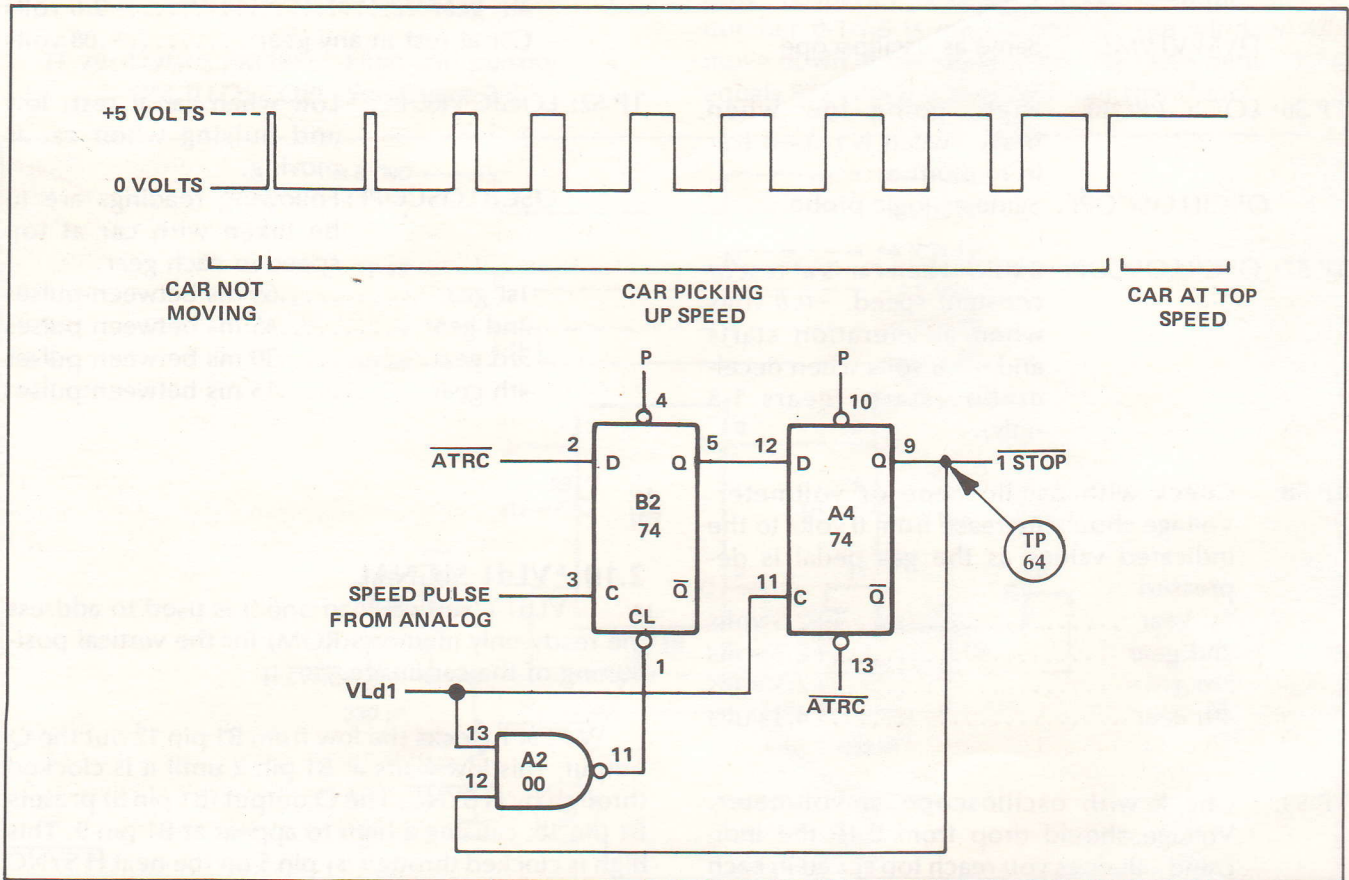

Figure 2-16  $\overline{1\text{ STOP}}$  Waveform and Circuit

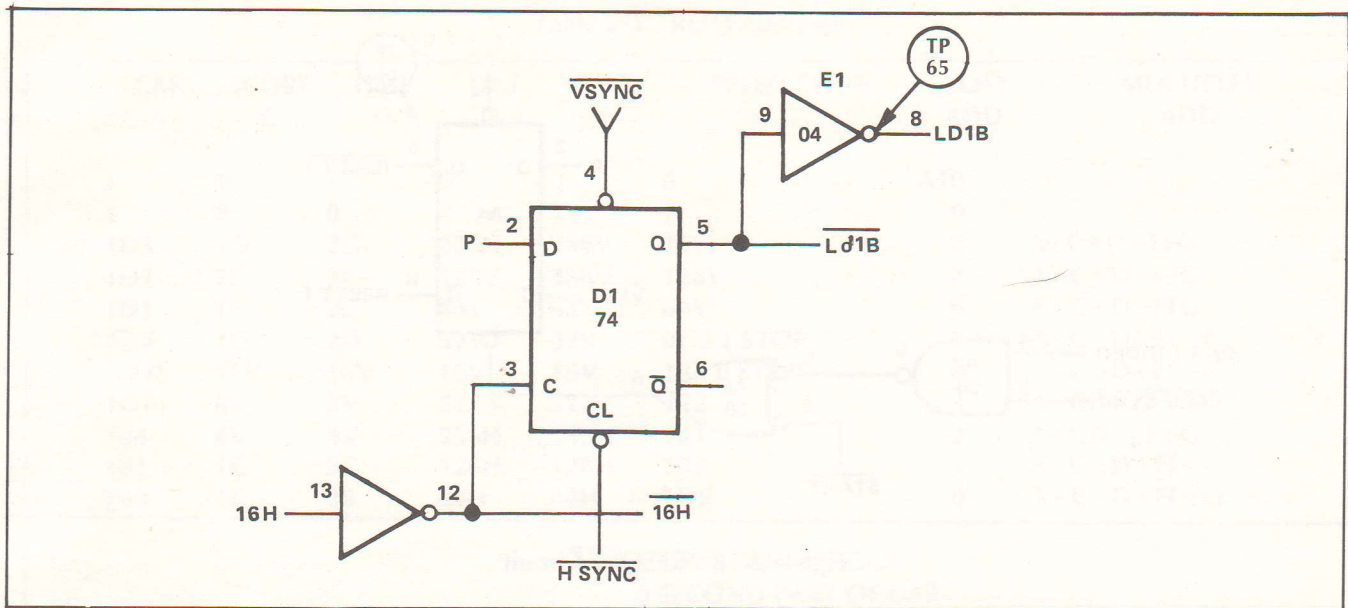

Figure 2-17 Ld1B Circuit

## 2.12 Ld1B SIGNAL

Ld1B ("load one B") is another control to the ROM address multiplexer; however, it is also used in several other places to load information into counters, etc.

$\overline{H SYNC}$  clears flip-flop D1. Sixteen clock pulses later, the high is clocked from the D input out the Q output and is inverted to become Ld1B.  $\overline{V SYNC}$  disables this function once per field, producing a wider Ld1B pulse.

### Ld1B TEST POINTS

TP 65: LOGIC PROBE: Low and pulsing.  
 OSCILLOSCOPE: Frequency: 63.5  $\mu s$ ; duration 5  $\mu s$ .

## 2.13 RESET 1 SIGNAL

The function of this signal is to tell the car motion circuits where to reposition the car image at the start of a new game or after the car is driven off the race course.

When CAR 1 VIDEO encounters  $\overline{COMP SYNC}$  (i.e., the car is driven off the screen), A2 pin 6 goes low and causes a low to appear at A6 pin 5. The last low clears flip-flop A4. The flip-flop remains cleared until it receives the next  $\overline{VLD1}$  pulse which clocks the high from A4 pin 2 out A 4 pin 5: this signal is known as RESET 1.

$\overline{START}$  serves a function in the circuit similar to the low from A2 pin 6: it also clears RESET 1.

## RESET 1 TEST POINTS

TP 66: LOGIC PROBE: Low pulse when the game starts or the car is driven off the track.

OSCILLOSCOPE: Same as logic probe.

## 2.14 STEERING CONTROL

The two infrared light-emitting diodes (LEDs) mounted on the steering assembly PCB are aimed directly at the two phototransistors. As the slotted steering ring rotates, the path of light is broken up causing the phototransistors to pulse in a way which corresponds to the direction of the steering wheel rotation. These pulses are fed into four-input Schmitt triggers (J8) which clean up the pulses so the flip-flops can be triggered consistently.

When the steering wheel is turned in a clockwise direction, a rising edge occurs at the clock input of K8 before a rising edge reaches the D input. This causes the CW (clockwise) signal to be high, enabling gate A2 to advance the steering encoder (see next section of this manual); the steering encoder rotates the car in a clockwise direction.

However, if the steering wheel is rotated in a counterclockwise direction, a rising edge will occur at the D input before a rising edge reaches the clock input. This produces a low CW signal.

The RATE signal triggers A4, providing a pulse to decoders A2 and A3. Depending on the direction



when steering wheel is turned counterclockwise.

OSCILLOSCOPE: Same as logic probe.

TP 68: LOGIC PROBE: Pulses when steering wheel is turned, and pulse rate rises as wheel is turned faster.

OSCILLOSCOPE: Same as logic probe.

TP 69: LOGIC PROBE: Pulses when steering wheel is turned clockwise. High when steering wheel is turned counterclockwise.

OSCILLOSCOPE: Same as logic probe.

TP 70: LOGIC PROBE: Pulses when steering wheel is turned counterclockwise. Low when steering wheel is turned clockwise.

OSCILLOSCOPE: Same as logic probe.

TP 71: LOGIC PROBE: Pulses except when steering wheel is turned counterclockwise or when a crash occurs.

OSCILLOSCOPE: Same as logic probe.

## 2.15 STEERING ENCODER

The steering encoder directs the ROM to read out the different aspects of the car image as the steering wheel is rotated.

The steering control circuit decides whether to pulse the UP ("U" at J3 pin 5) or the DOWN ("D" at J3 pin 4) line of the J3 up/down counter. As the up input is pulsed, a binary code results at output pins 6 and 7 of J3. After 16 pulses into the up input, a "carry" pulse is produced at J3 pin 12. This advances K3, which then produces another binary code at output pins 2, 3 and 6.

However, if the down input to J3 is pulsed, J3 will count down from the last loaded number and, when it reaches 0, a "borrow" pulse is generated at J3 pin 13, decrementing K3.

At the beginning of the game, or if the car is driven off the track, RESET 1 goes low. This resets the counters to zero and re-orientes the car image.

L3 is a latch which takes the 1D1, 1D2, 1D3 and 1D4 outputs from the counters and passes these signals on to the ROM multiplexers unless SCREECH is high. A high SCREECH latches up the last information from the counters and holds it until SCREECH goes low again. This causes the car image to continue moving in the same direction it was going when the brakes were applied, even if the steering wheel is turned which produces a realistic "slide" or "drift."

## STEERING ENCODER TEST POINTS

TP 72: LOGIC PROBE: Changes state twice for every complete car image revolution.

OSCILLOSCOPE: Same as logic probe.

## 2.16 CRASH AND PLAYTIME

This circuit has two functions: (1) it generates the crash signal when the car is driven into the pylons, and (2) it times the length of the game.

The 555 timer at B8 is the component that actually provides the timing. The amount of time it takes to charge C43 determines the pulse width out of the 555, and controls the period of time the output signal 1 SEC is high. R72 adjusts both the crash time period and the playtime by varying the amount of time required to charge the capacitor. The timer output is used to clear the crash flip-flops after a crash has occurred. It is also the input to the game timer circuit that turns the game off after it counts a certain number of 1 SEC pulses.

This circuit also generates the crash signal (CRASH A) whenever the car window encounters the race track signal by gating the two signals together at D5. A crash produces a low at D5 pin 3 that clears both B5 flip-flops. 2048V after the car is off the pylon, a low is clocked out of B5 pin 8. During the time this pin is high, flip-flop C5 is enabled and asks the question, "Is there a car on the pylons?" If the answer is "no" (i.e., one of the wheels has just barely glanced off a pylon), C5 continues to repeat the question until it is cleared at pin 13 by a low from B5 pin 8.

However, if the answer to C5's question is "yes," C5 pin 8 goes low, causing D5 pin 11 to go high. Then the "yes" information is latched into C5 at pin 5, producing a high at CRASH A and a low at CRASH A. A low CRASH A produces a low SPEED KILLS signal from D5 pin 8 that stops the car motion. A low ATTRACT will also produce a low SPEED KILLS



and stop the car whenever the computer is in the attract mode.

### CRASH AND PLAYTIME TEST POINTS

TP 74: LOGIC PROBE: High with low pulses approximately once per second. NOTE: Frequency of 1 SEC is adjustable by R72.

OSCILLOSCOPE: Same as logic probe.

TP 75: LOGIC PROBE: High when the car crashes or when game is in attract mode.

OSCILLOSCOPE: Same as logic probe.

TP 76: LOGIC PROBE: Drops low when the car encounters the race track.

OSCILLOSCOPE: Same as logic probe.

TP 77: LOGIC PROBE: High pulse when the car crashes.

OSCILLOSCOPE: Same as logic probe.

TP 78: LOGIC PROBE: Normally high, low and pulsing; changes to high when a crash occurs.

### 2.17 TRACK SELECTION

On Le Mans, every time the player completes a lap a new track is displayed. Each track is more complex than the preceding track. The track select is TSA, TSB, and TSC. During the game mode, the track select is jammed set with the lap count from the score—1E, 1F, 1G, and 1J. During the attract mode, the 193 is no longer parallel loaded but is counting at a 4-second rate. The attract mode shows Le Mans stepping through the tracks.

On lap 7 and 8, either tracks 7 and 8 or tracks 9 or 10 are displayed. The flip-flop (see ROM select page) picks up data from the 2-second timer to randomly display either tracks 7 and 8 or 9 and 10.

During extended play, the player starts with a score of zero, but play resumes on Track 5. Tracks 1-4 are the "learner" tracks and are not used for extended play. The cross-coupled 7400 gates force TSC high in the extended play mode.

### 2.18 MEMORY CIRCUIT

This circuit stores information which is later read out for the generation of the car image, the race track display and the score and timer displays.

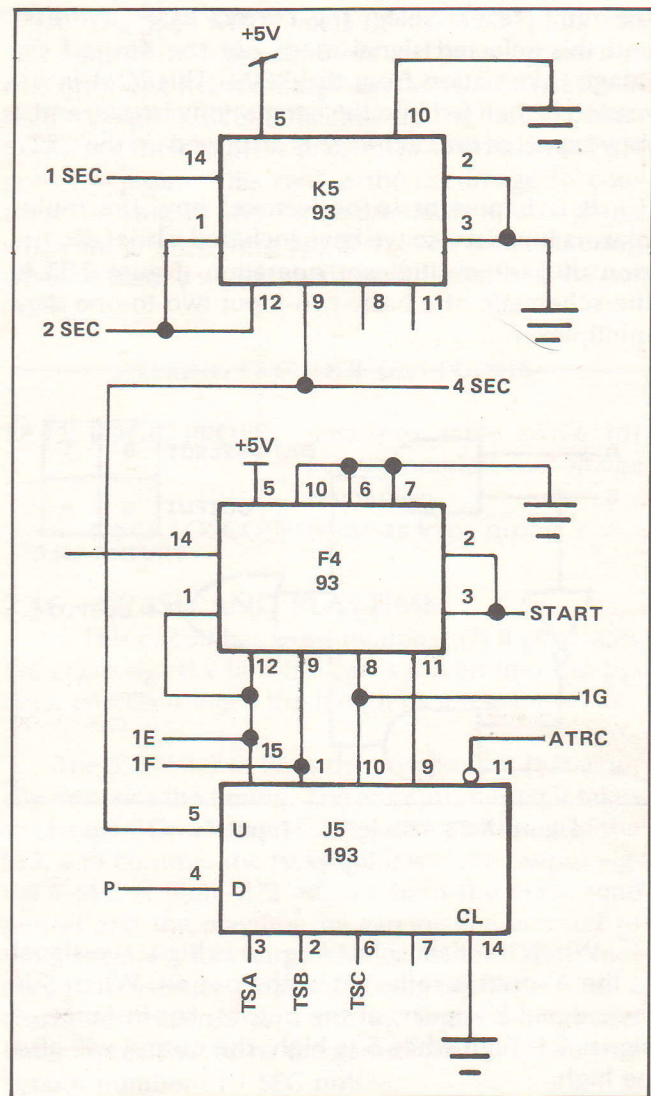

Figure 2-22 Track Selection

The main components are four multiplexers and three 16K ROMs (read-only memories) that have been specially programmed for Le Mans.

The ROMs are memory units that store binary information. This information is read out of the ROMs by the multiplexers, and these outputs go to other circuits where the information is used to form the different aspects of the car image, the race track display, etc. The ROMs each store 2048 eight-bit words.

Multiplexers select certain signals from a larger input of signals, and these output signals are the "addresses" for the ROM. A different multiplexer address is required to read out each different eight-bit ROM word. For example, when information is needed for the generation of the car image,

the multiplexers select the correct ROM address, and this selected signal reads out the desired car image information from the ROM. This ROM information is then fed into the car motion circuits, and a new aspect of the car image is displayed on the CRT.

It is important to understand how the multiplexers function, so we have included a brief discussion of basic multiplexer operation. Figure 2-23 is the schematic of a basic two-input two-to-one data multiplexer.

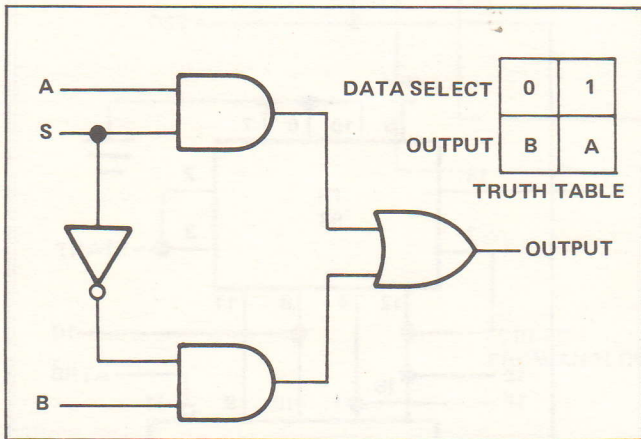

Figure 2-23 Basic Two-Input Two-To-One Multiplexer

When the data select line (S) is high, the signal at the A input is reflected at the output. When S is low, signal B appears at the output. For instance, if signal A is high while S is high, the output will also be high.

The multiplexers used to address the ROM are nothing more than elaborations on the foregoing theme. Figure 2-23 shows a two-input, two-to-one multiplexer; the ROM requires eight-input, four-to-one multiplexers.

The ROM itself is not a particularly complicated device; it is useful only because it can store so much information in a small space. Visualize the ROM as being constructed from 2048 rows of 8 diode gates each, where each gate is connected to one of the eight ROM outputs. Each diode in every row is specially programmed so that it reads out either a high or a low when it is addressed. Each row of eight gates must be addressed by a different binary number. When this number is read out by the multiplexers into the ROM address inputs, each diode in that row reads out its high or low to one of the ROM outputs.

*Troubleshooting the ROM Circuit:* Some typical symptoms of malfunctions in this circuit are a distorted or missing car image, portions of the race track distorted or missing, or distortion of the lap counter or game timer displays.

If you suspect trouble in this section, the first step is to replace the appropriate ROM (see Table 2-1 below). Plug-in type receptacles have been provided to facilitate replacing the ROM. If the malfunction disappears, leave the new ROM in. However, the ROM failure rate is extremely low, so if a new ROM does not fix the problem, go on to the following troubleshooting procedures.

Table 2-1

	$A^9 \rightarrow$		0	1	0	1	0	1
$A^{10} \downarrow$	0	1	RT	RT	RT	RT	RT	RT
	9	10	1	2	5	6		
1	Score	Car	RT	RT	RT	RT	RT	RT
			3	4	7	8		
			ROM 0		ROM 1		ROM 2	

If the ROM is alright, next check the ROM addresses at ROM inputs  $A^0$ - $A^8$ . If these addresses are not alright, check the inputs to the multiplexers, the multiplexed outputs and any gating that may be between the multiplexer outputs and the ROM inputs.

The ROM address table is invaluable in troubleshooting this section. We will use a car image problem to demonstrate the use of the address table.

To find the correct address for the car image at the ROM inputs, look under the column labeled CAR A. Then clip the scope probe to the device that the ROM information is to be read into, which is shift register F6. The probe should be placed on the pin which is used to control when the data will be entered; in this case it is the shift load input (S/L) at pin 1. When the shift load pin goes low, the information will be loaded into the register.

Then take the second probe and check the ROM address inputs and compare these with the information at the multiplexer inputs. Finally, compare all of this information with the table.

For example, first check ROM address  $A^8$  (pin 15) with the second probe, and you should see a high pulse occurring at the same time as the low shift

Table 2-3 ROM Addresses

CAR A	SCORE C	TIME D	1R.T. E	2 R.T. F	SPEED CODE G	ROM ADD	MULTIPLEX ADD
1	1	1	0	0	0	A10	
1	0	0	0	1	1	9	
1D3	1G	2G	256V	256V	256V	8	A+C+D+EFG
1D2	1F	2F	128V	128V	128V	7	A+C+D+EFG
1D1	1E	2E	64V	64V	64V	6	A+C+D+EFG
1D0	1D	2D	32V	32V	0G0 1 STOP	5	A+C+D+EF+G
$\overline{32H}^*$	16V	16V	16V	16V	1R3 0 STOP	4	A+C+D+EF+G
1D4	8V	8V	512H	512H	1R2	3	A+CD+EF+G
104	4V	4V	256H	256H	1R1	2	A+CD+EF+G
103	1C	2C	128H	128H	1R0	1	A+C+D+EF+G
102	1B	2B	64H	64H	1D0	0	A+C+D+EF+G

\* $\overline{32H}$  1 FIRST PART OF CAR  
0 SECOND PART OF CAR

load pulse. Note that this correctly corresponds to the ROM address table. Then look at A<sup>9</sup> (pin 8); again there should be a high pulse occurring simultaneously with the low shift load pulse. Now go to A<sup>8</sup>, and you should see signal 1D3 pulsing high and low as the steering wheel is rotated.

Continue to check all the address inputs in the same fashion. If you find some information that does not correctly correspond, start checking back through the multiplexers and gates, if any. If all the information checks out, examine the component that information is being loaded into (shift register F6 in this case).

The multiplexers are most easily checked using a logic comparator (see subparagraph 2.1.1). The comparator will yield fast and accurate results. If you do not have a comparator, use the following procedure: first tie both multiplexer select lines low and look at the information from pins 7 and 9 (multiplexed outputs) which must match the inputs at pins 6 and 10 (multiplexer inputs). If alright, tie S<sub>1</sub> high and S<sub>2</sub> low, and pins 7 and 9 should match 5 and 11. If alright here, tie S<sub>1</sub> low and S<sub>2</sub> high, and 7 and 9 should equal 4 and 12. To check the last set, tie both select lines high and pins 7 and 9 should match 3 and 13. The enables 0-2 enable the appropriate ROM, depending on the function. Signal ABCD is true for score and car display.

To troubleshoot the multiplexers, first check the multiplexer inputs. If any of these do not check out, go to the section that produces the malfunctioning signal and locate the malfunction there.

However, if all the multiplexer inputs are alright, check the data select lines by going to gates H3 and L5. Verify the presence of the correct Ld1B, VLd1, 512H and SCORE DISP inputs. If all of the data select inputs are also alright, you must check the multiplexers themselves.

## 2.19 WINDOW CONCEPT

After the video signals are generated by the computer, they must be displayed in the desired part of the CRT. This is done by directing the signals to appear only within a certain area or "window." The key idea behind the window concept is that of limits or boundaries.

Your video probe is a test instrument that can be used to display the windows directly on the CRT. To see a graphic display of windows, attach one probe clip to the negative (-) side of the video coupling capacitor (C44) and run the other end across the sync counter outputs.

You probably noticed, as you ran the probe across the vertical sync outputs, that the resulting windows were horizontal in appearance. The most confusing part of the window concept is the fact that it takes vertical signals to define a horizontal window and vice versa.

Examine Figure 2-25a and notice the vertical signal 256V that defines a horizontal line approximately half way down the CRT. Since the raster is composed of 521 half lines (or 260.5 whole lines), the signal 256V "tells" the electron beam to modulate its scan

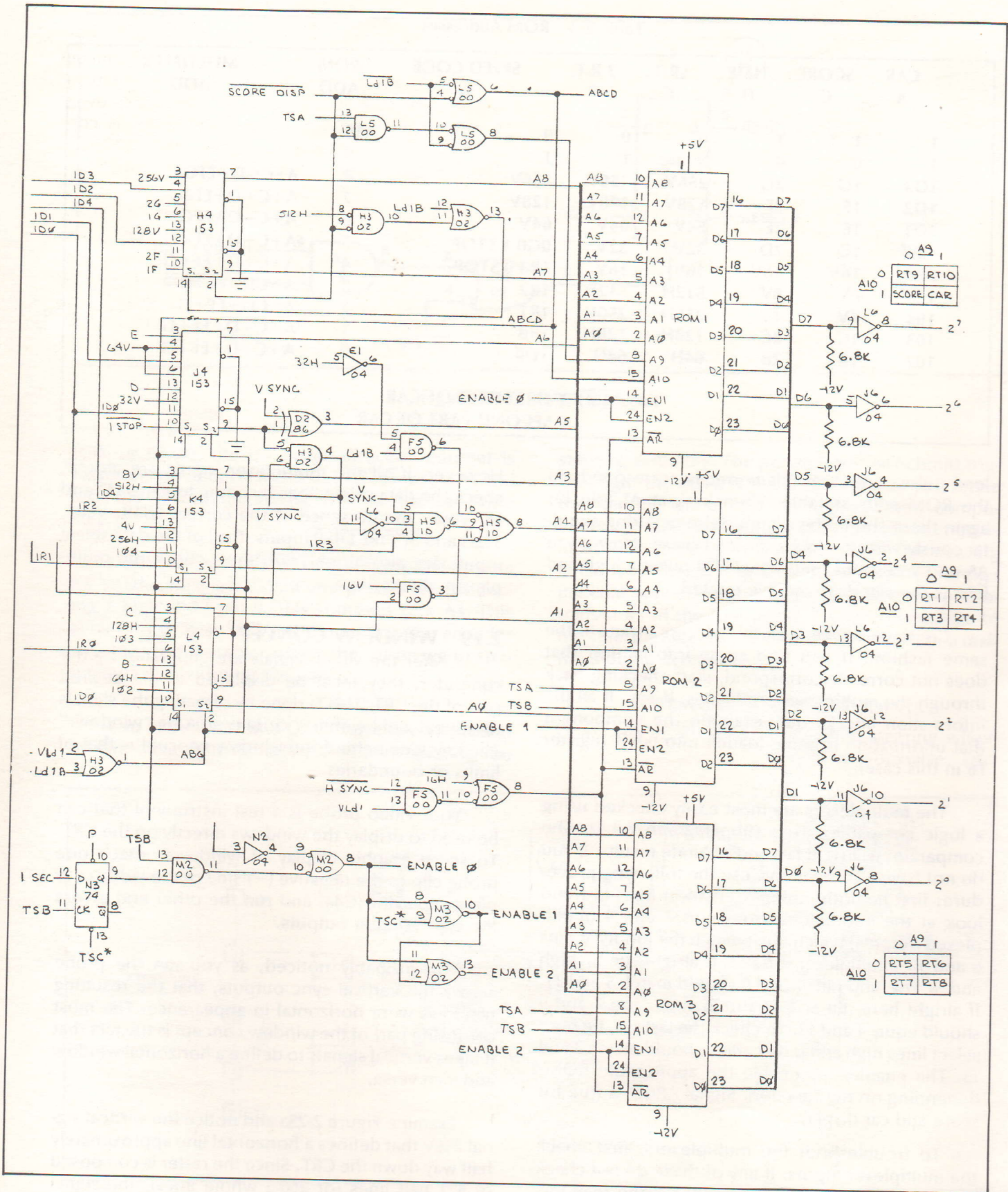

Figure 2-24 Memory Circuit

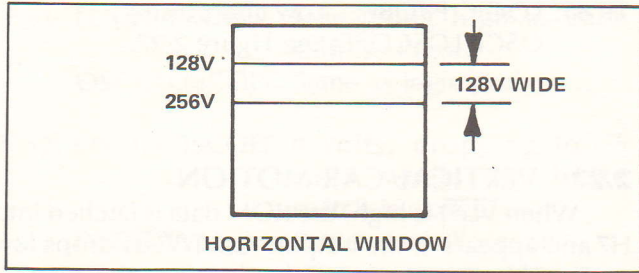

Figure 2-25a Horizontal Window

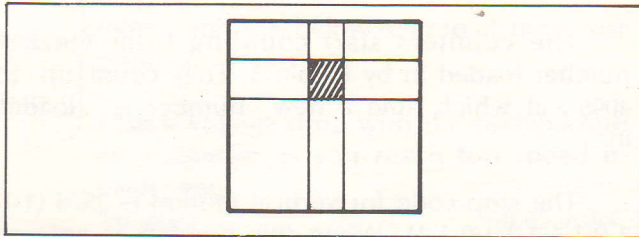

Figure 2-25b Complete Window

at the 256th half-line down from the top of the screen and the lower half of the screen is white. This is why it takes a *vertical* signal to define a horizontal line a certain *vertical* distance down the CRT.

If we create a similar line, except 128 half-lines down the CRT, the result will be a band 128 half-lines wide bounded at the top by 128V and at the bottom by 256V. This band is known as a horizontal window.

A complete window is created by generating a similar vertical window and gating the two windows together, so that we have an area with all four sides defined.

The video signals are gated with the window so that they can only appear when the window occurs. The result is that the video can then only appear within the window.

## 2.20 INTRODUCTION TO MOTION

The illusion of car motion is achieved by rapidly shifting the car image in the same way the illusion of motion is created on the motion picture screen by the film in the projector. The eye perceives this image shift as continuous motion because of a phenomenon known as *retinal after-image*. The last seen image is "remembered" for a short time, and as the position of the image is shifted a number of times in rapid succession, the eye "overlaps" the images and perceives the shifting process as continuous motion. Since the TV monitor has a frame rate of 30, it is possible to shift the car image so rapidly that the eye is completely fooled.

The speed or velocity of the car image is determined by the shift rate/frame rate ratio. If the image is shifted once every frame it will appear to move much faster than if it were shifted only once every three frames. The direction of the image is controlled by varying the rate at which the car image windows are shifted with respect to each other.

Notice the vertical motion window in Figure 2-26a. As this window moves up and down, the image contained within it also moves up and down. Figure 2-26b shows the horizontal motion window that controls how the image is shifted from left to right. When the two windows are combined, the image can be vectored at any angle by individually varying the rate each window is shifted.

The speed of the image is controlled by shifting the window with respect to sync. If the window frequency is the same as sync, it will be displayed in exactly the same place during each TV frame and it will appear stationary. However, if the window is generated a little slower or faster than sync, it will be shifted a certain amount each frame and will appear to move.

This is done by entering different binary codes at the parallel inputs to the 9316 counters of the motion circuits. The stop code is the binary number that times the window with sync and therefore stops motion. Other codes cause a change in this relationship, and the window is shifted with respect to sync.

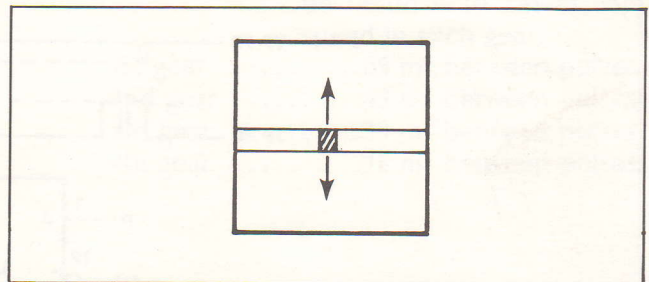

Figure 2-26a

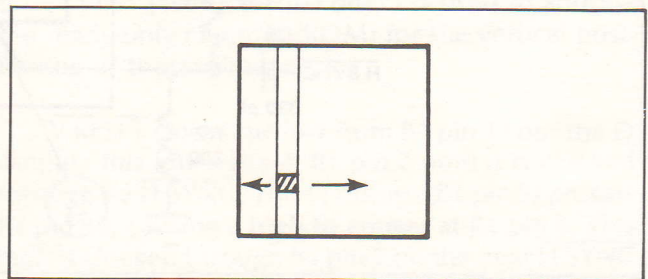

Figure 2-26b

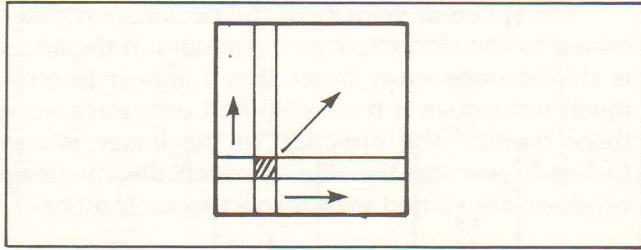

Figure 2-26

## 2.21 HORIZONTAL COUNT

H COUNT is used to clock counter J2 (vertical positioning for the car image) twice per line.

Capacitor C9 and resistors R1 and R2 create a very short reset pulse for both L1 flip-flops, and this produces a high at both  $\bar{Q}$  outputs. On the first 1H pulse, the  $\bar{Q}$  output at L1 pin 2 goes low, while L1 pin 3 goes high; the  $\bar{Q}$  at L1 pin 6 remains unchanged. On the second 1H pulse, L1 pin 2 goes high and L1 pin 6 goes low. On the 1H pulse, both L1 pin 2 and L1 pin 6 go low and stay low until both flip-flops are again reset by the capacitor and resistors.

### H COUNT TEST POINTS

TP 79: LOGIC PROBE: High and pulsing.  
OSCILLOSCOPE: See Figure 2-27.

TP 80: LOGIC PROBE: Low and pulsing.  
OSCILLOSCOPE: See Figure 2-27.

## 2.22 VERTICAL CAR MOTION

When  $\bar{V}Ld1$  is high, the ROM data is latched into H7 and appears at the outputs until  $\bar{V}Ld1$  drops low again. This information is loaded into the parallel inputs of J7 when the line from L5 pin 3 goes low.

The counters start counting from the last number loaded in by L5 pin 3. They count up to 4096, at which time a new number is loaded in.

The stop code for vertical motion is 3575 (1-1-0/1-1-1-1/1-0-1-1). When this number is entered into the counters, car motion ceases (4096 minus 3575 equals 521, which is the sync frequency).

However, as the least significant digits of the stop code are changed, the 9316s begin their count from a different number and the resulting car window frequency is changed. For example, if the number 0-1-1-0 is loaded into J7, the window will move down at the slowest velocity (4096 minus 3574 equals 522 which is slightly faster than sync).

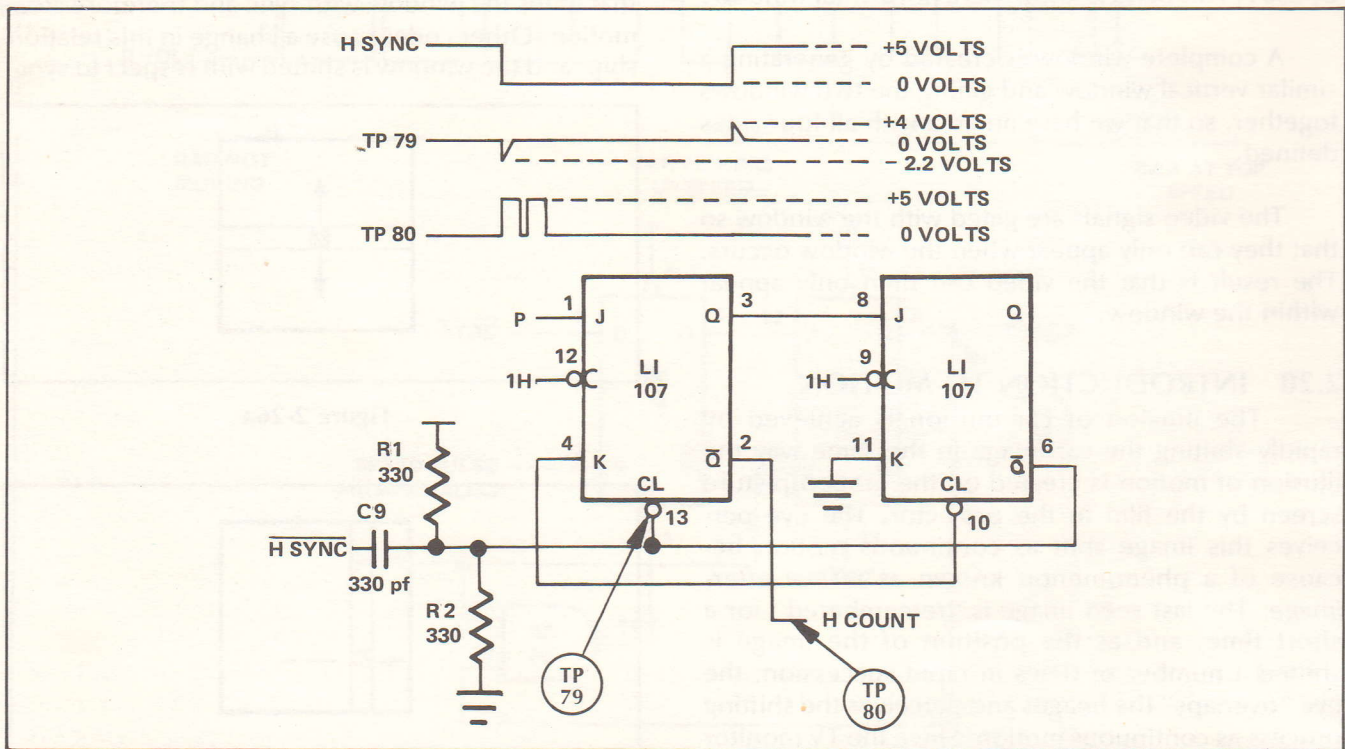

Figure 2-27 Horizontal Count Circuit and Waveforms

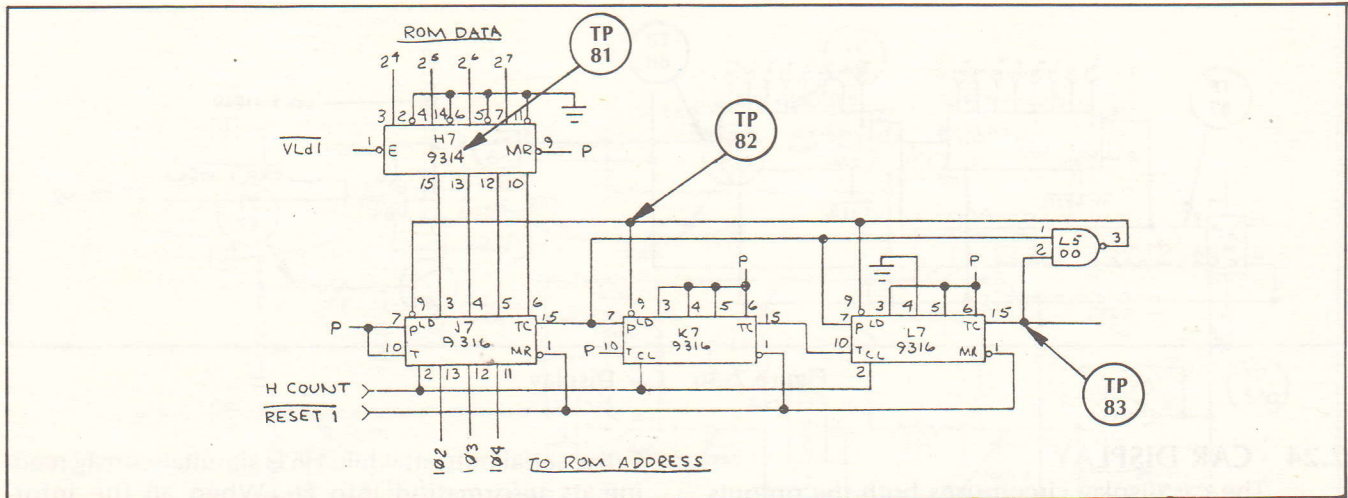

Figure 2-28 Vertical Car Motion

Notice the RESET 1 line which resets the car image at the start of the game or after the car has been driven off the track.

#### VERTICAL CAR MOTION TEST POINTS

- TP 81: Hold pin 1 of H7 low. Then using the oscilloscope or the logic probe, check to see if the input signals at pins 3, 4, 6 and 7 are reflected at output pins 15, 13, 12 and 10. NOTE: CRT images break up when you hold VLD1 low.
- TP 82: To check counters, first look at pins 9 with the video probe. You should see a thin black line that moves with the car and is parallel to the bottom edge of the CRT.

Then hold pins 9 low successively and check to see if the input signals of each counter (pins 3, 4, 5 and 6) are reflected at the outputs (pins 13, 12, 11 and 8).

- TP 83: VIDEO PROBE: At this test point, you will see the vertical car motion window appearing as a white horizontal band.

### 2.23 HORIZONTAL CAR MOTION

The only real differences between the horizontal and vertical motion circuits are that the horizontal counters are clocked by CLOCK rather than H COUNT, and that different numbers are loaded into the counters.

VLD1 is normally low and goes high once per field. During the time VLD1 is low, the stop code 0-0-0-1 is loaded into E7. When VLD1 goes high, the ROM data is entered into E7 causing the horizontal motion window to shift.

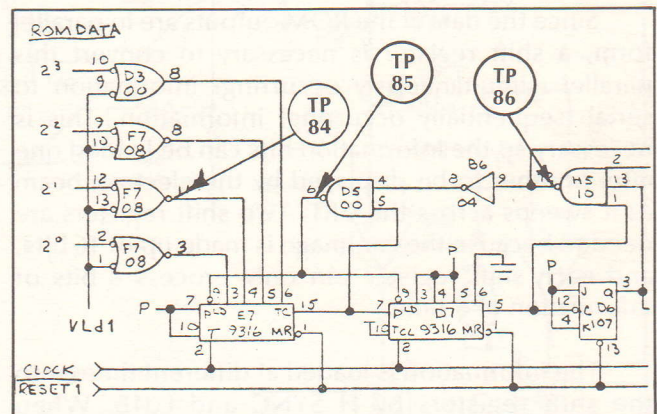

Figure 2-29 Horizontal Car Motion

#### HORIZONTAL MOTION TEST POINTS

- TP 84: Hold VLD1 low. This should generate the stop code 0-0-0-1 at pins 3, 4, 5 and 6 of E7. Then hold pins 9 of E7 and D7 low and the stop code should be reflected at output pins 14, 13, 12 and 11 of E7 and D7.
- TP 85: VIDEO PROBE: Thin black vertical line that moves with the car image.
- TP 86: VIDEO PROBE: The video probe will reveal the horizontal car motion window appearing as a black band moving with the car image.

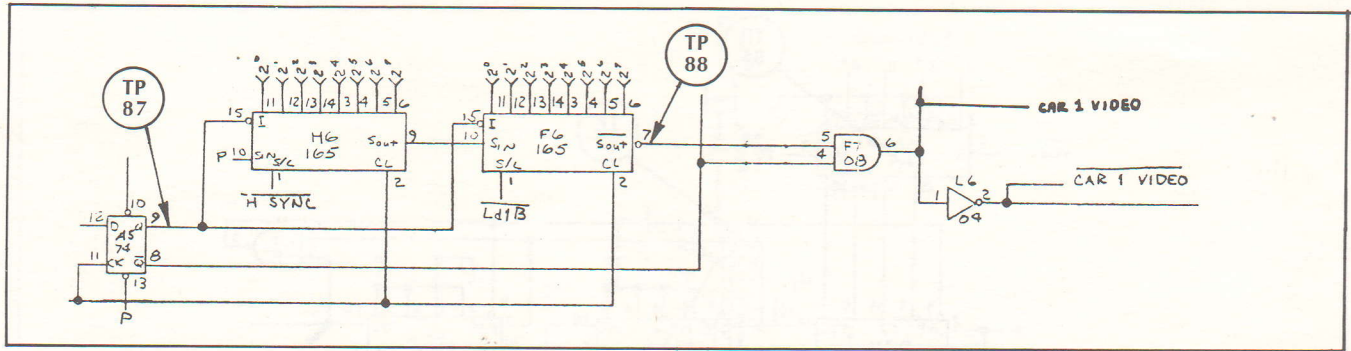

Figure 2-30 Car Display

## 2.24 CAR DISPLAY

The car display circuit uses both the outputs of the ROM and the outputs of the car motion circuits to generate the different aspects of the car image. The ROM supplies the necessary information for the car images; the car motion circuits move the car windows, and hence where the car image can appear. The display circuit displays all this information on the CRT.

Since the data at the ROM outputs are in parallel form, a shift register is necessary to convert this parallel (simultaneously occurring) information to serial (sequentially occurring) information. This is necessary so the information bits can be loaded one after another to be displayed by the electron beam as it sweeps across the CRT. Two shift registers are needed because the car image is made up of 16 bits, and each shift register can only process 8 bits of information at a time.

The information is loaded at different times into the shift registers by  $\overline{H SYNC}$  and Ld1B. When  $\overline{H SYNC}$  and Ld1B both go low, one set of car information is loaded into H6 by  $\overline{H SYNC}$  and the register latches up this information when  $\overline{H SYNC}$  returns high. Ld1B is still low and another set of car information is loaded into F6 and latched up when Ld1B returns high.

As long as the clock inhibit (I) of a shift register is high, the information remains latched in the register. However, when input I goes low, the clock pulses at pin 2 read out the information serially. The clock inhibit goes low during the car window signal which comes from the Q output of A5. The car window is the intersection of the vertical and horizontal car motion windows.

Thus, when the inhibit inputs of the registers go low, F6 reads out its latched-up information out pin

7 (the serial output) while H6 is simultaneously reading its information into F6. When all the information originally stored in F6 is read out F6 pin 7; F6 then reads out the information read into it by H6. All this information is gated with the car window at F7 to form CAR 1 VIDEO—the final car image signal.

### CAR DISPLAY TEST POINTS

- TP 87: VIDEO PROBE: Black square superimposed over car image.
- TP 88: VIDEO PROBE: A number of horizontal white lines covering CRT from top to bottom. One or two of these lines intersect the car image and stop at the car.

## 2.25 RACE TRACK DISPLAY

The information for the generation of the race track display is read out of the ROM, and this data is loaded into the parallel inputs of shift register E6 by RT CLOCK.

RT CLOCK is created at D3 by the gating of Ld1B with the modified 32H signal. The rising edge of 32H charges capacitor C38, which discharges through R54. It provides a very sharp high-going spike: there is also a low-going spike, but since it is below threshold voltage it cannot enable D3 and only the high-going spike is passed. This signal is gated with Ld1B, which allows only race track data to enter the shift register.

There are eight  $\overline{4H}$  pulses for every RT CLOCK pulse; the race track information is clock out E6 pin 9 serially by every 4H pulse.

The resulting signal contains both the race track and the score information. Since the score window is generated at a different time than when the score information is read out of the ROM, the score window (SCORE DISP) must be delayed at C3 by 32H so that the resulting score window occurs simultaneously with the score information and in the correct part of the CRT.

SPECIAL DATA prevents the race track data from being displayed when special information such as the finish line, the checkpoints and the score need to be displayed. Otherwise, race track images would be "written over" the special data. Whenever 2<sup>0</sup> and 2<sup>3</sup> go low and while 2<sup>1</sup> and Ld1B are high, the special data is clocked out 32H later.

The sizes of the pylons and the check points are determined by J1 and B3. This information is gated with SCORE DELAY at B3 and then with the race track and score information at C6 to form the complete race track signal (RT).

### RACE TRACK DISPLAY TEST POINTS

- TP 89: OSCILLOSCOPE: Frequency: 4.5  $\mu$ s; duration: 0.1  $\mu$ s. NOTE: No RT CLOCK pulse present when Ld1B goes low.
- TP 90: VIDEO PROBE: Vertical 4H bars covering screen from left to right. NOTE: Wider band in center is due to reset pulse.

- TP 91: VIDEO PROBE: All race track windows visible.
- TP 92: VIDEO PROBE: White windows over score and timer displays.
- TP 93: VIDEO PROBE: Dark check point, finish line and non-delayed score and timer windows.

### 2.26 TIME AND SCORE STORAGE

The primary functions of this circuit are to count the number of laps scored and the amount of elapsed time.

Laps are scored only by passing the race course checkpoints in proper order. If the check points are passed correctly, the lap score is increased by an increment of two. The information needed for generating the score images is contained within the ROM and read out by the following process.

The ROM data of the checkpoint location at the parallel inputs of E5 are loaded into that latch when RT CLOCK goes low and is latched when RT CLOCK goes back high.

The latched information enters the A and B inputs of the one-of-four decoders E3 and E4. The state of the E input controls the state of the selected output signal; the output signal is selected by the states of the A and B inputs. For example, if both A and B are low, output 0 will be selected; if E is low, the selected output 0 will also be low. If A is high and B

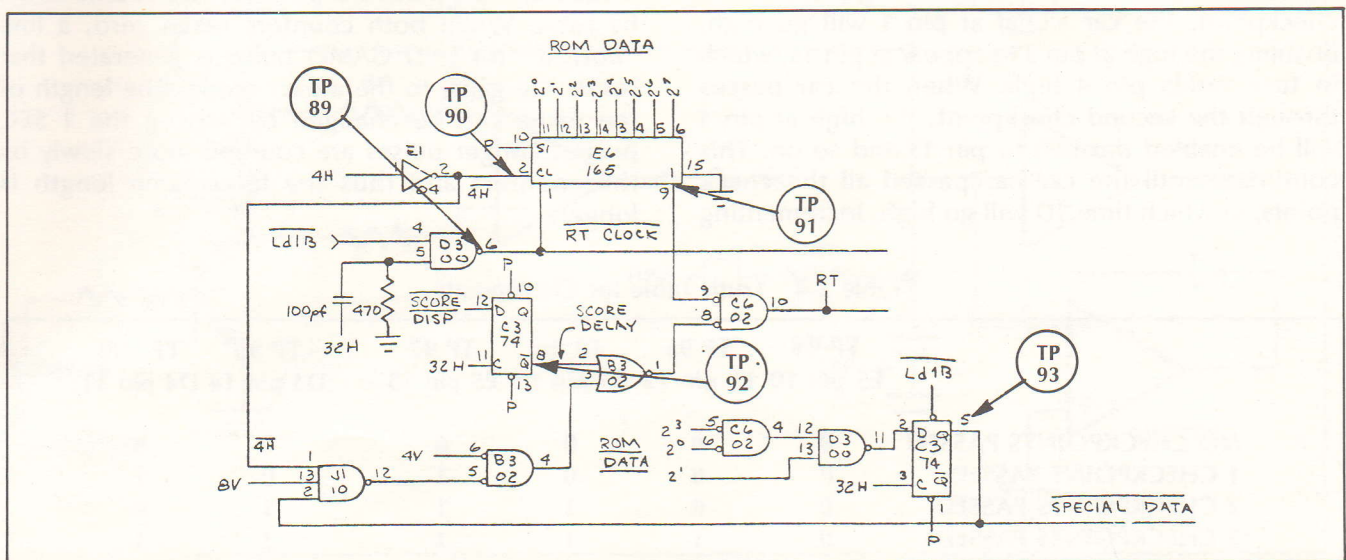

Figure 2-31 Race Track Display

is low, output 1 will be selected and if the E input is high, then output 1 will be high.

SPECIAL DATA (the signal from the race track display section containing the data for score display, oil slick, finish line and the checkpoints) is the E input to E4. Whenever SPECIAL DATA is low, the selected output of E4 will also be low.

For instance, when the checkpoint information is to be read out of the ROM, A will be low and B will be high. This selects output 2 which will be low because E (SPECIAL DATA) is also low. Output 2 then will contain all the checkpoint information, which is then sequentially selected by E3.

Output 0 of E4 is the finish line signal; however, it is 64 clock pulses wide—too wide for a functional finish line—so it is gated with RT CLOCK at B3. Since RT CLOCK is a spike of very short duration, the resulting finish line signal at B3 pin 13 will also be of very short duration and appear as a thin line. This thin finish line is then chopped into segments by gating it with 4V at A6 to give it a "dotted line" effect.

Laps are scored only by passing course checkpoints in the specified order: this is accomplished by selectively enabling latch F3. At the beginning of a new game, START goes high, clearing F3 so it can accept new information. Clearing F3 produces lows at pins 15, 13, 12 and 10 (1A, 1B, 1C and 1D); this causes lows to appear at pins 4, 6 and 7 and a high to appear at pin 3.

When the car passes through the first checkpoint, the car signal at pin 1 will go high, enabling the high at pin 3 to appear at pin 15, which in turn holds pin 4 high. When the car passes through the second checkpoint, the high at pin 4 will be enabled through to pin 13 and so on. This continues until the car has passed all the checkpoints, at which time 1D will go high, incrementing

counter F4 and simultaneously returning a low to pin 3. A low at pin 3 forces a low to appear at pin 15, which in turn causes pin 4 to be low. This then causes pin 13 to be low. This series continues until all the outputs are low and the latch is ready to record a new set of checkpoint and car image intersections.

The information at 1A, 1B, 1C and 1D must be converted to a binary code by gates A2, A3, D2 and E2 so that multiplexer D4 can correctly address the ROM score image information. The following truth table shows how this is accomplished.

D4 is a quad two-to-one multiplexer that selects either the score storage information or the game timer information. The signal is selected by 512H, and the outputs of the multiplexer (B, C, D and E) become inputs to the ROM multiplexers. Basically, these outputs tell the ROM what number to look up and read out for the score and timer number images stored within the ROM.

The ROM only stores 39 sets of number display information (the even numbers from 0-78) which limits the numbers which can be displayed for the score and game timer. The score will count up to 78 and the game timer counts down from 78.

C4 is the ones counter for the game timer and B4 is the tens counter. When START goes low, these counters begin counting down from the number loaded into the parallel inputs (78) and counts down by twos. When both counters reach zero, a low "borrow" (or END GAME) pulse is generated that resets the game to the attract mode. The length of the game can be changed by varying the 1 SEC pulses. Longer pulses are counted more slowly by the counters and thus the total game length is longer.

Table 2-4 Truth Table for Checkpoints

	TP 94 E5 pin 10	TP 95 E5 pin 12	TP 96 E5 pin 13	TP 97 E5 pin 15	TP 99 D4 pin 14	TP 100 D4 pin 11
NO CHECKPOINTS PASSED	0	0	0	0	0	0
1 CHECKPOINT PASSED	0	0	0	1	0	1
2 CHECKPOINTS PASSED	0	0	1	1	1	0
3 CHECKPOINTS PASSED	0	1	1	1	1	1
4 CHECKPOINTS PASSED	1	1	1	1	0	0

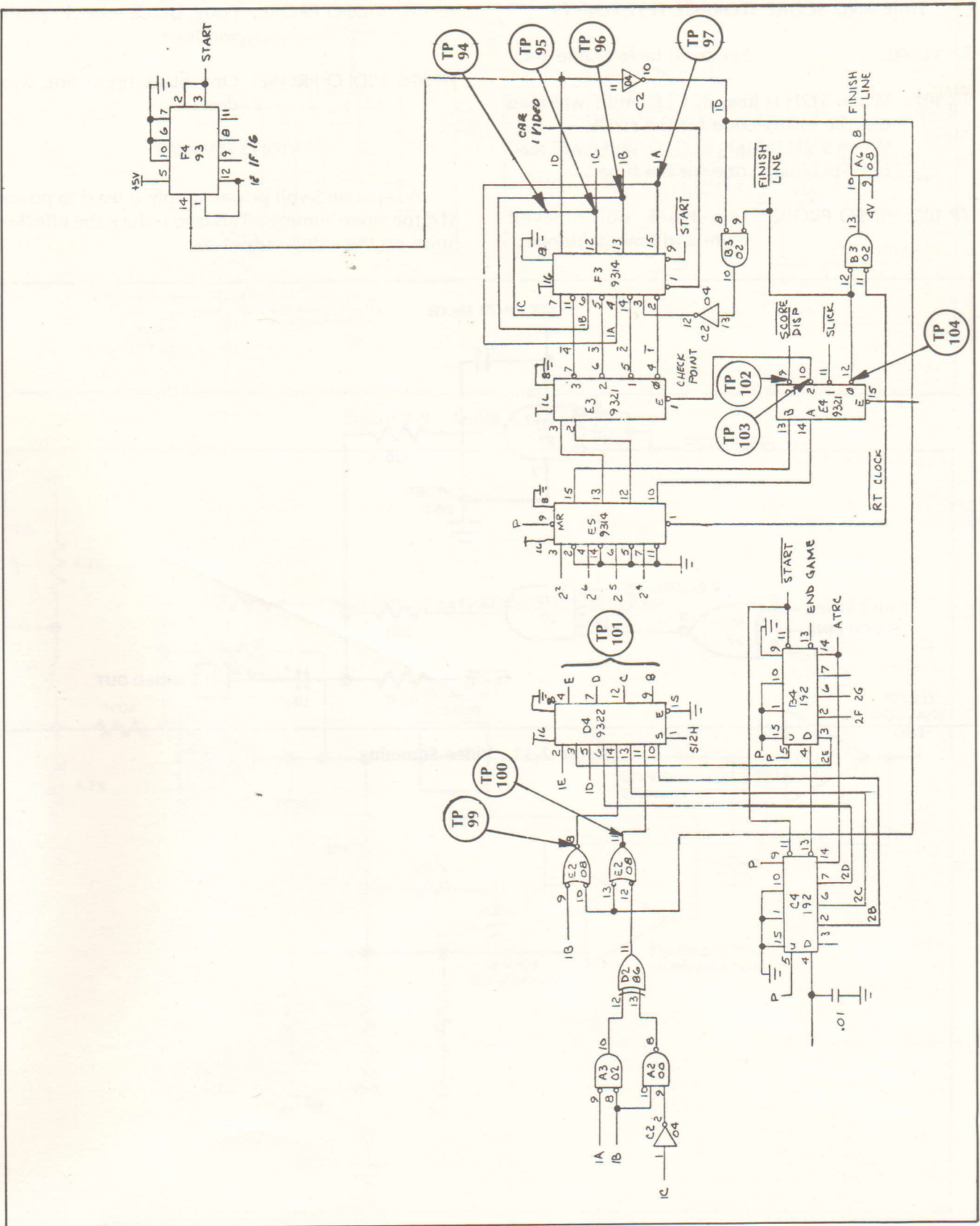

Figure 2-32 Time and Score Storage

### TIME AND SCORE STORAGE TEST POINTS

TP 94-100: See truth table (Table 2-4).

TP 101: When 512H is low, B, C, D and E will read out the binary code for the score.  
When 512H is high, B, C, D, and E will read out the binary code for the timer.

TP 102: VIDEO PROBE: Two black non-delayed score and timer windows.

TP 103: VIDEO PROBE: Four black check point windows.

TP 104: VIDEO PROBE: One black finish line window.

### VIDEO SUMMER

A separate 5-volt power supply is used to power M7, the video summer. This is to reduce the effect of noise on the video output.

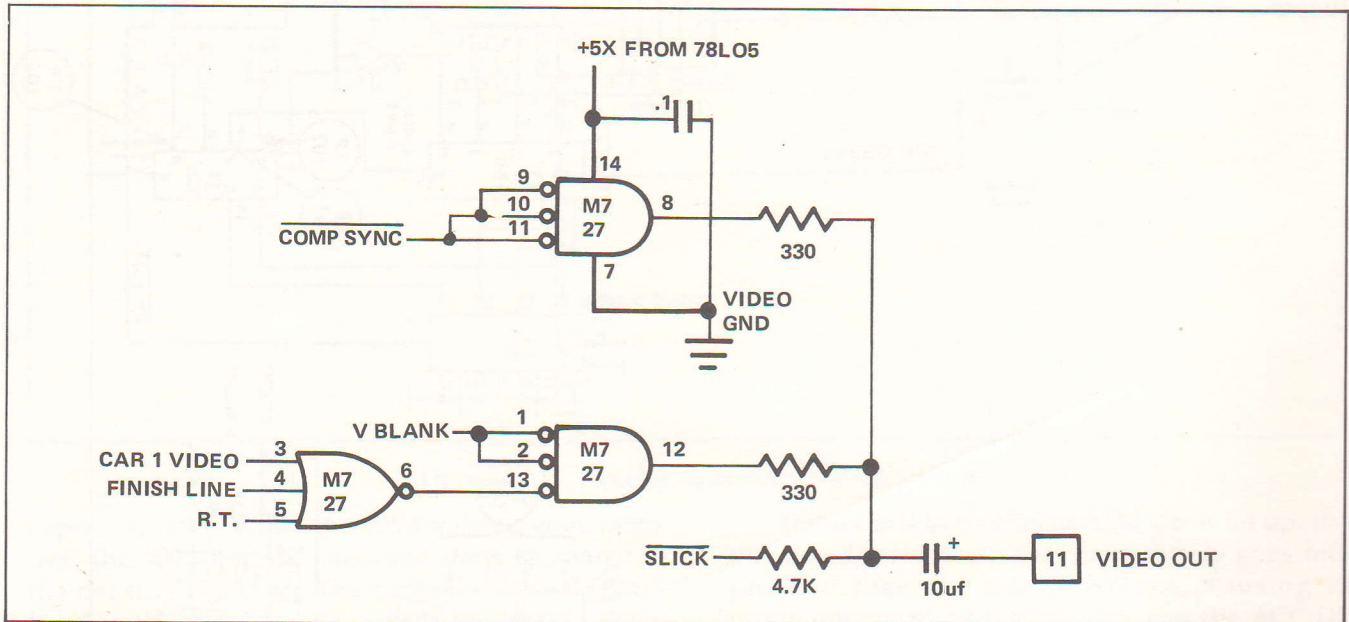
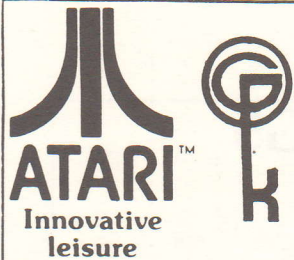

Figure 2-33 Video Summing

### III. SCHEMATICS, DRAWINGS AND PARTS LISTS

Number	Title
A005886	Parts List and Drawing Top Assembly
A005884	Parts List and Drawing Control Panel Assembly
A005882	Parts List and Drawing Double Foot Pedal Mounting Assembly
005904	Schematic Harness Wiring
A005885	Parts List and Drawing Electronics Tray Assembly
A005844	Schematic, Parts List and Assembly Printed Circuit Board
(none)	Schematic Motorola XM501/701 Monitor

LEMANS



ASSEMBLY TITLE / ASSY - TOP CABINET

P/L A005886

## PARTS LIST SPECIFICATION

Page 1 of 1

Drawn

Checked

Mech. Eng.

Proj. Eng

Elec. Eng

REV.  
C

MF

Rev.	Description	Date	Apprv.	Rev.	Description	Date	Apprv.
A		4/25/76					
B	Rev per ECN 2782	6/28/76					
C	Rev per ECN 2812	7/6/76					

Item	Part Number	Qty.	DESCRIPTION
1	A005862-02	1	Cabinet Assy with Graphics
2	A005884	1	Control Panel Assy
3	A005882	1	Metal Foot Pedal Assy
4	A005430	1	Display Assy
5	A005883	1	Sliding T.V. Shelf Assy
6	A005912-02	1	R.F. Shielding Enclosure Assy
7	A004132-XX	1	R.F. Shield P.C. Assy
8	A005844	1	P.C.B. Assy, Lemans
9	A005885	1	Electronics Tray Assy
10	A003637-11	1	Coin Door Assy
11	003053	2	Retainer, Plex
12	75-99090006	6	Weldnuts #10-32
13	82-8016	6	Screws, Mach. THD., Allen Socket, Button Hd, #10-32 x 1"
14	005892	1	Lite Box Plexiglas with Graphics
15	005378-02	1	Playfield Plexiglas with Graphics
16	005894	1	Bezel, Cardboard with Graphics
17	005419	1	Speaker Grill, Cover
18	73-77004	4	Rivets, 3/16 x .68 Long
19	75-5524B	2	Carriage Bolts, 1/4-20 x 1 1/2
20	75-015S	2	Washers, Flat 1/4
21	75-045	5	Washers, Split Lock 1/4-20
22	72-6808	1	Screw, S.M. #8 x 1/2 Phil., Pan. Hd.
23	72-5524	1	Screw, Mach., Hex Hd., Stl. Cd. Plate 1/4-20 x 1 1/2 Lg.
24	72-6824	4	Screws, Sheet Metal #8 x 1 1/2, Phil, Pan Hd.
25	72-6812	6	Screw, Sheet Metal #8 x 3/4, Phil, Pan Hd.
26	75-5124B	6	Carriage Bolts, #10-24 x 1 1/2
27	75-010S	6	Flat Washers, #10
28	75-040	6	Lock Washers, #10-24
29	75-911S	6	Hex Nuts, #10-24
30	002728	2	Mntg. Brkt, Control Panel
31	75-935	4	Wing Nuts #1/4-20
32	A005898	1	Light Shield Assy
33	72-6610	4	Screw, S.M. #6 x 5/8, Phil. Pan Hd.
34	TM-077	1	Technical Manual
35	A005901-XX	1	Shipping Container
36	005233	1	Rear Door Seal
37	82-1824	10	Screws, Wood, #8 x 1 1/2, Flat Hd. Phil.
38	A005906	1	Rear Door Assy
39	78-6601216	A/R	Aluminum Foil (appx 2 ft)
40	005908	1	Extended Play Score Card



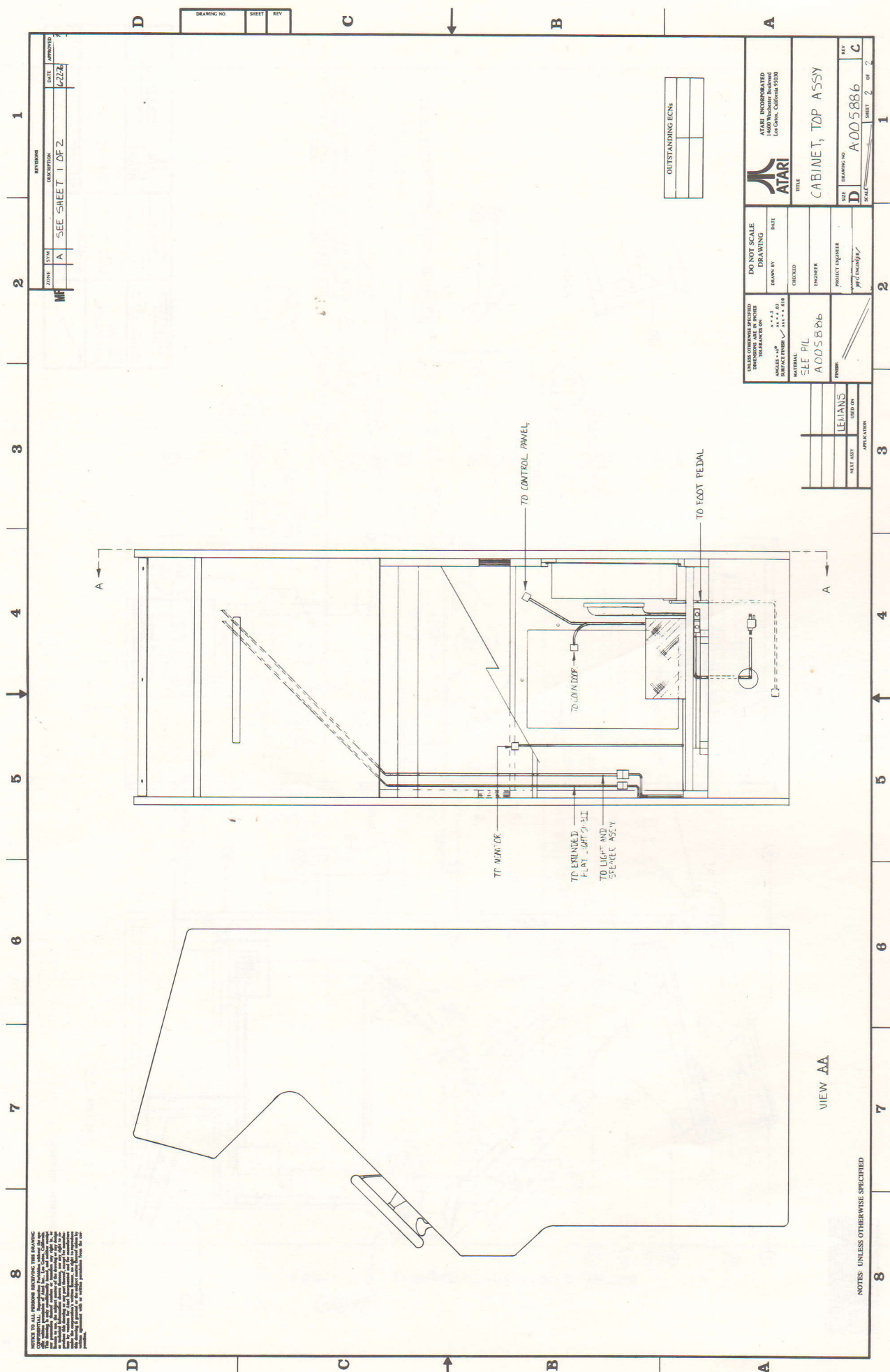

DRAWING IS NOT TO BE REPRODUCED OR TRANSMITTED IN ANY FORM OR BY ANY MEANS, ELECTRONIC OR MECHANICAL, INCLUDING PHOTOCOPYING, RECORDING, OR BY ANY INFORMATION STORAGE AND RETRIEVAL SYSTEM, WITHOUT THE WRITTEN PERMISSION OF ATARI INCORPORATED. ALL RIGHTS ARE RESERVED. THIS DRAWING IS THE PROPERTY OF ATARI INCORPORATED AND IS LOANED TO YOU FOR YOUR USE ONLY. IT IS NOT TO BE REPRODUCED OR TRANSMITTED IN ANY FORM OR BY ANY MEANS, ELECTRONIC OR MECHANICAL, INCLUDING PHOTOCOPYING, RECORDING, OR BY ANY INFORMATION STORAGE AND RETRIEVAL SYSTEM, WITHOUT THE WRITTEN PERMISSION OF ATARI INCORPORATED.

NOTES: UNLESS OTHERWISE SPECIFIED

VIEW AA

OUTSTANDING ECNS	

		ATARI INCORPORATED 14400 NE 28th Street Redmond, Oregon 97056	
DO NOT SCALE DRAWING		DATE	
DRAWN BY		CHECKED	
INCHES		PROJECT NUMBER	
MATERIAL SEE P/L A 005886		PART NUMBER	
SEE P/L A 005886		USED ON	
PROJECT ENGINEER		DATE	
PROJECT NUMBER		DATE	
TITLE <b>CABINET, TOP ASSY</b>		SIZE (DRAWING IN)	
ATARI INCORPORATED		SHEET 2 OF 2	
DATE		REV C	

ZONE	SYM	DESCRIPTION	DATE	APPROVED
A		SEE SHEET 1 OF 2	4/22/76	

DRAWING NO.	SHEET	REV

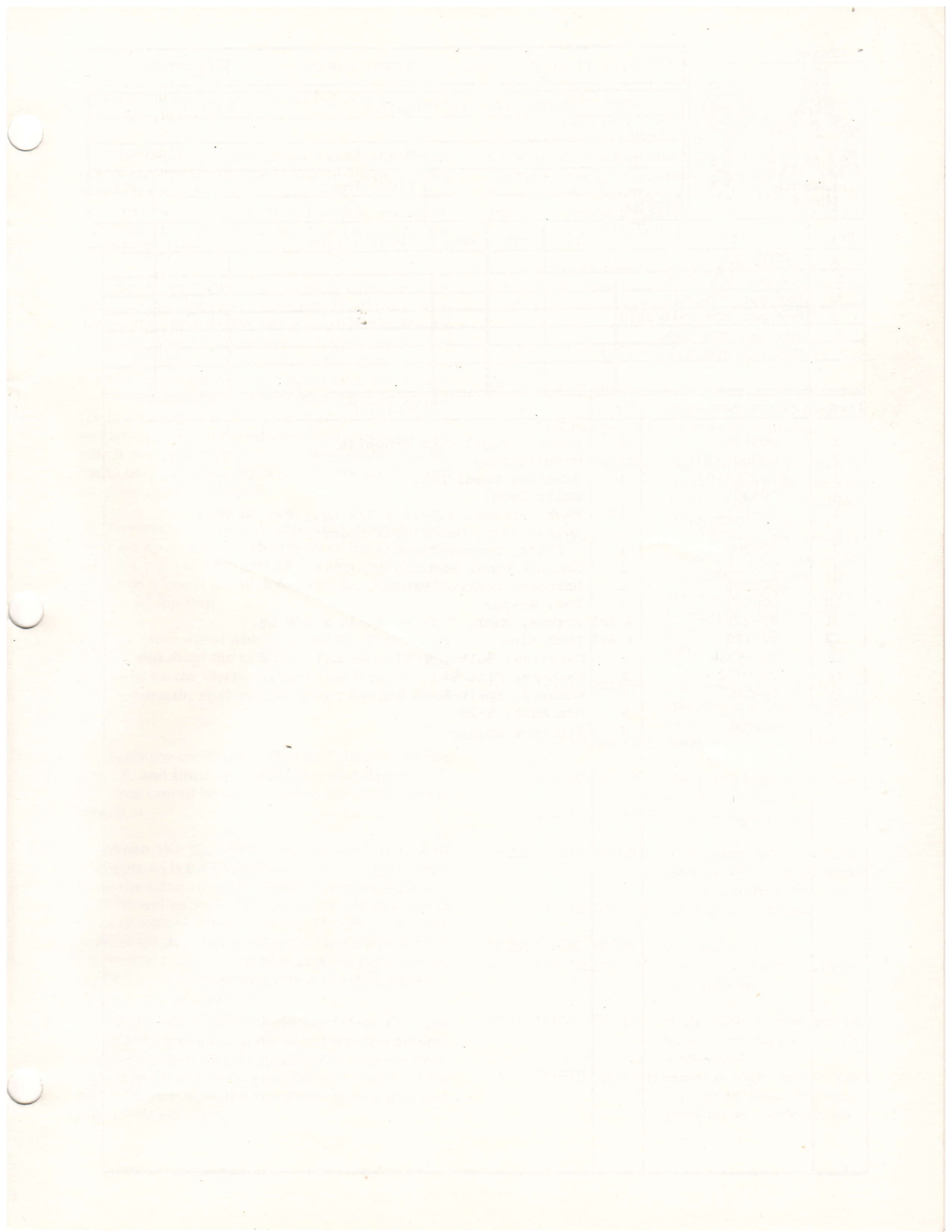

LEMANS



ASSEMBLY TITLE

ASSY - CONTROL PANEL

P/L A005884

## PARTS LIST SPECIFICATION

Page 1 of 1

Drawn

Checked

Mech. Eng.

Proj. Eng.

Elec. Eng

REV.

F

MFC

Rev.	Description	Date	Apprv.	Rev.	Description	Date	Apprv.
A	<b>PROD REL</b>						
B	Rev per ECN 2775						
C	Rev per ECN 2803						
D	Rev per ECN 2816/2819						
E	Rev per ECN 2896						
F	Rev per ECN 2919						

Item	Part Number	Qty.	DESCRIPTION
1	005850	1	Control Panel with Graphics
2	A000608-01	1	H-Shift Assy
3	A000598-03	1	Steering Wheel Assy
4	005255	1	Shift Bezel
5	72-1112S	10	Mach. Screws, #10-24 x 3/4 Lg., Pan Hd Phil
6	004304-07	1	Switch Assy, One Player Start
7	005889	1	Shift, Spacer Block
8	005907	1	Control Panel Support
9	A005896	1	Harness, Control Panel
10	000567	1	Bow, Washer
11	85-22F406	4 Ref	Screws, Mach. F Type, #4-40 x 3/8 Lg.
12	003178	1 Ref	Lock Ring
13	75-5524B	2	Carriage, Bolts, 1/4-20 x 1 1/2 Lg.
14	75-015S	2	Washers, Flat 1/4
15	75-045	2	Washers, Split-Lock 1/4
16	75-915S	2	Hex Nuts, 1/4-20
17	75-040	4	#10 Lock Washer

NOTES TO ALL PERSONS RECEIVING THIS DRAWING:  
 1. THIS DRAWING IS THE PROPERTY OF ATARI INC. AND IS NOT TO BE REPRODUCED OR TRANSMITTED IN ANY FORM OR BY ANY MEANS, ELECTRONIC OR MECHANICAL, INCLUDING PHOTOCOPYING, RECORDING, OR BY ANY INFORMATION STORAGE AND RETRIEVAL SYSTEM, WITHOUT THE WRITTEN PERMISSION OF ATARI INC. IN THE EVENT OF DISCOVERY OF THIS DRAWING BY ANY OTHER PARTY, IT IS TO BE KEPT SECRET AND NOT TO BE DISCLOSED TO ANY OTHER PARTY.  
 2. THIS DRAWING IS THE PROPERTY OF ATARI INC. AND IS NOT TO BE REPRODUCED OR TRANSMITTED IN ANY FORM OR BY ANY MEANS, ELECTRONIC OR MECHANICAL, INCLUDING PHOTOCOPYING, RECORDING, OR BY ANY INFORMATION STORAGE AND RETRIEVAL SYSTEM, WITHOUT THE WRITTEN PERMISSION OF ATARI INC. IN THE EVENT OF DISCOVERY OF THIS DRAWING BY ANY OTHER PARTY, IT IS TO BE KEPT SECRET AND NOT TO BE DISCLOSED TO ANY OTHER PARTY.  
 3. THIS DRAWING IS THE PROPERTY OF ATARI INC. AND IS NOT TO BE REPRODUCED OR TRANSMITTED IN ANY FORM OR BY ANY MEANS, ELECTRONIC OR MECHANICAL, INCLUDING PHOTOCOPYING, RECORDING, OR BY ANY INFORMATION STORAGE AND RETRIEVAL SYSTEM, WITHOUT THE WRITTEN PERMISSION OF ATARI INC. IN THE EVENT OF DISCOVERY OF THIS DRAWING BY ANY OTHER PARTY, IT IS TO BE KEPT SECRET AND NOT TO BE DISCLOSED TO ANY OTHER PARTY.

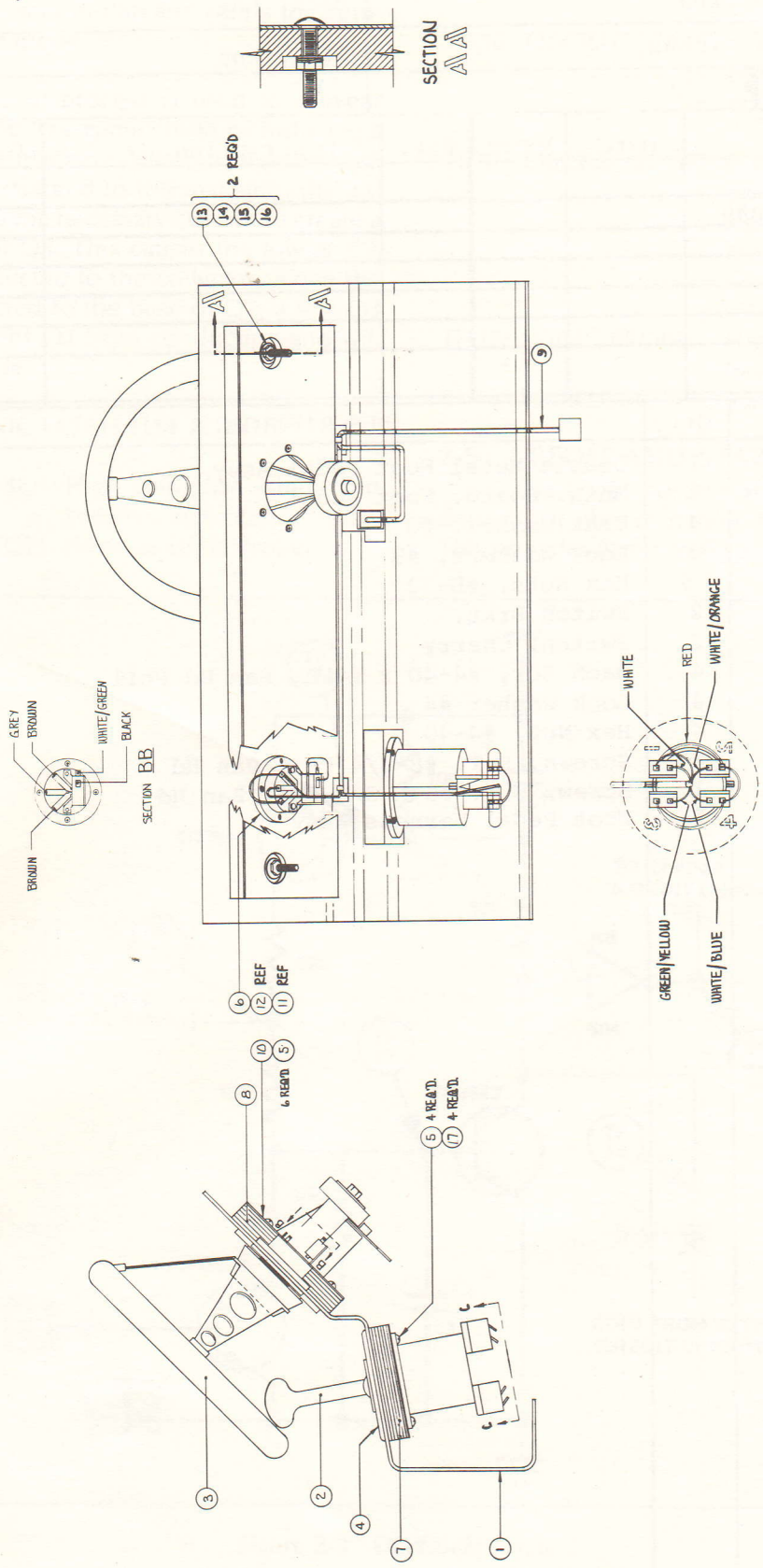

ATARI INCORPORATED 1400 THE ARCADE LOS GATOS, CALIFORNIA 95030		TITLE <b>ASSY, CONTROL PANEL</b>	
DO NOT SCALE DRAWING	DATE	CHECKED	ENGINEER
PROJECT ENGINEER	MFG. ENGINEER	SIZE <b>D</b>	DRAWING NO. <b>A 005884-01</b>
SHEET <b>1</b>	OF <b>1</b>	REV <b>F</b>	

NOTES: UNLESS OTHERWISE SPECIFIED



ASSEMBLY TITLE / ASSY - FOOT PEDAL MOUNTING P/LA005882

PARTS LIST SPECIFICATION		Page 1 of 1
Drawn		
Checked	Mech. Eng.	
Proj. Eng.	Elec. Eng	
<b>ME</b>	REV. B	

Rev.	Description	Date	Apprv.	Rev.	Description	Date	Apprv.
A							
B	REV. PER ECN 2849						

Item	Part Number	Qty.	DESCRIPTION
1	A004798	1	Double Metal Foot Pedal Assy
2	004801	1	Mntg. Board, Foot Pedal
3	75-018S	4	Flat Washer, #8
4	75-048	4	Lock Washers, #8
5	75-918S	5	Hex Nuts, #8-32
6	002191	2	Switch Brkt.
7	65-071C	2	Switch, Cherry
8	72-1412S	4	Mach Scr, #4-40 x 3/4"Lg Pan Hd Phil
9	75-044	4	Lock Washer #4
10	75-914S	4	Hex Nut, #4-40
11	72-6812	4	Screws, S.T. #8-3/4 Phil Pan Hd
12	72-6612	1	Screw, S.T. #6 x 3/4 Phil Pan Hd
13	A005900	1	Foot Pedal Harness Assy

NOTICE TO ALL PERSONS RECEIVING THIS DRAWING  
 CONFIDENTIAL - Atari Corporation. This drawing is the property of Atari Corporation and is to be used only for the purpose specified. It is to be held in confidence and not to be distributed, copied, or otherwise used without the written consent of Atari Corporation. The design and/or appearance of the subject matter shown in this drawing is granted to the subject matter shown in this drawing by Atari Corporation. Atari Corporation, 14600 Winchester Boulevard, Los Gatos, California 95030.

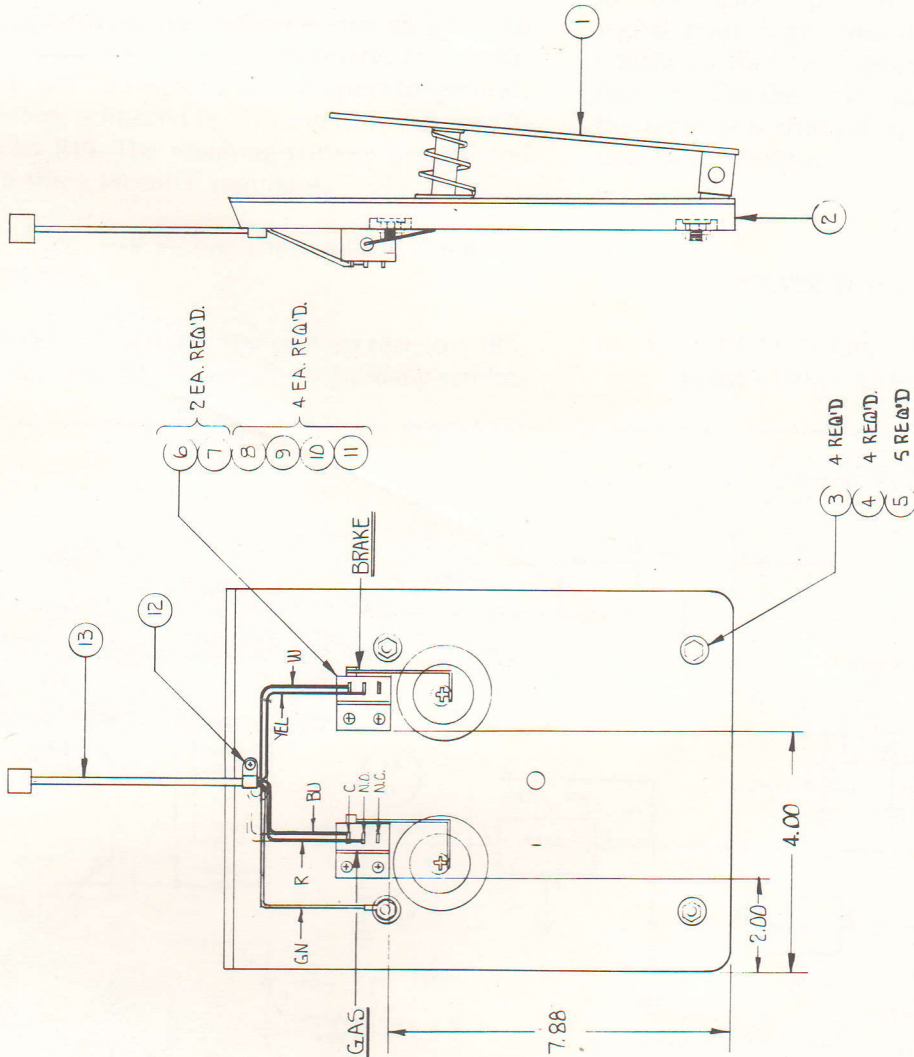

CURRENT VERSION -01

 ATARI INCORPORATED 14600 Winchester Boulevard Los Gatos, California 95030		TITLE <b>DOUBLE FOOT PEDAL          MNTG. ASSY</b>	
DO NOT SCALE DRAWING	DRAWN BY DATE	CHECKED ENGINEER	PROJECT ENGINEER MFG ENGINEER
UNLESS OTHERWISE SPECIFIED DIMENSIONS ARE IN INCHES TOLERANCES ON: .5 - .1 .1 - .03 ANGLES - .1° SURFACE FINISH ✓ .0008 A.R. 0.10		MATERIAL: SEE P/L A00 5882	
FINISH:		SIZE <b>C</b>	DRAWING NO. <b>A00 5882</b>
SHEET 1 OF 1		REV <b>B</b>	

NOTES: UNLESS OTHERWISE SPECIFIED



NOTICE TO ALL PERSONS RECEIVING THIS DRAWING: This drawing is the property of Atari Inc., Los Gatos, California. It is to be used for the manufacture of the Atari 2600 console or transfer any right in or to the same. No part of this drawing is to be reproduced, stored in a retrieval system, or transmitted in any form or by any means, electronic, mechanical, photocopying, recording, or by any information storage and retrieval system, without the prior written agreement with or written permission from the corporation.

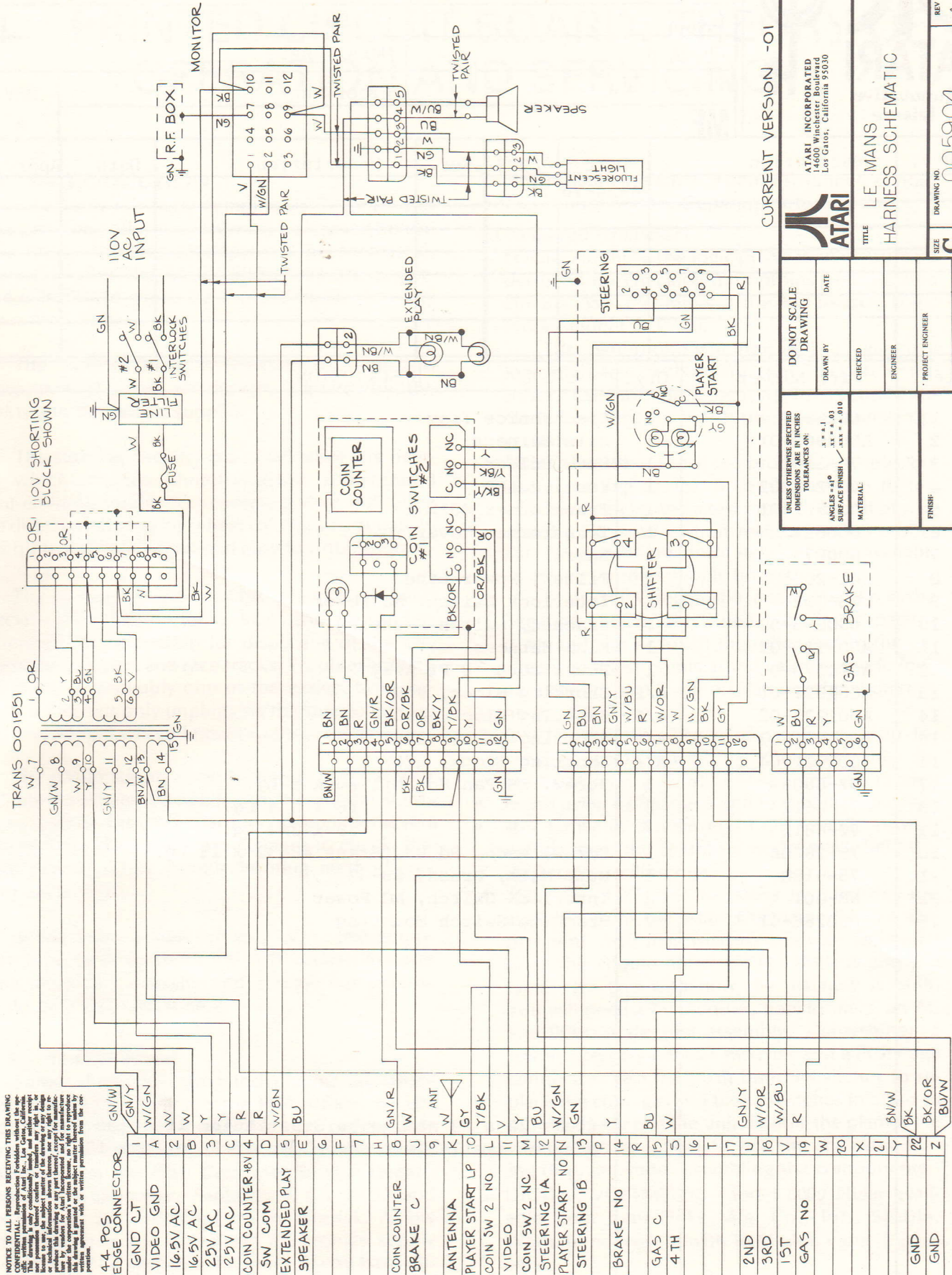

CURRENT VERSION -01

<p>ATARI INCORPORATED 14600 Winchester Boulevard Los Gatos, California 95030</p>		<p>REVISION</p> <p>REV A</p>	
<p>DO NOT SCALE DRAWING</p> <p>DATE</p>		<p>SCALE</p> <p>SHEET 1 OF 1</p>	
<p>UNLESS OTHERWISE SPECIFIED DIMENSIONS ARE IN INCHES</p> <p>ANGLES ±.10</p> <p>SURFACE FINISH ±.0005 ±.010</p>		<p>TITLE</p> <p>LE MANS HARNESS SCHEMATIC</p>	
<p>DRAWN BY</p> <p>CHECKED</p> <p>ENGINEER</p> <p>PROJECT ENGINEER</p> <p>MFG. ENGINEER</p>		<p>DRAWING NO.</p> <p>005904</p>	
<p>MATERIAL</p> <p>FINISH</p>		<p>SIZE</p> <p>C</p>	

NOTES : UNLESS OTHERWISE SPECIFIED

LE MANS



ASSEMBLY TITLE / ELECTRONICS TRAY ASSY

P/LA005885-01

## PARTS LIST SPECIFICATION

Page 1 of 1

Drawn

Checked

Mech. Eng.

Proj. Eng.

Elec. Eng.

REV.

A

MF

Rev.	Description	Date	Apprv.	Rev.	Description	Date	Apprv.
A		6-24-76					

Item	Part Number	Qty.	DESCRIPTION
1	002621	1	Electronics Tray
2	A005903-01	1	Main Harness
3	79-3201	1	Fuse Holder
4	46-201202	1	Fuse, 2 AMP
5	001551-01	1	Transformer 001551
6	000622	1	Transformer Cover
7	000871	1	Label
8	41-2001	1	Filter, Power Line
9	68-002	1	Interlock Switch, AC Power
10	000268-02	1	Bracket, Switch Mounting
11	A005926-01	1	Mini Harness
12	A004576-05	1	Power Cord, 8 Ft Assy
13	A001921-01	A/R	Shorting Block, 95V
14	A001921-02	A/R	Shorting Block, 110V
15	A001921-03	A/R	Shorting Block, 220V H
16	A001921-04	A/R	Shorting Block, 220V L
17*	72-6608	3	Screw, SM Pan Hd Phil #6 x 1/2 Lg.
18	72-6612	5	" " " " " #6 x 3/4 Lg.
19	72-6812	7	" " " " " #8 x 3/4 Lg.
20	75-2820B	1	Screw, Mach, Rd Hd, Brass #8-32 x 1 1/4 Lg.
21	75-918B	1	Nut, Mach, Brass, #8-32
22*	68-001	2	Interlock Switch, AC Power
23*	000268-01	2	Bracket, Switch Mounting

\*Items 22 & 23 are to be Substituted if Items 9 & 10 are not available & add a Qty of 2 to Item 17

NOTE TO ALL PERSONS RECEIVING THIS DRAWING  
 CONSULT THE DRAWING FOR THE LOCATION OF THE  
 CIFIC WITHIN PERMITS OF ATARI INC., LOS GATOS, CALIFORNIA  
 THIS DRAWING IS THE PROPERTY OF ATARI INC. AND IS NOT TO BE  
 REPRODUCED OR TRANSMITTED IN ANY FORM OR BY ANY MEANS  
 WITHOUT THE WRITTEN PERMISSION OF ATARI INC. ANY UNAUTHORIZED  
 REPRODUCTION OR TRANSMISSION OF THIS DRAWING IS STRICTLY  
 PROHIBITED. THE INFORMATION CONTAINED HEREIN IS UNCLASSIFIED  
 EXCEPT WHERE SHOWN OTHERWISE. ANY UNAUTHORIZED REPRODUCTION  
 OR TRANSMISSION OF THIS INFORMATION IS STRICTLY PROHIBITED.  
 UNDER THE COMPANION'S WRITTEN PERMISSION, NO RIGHT TO REPRODUCE  
 THIS DRAWING OR THE INFORMATION CONTAINED HEREIN IS GRANTED  
 WITHOUT THE WRITTEN PERMISSION OF ATARI INC.

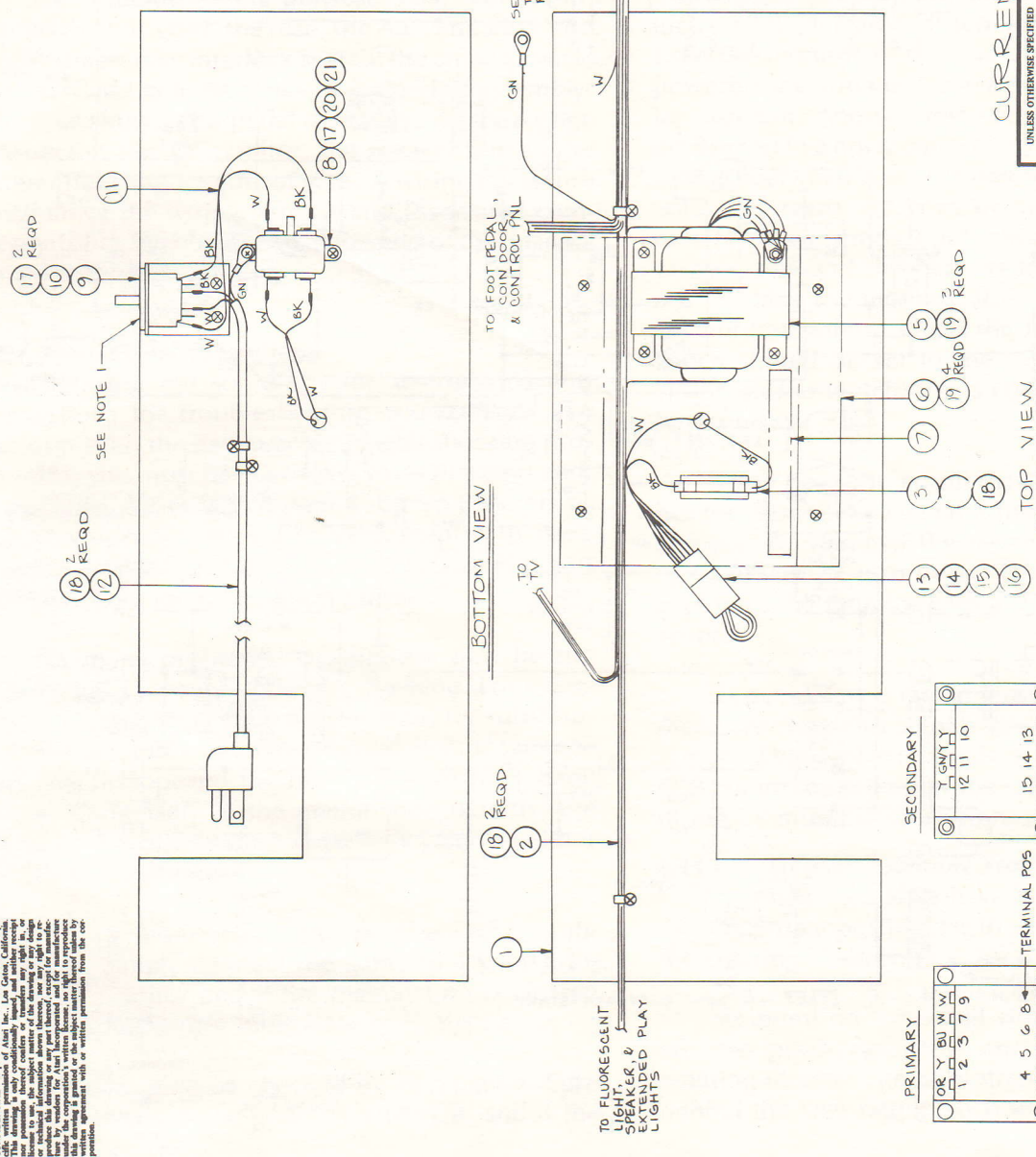
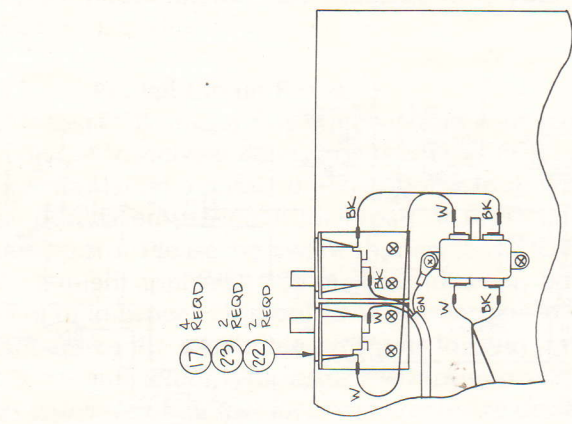

PRIMARY

OR	Y	BU	W	W	W	W	W
1	2	3	4	5	6	7	9

TERMINAL POS

GN	BK	V	GN/W
----	----	---	------

SECONDARY

Y	GN/Y	W	W	W	W	W	W
12	11	10	15	14	13	12	11

GN BK GN/W

NOTES

1. SHOWN IS THE PREFERRED INTERLOCK SWITCH & MOUNTING BRACKET. IT IS NOT TO BE USED WITH THE MOUNTING BRACKET AS SHOWN IN SKETCH A.

CURRENT VERSION - 01

ATARI INCORPORATED 14600 Winchester Boulevard Los Gatos, California 95030		TITLE <b>LE MANS ELECTRONICS TRAY ASSEMBLY</b>		SIZE <b>C</b>	DRAWING NO. <b>A005885</b>	REV <b>A</b>
DO NOT SCALE DRAWING		DATE		SCALE <b>1:2</b>		SHEET <b>1</b> OF <b>1</b>
UNLESS OTHERWISE SPECIFIED DIMENSIONS ARE IN INCHES TOLERANCES ON:		DRAWN BY		CHECKED		PROJECT ENGINEER
ANGLES $\pm 10^\circ$ SURFACE FINISH $\sqrt{\text{XXX}} \pm 0.010$		ENGINEER		MFG ENGINEER		REVISIONS
MATERIAL:		FINISH:		PROJECT ENGINEER		MFG ENGINEER

NOTES : UNLESS OTHERWISE SPECIFIED

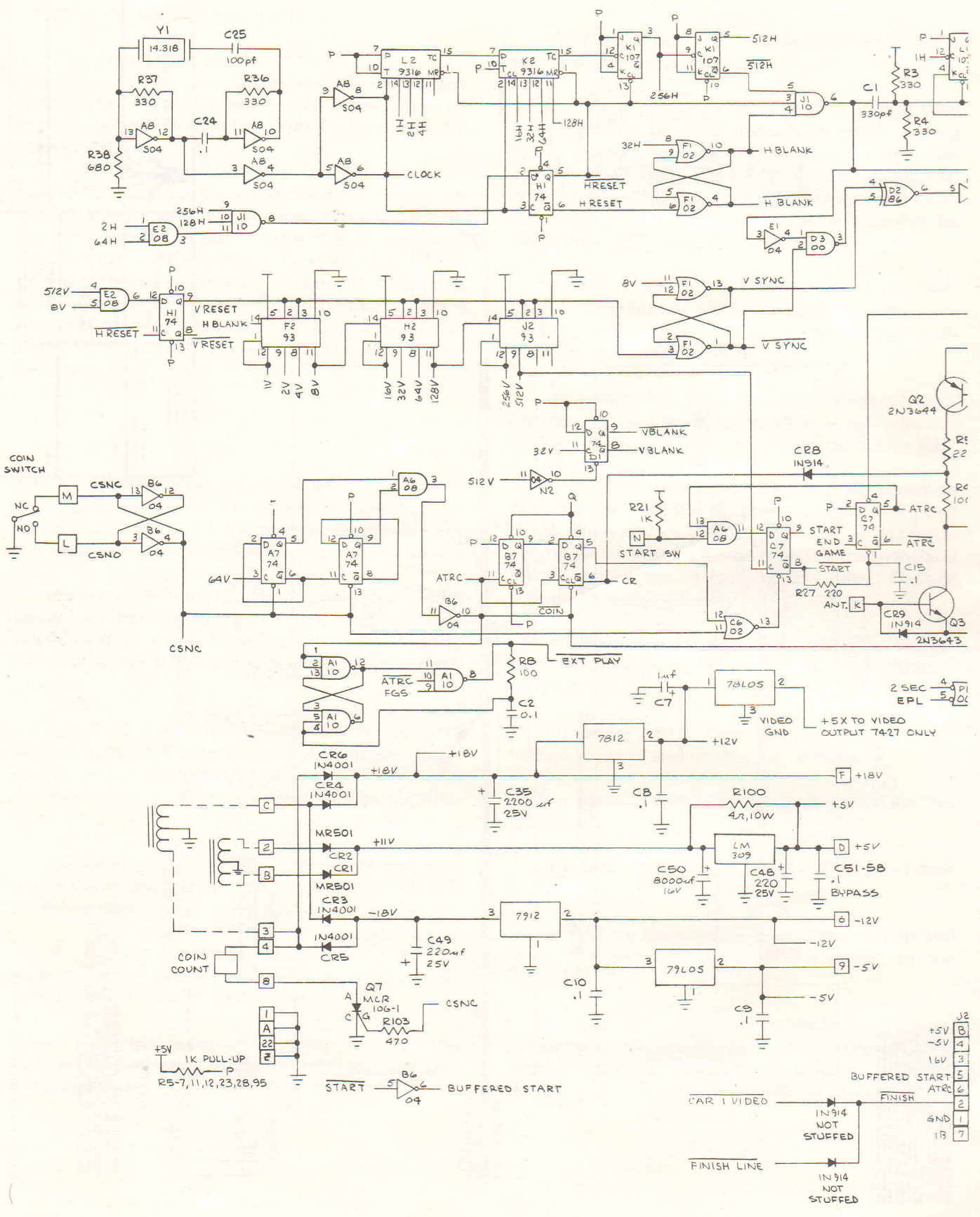

COIN SWITCH

+5V 1K PULL-UP  
R5-7,11,12,23,28,95

START 5 04 BUFFERED START

FINISH LINE IN914 NOT STUFFED

J2  
+5V B  
-5V 4  
16V 3  
5 5  
GND 1  
1B 7

2 SEC 4 PI  
EPL 5 Q

+5X TO VIDEO OUTPUT 7427 ONLY

VIDEO GND  
+12V  
+5V  
-12V  
-5V

FINISH LINE IN914 NOT STUFFED

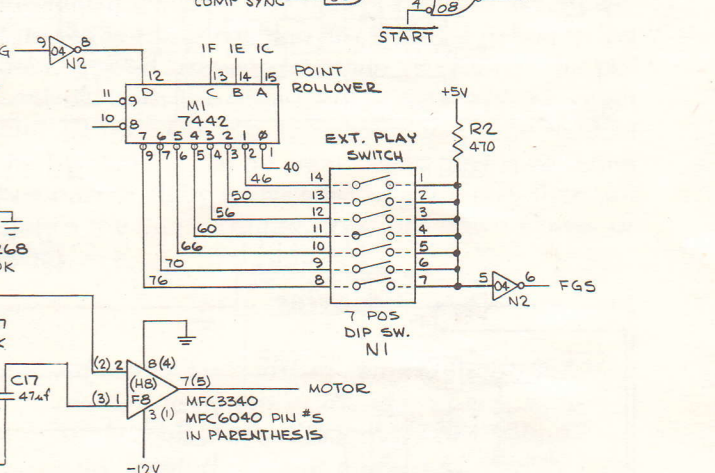
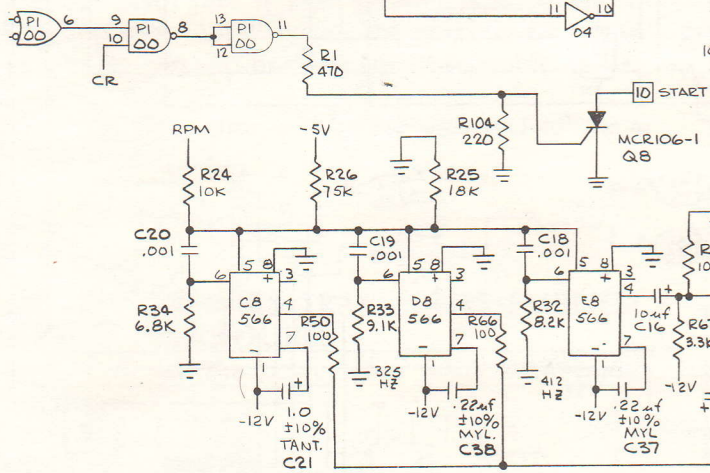
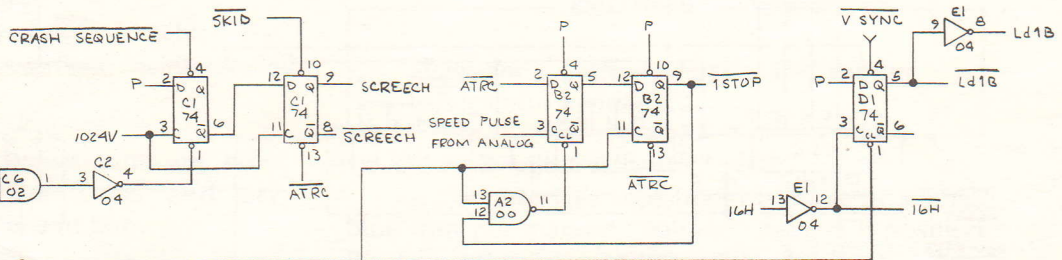
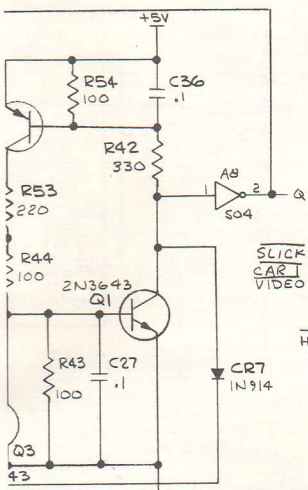
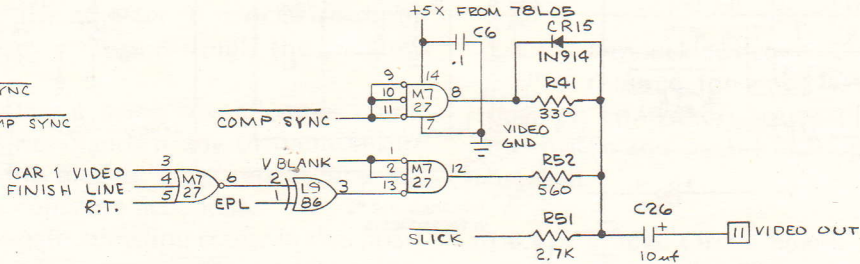
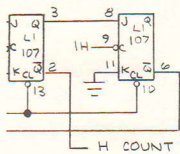

INTERPRET THIS DRAWING PER USASI Y14.5  UNLESS OTHERWISE SPECIFIED DIMENSIONS ARE IN INCHES TOLERANCES ON:  FRACTIONS = ±1/16 x .1 ANGLES = ±1° x .03 SURFACE FINISH = ±.010  MATERIAL:	DRAWN BY _____ DATE _____	 ATARI INCORPORATED 14600 Winchester Boulevard Los Gatos, California 95030	
	CHECKED _____		TITLE SCHEMATIC, LE MANS
	DESIGN ENGINEER _____		PROJECT ENGINEER _____
	DOCUMENT CONTROL _____		APPROVED _____
MOTOR MFC3340 MRC6040 PIN #S IN PARENTHESES		SIZE <b>D</b> DRAWING NO. 005844-01 REV <b>C</b>	
SCALE _____		SHEET 1 OF 3	

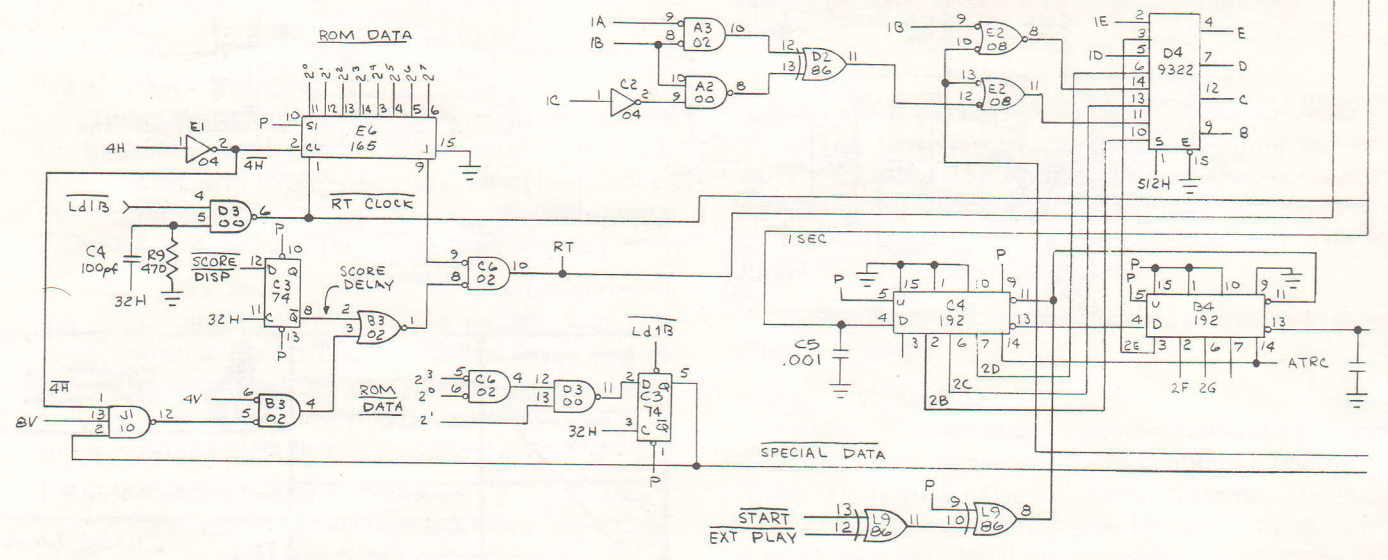
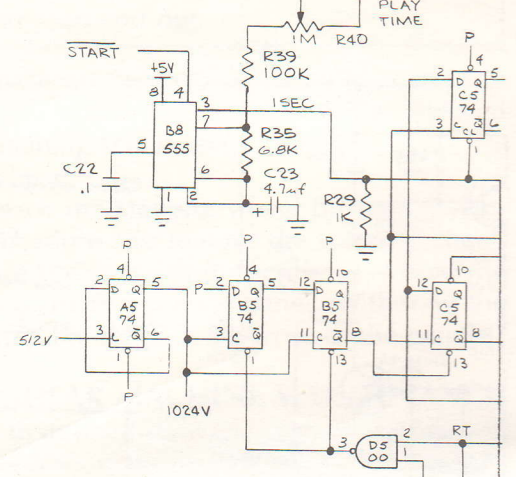
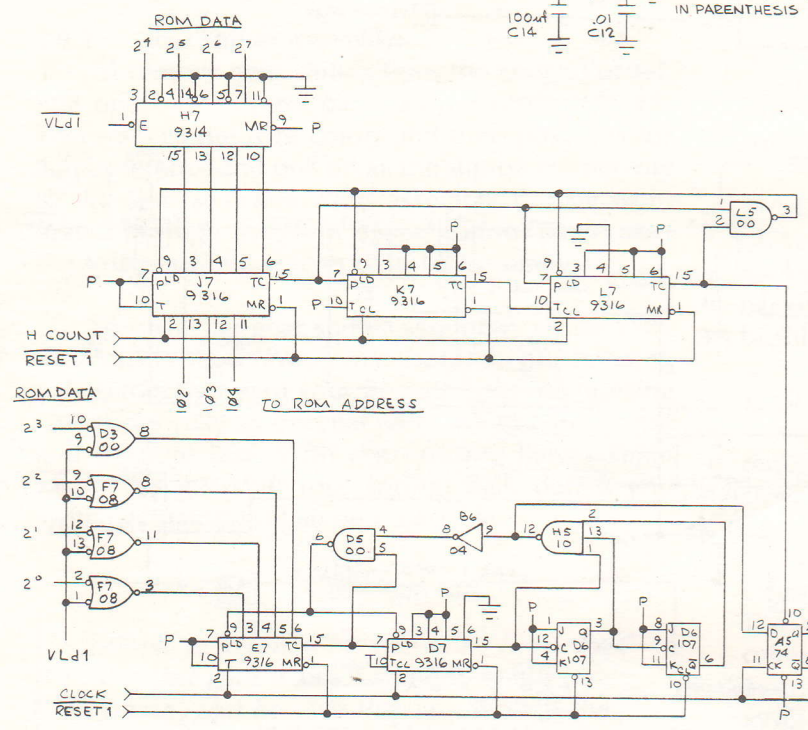
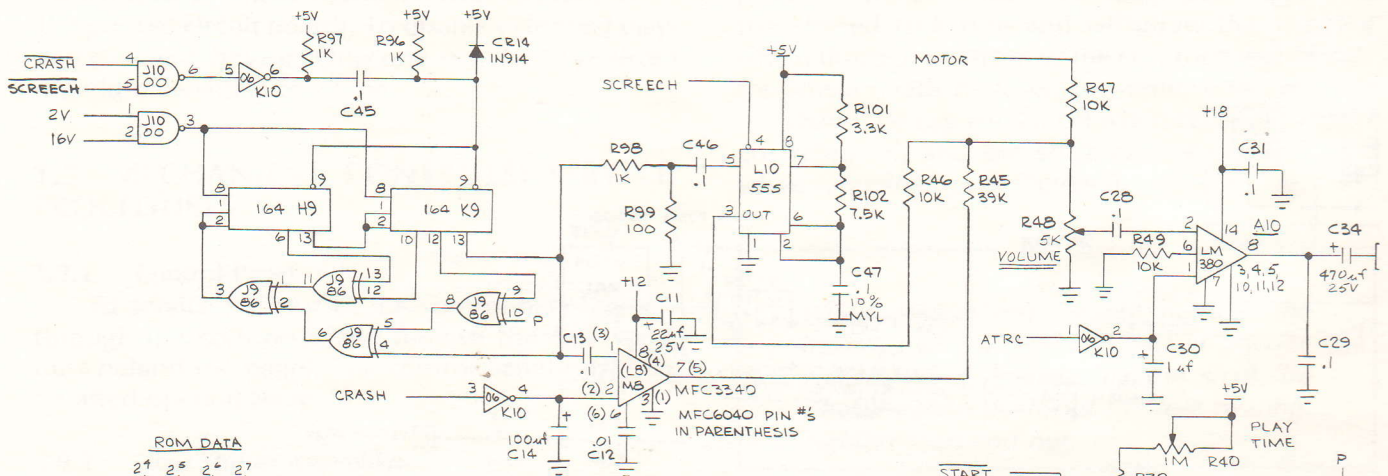

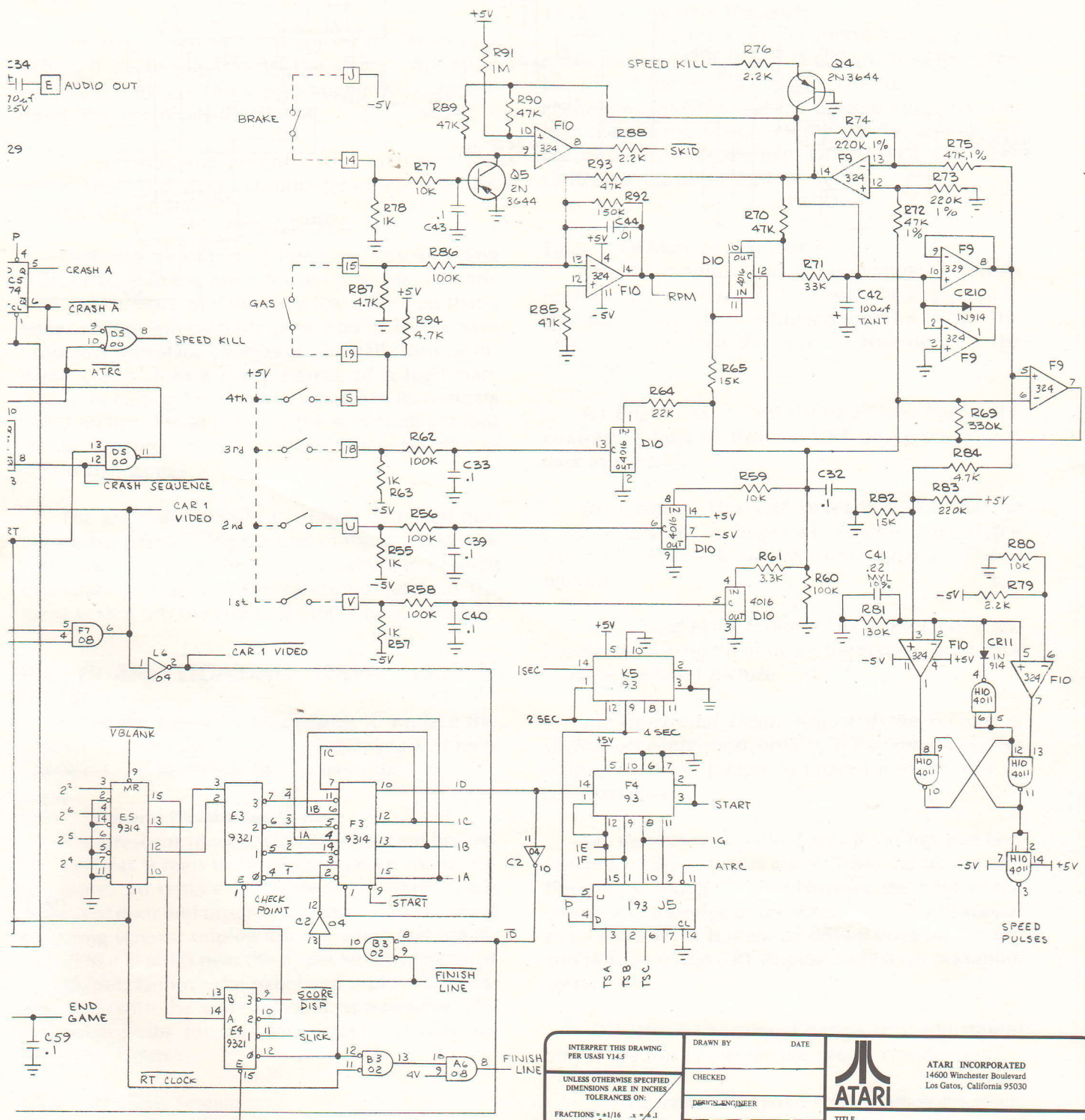

NOTICE TO ALL PERSONS RECEIVING THIS DRAWING  
 CONFIDENTIAL: Reproduction Forbidden without the specific written permission of Atari Inc., Los Gatos, California. This drawing is only conditionally loaned and neither receipt nor possession thereof confers or transfers any right in, or license to use, the subject matter of the drawing or any design or technical information shown thereon, nor any right to reproduce this drawing or any part thereof, except for manufacture under the corporation's written license, no right to reproduce this drawing is granted or the subject matter hereof unless by written agreement with or written permission from the corporation.

INTERPRET THIS DRAWING PER USASI V14.5	DRAWN BY _____ DATE _____	 ATARI INCORPORATED 14600 Winchester Boulevard Los Gatos, California 95030
UNLESS OTHERWISE SPECIFIED DIMENSIONS ARE IN INCHES TOLERANCES ON:	CHECKED _____	
FRACTIONS = +1/16 .x = 4.1 ANGLES = 41° .xx = .03 SURFACE FINISH = .xxx = .010	DESIGN/ENGINEER _____	
MATERIAL: _____	PROJECT ENGINEER _____	
	DOCUMENT CONTROL _____	TITLE
	APPROVED _____	SCHMATIC LE MANS
SIZE <b>D</b>	DRAWING NO. 005844-01	REV <b>C</b>
SCALE -		SHEET 2 OF 3

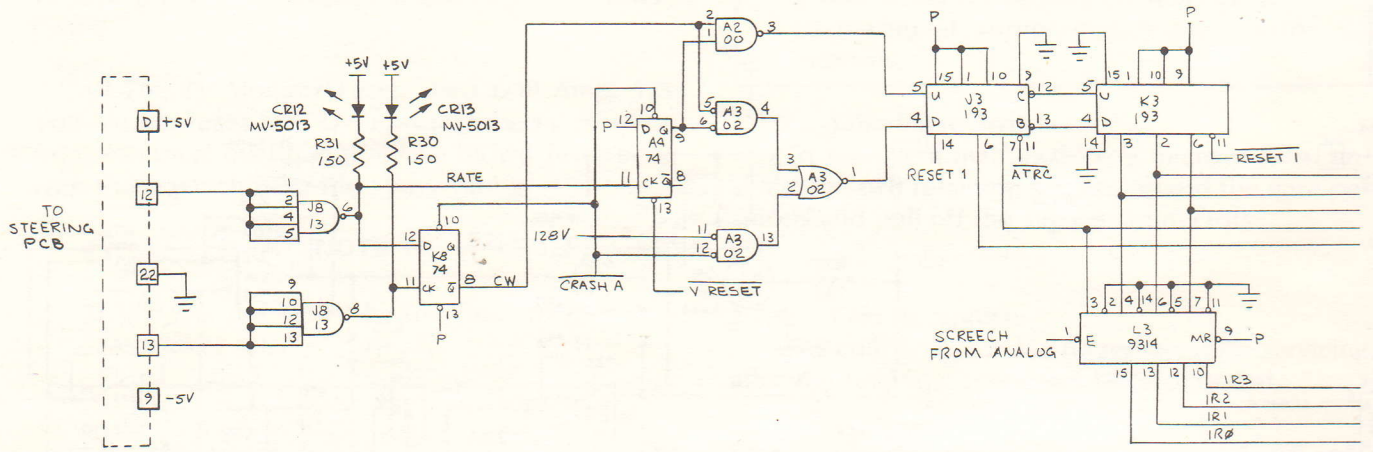

2 SEC -

TSB -

EXT PL

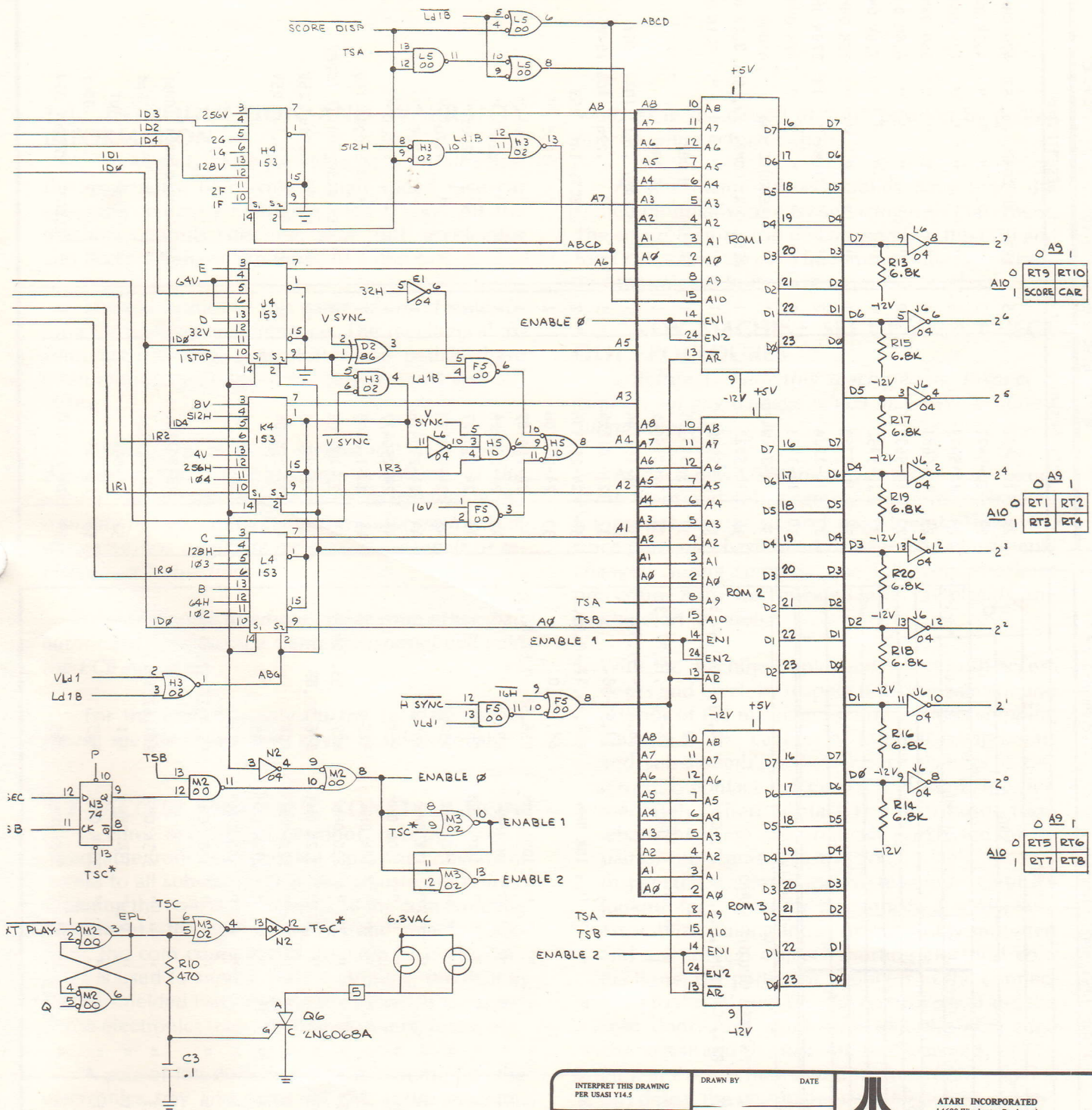

NOTICE TO ALL PERSONS RECEIVING THIS DRAWING  
 CONFIDENTIAL: Reproduction Forbidden without the specific written permission of Atari Inc., Los Gatos, California. This drawing is only conditionally issued, and neither receipt nor possession thereof confers or transfers any right in, or license to use, the subject matter of the drawing or any design or technical information shown thereon, nor any right to reproduce this drawing or any part thereof, except for manufacture by vendors for Atari Incorporated and for manufacture under the corporation's written license, no right to reproduce this drawing is granted or the subject matter licensed unless by written agreement with or written permission from the corporation.

INTERPRET THIS DRAWING PER USASI Y14.5	DRAWN BY _____ DATE _____	 ATARI INCORPORATED 14600 Winchester Boulevard Los Gatos, California 95030
UNLESS OTHERWISE SPECIFIED DIMENSIONS ARE IN INCHES TOLERANCES ON: FRACTIONS = ±1/16 .x = ±.1 ANGLES = ±1° .x = ±.03 SURFACE FINISH .xxx = ±.010	CHECKED _____ DESIGN ENGINEER _____ PROJECT ENGINEER _____ DOCUMENT CONTROL _____	
MATERIAL: _____	APPROVED _____	SIZE D
		DRAWING NO. 005844
		REV C
		SCALE _____ SHEET 3 OF 3



PARTS LIST SPECIFICATION

Drawn	
Checked	Mech. Eng.
Proj. Eng.	Elec. Eng.

Rev.	Description	Date	Apprv.	Rev.	Date	Apprv.
A	PROD. REL.					
B	REV PER ECN 2936,2937,2938,2943,2944,2945					
C	REV PER ECN 2958					

Item	Part Number	Qty.	DESCRIPTION
1	005845-01	1	PRINTED CIRCUIT BOARD
2	10-5101	7	RES, CAR.COMP, 1/4W,5% 100 OHM
3	10-5102	17	" " " " " 1K OHM
4	10-5103	8	" " " " " 10K OHM
5	10-5104	6	" " " " " 100K OHM
6	10-5105	1	" " " " " 1M OHM
7	10-5134	1	" " " " " 130K OHM
8	10-5151	2	" " " " " 150 OHM
9	10-5153	2	" " " " " 15K OHM
10	10-5154	1	" " " " " 150K OHM
11	10-5183	1	" " " " " 18K OHM
12	10-5221	3	" " " " " 220 OHM
13	10-5222	3	" " " " " 2.2K OHM
14	10-5223	1	" " " " " 22K OHM
15	10-5224	1	" " " " " 220K OHM
16	10-5561	1	" " " " " 560 OHM
17	10-5331	6	" " " " " 330 OHM
18	10-5332	3	" " " " " 3.3K OHM
19	10-5333	1	" " " " " 33K OHM
20	10-5334	1	" " " " " 330K OHM
21	10-5393	1	" " " " " 39K OHM

PARTS LIST SPECIFICATION

Item	Part Number	Qty.	DESCRIPTION
22	10-5471	5	RES, CAR COMP, 1/4W, 5% 470 OHM
23	10-5472	3	" " " " " 4.7K OHM
24	10-5473	5	" " " " " 47K OHM
25	10-5681	1	" " " " " 680 OHM
26	10-5682	10	" " " " " 6.8K OHM
27	10-5752	1	" " " " " 7.5K OHM
28	10-5753	1	" " " " " 75K OHM
29	14-1224	2	" " FILM " 1% 220K OHM
30	14-1473	2	" " " " " 47K OHM
31	19-808W4P0	1	" WIREWOUND 10w 4 OHM
32	10-5822	1	RES, CAR. COMP. 1/4W, 5%, 8.2K OHM
33	10-5912	1	" " " " " 9.1K OHM
34	19-315105	1	TRIMPOT 1M OHM
35	19-315502	1	" 5K OHM
36	21-101104	1	CAP, MYLAR, .1uf, 10% 100V
37	21-101224	3	" " .22uf, 10% 100V
38	24-250105	2	" ELECT, 1uf 25V
39	24-250106	2	" " 10uf "
40	24-250107	1	" " 100uf "
41	24-250226	1	" " 22uf "
42	24-250227	2	" " 220uf "
43	24-250475	1	" " 4.7uf "
44	24-250476	1	" " 47uf "
45	24-250477	1	" " 470uf "
46	24-160808	1	" " 8000uf 16V
47	27-102102	4	" CER DISC .001uf 1000V
48	27-250103	2	" " " .01uf 25V
49	27-250104	31	" " " 0.1uf 25V
50	28-101101	2	CAP. DIPPED MICA 100pf
51	28-101331	1	" " " 330pf
52	29-004	1	" TANT. 1uf
53	29-013	1	" " 100uf
54	24-250228	1	" ELECT 2200uf 25V

ASSEMBLY TITLE		P.C. BD. ASSY., LE MANS		P/L		A005844-01	
PARTS LIST SPECIFICATION		REV. C		DESCRIPTION		REV. C	
Item	Part Number	Qty.	DESCRIPTION				
55	10-5272	1	RES. CAR. COMP, 1/2W, 5% 2.7K OHM R51				
56	31-MR501	2	DIODE, POWER MR501				
57	31-IN914	7	" IN914				
58	31-IN4001	4	" IN4001				
59	38-MV5013	2	LED, RED MV5013				
60	33-2N3644	3	TRANSISTOR, 2N3644				
61	34-2N3643	2	" 2N3643				
62	35-MCR106-1	2	SCR, MCR106-1				
63	37-7400	8	I.C. 7400				
64	37-7402	6	" 7402				
65	37-7404	6	" 7404				
66	37-7404	6	" 7404				
67	37-7404	6	" 7404				
68	37-7404	1	" 7404				
69	37-7406	1	" 7406				
70	37-7408	3	" 7408				
71	37-7410	3	" 7410				
72	37-7413	1	" 7413				
73	37-7427	1	" 7427				
74	37-7442	1	" 7442				
75	37-7474	15	" 7474				
76	37-7486	3	" 7486				
77	37-7493	5	" 7493				
78	37-74107	3	" 74107				
79	37-74153	4	" 74153				
80	37-74164	2	" 74164				
81	37-74165	3	" 74165				
82	37-74192	2	" 74192				
83	37-74193	3	" 74193				
84	37-555	2	" 555				
85	37-566	3	" 566				
86	37-LM309	1	Regulator, LM 309				
87	37-LM324	2	IC LM324				
88	37-LM380	1	" LM380				
89	37-9314	4	" 9314				

ASSEMBLY TITLE		P.C. BD. ASSY., LE MANS		P/L		A005844-01	
PARTS LIST SPECIFICATION		REV. C		DESCRIPTION		REV. C	
Item	Part Number	Qty.	DESCRIPTION				
90	37-9316	7	I.C. 9316				
91	37-9321	2	" 9321				
92	37-9322	1	" 9322				
93	37-MFC6040	2	" MFC6040				
94	37-MFC3340	*2	" MFC3340				
95	37-4011	1	" 4011				
96	37-4016	1	" 4016				
97	37-78L05	1	+5V REG. 78L05				
98	37-7812	1	+12V REG. 7812				
99	37-79L05	1	-5V REG. 79L05				
100	37-7912	1	-12V REG. 7912				
101	66-117PIT	1	DIP SWITCH 7xSPST				
102	66-117PIT	1	DIP SWITCH 7xSPST				
103	78-16006	2	SILPAD ( TO-220)				
104	90-101	1	CRYSTAL, 14.318 MHZ				
105	78-06001	1	HEATSINK				
106	78-16005	1	SILPAD				
107	78-06010	2	HEATSINK,				
108	005837-01	1	ROM 1				
109	005838-01	1	ROM 2				
110	005839-01	1	ROM 3				
111	35-2N6068A	1	TRIAC, 2N6068A				
112	72-1608C	2	SCREW, MACH, PAN HD PHIL #6-32x1/2 CRES				
113	75-016S	2	WASHER, FLAT #6				
114	75-056	2	WASHER, INT. LOCK #6				
115	75-916C	2	NUT, HEX, #6-32 CRES				
116	72-1406C	3	SCREW, MACH PAN HD. PHIL #4-40x3/8 CRES				
117	75-014S	3	WASHER, FLAT #4				
118	75-054	3	WASHER, INT LOCK #4				
119	75-914C	3	NUT, HEX, #4-40 CRES				

\* NOTE: If item 93 (MFC6040) is not available, item 94 (MFC3340) may be substituted.



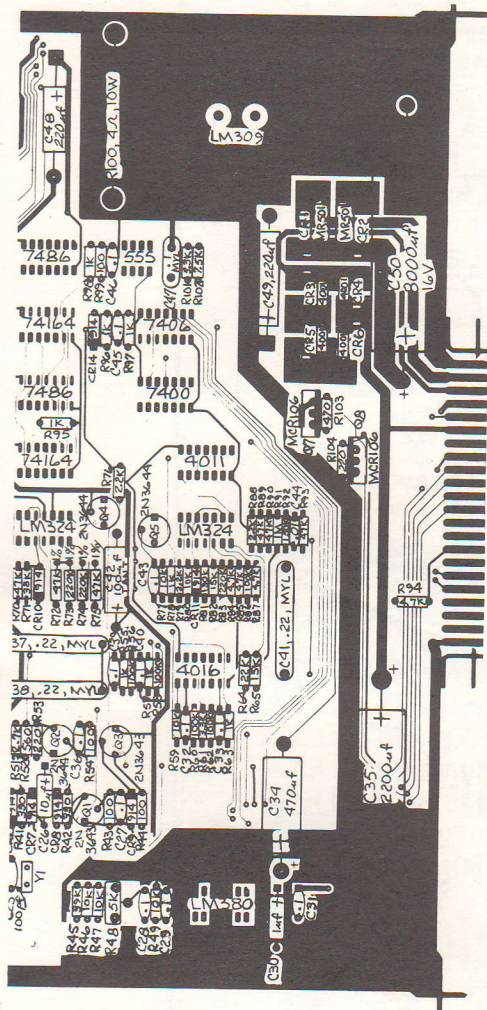

NOTES: UNLESS OTHERWISE SPECIFIED

1. INSTALL MFC6040'S IN POSITIONS FB AND MB. THESE MAY BE SUBSTITUTED BY MFC3340'S AT POSITIONS HB AND LB.
2. USE THIS ASSY DWG WITH P.C. BD. 005845, REV 'B'.

UNLESS OTHERWISE SPECIFIED DIMENSIONS ARE IN INCHES TOLERANCES ON: ANGLES = ±1° SURFACE FINISH ✓	DO NOT SCALE DRAWING	 ATARI INCORPORATED 14600 Winchester Boulevard Los Gatos, California 95030		
	MATERIAL: SEE P/L A005844-01		DRAWN BY _____ DATE _____ CHECKED _____ ENGINEER _____	TITLE ASSEMBLY LE MANS P.C. BOARD
FINISH:	PROJECT ENGINEER _____ MFG ENGINEER _____	SIZE <b>D</b>	DRAWING NO. A005844-01	REV C
SCALE 1/1		SHEET 1 OF 1		

REVISION	DATE	BY	DESCRIPTION
1	10-15-58	W. J. P.	INITIAL DESIGN
2	11-10-58	W. J. P.	REVISIONS TO MECHANICAL
3	12-15-58	W. J. P.	REVISIONS TO ELECTRICAL
4	1-15-59	W. J. P.	REVISIONS TO MECHANICAL
5	2-15-59	W. J. P.	REVISIONS TO ELECTRICAL
6	3-15-59	W. J. P.	REVISIONS TO MECHANICAL
7	4-15-59	W. J. P.	REVISIONS TO ELECTRICAL
8	5-15-59	W. J. P.	REVISIONS TO MECHANICAL
9	6-15-59	W. J. P.	REVISIONS TO ELECTRICAL
10	7-15-59	W. J. P.	REVISIONS TO MECHANICAL
11	8-15-59	W. J. P.	REVISIONS TO ELECTRICAL
12	9-15-59	W. J. P.	REVISIONS TO MECHANICAL
13	10-15-59	W. J. P.	REVISIONS TO ELECTRICAL
14	11-15-59	W. J. P.	REVISIONS TO MECHANICAL
15	12-15-59	W. J. P.	REVISIONS TO ELECTRICAL
16	1-15-60	W. J. P.	REVISIONS TO MECHANICAL
17	2-15-60	W. J. P.	REVISIONS TO ELECTRICAL
18	3-15-60	W. J. P.	REVISIONS TO MECHANICAL
19	4-15-60	W. J. P.	REVISIONS TO ELECTRICAL
20	5-15-60	W. J. P.	REVISIONS TO MECHANICAL
21	6-15-60	W. J. P.	REVISIONS TO ELECTRICAL
22	7-15-60	W. J. P.	REVISIONS TO MECHANICAL
23	8-15-60	W. J. P.	REVISIONS TO ELECTRICAL
24	9-15-60	W. J. P.	REVISIONS TO MECHANICAL
25	10-15-60	W. J. P.	REVISIONS TO ELECTRICAL
26	11-15-60	W. J. P.	REVISIONS TO MECHANICAL
27	12-15-60	W. J. P.	REVISIONS TO ELECTRICAL
28	1-15-61	W. J. P.	REVISIONS TO MECHANICAL
29	2-15-61	W. J. P.	REVISIONS TO ELECTRICAL
30	3-15-61	W. J. P.	REVISIONS TO MECHANICAL
31	4-15-61	W. J. P.	REVISIONS TO ELECTRICAL
32	5-15-61	W. J. P.	REVISIONS TO MECHANICAL
33	6-15-61	W. J. P.	REVISIONS TO ELECTRICAL
34	7-15-61	W. J. P.	REVISIONS TO MECHANICAL
35	8-15-61	W. J. P.	REVISIONS TO ELECTRICAL
36	9-15-61	W. J. P.	REVISIONS TO MECHANICAL
37	10-15-61	W. J. P.	REVISIONS TO ELECTRICAL
38	11-15-61	W. J. P.	REVISIONS TO MECHANICAL
39	12-15-61	W. J. P.	REVISIONS TO ELECTRICAL
40	1-15-62	W. J. P.	REVISIONS TO MECHANICAL
41	2-15-62	W. J. P.	REVISIONS TO ELECTRICAL
42	3-15-62	W. J. P.	REVISIONS TO MECHANICAL
43	4-15-62	W. J. P.	REVISIONS TO ELECTRICAL
44	5-15-62	W. J. P.	REVISIONS TO MECHANICAL
45	6-15-62	W. J. P.	REVISIONS TO ELECTRICAL
46	7-15-62	W. J. P.	REVISIONS TO MECHANICAL
47	8-15-62	W. J. P.	REVISIONS TO ELECTRICAL
48	9-15-62	W. J. P.	REVISIONS TO MECHANICAL
49	10-15-62	W. J. P.	REVISIONS TO ELECTRICAL
50	11-15-62	W. J. P.	REVISIONS TO MECHANICAL
51	12-15-62	W. J. P.	REVISIONS TO ELECTRICAL
52	1-15-63	W. J. P.	REVISIONS TO MECHANICAL
53	2-15-63	W. J. P.	REVISIONS TO ELECTRICAL
54	3-15-63	W. J. P.	REVISIONS TO MECHANICAL
55	4-15-63	W. J. P.	REVISIONS TO ELECTRICAL
56	5-15-63	W. J. P.	REVISIONS TO MECHANICAL
57	6-15-63	W. J. P.	REVISIONS TO ELECTRICAL
58	7-15-63	W. J. P.	REVISIONS TO MECHANICAL
59	8-15-63	W. J. P.	REVISIONS TO ELECTRICAL
60	9-15-63	W. J. P.	REVISIONS TO MECHANICAL
61	10-15-63	W. J. P.	REVISIONS TO ELECTRICAL
62	11-15-63	W. J. P.	REVISIONS TO MECHANICAL
63	12-15-63	W. J. P.	REVISIONS TO ELECTRICAL
64	1-15-64	W. J. P.	REVISIONS TO MECHANICAL
65	2-15-64	W. J. P.	REVISIONS TO ELECTRICAL
66	3-15-64	W. J. P.	REVISIONS TO MECHANICAL
67	4-15-64	W. J. P.	REVISIONS TO ELECTRICAL
68	5-15-64	W. J. P.	REVISIONS TO MECHANICAL
69	6-15-64	W. J. P.	REVISIONS TO ELECTRICAL
70	7-15-64	W. J. P.	REVISIONS TO MECHANICAL
71	8-15-64	W. J. P.	REVISIONS TO ELECTRICAL
72	9-15-64	W. J. P.	REVISIONS TO MECHANICAL
73	10-15-64	W. J. P.	REVISIONS TO ELECTRICAL
74	11-15-64	W. J. P.	REVISIONS TO MECHANICAL
75	12-15-64	W. J. P.	REVISIONS TO ELECTRICAL
76	1-15-65	W. J. P.	REVISIONS TO MECHANICAL
77	2-15-65	W. J. P.	REVISIONS TO ELECTRICAL
78	3-15-65	W. J. P.	REVISIONS TO MECHANICAL
79	4-15-65	W. J. P.	REVISIONS TO ELECTRICAL
80	5-15-65	W. J. P.	REVISIONS TO MECHANICAL
81	6-15-65	W. J. P.	REVISIONS TO ELECTRICAL
82	7-15-65	W. J. P.	REVISIONS TO MECHANICAL
83	8-15-65	W. J. P.	REVISIONS TO ELECTRICAL
84	9-15-65	W. J. P.	REVISIONS TO MECHANICAL
85	10-15-65	W. J. P.	REVISIONS TO ELECTRICAL
86	11-15-65	W. J. P.	REVISIONS TO MECHANICAL
87	12-15-65	W. J. P.	REVISIONS TO ELECTRICAL
88	1-15-66	W. J. P.	REVISIONS TO MECHANICAL
89	2-15-66	W. J. P.	REVISIONS TO ELECTRICAL
90	3-15-66	W. J. P.	REVISIONS TO MECHANICAL
91	4-15-66	W. J. P.	REVISIONS TO ELECTRICAL
92	5-15-66	W. J. P.	REVISIONS TO MECHANICAL
93	6-15-66	W. J. P.	REVISIONS TO ELECTRICAL
94	7-15-66	W. J. P.	REVISIONS TO MECHANICAL
95	8-15-66	W. J. P.	REVISIONS TO ELECTRICAL
96	9-15-66	W. J. P.	REVISIONS TO MECHANICAL
97	10-15-66	W. J. P.	REVISIONS TO ELECTRICAL
98	11-15-66	W. J. P.	REVISIONS TO MECHANICAL
99	12-15-66	W. J. P.	REVISIONS TO ELECTRICAL
100	1-15-67	W. J. P.	REVISIONS TO MECHANICAL
101	2-15-67	W. J. P.	REVISIONS TO ELECTRICAL
102	3-15-67	W. J. P.	REVISIONS TO MECHANICAL
103	4-15-67	W. J. P.	REVISIONS TO ELECTRICAL
104	5-15-67	W. J. P.	REVISIONS TO MECHANICAL
105	6-15-67	W. J. P.	REVISIONS TO ELECTRICAL
106	7-15-67	W. J. P.	REVISIONS TO MECHANICAL
107	8-15-67	W. J. P.	REVISIONS TO ELECTRICAL
108	9-15-67	W. J. P.	REVISIONS TO MECHANICAL
109	10-15-67	W. J. P.	REVISIONS TO ELECTRICAL
110	11-15-67	W. J. P.	REVISIONS TO MECHANICAL
111	12-15-67	W. J. P.	REVISIONS TO ELECTRICAL
112	1-15-68	W. J. P.	REVISIONS TO MECHANICAL
113	2-15-68	W. J. P.	REVISIONS TO ELECTRICAL
114	3-15-68	W. J. P.	REVISIONS TO MECHANICAL
115	4-15-68	W. J. P.	REVISIONS TO ELECTRICAL
116	5-15-68	W. J. P.	REVISIONS TO MECHANICAL
117	6-15-68	W. J. P.	REVISIONS TO ELECTRICAL
118	7-15-68	W. J. P.	REVISIONS TO MECHANICAL
119	8-15-68	W. J. P.	REVISIONS TO ELECTRICAL
120	9-15-68	W. J. P.	REVISIONS TO MECHANICAL
121	10-15-68	W. J. P.	REVISIONS TO ELECTRICAL
122	11-15-68	W. J. P.	REVISIONS TO MECHANICAL
123	12-15-68	W. J. P.	REVISIONS TO ELECTRICAL
124	1-15-69	W. J. P.	REVISIONS TO MECHANICAL
125	2-15-69	W. J. P.	REVISIONS TO ELECTRICAL
126	3-15-69	W. J. P.	REVISIONS TO MECHANICAL
127	4-15-69	W. J. P.	REVISIONS TO ELECTRICAL
128	5-15-69	W. J. P.	REVISIONS TO MECHANICAL
129	6-15-69	W. J. P.	REVISIONS TO ELECTRICAL
130	7-15-69	W. J. P.	REVISIONS TO MECHANICAL
131	8-15-69	W. J. P.	REVISIONS TO ELECTRICAL
132	9-15-69	W. J. P.	REVISIONS TO MECHANICAL
133	10-15-69	W. J. P.	REVISIONS TO ELECTRICAL
134	11-15-69	W. J. P.	REVISIONS TO MECHANICAL
135	12-15-69	W. J. P.	REVISIONS TO ELECTRICAL
136	1-15-70	W. J. P.	REVISIONS TO MECHANICAL
137	2-15-70	W. J. P.	REVISIONS TO ELECTRICAL
138	3-15-70	W. J. P.	REVISIONS TO MECHANICAL
139	4-15-70	W. J. P.	REVISIONS TO ELECTRICAL
140	5-15-70	W. J. P.	REVISIONS TO MECHANICAL
141	6-15-70	W. J. P.	REVISIONS TO ELECTRICAL
142	7-15-70	W. J. P.	REVISIONS TO MECHANICAL
143	8-15-70	W. J. P.	REVISIONS TO ELECTRICAL
144	9-15-70	W. J. P.	REVISIONS TO MECHANICAL
145	10-15-70	W. J. P.	REVISIONS TO ELECTRICAL
146	11-15-70	W. J. P.	REVISIONS TO MECHANICAL
147	12-15-70	W. J. P.	REVISIONS TO ELECTRICAL
148	1-15-71	W. J. P.	REVISIONS TO MECHANICAL
149	2-15-71	W. J. P.	REVISIONS TO ELECTRICAL
150	3-15-71	W. J. P.	REVISIONS TO MECHANICAL
151	4-15-71	W. J. P.	REVISIONS TO ELECTRICAL
152	5-15-71	W. J. P.	REVISIONS TO MECHANICAL
153	6-15-71	W. J. P.	REVISIONS TO ELECTRICAL
154	7-15-71	W. J. P.	REVISIONS TO MECHANICAL
155	8-15-71	W. J. P.	REVISIONS TO ELECTRICAL
156	9-15-71	W. J. P.	REVISIONS TO MECHANICAL
157	10-15-71	W. J. P.	REVISIONS TO ELECTRICAL
158	11-15-71	W. J. P.	REVISIONS TO MECHANICAL
159	12-15-71	W. J. P.	REVISIONS TO ELECTRICAL
160	1-15-72	W. J. P.	REVISIONS TO MECHANICAL
161	2-15-72	W. J. P.	REVISIONS TO ELECTRICAL
162	3-15-72	W. J. P.	REVISIONS TO MECHANICAL
163	4-15-72	W. J. P.	REVISIONS TO ELECTRICAL
164	5-15-72	W. J. P.	REVISIONS TO MECHANICAL
165	6-15-72	W. J. P.	REVISIONS TO ELECTRICAL
166	7-15-72	W. J. P.	REVISIONS TO MECHANICAL
167	8-15-72	W. J. P.	REVISIONS TO ELECTRICAL
168	9-15-72	W. J. P.	REVISIONS TO MECHANICAL
169	10-15-72	W. J. P.	REVISIONS TO ELECTRICAL
170	11-15-72	W. J. P.	REVISIONS TO MECHANICAL
171	12-15-72	W. J. P.	REVISIONS TO ELECTRICAL
172	1-15-73	W. J. P.	REVISIONS TO MECHANICAL
173	2-15-73	W. J. P.	REVISIONS TO ELECTRICAL
174	3-15-73	W. J. P.	REVISIONS TO MECHANICAL
175	4-15-73	W. J. P.	REVISIONS TO ELECTRICAL
176	5-15-73	W. J. P.	REVISIONS TO MECHANICAL
177	6-15-73	W. J. P.	REVISIONS TO ELECTRICAL
178	7-15-73	W. J. P.	REVISIONS TO MECHANICAL
179	8-15-73	W. J. P.	REVISIONS TO ELECTRICAL
180	9-15-73	W. J. P.	REVISIONS TO MECHANICAL
181	10-15-73	W. J. P.	REVISIONS TO ELECTRICAL
182	11-15-73	W. J. P.	REVISIONS TO MECHANICAL
183	12-15-73	W. J. P.	REVISIONS TO ELECTRICAL
184	1-15-74	W. J. P.	REVISIONS TO MECHANICAL
185	2-15-74	W. J. P.	REVISIONS TO ELECTRICAL
186	3-15-74	W. J. P.	REVISIONS TO MECHANICAL
187	4-15-74	W. J. P.	REVISIONS TO ELECTRICAL
188	5-15-74	W. J. P.	REVISIONS TO MECHANICAL
189	6-15-74	W. J. P.	REVISIONS TO ELECTRICAL
190	7-15-74	W. J. P.	REVISIONS TO MECHANICAL
191	8-15-74	W. J. P.	REVISIONS TO ELECTRICAL
192	9-15-74	W. J. P.	REVISIONS TO MECHANICAL
193	10-15-74	W. J. P.	REVISIONS TO ELECTRICAL
194	11-15-74	W. J. P.	REVISIONS TO MECHANICAL
195	12-15-74	W. J. P.	REVISIONS TO ELECTRICAL
196	1-15-75	W. J. P.	REVISIONS TO MECHANICAL
197	2-15-75	W. J. P.	REVISIONS TO ELECTRICAL
198	3-15-75	W. J. P.	REVISIONS TO MECHANICAL
199	4-15-75	W. J. P.	REVISIONS TO ELECTRICAL
200	5-15-75	W. J. P.	REVISIONS TO MECHANICAL

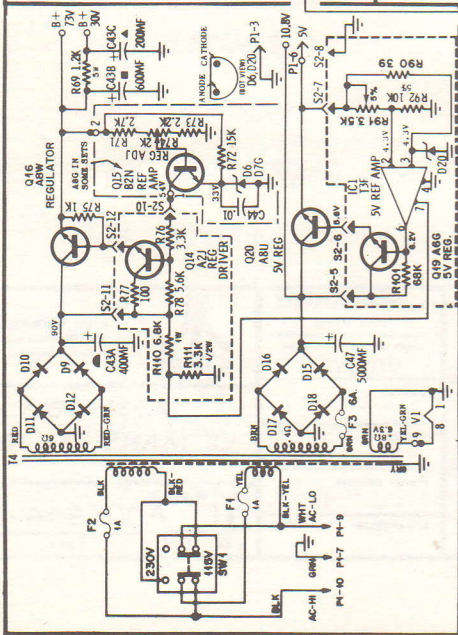
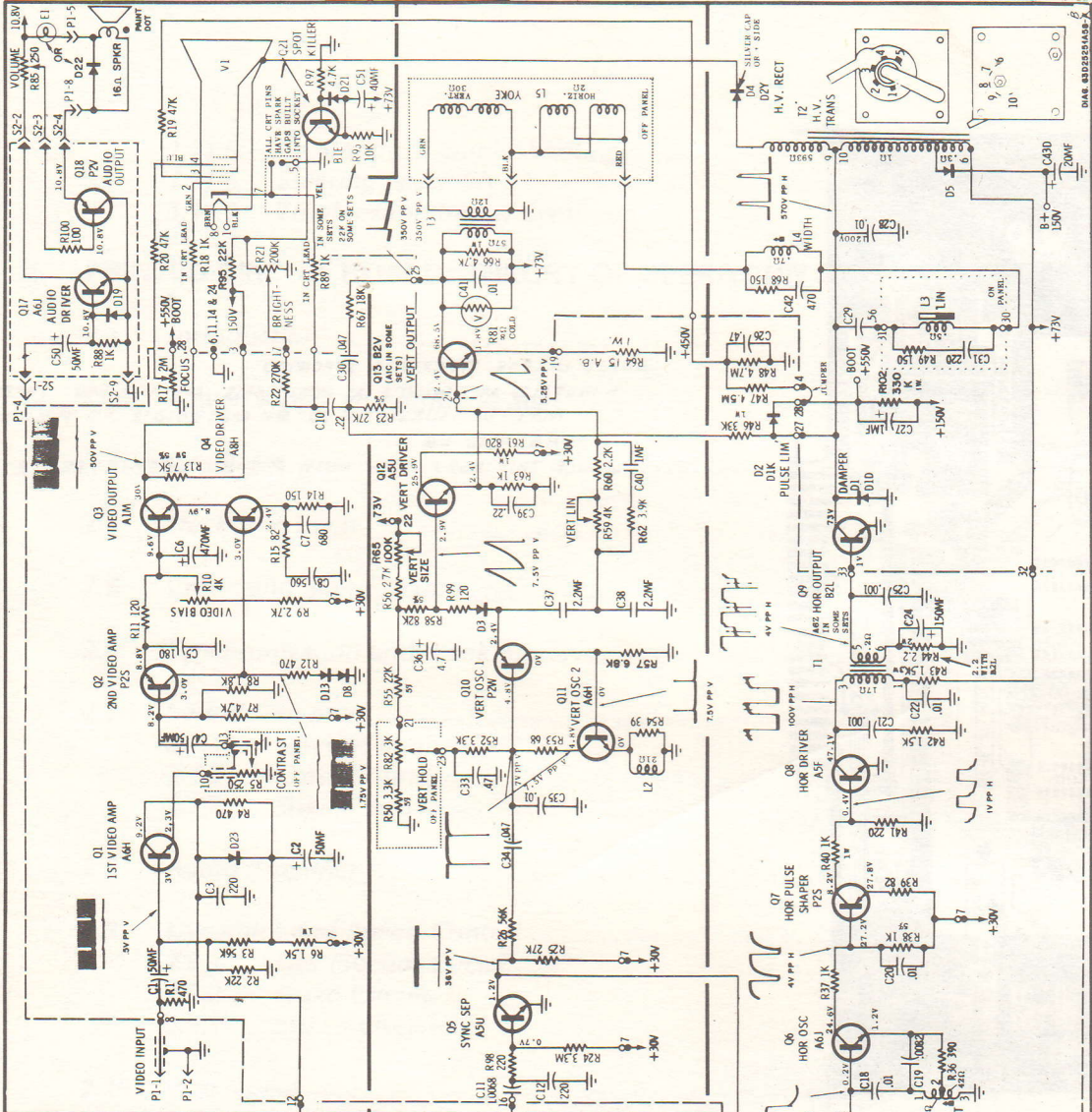

**NOTES:**

- VOLTAGES VARY WITH ASSOCIATED CONTROL SETTING.
- ALL VOLTAGES + 10% AS MEASURED FROM POINT INDICATED TO CHASSIS USING A HIGH IMPEDANCE VTVM, NO SIGNAL INPUT.
- CONTRAST & BRIGHTNESS CONTROLS AT MAXIMUM, ALL OTHER CONTROLS IN NORMAL OPERATING POSITION.

**WAVEFORM MEASUREMENTS**

- TAKEN FROM POINT INDICATED TO CHASSIS WITH A WIDE-BAND OSCILLOSCOPE SYNCED NEAR SWEEP RATE INDICATED. INPUT SIGNAL 5V PP, CONTRAST & BRIGHTNESS CONTROLS AT MAXIMUM, ALL OTHER CONTROLS IN NORMAL OPERATING POSITION.
- INDICATES PRINTER CIRCUIT CARDS.

UNLESS OTHERWISE SPECIFIED: ALL OTHERS PP, CAPACITANCE VALUES IN MICROFARADS. FOR COMPLETE WAVEFORM MEASUREMENTS REFER TO PARTS LIST.

RESISTORS ARE 10% 1/2W.

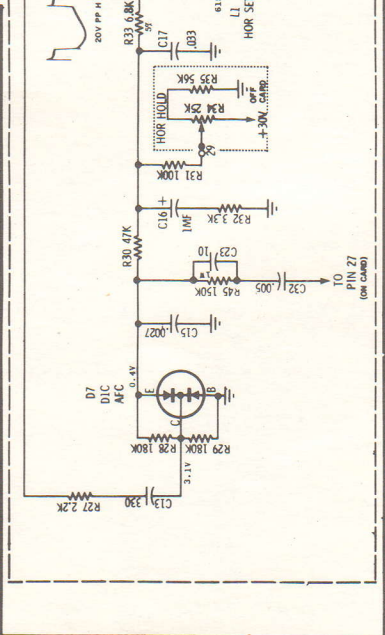

DIAG. 63D2525A58-6

LEANS

OPERATION AND SERVICE MANUAL

1964  
1965  
1966

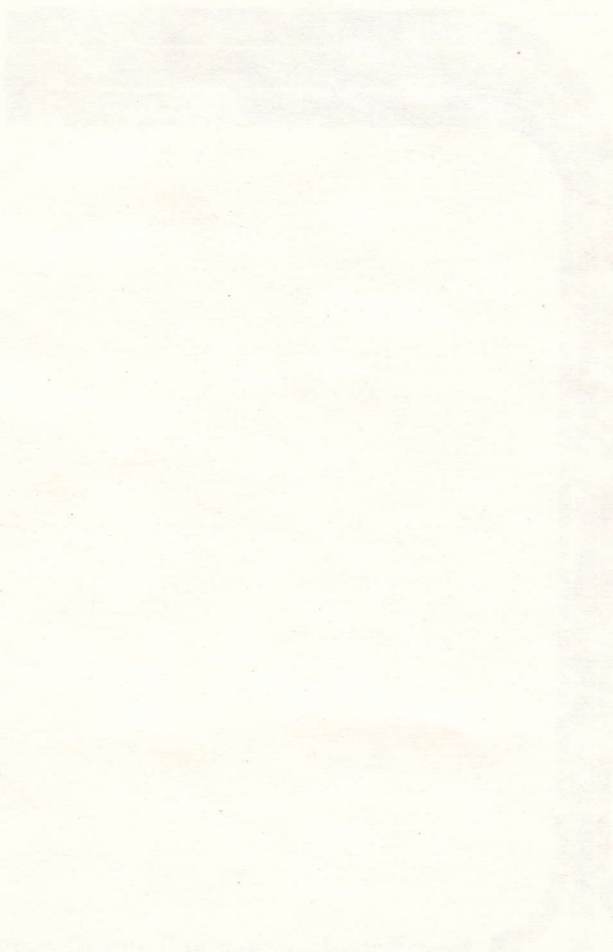

ATARE

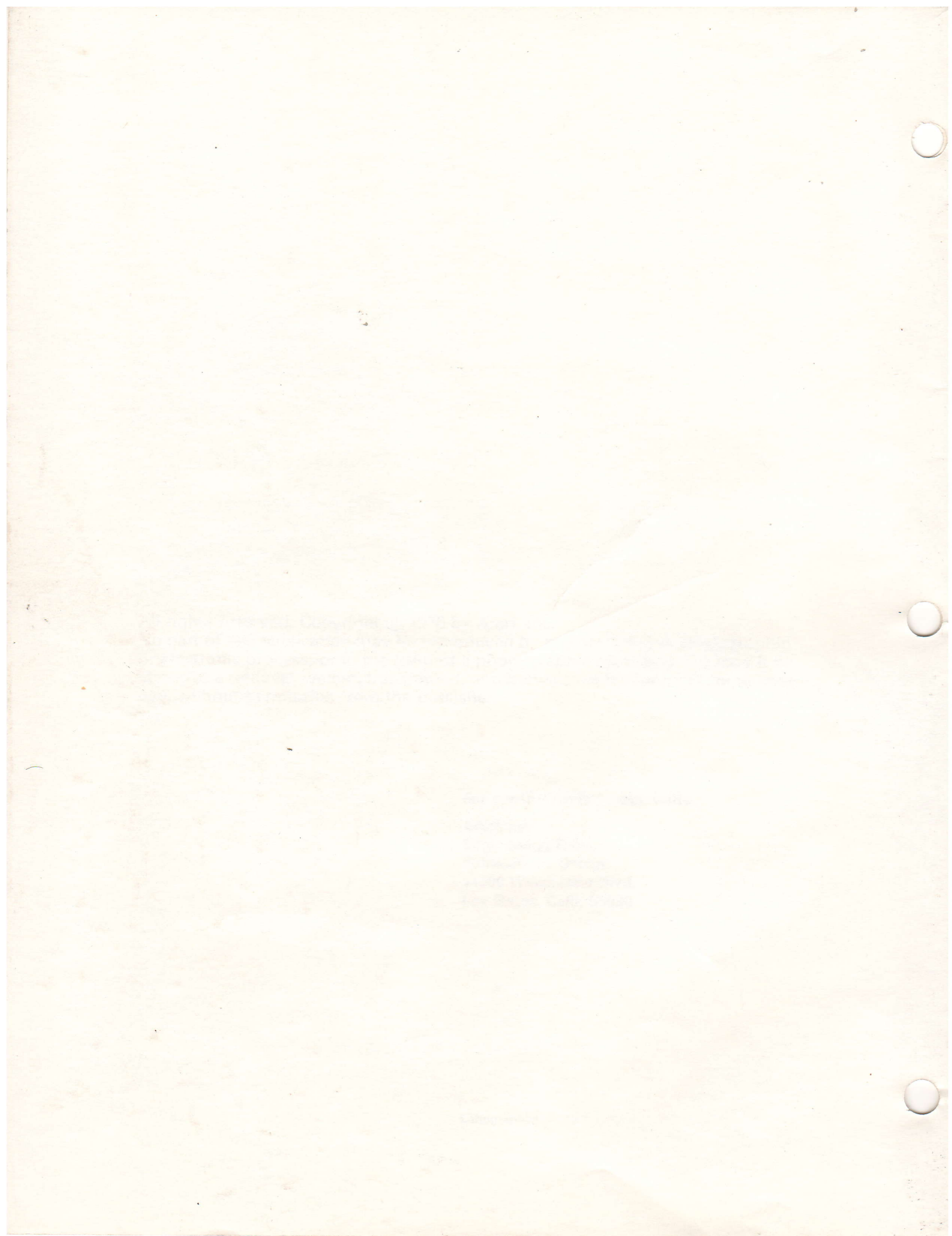

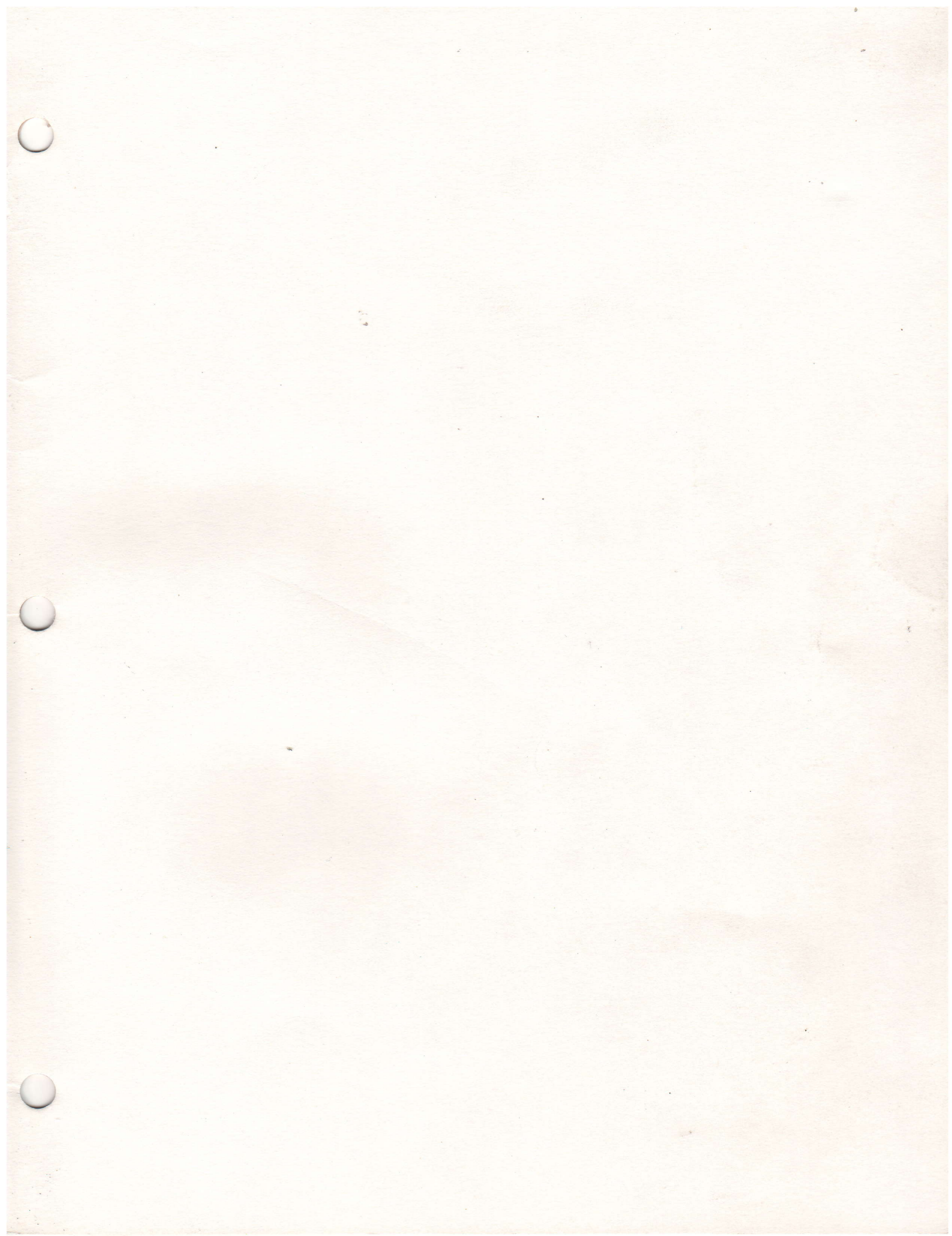

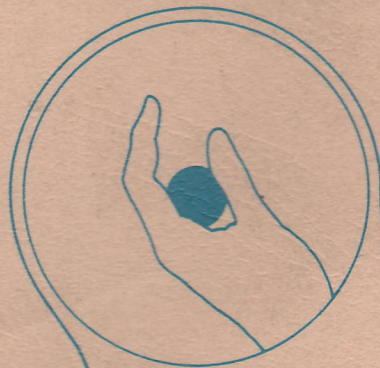
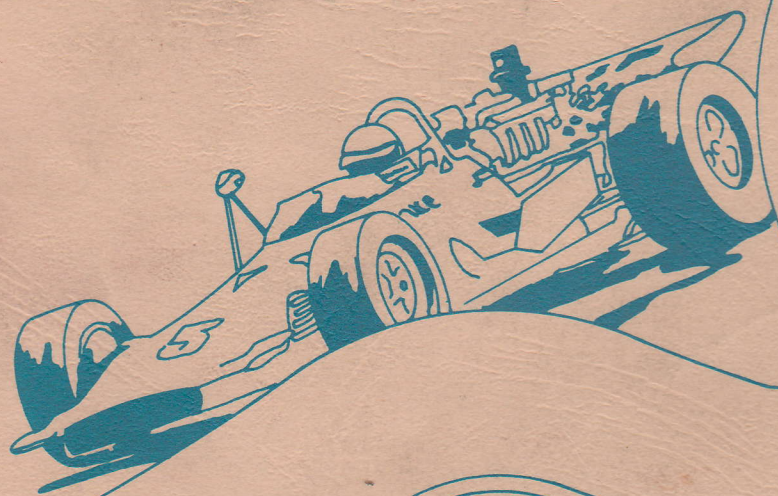

ATARI INC.  
14600 WINCHESTER BLVD  
LOS GATOS, CA 95030  
408/374-2440 • TELEX 357-488