

SEGA®

October, 2002

STRATEGY

News You Can Use in the Arcade Market

SEGA
creates
a coin-op
BIG BANG!

SEGA®

AMOA & IAAPA Special Edition



Dear Sega Customers,

These are exciting times for Sega and the entire coin-op industry. At this year's AMOA show, we're introducing an entirely new division and product line, Sega's **Special Products Division**. This new division will focus on non-video coin-op design – primarily ticket redemption and self-contained merchandising products. Two industry veterans, Drew Maniscalco (pictured, left) and Ron Malinowski have been the force behind this new endeavor. They've worked tirelessly creating a business plan, designing and developing product, and procuring licensed titles. What started as a white paper proposal one year ago has matured into a division with a line-up that takes us into 2004 and beyond. In fact, between now and the end of our fiscal year (March 31, 2003), this division will release four new products, Sonic & Tail's Spinner, Crazy Taxi Roll-down, a children's novelty capsule dispensing game, and a self-contained merchandiser based on a licensed, internationally broadcast television program. The addition of the **Special Products Division** enables Sega to better meet the needs of you, our customers. By expanding the breadth of our product offerings, we're enabling a wider base of end users to benefit from the quality product Sega has always been known for.

Our core video business has never been stronger. New hardware systems, including the Chihiro platform – co-developed by Sega and Microsoft – and the Tri-Force platform – co-developed by Sega, Namco, and Nintendo – bring unprecedented game play experiences to coin-op. These systems allow our game designers to develop their visions in ways only dreamed of a short time ago. Players will see the fruits of our labors in greater content, better graphics, and the inclusion of complementary technologies designed to expand their enjoyment and immersion in coin-op game play.

Sega's commitment to the coin-op industry remains unwavering. The quality and innovation of the products you see at this year's show dramatically demonstrate this fact. The entire Sega family has a simple slogan to remind our customers, our competitors, and ourselves of this commitment...

"Get used to it!"

Alan D. Stone
President, COO
Sega Enterprises, Inc. (USA)

Sega Enterprises, Inc. (USA) • 650 Townsend St., Suite 575 • San Francisco, CA 94103
phone 415-701-6500 • fax 415-701-6568 • www.segagarcade.com



Drew Maniscalco

Ron Malinowski

"Players will see the fruits of our labors in greater content, better graphics, and the inclusion of complementary technologies designed to expand their enjoyment and immersion in coin-op game play."

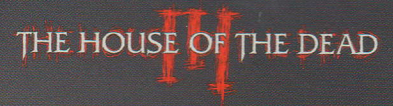
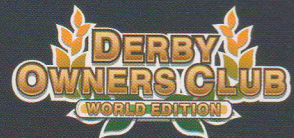



Crazy Taxi High Roller

"Are you ready for some crazy money!?"

One of the most successful Arcade Driving Games ever released is back and it's crazier than ever. Hitmaker, the R&D Team behind the original Crazy Taxi, has taken the simple game rules of pick-up and drop-off to a new level.

Crazy Taxi High Roller allows players to break the rules of the road in three Major US cities:

West Coast (San Francisco) – Based on the original Crazy Taxi. Cabbies in this stage can now execute the "Crazy Hop".

Small Apple (New York) – An intricate slice of the "Big Apple" at nighttime. The "Small Apple" has new backgrounds and course changes, which are exclusive to the arcade version!

Glitter Oasis (Las Vegas) – An all "New" course featuring an amazing blend of Big City glamour (the Vegas Strip), and the breathtaking Majesty of Nature (the Grand and Redrock Canyons).



Game Objective

Each city offers a myriad of destinations and traffic patterns guaranteed to challenge even the craziest cabbies. There are 12 cabbies (8 "new" cabbies making their first arcade appearances), each with their own, unique cabs built to make money. Not to mention a very diverse group of passengers hoping to be delivered to their destination on time and in one piece. In Crazy Taxi High Roller, cabbies can pick-up more than one passenger (up to 4), at a time, each with a different destination!

*Yes, Folks it is time to
"Make Some Crazy Money!"*

Game Features

- 3 Big City Courses
- 12 Professional Cab Drivers
- Multiple Passenger Pick-up & Drop off
- Unique "Arcade Only" Gameplay
- Licensed BGM by Popular Rock Bands

Availability – TBD

Configuration – 1 Player 29" Sit-down



Original game © SEGA © Hitmaker/SEGA 2002

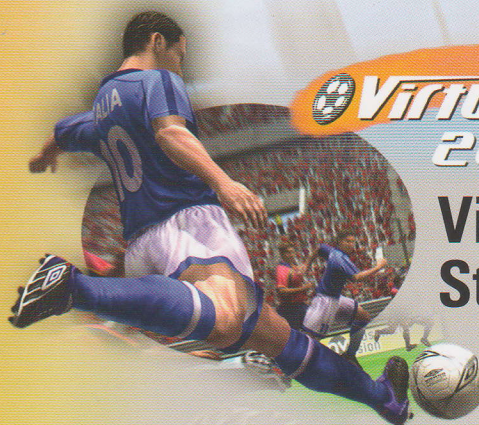

Virtua Striker 2002

Virtua Striker 2002

FACT: Soccer (fútbol) is the world's most popular spectator sport.

FACT: The Virtua Striker Series is Sega's All-Time, Best Selling Sports Video Game Title

Coincidence? We Think Not!

AmusementVision LTD has developed the first Sega sports arcade title, Virtua Striker 2002, to be powered by the all-new TriForce Arcade Game Board.

While maintaining the game simple controls (1 joystick and 3 push buttons), AmusementVision has taken advantage of TriForce's unbelievable processing power, allowing for precise and responsive player movements. TriForce's tremendous graphic capabilities create player and stadium models that are highly detailed and incredibly realistic. TriForce's expansive CPU Intelligence increases team selections and player formations while adding a multitude of exciting replay videos and camera angles. TriForce Technology delivers a more competitive and balanced game play experience over previous Virtua Striker Versions.

Game Objective

Players choosing to play by themselves compete against the CPU in 16-team world tournament. All it takes is four wins to become the World Champion! One catch, the CPU teams get tougher as you progress to the finals!

Two Player Match Play pits players against each other in a 3-minute battle for Virtua Striker Supremacy. CPU Officials will assess penalties (yellow card & red cards), against players who play a little too hard. New and multiple offensive and defensive formations help make for some very exciting matches.

*The World Championship
Soccer Tournament isn't over!
It is just getting started!*

Game Features

- 63 Teams
- 13 Stadiums
- Multiple Offensive and Defensive Formations
- "Close Shot" and "Goal" Replays
- TriForce Arcade Board w/GD-Rom

Availability – October 2002

Configuration – Full 2 Player Video Conversion Kit



TRIFORCE is a Trademark of NINTENDO.



Original Game © SEGA © Amusement Vision/SEGA 2001, 2002

Future gaming technology

Japanese Arcades Go Cellular!!

Japanese Arcades are using cellular technology to drive players back into the arcades. Sega and NTT DoCoMo (the leading Japanese telecommunications company) have been interactively networking local arcades with players who use cellular phones with I-mode technology*.

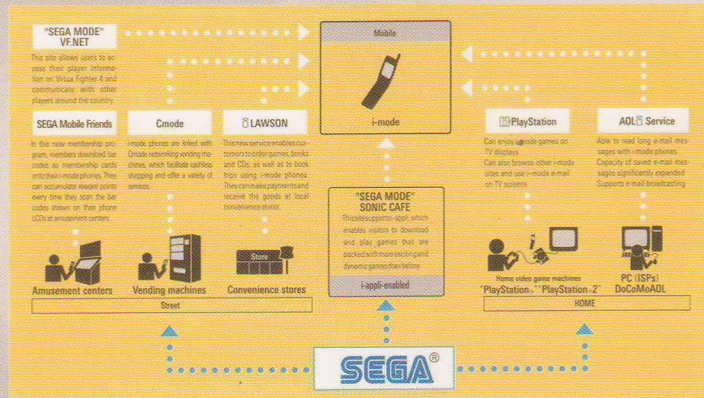

* Note: I-mode not currently available in the United States.

Sega's Virtua Fighter 4 is the first arcade game to be developed with I-mode technology. Players that use a Virtua Fighters access card (similar to the Club Kart and Derby Owners Club cards) can have their playing data transmitted, in real time, to the VF.Net site (an I-mode site). Players can then access this site through the Sega Mode found in their cell phone options menu. Players can check their character's information, nationwide rankings, and communicate with other Virtua Fighter 4 players nationwide.

Sega has also developed a membership program that rewards players for visiting participating arcades. The membership program is controlled by showing a barcode on the cell phone screen at an I-mode scanner placed at the arcade to keep track of the players. Players are awarded each time they visit the arcade. These reward points can be exchanged for a variety of gifts. Participating Arcades also offer discount coupons, which are delivered to the players via e-mail. Sega plans to have 350 Amusement Centers participating in this program by years end.

And you thought cell phones were just for making calls!



Strange but true video games! "Walk the Dog!"

Sega's "Walk the Dog" is definitely one for the ages. Players actually get a workout by taking their favorite canine for a simulated walk on a regulation, gymnasium quality treadmill. Utilizing a force-feedback leash control, players can chose from six popular pooches and three different routes:

Pet Shop – In this beginner level players can take their dog for a casual walk to the pet shop.

Frisbee in the Park – This intermediate level quickens the pace with a trip to the park for some fun with a Frisbee.

Get Home Before Dark – The expert level requires a lot of stamina as players need to get home quickly and safely before it gets too dark.

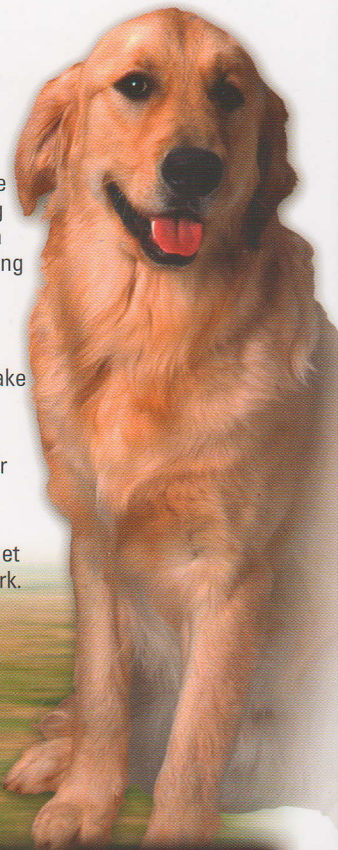

Game Objective

Players must complete the exercises in each course before the time limit expires. Just to keep the game interesting, players will randomly be challenged with some natural occurrences when walking their dog. How about a chance encounter with a cat, or having to avoid being hit by an automobile, these things happen in real life! Truly not a game for the faint of heart!

If you don't believe us, check out this cabinet shot.

Game Features

- 50" Monitor
- Authentic, regulation gymnasium treadmill
- 3 Different routes:
 - Pet Shop – Park – Home
- 6 Different Canines
 - Poodle
 - Siberian Husky
 - Pug
 - Welsh Corgi
 - Labrador Retriever
 - Shiba

Availability – TBA
Configuration – 50" 1 Player



Double D's Corner

Parts & Technical Support

WWW.SEUSERVICE.COM

Darl Davidson and Dave Cantrelle are the backbone upon which Sega's parts and technical support departments have built their well-earned reputations of consistently performing above and beyond the expectations of our customers. This level of excellence doesn't just happen. It comes from constantly seeking out, and investing in better technologies, tools, and procedures. These investments have generated dramatic improvements in the speed and efficiency of the service they provide.

To demonstrate, look no further than their award-winning interactive web site, **www.seuservice.com**. Praised by its many users, this site provides an enormous amount of data arranged in an intuitive, user-friendly format. The **www.seuservice.com** web site contains PDF files containing over 70 game manuals, 90 service bulletins and 50 exploded view assembly drawings with actual 3D photographs of the assemblies. Rolling your cursor over a specific part on either the assembly drawing or 3-D picture results in that parts picture appearing on a pop-up screen. It's a troubleshooting aid that simply can't be beat.

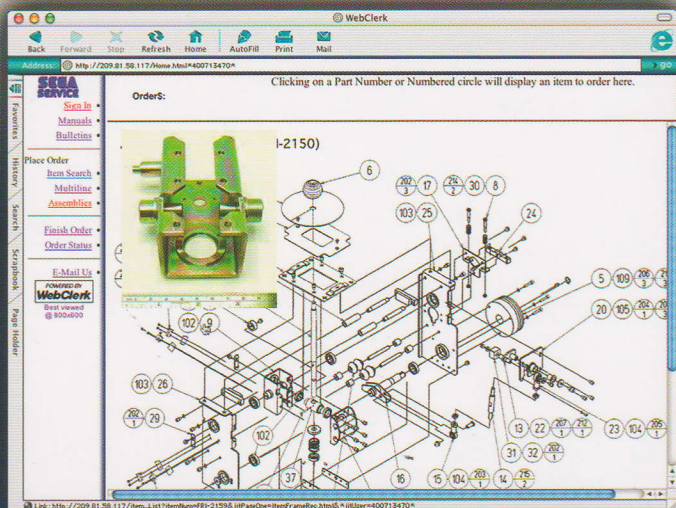

www.seuservice.com

The **www.seuservice.com** web site contains PDF files containing over 70 game manuals, 90 service bulletins and 50 exploded view assembly drawings with actual 3D photographs of the assemblies.

SEGA®



Darl Davidson



Dave Cantrelle

Sega Improves on Gun Game Technology

Sega's Exclusive Infrared Gun system is a giant leap forward in gun-game technology. It's many improvements over older, raster-scan guns include:

- **Improved accuracy.** Sega's Infrared Gun System does not depend on illuminated group of pixels to pass by the gun lens after the pull of the trigger (this is the screen flash you see in older games). Sega's system continuously cycles the Infrared LEDs and the CCD* Camera in the Gun Assembly. This results in a steady stream feedback to the board system.
- **No Screen Flash** to distract players or raise potential liability concerns for players with undiagnosed epilepsy.
- **Works better in games utilizing projection screen monitors** (deluxe games). The LED array is not affected by size of the screen. Raster Scan games are affected by the angle of the mirror inside a projection screen monitor. Typically, you are not able to shoot all the way to the bottom of the screen in games equipped with older technology guns. This is not a problem for the Infrared System.
- **It is not affected by the quality of the video on the screen.** Raster scan games do not work properly when the CRTs become dirty, the mirrors become dirty, or the monitor is poorly adjusted. The Infrared system does not use the video image on the screen for targeting.

The combination of the above listed benefits results in players enjoying a more seamless game-play experience and a more reliable system for the location owner and operator.

*A charge-coupled device (CCD) is a light-sensitive integrated circuit that stores and displays the data for an image in such a way that each pixel (picture element) in the image is converted into an electrical charge the intensity of which is related to a color in the color spectrum. For a system supporting 65,535 colors, there will be a separate value for each color that can be stored and recovered.

DERBY OWNERS CLUB

WORLD EDITION



Would you buy a video game that:

- Increases the earnings of the entire location rather than just moving the pile of money from one cabinet to another?
- Increases your food and beverage sales by double-digit percentage levels?
- Increases the number of per-week visits by your guests?
- Increases the amount your guests spend per-visit?
- Increases your guest's per-visit length of stay?



Introducing

Derby Owners Club – World Edition

"I would say our sports bar business is up well over 20 percent since DOC arrived. We've had to add wait staff just to service the players on DOC."

Anonymous bartender at Doc location.

How many video games do you own that encourage players to take a piece home with them every time they play?

That's exactly what Derby Owners Club – World Edition does. Utilizing Sega's exclusive MCRD* technology, players take their horse with them on a convenient, credit card-sized storage device. They can use their Derby Owners Club Card to race their horse in any Derby Owners Club – World Edition game in the country.

*Memory Card Reader and Dispenser (see inside back)

MCRD allows players to:

- Breed and name their thoroughbred racehorse.
- Pick racing silk's pattern and color.
- Save race results.

MCRD builds player loyalty and dramatically increases monthly visits.

Derby Owners Club – World Edition is an RPG (Roll Playing Game), in which players are thoroughbred racehorse breeders, trainers, jockeys and owners.



"This is the most addictive video game I've ever played."

Anonymous DOC player at Jillian's Baltimore

“The game is so successful here in Chicago that we usually have a 1-2 hour waiting list during the week to play after 5:00 p.m.”

Tommy Sanders, regular DOC Player and owner of Rambo Stables, a stable he created playing DOC at Dave & Busters, Chicago, IL

DOC Earnings

DOC earnings have set records in every location where it's been installed. Our three test games are averaging over \$850 per day and \$6,100 per week.

- Location # 1 per week average for 12 weeks = \$4,950.
Average weekly ranking #1
- Location # 2 per week average for 8 weeks = \$6,900.
Average weekly ranking #1
- Location # 3 per week average for 4 weeks = \$8,000.
Average weekly ranking #1

Very few games have ever been developed that create the kind of long term earnings, player loyalty, and ancillary location benefits Derby Owners Club-World Edition delivers. It's a phenomenon that's poised to sweep across the county. Get caught up in it before it passes you by.

Derby Owners Club – World Edition

Catch the Fever!

Game Dimensions

183" W x 234" D x 95"H (as shown)
Weight 3,680 lbs (approx.)

Power requirements

- 8 satellites
- each requiring 110Volts @ 3 Amp per
- 1 Main display unit
- requiring 110 volts @ 8 Amps

East Coast
Location Based Entertainment Center

	wks rpld	Per wk avg	Week 6 5/19/02	Week 7 5/27/02
1	DOC 6 Plyr	\$ 6,096.13	\$ 6,196.69	\$ 6,603.91
2	Nothing But Net 2 Plyr	\$ 4,829.53	\$ 5,414.75	\$ 3,443.75
3	Hyper Bowl 6 Lanes	\$ 5,821.43	\$ 5,071.50	\$ 2,959.50
4	Quinn's Exotic 4 Plyr	\$ 3,011.54	\$ 2,528.77	\$ 2,700.00

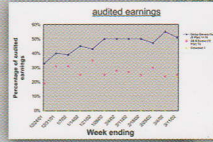

Midwest Location Based Entertainment Center

	# Wks rpld	Per Wks average	9/11/02
1	Derby Owners Club, (6 Plyr)	11.78	\$ 4,449.28
2	D & B Downs (12 Plyr)	12	\$ 3,329.32
3	Colorama	1	\$ 2,803.76
4	Nothing But Net, (2 plyr)	12	\$ 2,864.29
5	Virtual World	1	\$ 2,583.06
Total	52	\$ 11,061.03	\$ 3,689.88



“It's not uncommon to see a player sit down at DOC at 1:00 p.m. and stay on the game until after 12:00 midnight. They eat, drink and party all day at DOC.”

Technical Services manager, Jillian's Baltimore, MD

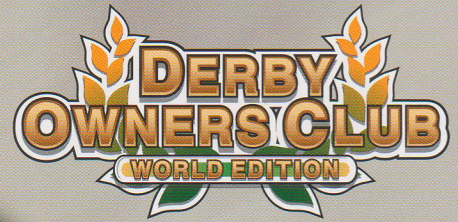

NTRA, the NTRA and Breeders' Cup logos are registered trademarks of the national Thoroughbred Association and are used under license.

Original game © SEGA © Hitmaker/SEGA, 2001



evo•lú-shen (n): the process of change by degrees

Virtua Fighter 4 Evolution

The legendary arcade game, Virtua Fighter has evolved into one of the most successful and highest earning video games available today, Virtua Fighter 4 EVO.

The renowned R&D Team AM2, has done it again, taking the Arcade Martial Art Fighting genre to new earnings heights. Virtua Fighter 4 EVO features the highest technology available today in an economic video conversion kit.

Two new fighters, Brad Burns and Goh Hinogami, take on the original cast of Virtua Fighter 4, with two new styles of fighting Judo and Kick Boxing. To counter these new fighting styles, each original character has been given new fight moves and combos! A new fighting arena has been added, while all the other fighting arenas have been reconfigured for a whole new playing experience. New camera angles and instant replays have been added for special effects. All in all VF4 Evolution is a new and special edition of this time tested Arcade Classic.



Game Features

- 14 Selectable Characters (2 New)
- 1 Boss Character
- 14 Incredibly Detailed Fighting Arenas (1 New)
- 1 Player or 2 Player
- 31 kHz or 15 kHz monitor compatibility

Availability – Mid-September

Configuration – Full Jamma Kit



House of the Dead 3

“Zombies here! Zombies there! Zombies everywhere!”

WOW Entertainment is back with its latest edition of the Arcade Horror Classic “House of the Dead.” “House of the Dead 3” has 3 times the excitement, 3 times the zombies, 3 times the horror, and 3 times the fear! HOTD3 is Sega’s first Arcade Shooting game to be developed on the new Chihiro arcade board co-developed by Sega and MicroSoft. “Chihiro” allowed WOW to develop a game with greater special effects and to increase the number of attacking zombies appearing on the screen versus previous “House of the Dead” games.

Game Objective

In HOTD3, players will select an Agent to start the mission. Using a shotgun instead of a pistol, players will attempt to thwart relentless waves of the undead. Truckloads of zombies can be taken out with one well-aimed blast. Unlike other HOTD editions, players can choose the stages they wish to challenge. Different zombies and Boss characters appear in each stage. Boss characters may appear at the beginning, middle or end of a stage, creating fear even amongst the bravest players. As you progress deep into the game, you’re asked to change your Agent. Changing Agents adds different strategies to the game, increasing the depth of an already challenging game. Events during each stage constantly change! No one game is ever the same! Upon finishing the game – depending on the players’ accomplishments – one of over four endings will be displayed.

WARNING: “Play at your own Risk!”

Game Features

- 29” 31khz Monitor
- 2 player Cooperative play
- 2 Arcade Style Shot Guns
- Multiple Stages & Events
- New Zombies, Weapons and Bosses
- Chihiro Technology

Availability – November

Configuration – TBA



CRAZY TAXI™ ROLL-DOWN



Crazy Taxi Roll-Down

*"Time to make some Crazy Tickets! Are You Ready?"
"Here we go!"*

Sega's New Product Division is looking to capitalize on the success of the Crazy Taxi phenomenon with their new coin roll-down of the same name, Crazy Taxi!

Game Objective

In keeping with the Crazy Taxi theme, one or two players will attempt to roll their coins down the street in an effort to reach the "Pick-up Zone", where passengers are waiting. To reach these passengers, the players' coin must avoid the side-to-side motion of the fully replicated Crazy Taxi Vehicle. Coins hitting the Crazy Taxi will prevent the player from picking up the intended passenger. Should the coin make it past the Crazy Taxi and pass through the Opto-Detector, the player will receive the flashing award value of the passenger picked-up.

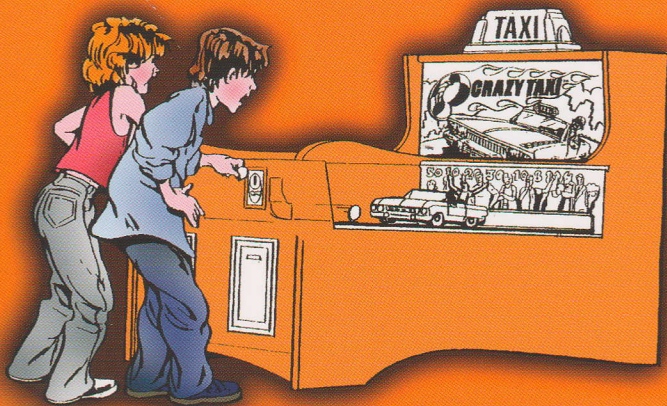

Game features

- 1 or 2 player Action
- Moving 3-D Authentic Crazy Taxi Vehicle
- Sound and Speech effects direct from the Video Game
- Variable percentage settings
- Quality Ticket dispenser

Availability – To Be Determined

Configuration – 2 Player Redemption Roll-down



Sonic & Tail's Spinner

Sega's New Products Division is proud to present its inaugural product, Sonic & Tail's Spinner! What better mascot to launch a new redemption line with than Sonic the Hedgehog! With a character recognition that rivals that of the World Famous Mickey Mouse, Sonic and his companions are sure to attract players of all ages.

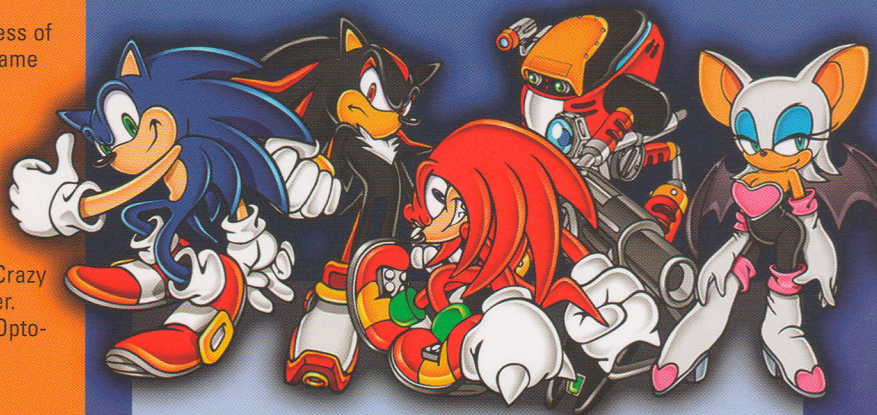

Game Objective

Inserting the proper amount of tokens will activate the Sonic and Tails characters to start spinning around numbers on the playfield. Once the player presses the "Sonic" Button, Sonic will gradually stop on a ticket value. This is the minimum number of tickets that the player will receive. The player will then press the "Tails" Button and Tails will also gradually stop on a bonus "multiplier" value, up to 10 times the Sonic ticket award. Once the game is complete, the number of Sonic tickets multiplied by the Tails bonus value is the award the player receives. Pretty simple and pretty addicting!

Game Features

- Variable Tickets values
- Variable Percentage Settings
- Quality Ticket Dispenser
- Licensed Character Sound and Voice effects

Availability – October

Configuration – 1 player Redemption
Vertical Spinner



Initial D Arcade

Showing creativity and diversity, Sega Rosso has developed a driving game, which is based on the #1 Teen Oriented Cartoon in Japan – Initial D!

The Initial D cartoon centers on a teenage delivery boy, who through his daily deliveries, develops into one of the top street racers in town. He meets challenges everyday, some tougher than others, constantly fine-tuning his vehicle.

True to the cartoon, Initial D Arcade players will have to work hard to be the best. Initial D offers three exciting race modes:

Legend of the Speed – Players race against a Cartoon Rival who is the Fastest Driver on that course.

Time Attack – Players compete against the clock to complete each course within the allotted time – there is no Cartoon Rival in this mode.

Linked Battle – Head to Head competition between two players.

Game Objective

Players compete against the original Cartoon Character Rivals that are the most proficient drivers on each of the 4 Mountain Courses. Players must beat the Cartoon Rival to become the fastest driver for that course. Not an easy feat!

The Memory Card Reader and Dispenser system, or MCRD allows a player to store their race results, points accumulated, vehicle information and vehicle tuning data on a "credit card" size storage device. This information can then be taken with the player to any Initial D driver in the U.S., allowing the player to continue fine tuning their car(s) in their quest to become the fastest driver!

Game Features

- 4 Challenging Courses
- 16 Driving Variations – Day/Night or Clockwise/Counter-Clockwise
- 6 Major Auto Manufacturers with more than 20 vehicles.
- 27 Automobile Parts Suppliers for Tuning players vehicle.
- MCRD allows storage of player information on a credit-card sized device.
- Adrenaline Pumping Euro-beat Soundtrack.

Available – Early October

Configuration – 29" Twin cabinet – 2 seats



Soul Surfer

Making a game like Soul Surfer wasn't easy. The R&D team, Sega Rosso, knew very little about surfing. They thought it'd be a good idea to visit the places where surfing is popular. So they set off to places like Hawaii, Australia, Polynesia, Europe, South Africa and California! Once there they hung out on the beaches, visited with local surfers and tried their hands at surfing! Tough Job Huh! That's what it takes to make a World Class Video Game Simulator with a Motion-based platform.



Game Objective

Soul Surfer features two stages (Easy & Hard), each with four magnificently detailed shorelines of beaches from around the world. Four different surfers offer a variety of over 30 mind-boggling surfboard tricks. Valuable coin and time-bonus power-ups add depth to an already deep playing game. An improved and very reliable surfboard platform moves flawlessly to execute tricks.

Soul Surfer also offers an Internet Ranking System. Players are given a password at the end of each game containing their scoring information. By visiting www.S-Surfer.com, players can register their score and see where they rank in the WORLD! Players can also find out where Soul Surfer games are located. Operators or Players should simply enter the location where the game is located on this site, and it let would-be surfers know here to go.

Play Sega's new Surf Board simulator, "Soul Surfer", and you will know what the Beach Boys have been singing about all these years!

Game Features

- 31khz 50" Monitor and Motion-Based platform
- 2 Surfing Stages – Easy & Hard
- 7 Challenging Oceans
- 4 Different Surfers to chose from
- Popular Surf Company Licenses
- Internet Ranking and Game Locator

Availability – NOW

Configuration – 1 Player 50" Deluxe



MCRD Technology

What is it?

MCRD might just be the single most important technological advancement introduced to the coin-op industry in the past five years. Sega's exclusive **Memory Card Reader and Dispenser** device expands the coin-op game playing experience in ways no other technology can touch. MCRD was first introduced in Japan on Derby Owners Club over two years ago. It's the single biggest reason DOC became the worldwide phenomenon it is today.

What does it do?

MCRD lets players personalize their game play experience. Each game equipped with MCRD lets players customize their character in a unique and personal way. It also lets them take their accumulated game data with them when they finish playing one day, and start where they left off the next. It literally connects the player to the game. They feel a sense of ownership by taking a piece of the game home with them.

How does it work?

Games equipped with MCRD come with a card dispenser/printer attached. Cards are the size of a credit card but quite a bit thinner. Player information is recorded on the card by thermal, not magnetic imprint. That's why you don't see a magnetic strip on the back of an MCRD card. The card is a constant, physical reminder of a player's connection to the game.

How many games have it?

To date, Sega has released three titles utilizing MCRD, Derby Owners Club, Club Kart, and Initial D. In Japan, a great deal of thought and planning went into the release order. The design staffs at Sega envisioned players learning about how to manipulate and use MCRD in a sequence similar to how they likely learned how to get around without having to walk. This sequence was,

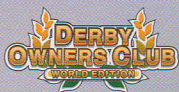

DOC. Why? Many people rode a horse before they ever got behind the wheel of a car. Bet you know someone who rode before they drove.



Club Kart. Most people probably visited a fair, carnival, or tourist area and were thrilled to drive a go-kart long before they were licensed to drive a car. Didn't you?



Initial-D. Raise your hand if, after buying your first car, the first job you got was delivering pizzas. Initial-D is based on a tremendously popular Japanese cartoon and comic book about — you guessed it — a teenage delivery boy.

In America we literally put the "Kart" before the horse. Club Kart was the first game released in the US that utilized MCRD followed by DOC. This was due to the complexities involved with translating DOC from Japanese to English thereby delaying its US release.

Why should you care?

There are Derby Owners Club games on location in America right now earning over \$12,000 per week. We have Initial Ds on test earning \$150-\$200 per seat, per day. Could you use that kind of income on your route or in your locations?

There are DOC players with over 200 DOC Club Cards. That represents an investment of over \$5,000 in less than a year on one game. How many individual players do you have putting that much into one of your video games?

MCRD works.

MCRD builds player loyalty. It results in players visiting your locations more often, staying longer, and, most importantly, spending more money while they're there. Isn't that exactly what you've been searching for?

It's a whole new world for coin-op, and Sega's leading the way. Don't get passed by.

To find out more about MCRD, visit your authorized Sega distributor.

SEGA®



DOC: Original game © SEGA © Hitmaker/SEGA, 2001
Initial D: © Shuichi Shigeno/KODANSHA All rights reserved
Manufactured and produced by SEGA ROSSO/SEGA under license from Kodansha, LTD
ClubKart: © SEGA Corporation 2000

Sega Feature Chart

	Virtua Fighter 4 Evolution	Initial D	Virtua Striker 2002	Soul Surfer	Crazy Taxi High Roller	Derby Owners Cub	Walk the Dog	House of the Dead 3	Sonic & Tails Spinner	Crazy Taxi Roll-down
50" Monitor	No	No	No	Yes	No	Yes, two	Yes	Yes	N/A	N/A
29" Monitor	No	Yes	No	No	Yes	No	No	Yes	N/A	N/A
19" monitor	No	No	No	No	No	Yes, eight	No	No	N/A	N/A
Conversion Kit	Yes	No	Yes	No	No	No	No	No	N/A	N/A
Number of Players	2	2	2	1	1	8	1	2	1	2
Linking up to	n/a	2	n/a	n/a	n/a	n/a	n/a	n/a	n/a	n/a
Buy-in Feature	Yes	Yes	Yes	Yes	Yes	n/a	Yes	Yes	n/a	n/a
AAMA Rating	yellow	green	green	green	green	green	green	red	green	green
Availability	September, 2002	October, 2002	October, 2002	Now	TBA	Now	TBA	November, 2002	October, 2002	TBA



Sega Enterprises, Inc. (USA)
 650 Townsend St., Suite 575
 San Francisco, CA 94103
 phone 415-701-6500 • fax 415-701-6568
www.segaarcade.com