

TAITO[®]



TAITO F3 PACKAGE SYSTEM[™]

INSTRUCTION MANUAL

TAITO CORPORATION.

G2500766A

Notes for handling

The game PC board applies mother PC board system and consists of various fine precision electronic parts. Therefore, handle it carefully and prevent the mother board from the following:

- Do not give it any shocks by dropping it on the floor or striking it.
- Do not pour any liquid such as water on the mother PC board. Do not touch metal objects such as screws to the surface of the mother PC board.
- Do not disassemble the case of the mother PC board or modify the PC board.
- Do not use the PC board while it is sealed in a bag or a box.

The manufacturer cannot accept repair requirements of the ROM PC board in the following cases, regardless what the faulty condition is:

- a) When there is an indication that the plastic enclosure of the ROM PC board is opened.
- b) When there is an indication of peeling off or actually having peeled off the seal which was stuck on the backside of the ROM PC board.

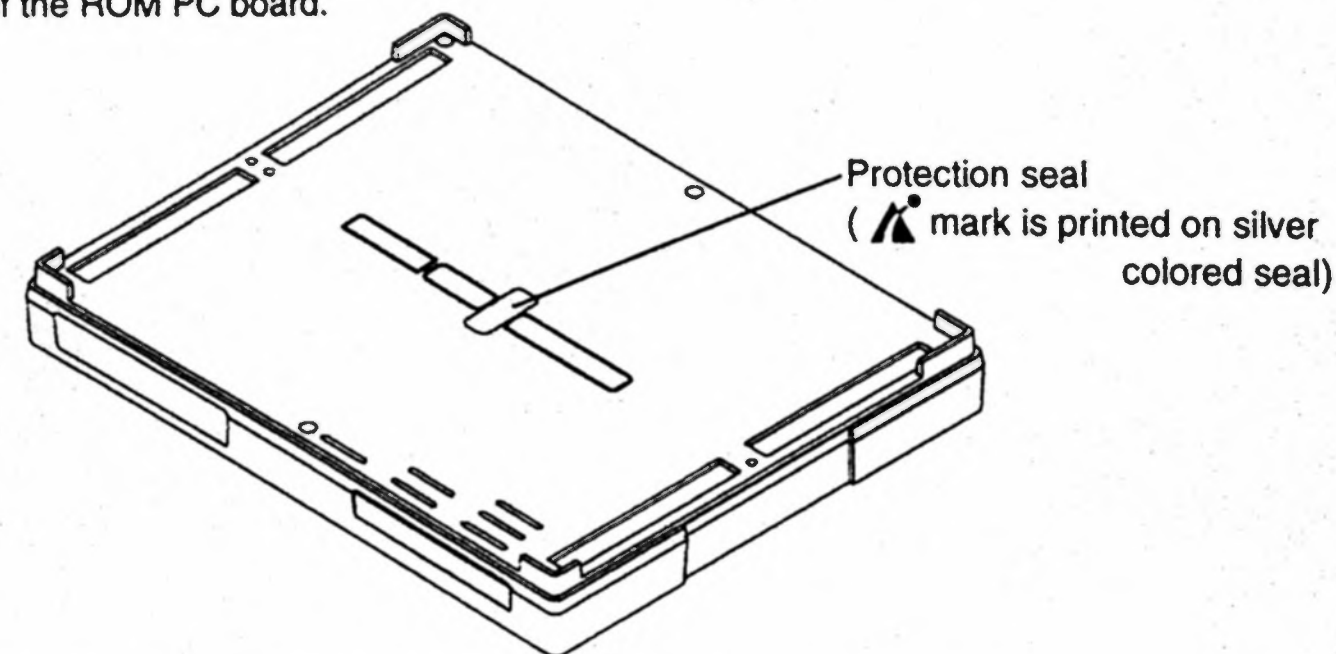

The seals on the mother PC board and the ROM PC board indicate the destination of these products. The seal of the mother PC board is located at the center of the PC board. The seal of the ROM PC board is located at the backside of the PC board. When the indication contents of the mother PC board seal and the ROM PC board is different, you cannot connect this ROM PC board with the mother PC board.

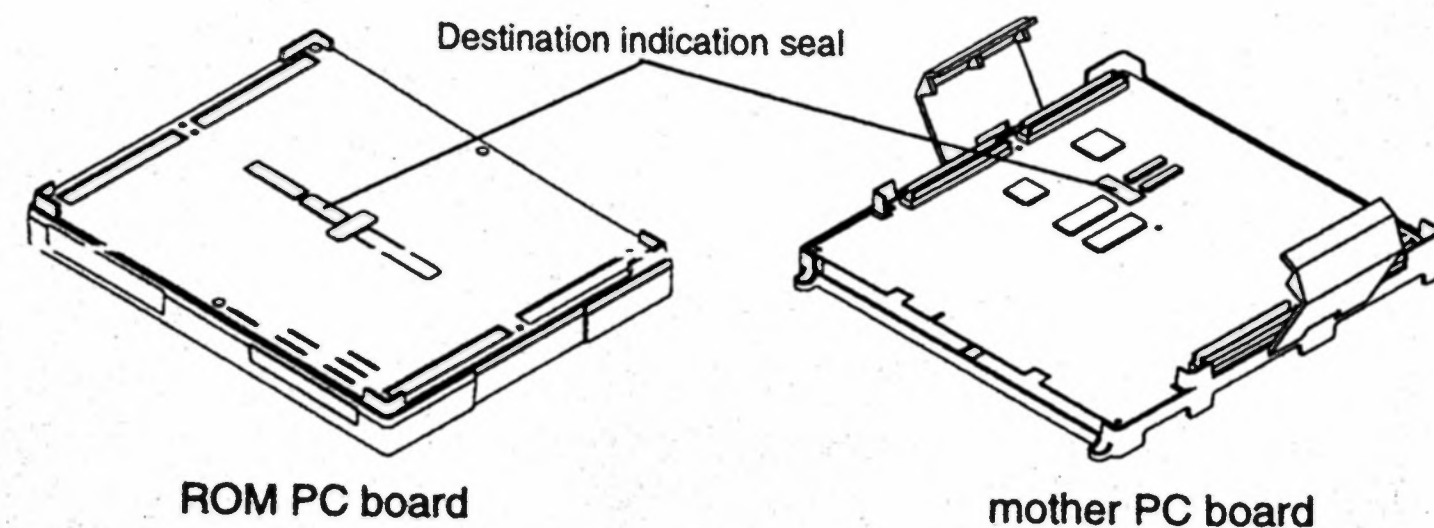

Name of each part

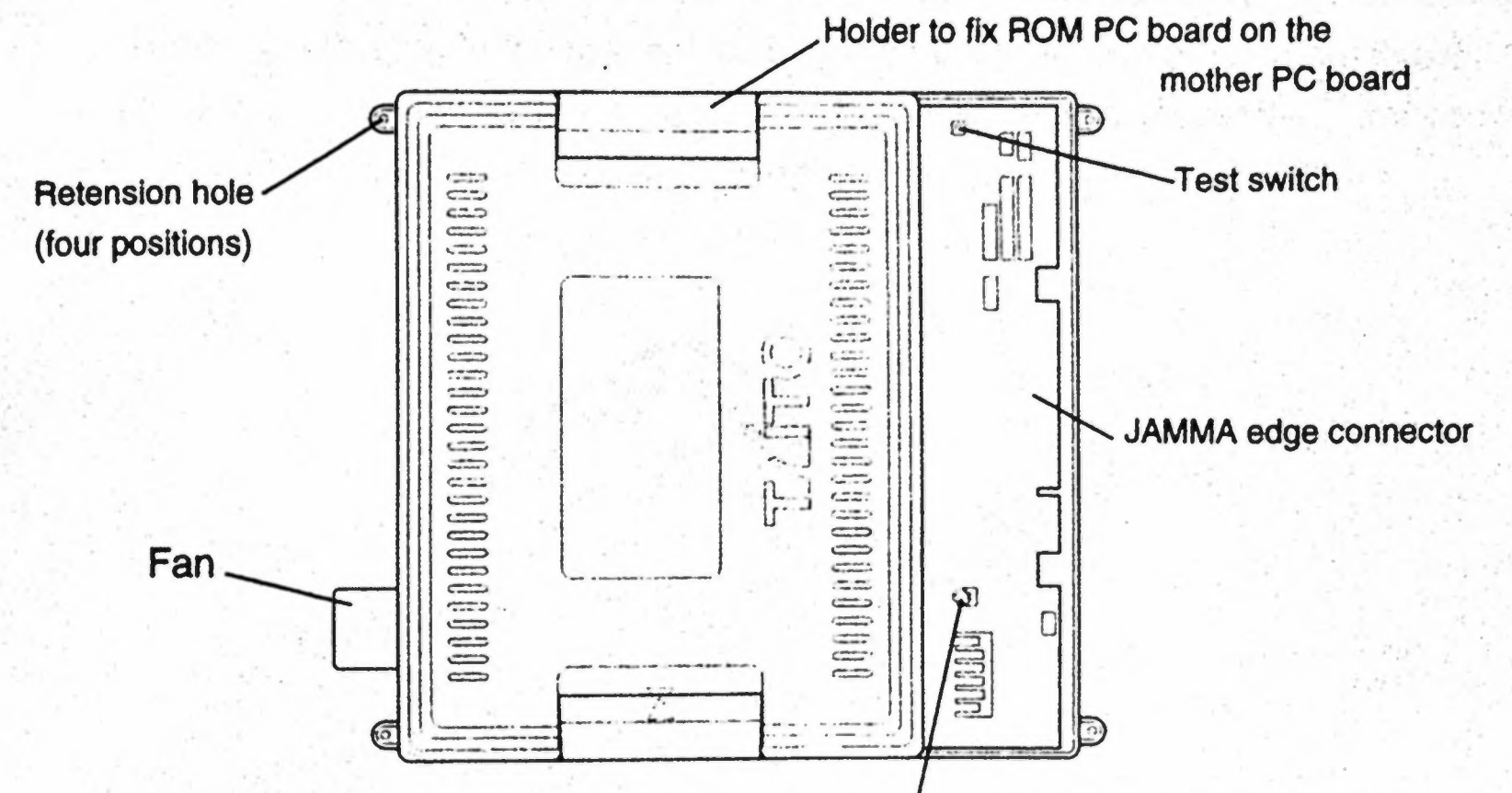

This volume is not for sound level adjustment. Do not turn this volume as it is adjusted before delivery. For adjustment of sound volume, use the test switch.

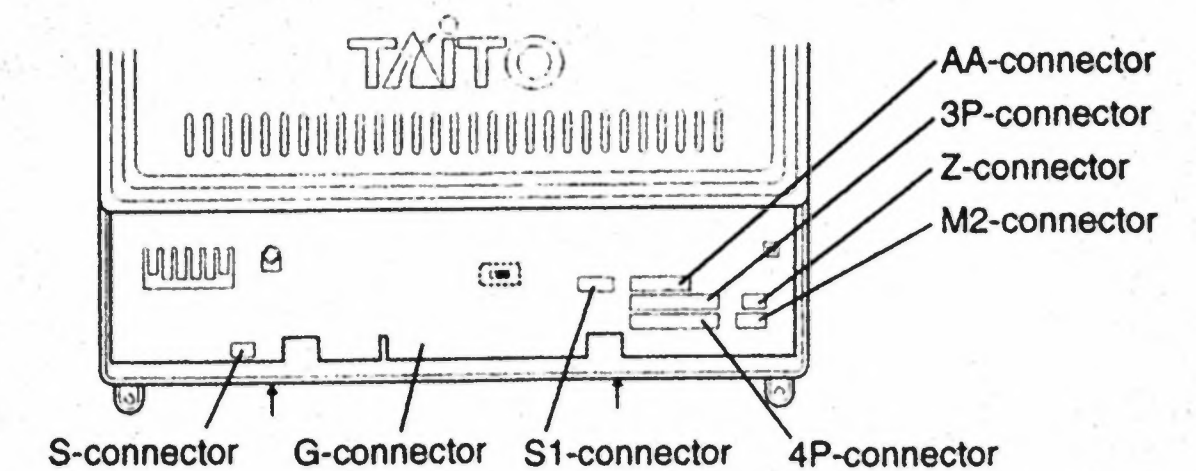
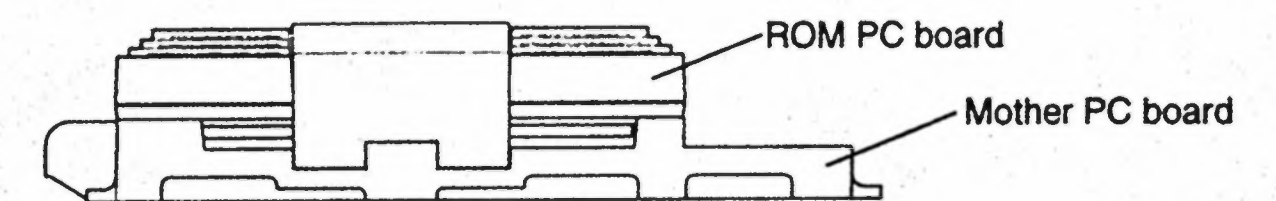

Notes

- 1) Some connectors, except the G-connector, may not be used for some specific games.
- 2) When connecting the G-connector, do not grip the black plastic part shown by the arrow(↑) above as this part may be damaged.
- 3) Connectors shown by dotted lines vary in insertion positions with each type of games.(See the instruction manual of the ROM PC board.)

Connection of the mother PC board and ROM PC board

- (1) Match both triangle marks (shown below) of the mother PC board and ROM PC board. Then insert the connector.

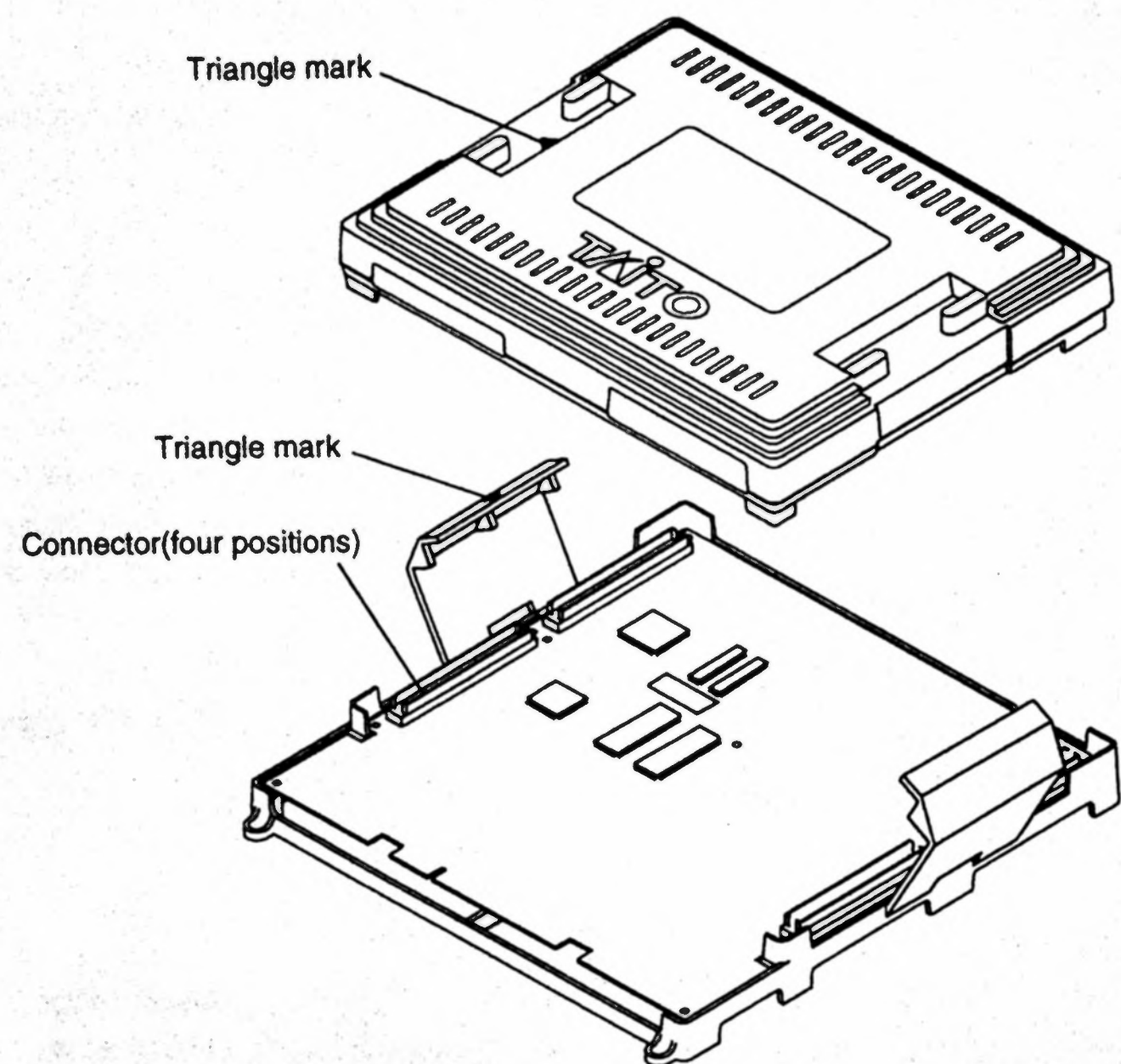

- (2) Set the ROM PC board on the mother PC board so that there is no gap at the four corners. (→)

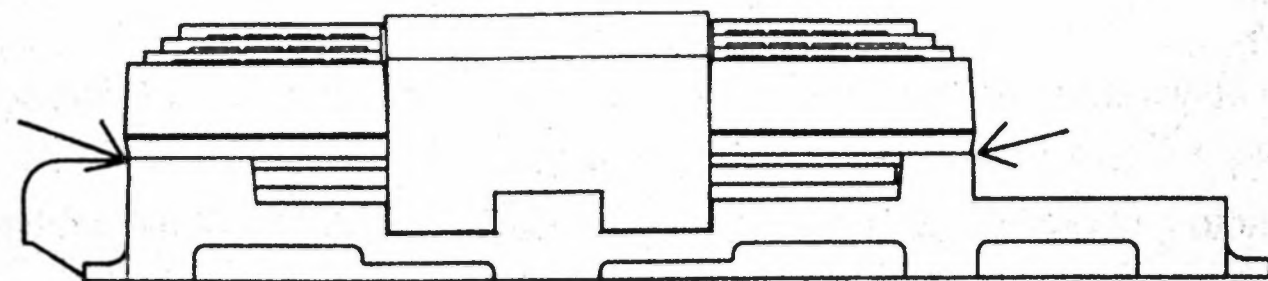

- (3) Lock the two fixing holders of the mother PC board on the ROM PC board. Each fixing holder has two tiny claws to lock onto the ROM PC board. Confirm that these claws are appropriately locked by hearing a "click" sound.

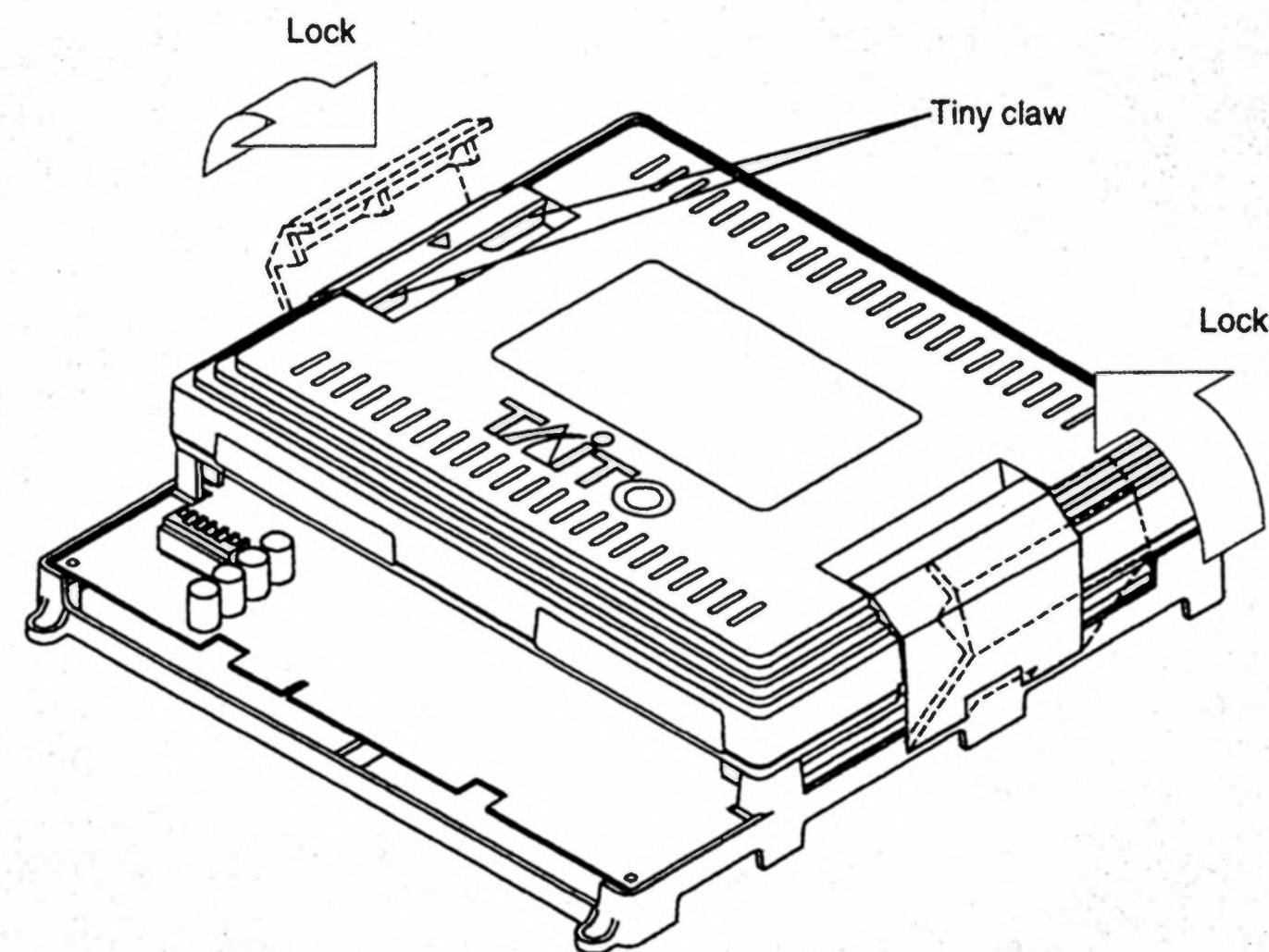

- (4) When taking of the ROM PC board from the mother PC board, follow the reverse procedure of item (1) to (3) above. However, when removing the fixing holders which are locking onto the ROM PC board, take out the claws one by one to release locking. Then follow the procedure of item (1) to (3) above.